

### PACKAGE DIMENSIONS

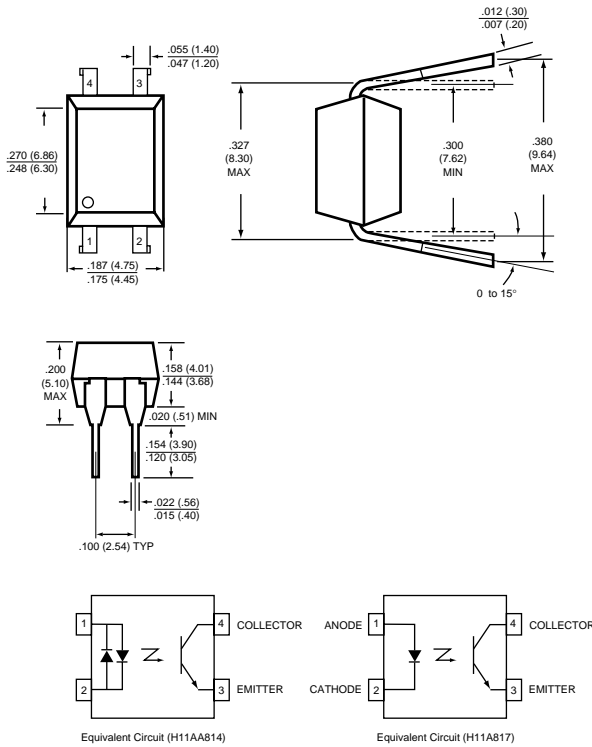

NOTE: ALL DIMENSIONS ARE IN INCHES (mm)  
PACKAGE CODE T

### DESCRIPTION

The QT Optoelectronics H11AA814 Series consists of two gallium arsenide infrared emitting diodes, connected in inverse parallel, driving a single silicon phototransistor in a 4-pin dual in-line package.

The H11A817 Series consists of a gallium arsenide infrared emitting diode driving a silicon phototransistor in a 4-pin dual in-line package.

### FEATURES

- Compact 4-pin package
- Current transfer ratio in selected groups:
 

H11AA814:	20-300%	H11A817:	50-600%
H11AA814A:	50-150%	H11A817A:	80-160%
		H11A817B:	130-260%
		H11A817C:	200-400%
		H11A817D:	300-600%

### APPLICATIONS

- H11AA814 Series**
- AC line monitor
  - Unknown polarity DC sensor
  - Telephone line interface
- H11A817 Series**
- Power supply regulators
  - Digital logic inputs
  - Microprocessor inputs
  - Industrial controls

### ABSOLUTE MAXIMUM RATING

#### TOTAL PACKAGE

Storage temperature . . . . . -55° to 150° C  
 Operating temperature . . . . . -55° to 100° C  
 Lead solder temperature . . . . . 260° C for 10 sec  
 Power dissipation . . . . . 200 mW

#### INPUT DIODE

Power dissipation (25° C ambient) . . . . . 70 mW  
 Derate linearly (above 25° C) . . . . . 1.33 mW/° C  
 Continuous forward current . . . . . 50 mA  
 Peak forward current (1 μs pulse, 300 pps) . . . . . 1 A  
 Reverse voltage (H11A817) . . . . . 5 V

#### OUTPUT TRANSISTOR

Power dissipation (25° C ambient) . . . . . 150 mW  
 Derate linearly (above 25° C) . . . . . 2.0 mW/° C  
 $V_{CEO}$  . . . . . 35 V  
 $V_{ECO}$  . . . . . 6 V  
 Continuous collector current . . . . . 50 mA

## ELECTRO-OPTICAL CHARACTERISTICS ( $T_A = 25^\circ\text{C}$ Unless otherwise specified)

### INDIVIDUAL COMPONENT CHARACTERISTICS (Applies to all unless indicated otherwise)

PARAMETER	SYMBOL	MIN	TYP	MAX	UNITS	TEST CONDITIONS
INPUT DIODE						
Forward voltage						
H11A817	$V_F$		1.2	1.5	V	$I_F = 20\text{ mA}$
H11AA814	$V_F$		1.2	1.5	V	$I_F = \pm 20\text{ mA}$
Reverse current						
H11A817	$I_R$		.001	10	$\mu\text{A}$	$V_R = 5\text{ V}$
OUTPUT TRANSISTOR						
Breakdown voltage						
Collector to emitter	$BV_{CEO}$	35	100		V	$I_C = 1\text{ mA}, I_F = 0$
Emitter to collector	$BV_{ECO}$	6	10		V	$I_E = 100\ \mu\text{A}, I_F = 0$
Collector dark current	$I_{CEO}$		.025	100	nA	$V_{CE} = 10\text{ V}, I_F = 0$
Capacitance	$C_{CE}$		8		pF	$V_{CE} = 0\text{ V}, f = 1\text{ MHz}$

### TRANSFER CHARACTERISTICS

CHARACTERISTIC	SYMBOL	MIN	TYP	MAX	UNITS	TEST CONDITIONS
DC current transfer ratio						
H11AA814	CTR	20		300	%	$I_F = \pm 1\text{ mA}, V_{CE} = 5\text{ V}$
H11AA814A	CTR	50		150	%	$I_F = \pm 1\text{ mA}, V_{CE} = 5\text{ V}$
H11A817	CTR	50		600	%	$I_F = 5\text{ mA}, V_{CE} = 5\text{ V}$
H11A817A	CTR	80		160	%	
H11A817B	CTR	130		260	%	
H11A817C	CTR	200		400	%	
H11A817D	CTR	300		600	%	
Saturation Voltage	$V_{CE(SAT)}$		0.1	0.2	V	$I_F = (\pm)20\text{ mA}, I_C = 1\text{ mA}$
Rise time (non saturated)	$t_r$		2.4	18	$\mu\text{s}$	$I_C = 2\text{ mA}, V_{CE} = 2\text{ V}, R_L = 100\ \Omega$
Fall time (non saturated)	$t_f$		2.4	18	$\mu\text{s}$	$I_C = 2\text{ mA}, V_{CE} = 2\text{ V}, R_L = 100\ \Omega$

### ISOLATION CHARACTERISTICS

CHARACTERISTIC	SYMBOL	MIN	TYP	MAX	UNITS	TEST CONDITIONS
Steady-state isolation voltage	$V_{ISO}$	5300			$V_{RMS}$	1 Minute
Isolation resistance	$R_{ISO}$	$10^{11}$			$\Omega$	$V_{I-O} = 500\text{ VDC}$
Isolation capacitance	$C_{ISO}$		0.5		pF	$V_{I-O} = \emptyset, f = 1\text{ MHz}$

TYPICAL CHARACTERISTICS

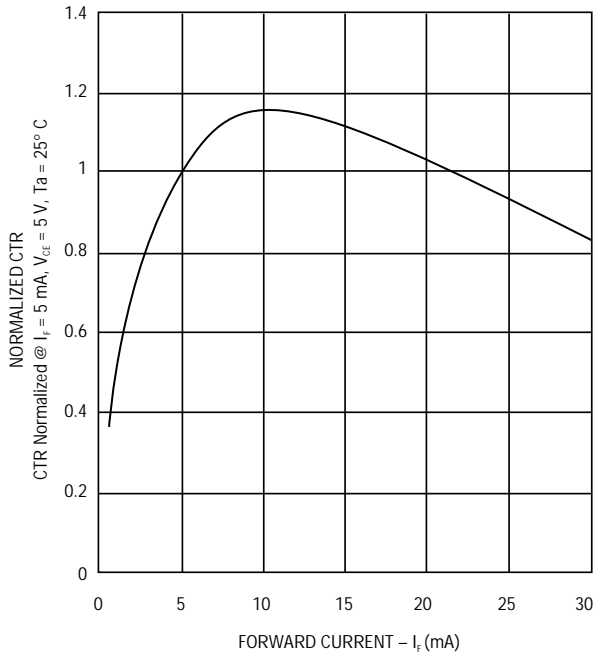

FIG. 1 - Normalized CTR vs. Forward Current

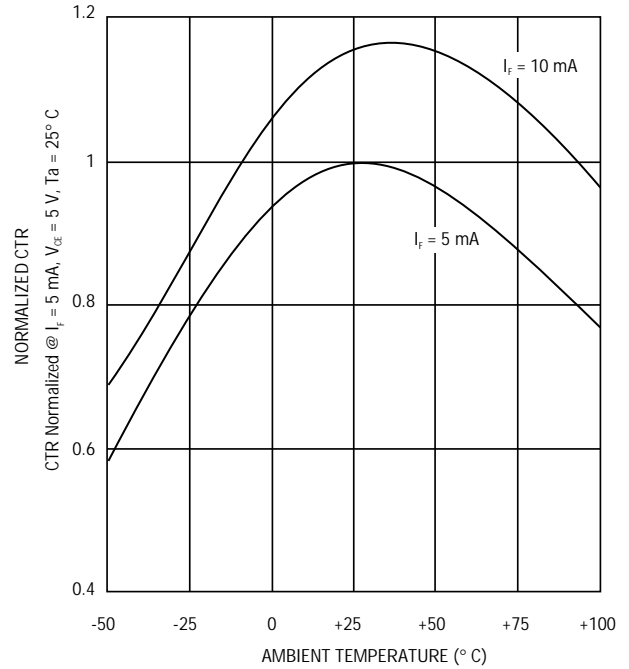

FIG. 2 - Normalized CTR vs. Ambient Temperature

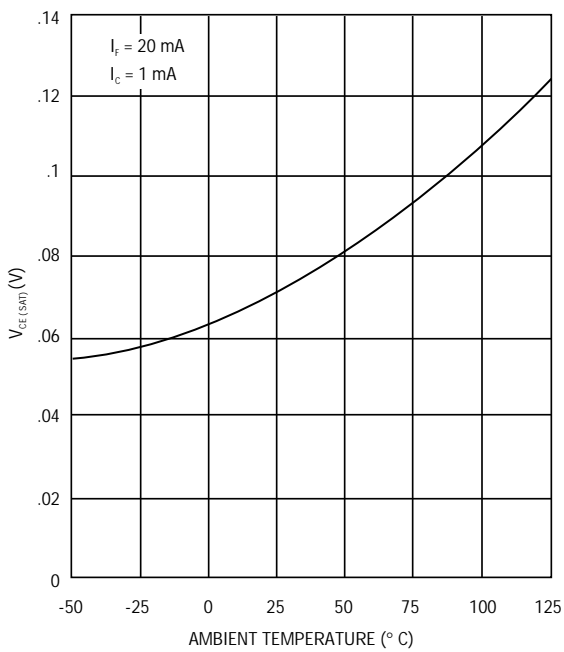

FIG. 3 -  $V_{CE(SAT)}$  vs. Ambient Temperature

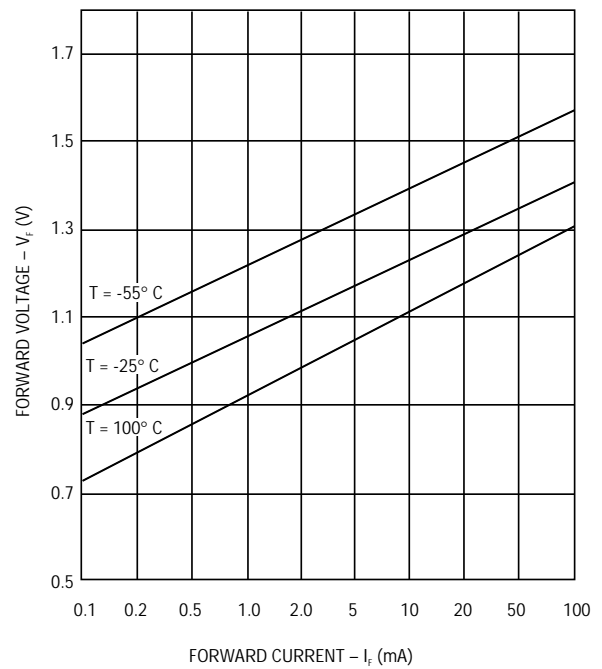

FIG. 4 - Forward Voltage vs. Forward Current

TYPICAL CHARACTERISTICS

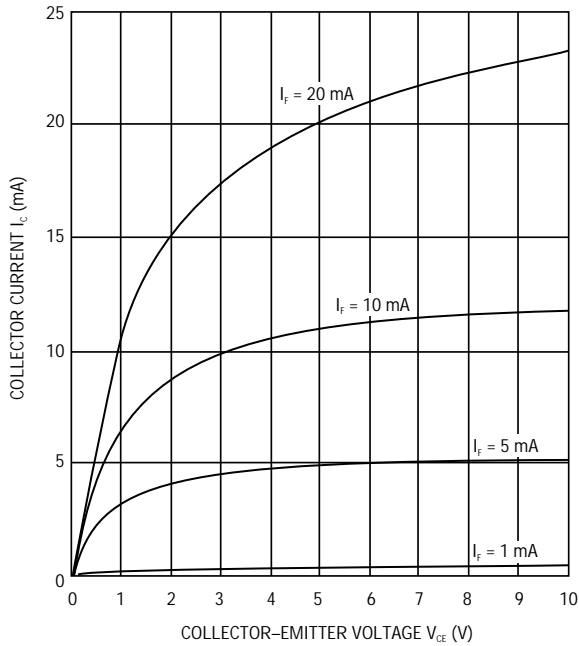

FIG. 5 - Collector Current vs. Collector-Emitter Voltage

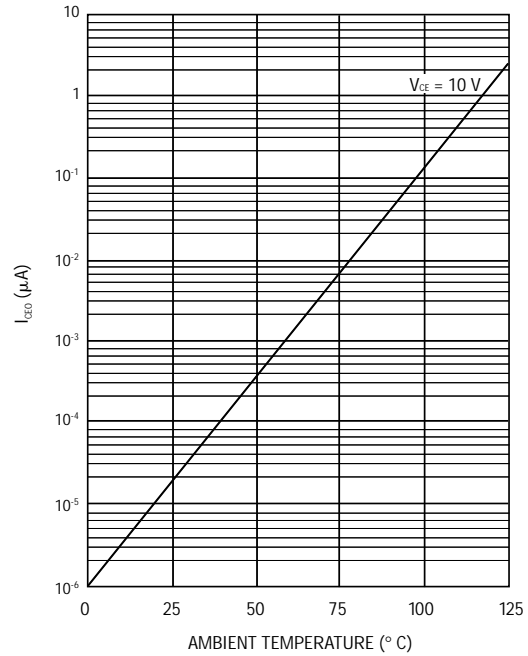

FIG. 6 - Collector Leakage Current vs. Ambient Temperature

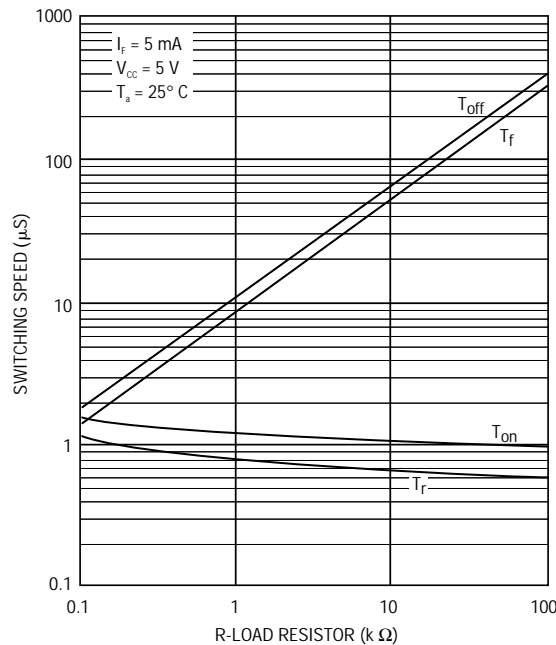

FIG. 7 - Switching Speed vs. Load Resistor (TYP)

Call QT Optoelectronics for more information or the phone number of your nearest distributor.

United States 800-533-6786 ■ France 33 01/43.99.25.12 ■ Germany 49 089/96.30.51 ■ United Kingdom 44 [0] 1296/39.44.99 ■ Asia/Pacific 603/735-2417