

SINGLE-CHANNEL
6N137
HCPL-2601
HCPL-2611

DUAL-CHANNEL
HCPL-2630
HCPL-2631

DESCRIPTION

The 6N137, HCPL-2601/2611 single-channel and HCPL-2630/2631 dual-channel optocouplers consist of a 850 nm AlGaAs LED, optically coupled to a very high speed integrated photodetector logic gate with a strobable output. This output features an open collector, thereby permitting wired OR outputs. The coupled parameters are guaranteed over the temperature range of -40°C to +85°C. A maximum input signal of 5 mA will provide a minimum output sink current of 13 mA (fan out of 8).

An internal noise shield provides superior common mode rejection of typically 10 kV/μs. The HCPL-2601 and HCPL-2631 has a minimum CMR of 5 kV/μs. The HCPL-2611 has a minimum CMR of 10 kV/μs.

FEATURES

- Very high speed-10 MBit/s
- Superior CMR-10 kV/μs
- Double working voltage-480V
- Fan-out of 8 over -40°C to +85°C
- Logic gate output
- Storable output
- Wired OR-open collector
- U.L. recognized (File # E90700)

APPLICATIONS

- Ground loop elimination
- LSTTL to TTL, LSTTL or 5-volt CMOS
- Line receiver, data transmission
- Data multiplexing
- Switching power supplies
- Pulse transformer replacement
- Computer-peripheral interface

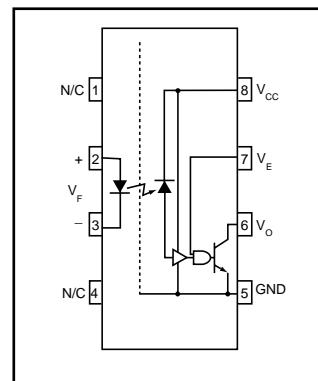
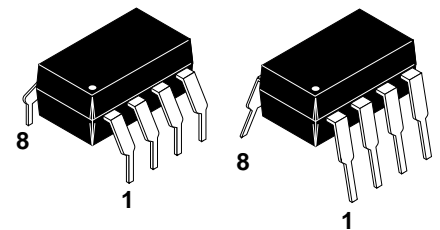
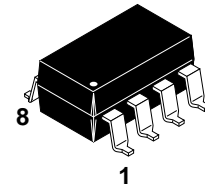

Single-channel
circuit drawing

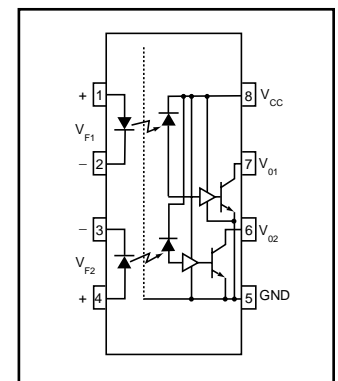

Dual-channel
circuit drawing

TRUTH TABLE (Positive Logic)

Input	Enable	Output
H	H	L
L	H	H
H	L	H
L	L	H
H	NC	L
L	NC	H

A 0.1 μF bypass capacitor must be connected between pins 8 and 5.
(See note 1)



HIGH SPEED-10 MBit/s LOGIC GATE OPTOCOUPLERS

SINGLE-CHANNEL
6N137
HCPL-2601
HCPL-2611

DUAL-CHANNEL
HCPL-2630
HCPL-2631

ABSOLUTE MAXIMUM RATINGS (No derating required up to 85°C)

Parameter	Symbol	Value	Units
Storage Temperature	T_{STG}	-55 to +125	°C
Operating Temperature	T_{OPR}	-40 to +85	°C
Lead Solder Temperature	T_{SOL}	260 for 10 sec	°C
EMITTER			
DC/Average Forward Current	I_F	50	mA
Input Current		30	
Enable Input Voltage	V_E	5.5	V
Not to exceed V_{CC} by more than 500 mV			
Reverse Input Voltage	V_R	5.0	V
Power Dissipation	P_I	100	mW
		45	
DETECTOR			
Supply Voltage	V_{CC} (1 minute max)	7.0	V
Output Current	I_O	50	mA
		50	
Output Voltage	V_O	7.0	V
Collector Output Power Dissipation	P_O	85	mW
		60	

RECOMMENDED OPERATING CONDITIONS

Parameter	Symbol	Min	Max	Units
Input Current, Low Level	I_{FL}	0	250	μA
Input Current, High Level	I_{FH}	*6.3	15	mA
Supply Voltage, Output	V_{CC}	4.5	5.5	V
Enable Voltage, Low Level	V_{EL}	0	0.8	V
Enable Voltage, High Level	V_{EH}	2.0	V_{CC}	V
Low Level Supply Current	T_A	-40	+85	°C
Fan Out (TTL load)	N		8	

* 6.3 mA is a guard banded value which allows for at least 20 % CTR degradation. Initial input current threshold value is 5.0 mA or less

SINGLE-CHANNEL
6N137
HCPL-2601
HCPL-2611

DUAL-CHANNEL
HCPL-2630
HCPL-2631

ELECTRICAL CHARACTERISTICS (T_A = -40°C to +85°C Unless otherwise specified.)

INDIVIDUAL COMPONENT CHARACTERISTICS

Parameter	Test Conditions	Symbol	Min	Typ**	Max	Unit
EMITTER						
Input Forward Voltage	(I _F = 10 mA) T _A = 25°C	V _F		1.4	1.8	V
Input Reverse Breakdown Voltage	(I _R = 10 μA)	B _{VR}	5.0			V
Input Capacitance	(V _F = 0, f = 1 MHz)	C _{IN}		60		pF
Input Diode Temperature Coefficient	(I _F = 10 mA)	ΔV _F /ΔT _A		-1.4		mV/°C
DETECTOR						
High Level Supply Current	Single Channel (V _{CC} = 5.5 V, I _F = 0 mA) Dual Channel (V _E = 0.5 V)	I _{CCH}		7	10	mA
Low Level Supply Current	Single Channel (V _{CC} = 5.5 V, I _F = 10 mA) Dual Channel (V _E = 0.5 V)	I _{CCL}		9	13	mA
Low Level Enable Current	(V _{CC} = 5.5 V, V _E = 0.5 V)	I _{EL}		-0.8	-1.6	mA
High Level Enable Current	(V _{CC} = 5.5 V, V _E = 2.0 V)	I _{EH}		-0.6	-1.6	mA
High Level Enable Voltage	(V _{CC} = 5.5 V, I _F = 10 mA)	V _{EH}	2.0			V
Low Level Enable Voltage	(V _{CC} = 5.5 V, I _F = 10 mA) (Note 3)	V _{EL}			0.8	V

SWITCHING CHARACTERISTICS (T_A = -40°C to +85°C, V_{CC} = 5 V, I_F = 7.5 mA Unless otherwise specified.)

AC Characteristics	Test Conditions	Symbol	Min	Typ**	Max	Unit
Propagation Delay Time to Output High Level	(Note 4) (T _A = 25°C) (R _L = 350 Ω, C _L = 15 pF) (Fig. 12)	T _{PLH}	20	45	75	ns
Propagation Delay Time to Output Low Level	(Note 5) (T _A = 25°C) (R _L = 350 Ω, C _L = 15 pF) (Fig. 12)	T _{PHL}	25	45	75	ns
Pulse Width Distortion	(R _L = 350 Ω, C _L = 15 pF) (Fig. 12)	T _{PHL} - T _{PLH}		3	35	ns
Output Rise Time (10-90%)	(R _L = 350 Ω, C _L = 15 pF) (Note 6) (Fig. 12)	t _r		50		ns
Output Fall Time (90-10%)	(R _L = 350 Ω, C _L = 15 pF) (Note 7) (Fig. 12)	t _f		12		ns
Enable Propagation Delay Time to Output High Level	(I _F = 7.5 mA, V _{EH} = 3.5 V) (R _L = 350 Ω, C _L = 15 pF) (Note 8) (Fig. 13)	t _{ELH}		20		ns
Enable Propagation Delay Time to Output Low Level	(I _F = 7.5 mA, V _{EH} = 3.5 V) (R _L = 350 Ω, C _L = 15 pF) (Note 9) (Fig. 13)	t _{EHL}		20		ns
Common Mode Transient Immunity (at Output High Level)	(T _A = 25°C) V _{CM} = 50 V, (Peak) (I _F = 0 mA, V _{OH} (Min.) = 2.0 V)	C _{MH}				V/μs
	6N137, HCPL-2630 (R _L = 350 Ω) (Note 10)			10,000		
	HCPL-2601, HCPL-2631 (Fig. 14)		5000	10,000		
	HCPL-2611 V _{CM} = 400 V		10,000	15,000		
Common Mode Transient Immunity (at Output Low Level)	(R _L = 350 Ω) (I _F = 7.5 mA, V _{OL} (Max.) = 0.8 V) (T _A = 25°C) V _{CM} = 50 V (Peak)	C _{ML}				V/μs
	6N137, HCPL-2630			10,000		
	HCPL-2601, HCPL-2631 (Note 11) (Fig. 14)		5000	10,000		
	HCPL-2611 (T _A = 25°C) V _{CM} = 400 V		10,000	15,000		

SINGLE-CHANNEL
6N137
HCPL-2601
HCPL-2611

DUAL-CHANNEL
HCPL-2630
HCPL-2631

TRANSFER CHARACTERISTICS (T_A = -40°C to +85°C Unless otherwise specified.)

DC Characteristics	Test Conditions	Symbol	Min	Typ**	Max	Unit
High Level Output Current	(V _{CC} = 5.5 V, V _O = 5.5 V) (I _F = 250 μA, V _E = 2.0 V) (Note 2)	I _{OH}			100	μA
Low Level Output Current	(V _{CC} = 5.5 V, I _F = 5 mA) (V _E = 2.0 V, I _{CL} = 13 mA) (Note 2)	V _{OL}		.35	.06	V
Input Threshold Current	(V _{CC} = 5.5 V, V _O = 0.6 V, V _E = 2.0 V, I _{OL} = 13 mA)	I _{FT}		3	5	mA

ISOLATION CHARACTERISTICS (T_A = -40°C to +85°C Unless otherwise specified.)

Characteristics	Test Conditions	Symbol	Min	Typ**	Max	Unit
Input-Output Insulation Leakage Current	(Relative humidity = 45%) (T _A = 25°C, t = 5 s) (V _{I-O} = 3000 VDC) (Note 12)	I _{I-O}			1.0*	μA
Withstand Insulation Test Voltage	(RH < 50%, T _A = 25°C) (Note 12) (t = 1 min.)	V _{ISO}	2500			V _{RMS}
Resistance (Input to Output)	(V _{I-O} = 500 V) (Note 12)	R _{I-O}		10 ¹²		Ω
Capacitance (Input to Output)	(f = 1 MHz) (Note 12)	C _{I-O}		0.6		pF

** All typical values are at V_{CC} = 5 V, T_A = 25°C

NOTES

- The V_{CC} supply to each optoisolator must be bypassed by a 0.1μF capacitor or larger. This can be either a ceramic or solid tantalum capacitor with good high frequency characteristic and should be connected as close as possible to the package V_{CC} and GND pins of each device.
- Each channel.
- Enable Input - No pull up resistor required as the device has an internal pull up resistor.
- t_{PLH} - Propagation delay is measured from the 3.75 mA level on the HIGH to LOW transition of the input current pulse to the 1.5 V level on the LOW to HIGH transition of the output voltage pulse.
- t_{PHL} - Propagation delay is measured from the 3.75 mA level on the LOW to HIGH transition of the input current pulse to the 1.5 V level on the HIGH to LOW transition of the output voltage pulse.
- t_r - Rise time is measured from the 90% to the 10% levels on the LOW to HIGH transition of the output pulse.
- t_f - Fall time is measured from the 10% to the 90% levels on the HIGH to LOW transition of the output pulse.
- t_{ELH} - Enable input propagation delay is measured from the 1.5 V level on the HIGH to LOW transition of the input voltage pulse to the 1.5 V level on the LOW to HIGH transition of the output voltage pulse.
- t_{EHL} - Enable input propagation delay is measured from the 1.5 V level on the LOW to HIGH transition of the input voltage pulse to the 1.5 V level on the HIGH to LOW transition of the output voltage pulse.
- CM_H - The maximum tolerable rate of rise of the common mode voltage to ensure the output will remain in the high state (i.e., V_{OUT} > 2.0 V). Measured in volts per microsecond (V/μs).
- CM_L - The maximum tolerable rate of rise of the common mode voltage to ensure the output will remain in the low output state (i.e., V_{OUT} < 0.8 V). Measured in volts per microsecond (V/μs).
- Device considered a two-terminal device: Pins 1,2,3 and 4 shorted together, and Pins 5,6,7 and 8 shorted together.

SINGLE-CHANNEL
6N137
HCPL-2601
HCPL-2611

DUAL-CHANNEL
HCPL-2630
HCPL-2631

Fig.1 Low Level Output Voltage vs. Ambient Temperature

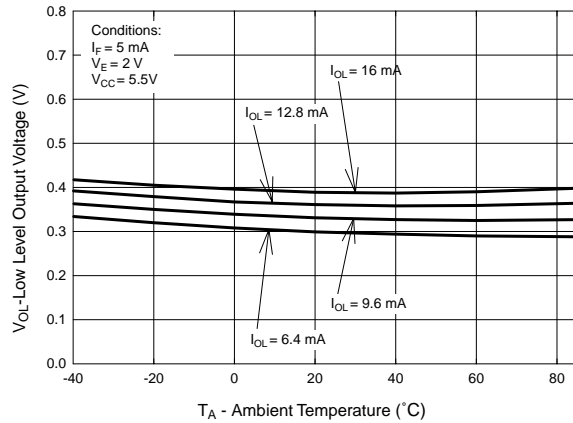

Fig. 2 Input Diode Forward Voltage vs. Forward Current

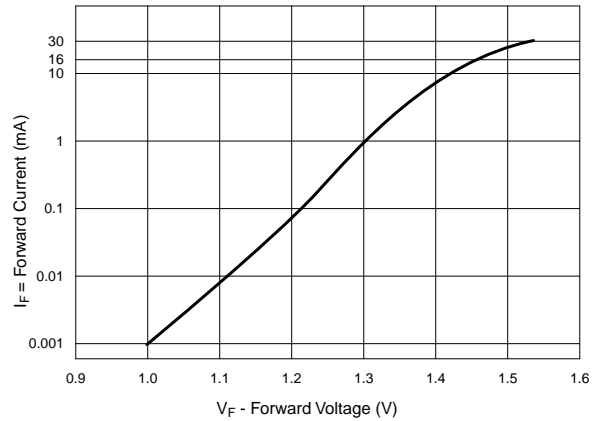

Fig.3 Switching Time vs. Forward Current

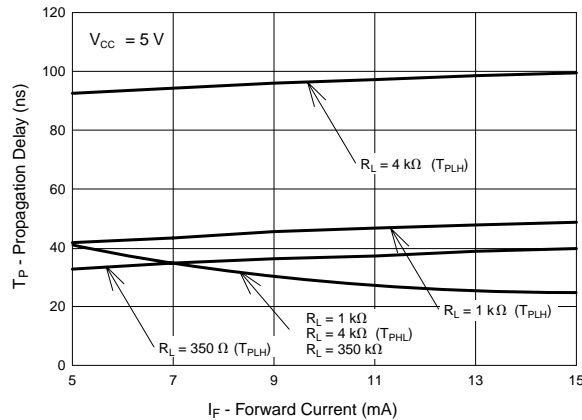

Fig. 4 Low Level Output Current vs. Ambient Temperature

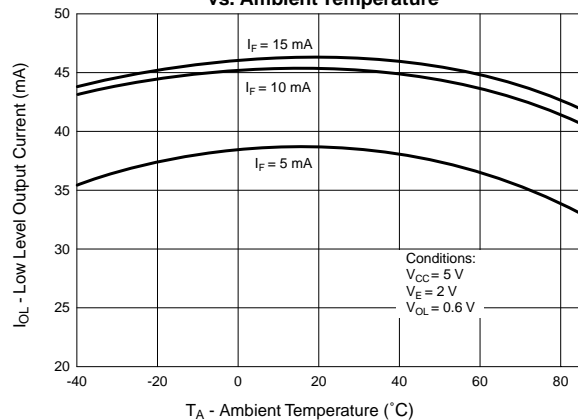

Fig. 5 Input Threshold Current vs. Ambient Temperature

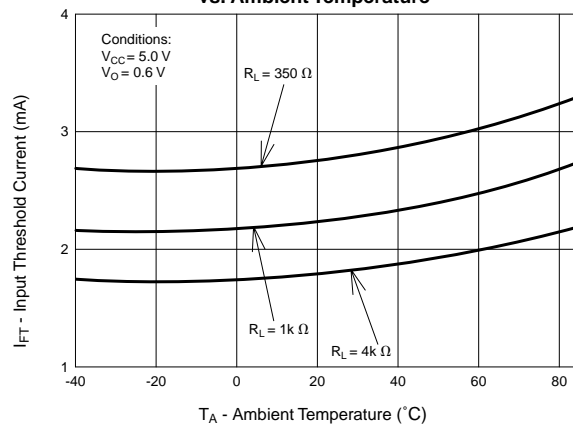
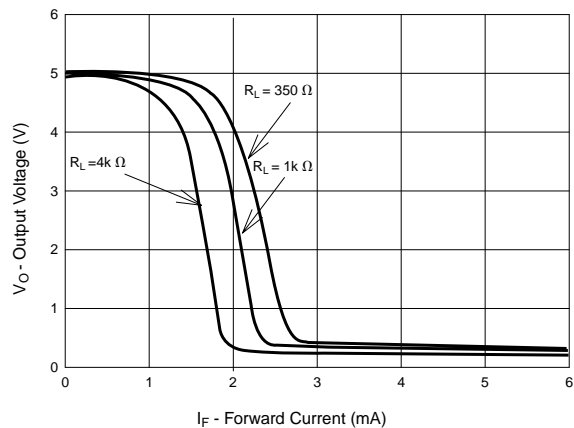

Fig. 6 Output Voltage vs. Input Forward Current



SINGLE-CHANNEL
6N137
HCPL-2601
HCPL-2611

DUAL-CHANNEL
HCPL-2630
HCPL-2631

Fig. 7 Pulse Width Distortion vs. Temperature

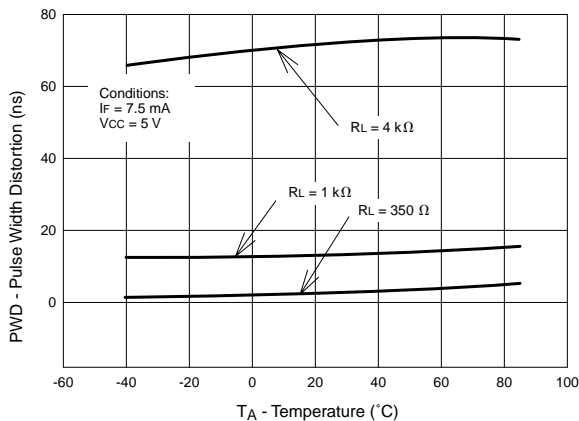

Fig. 8 Rise and Fall Time vs. Temperature

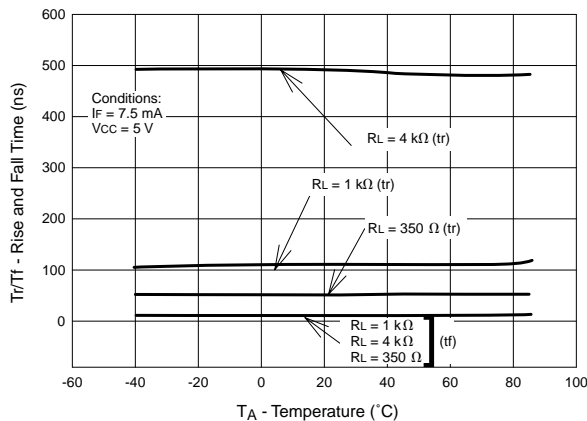

Fig. 9 Enable Propagation Delay vs. Temperature

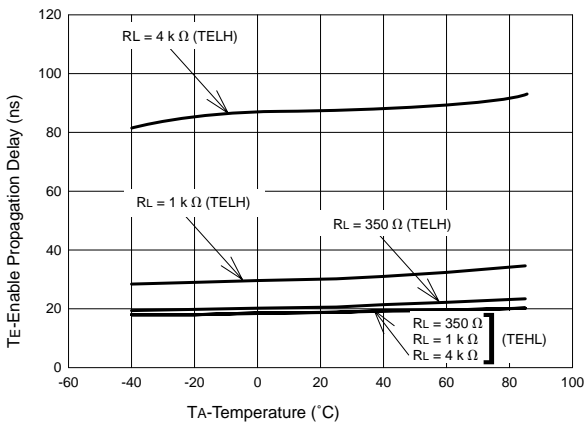

Fig. 10 Switching Time vs. Temperature

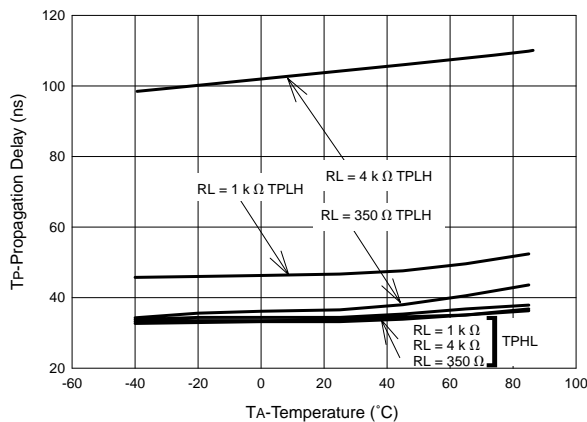
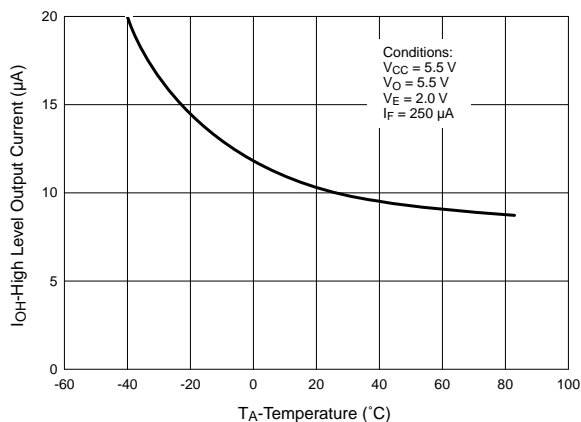

Fig. 11 High Level Output Current vs. Temperature



SINGLE-CHANNEL
6N137
HCPL-2601
HCPL-2611

DUAL-CHANNEL
HCPL-2630
HCPL-2631

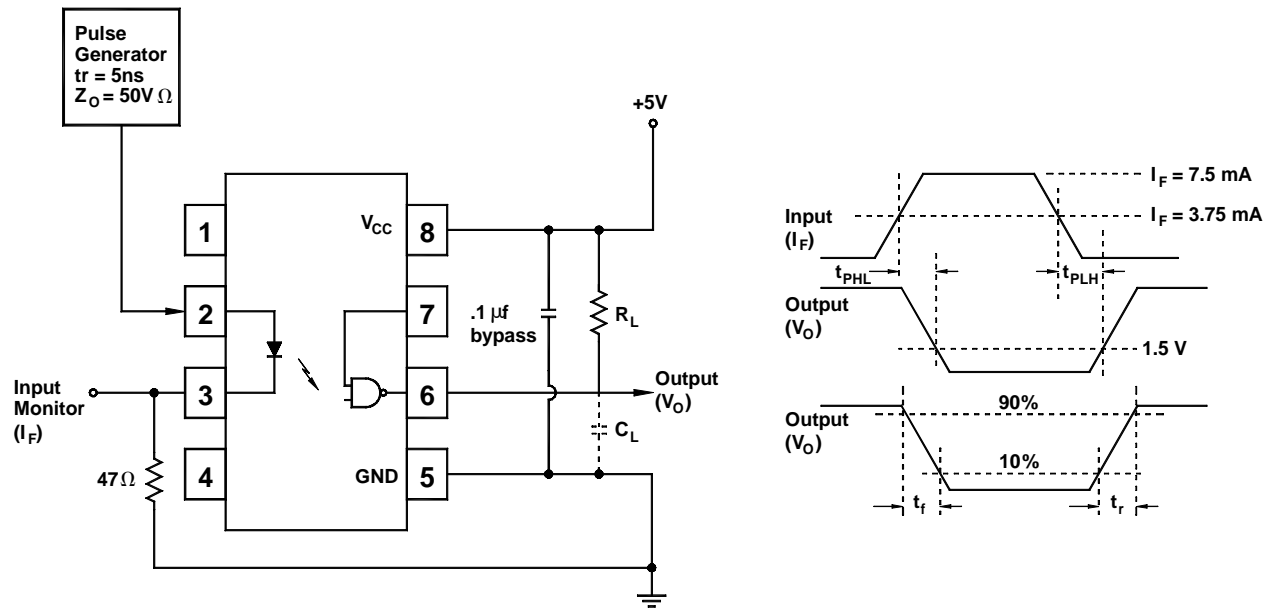

Fig. 12 Test Circuit and Waveforms for t_{PLH} , t_{PHL} , t_r and t_f .

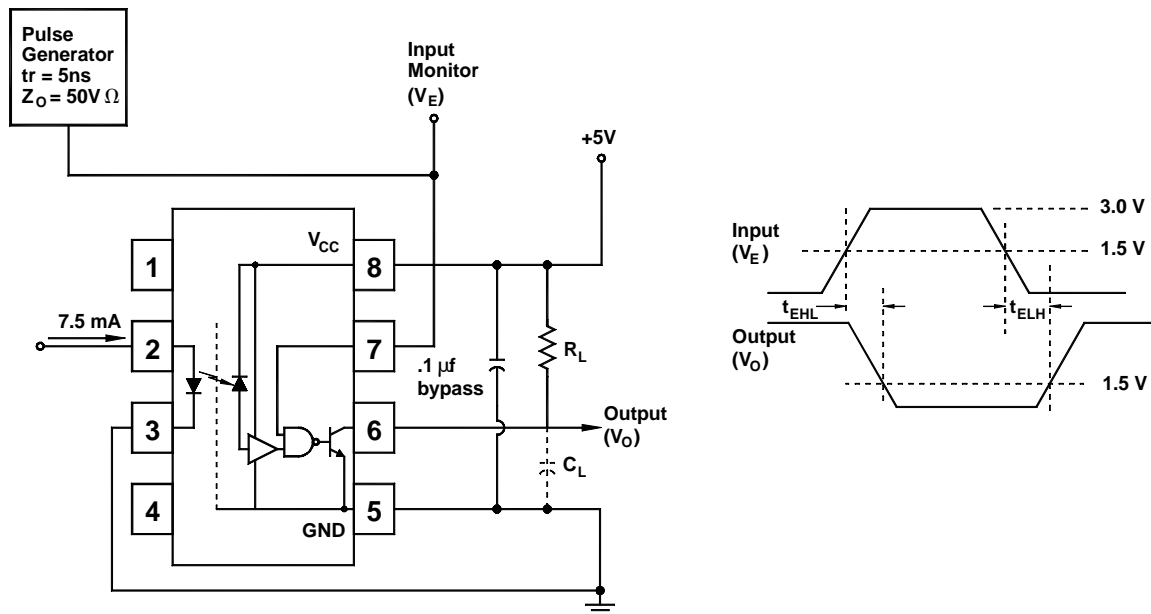

Fig. 13 Test Circuit t_{EHL} and t_{ELH} .

SINGLE-CHANNEL
6N137
HCPL-2601
HCPL-2611

DUAL-CHANNEL
HCPL-2630
HCPL-2631

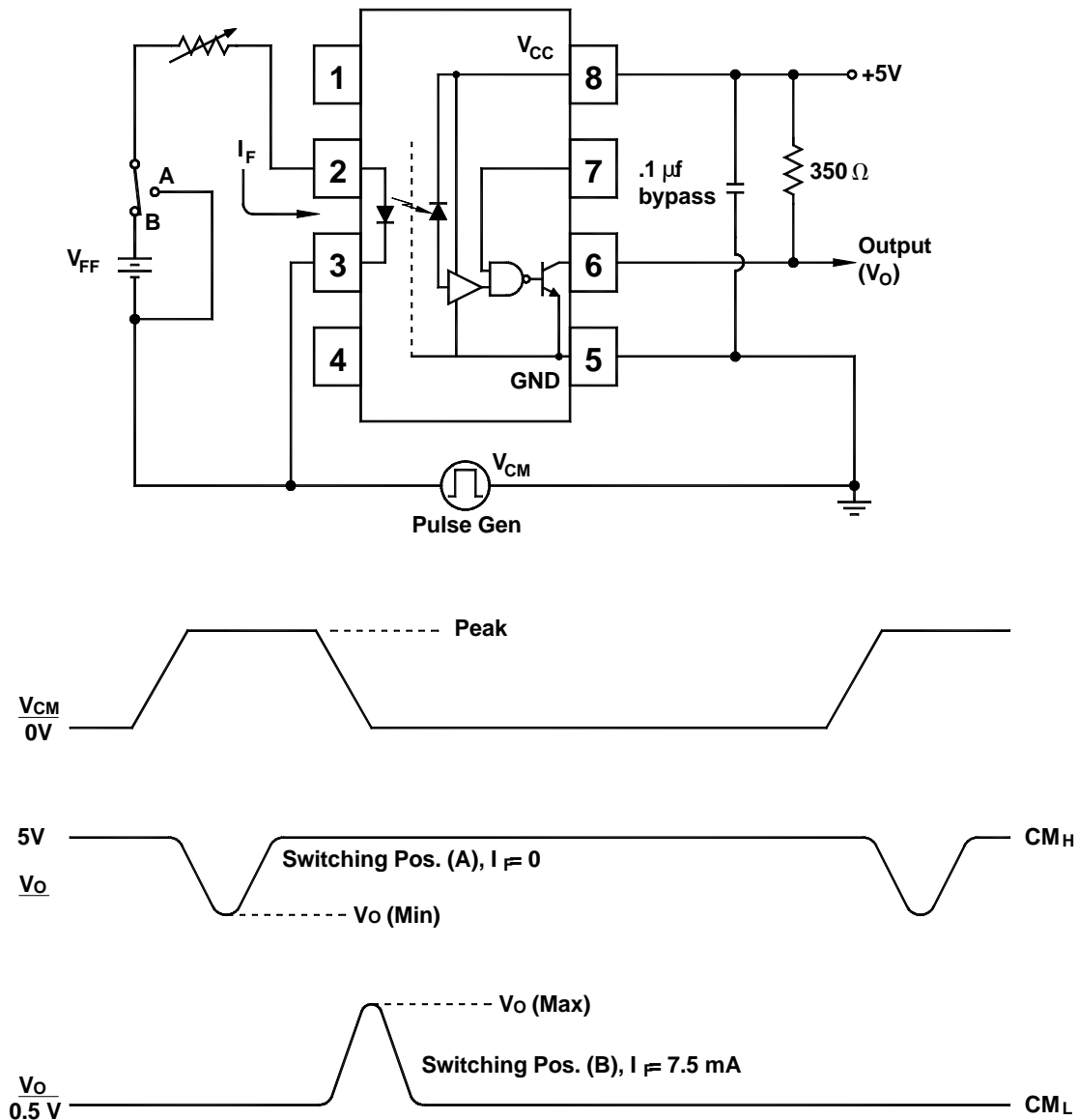
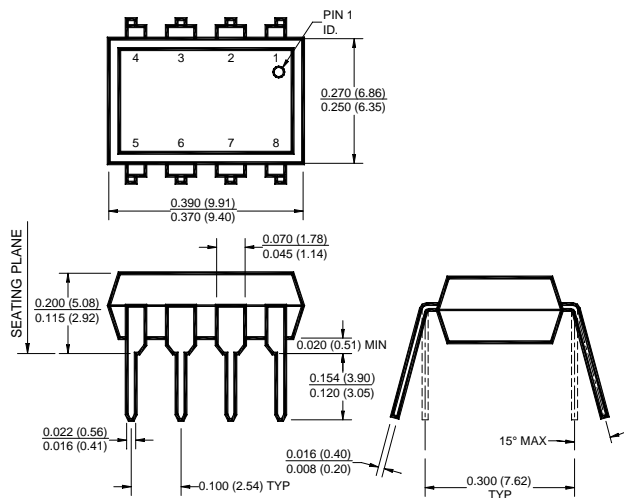

Fig. 14 Test Circuit Common Mode Transient Immunity

SINGLE-CHANNEL
6N137
HCPL-2601
HCPL-2611

DUAL-CHANNEL
HCPL-2630
HCPL-2631

Package Dimensions (Through Hole)



Package Dimensions (Surface Mount)

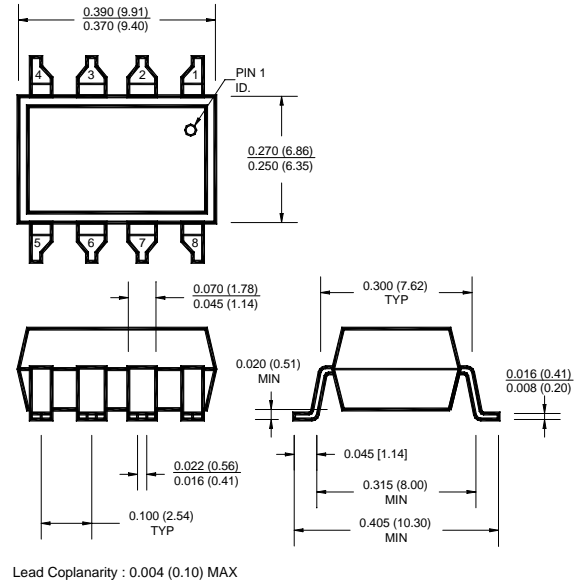

Package Dimensions (0.4" Lead Spacing)

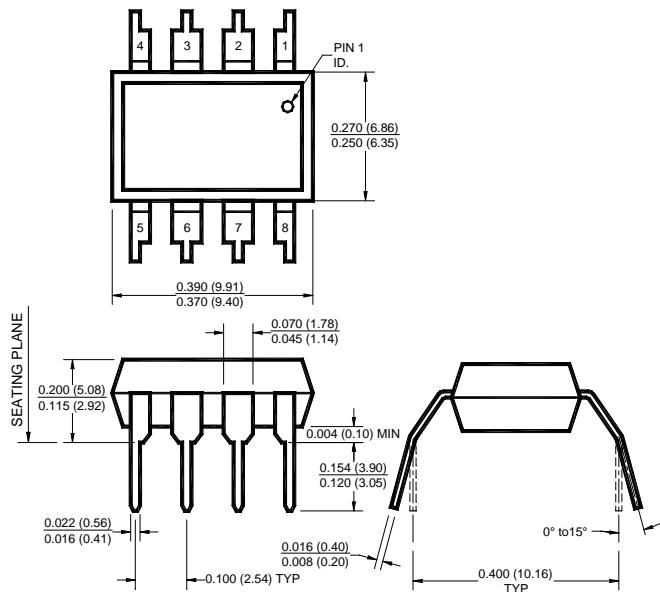

NOTE

All dimensions are in inches (millimeters)

SINGLE-CHANNEL
6N137
HCPL-2601
HCPL-2611

DUAL-CHANNEL
HCPL-2630
HCPL-2631

ORDERING INFORMATION

Option	Order Entry Identifier	Description
R2	.R2	Opto Plus Reliability Conditioning
S	.S	Surface Mount Lead Bend
SD	.SD	Surface Mount; Tape and reel
W	.W	0.4" Lead Spacing

QT Carrier Tape Specifications ("D" Taping Orientation)

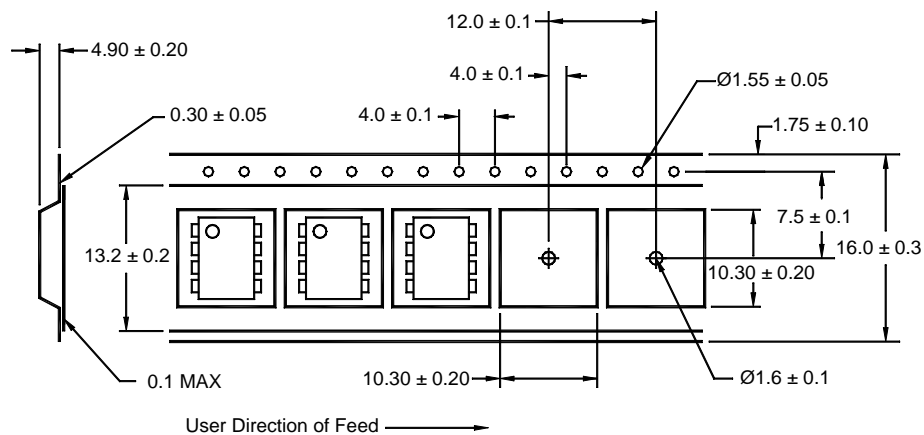

Corporate Headquarters

QT Optoelectronics
 610 North Mary Avenue
 Sunnyvale, CA 94086
 (408) 720-1440 Phone
 (408) 720-0848 Fax

North American Sales

QT Optoelectronics
 16775 Addison Rd., Suite 200
 Addison, TX 75001
 (972) 447-1300 Phone
 (972) 447-0784 Fax

European Sales

Quality Technologies Deutschland GmbH
 Max-Huber-Strasse 8
 D-85737 Ismaning, Germany
 49 [0] 89/96.30.51 Phone
 49 [0] 89/96.54.74 Fax

European Sales

QT Optoelectronics
 "Le Levant"
 2, rue du Nouveau Bercy
 F-94277-CHARENTON-LE PONT Cedex
 FRANCE
 33 [0] 1.45.18.78.78 Phone
 33 [0] 1.43.75.77.57 Fax

Asia/Pacific Sales

QT Optoelectronics
 B613, 6th Floor
 East Wing, Wisma Tractors
 Jalan SS16/1, Subang Jaya
 47500 Petaling Jaya
 Selangor Darul Eshan, Malaysia
 603/735-2417 Phone
 603/736-3382 Fax

European Sales

Quality Technologies (U.K) Ltd.
 10, Prebendal Court, Oxford Road
 Aylesbury, Buckinghamshire
 HP19-3EY United Kingdom
 44 [0] 1296/30.44.99 Phone
 44 [0] 1296/39.24.32 Fax

www.qtopto.com

Call QT Optoelectronics for more information or the phone number of your nearest distributor.

United States 800-533-6786 • France 33 [0] 1.45.18.78.78 • Germany 49 [0] 89/96.30.51 • United Kingdom 44 [0] 1296 394499 • Asia/Pacific 603-7352417