



0.5Ω、四路 SPDT 开关，UCSP/QFN 封装

MAX4754/MAX4755/MAX4756

概述

MAX4754/MAX4755/MAX4756 是低导通电阻模拟开关，采用 +1.8V 至 +5.5V 单电源供电。MAX4754 和 MAX4755 是双路、双刀双掷 (DPDT) 开关。MAX4756 是四路、单刀双掷 (SPDT) 开关。这些器件可以配置用来切换音频或数据信号。

MAX4754 有四个 0.5Ω 的 SPDT 开关，用于音频信号切换，并有两个逻辑控制输入。MAX4755 有四个 0.5Ω 的 SPDT 开关 (两个开关分别在 NC 端加有额外的 11Ω 串联电阻)。这样用户可以将 8Ω 扬声器当作 32Ω 负载 (耳机扬声器) 来驱动。MAX4756 有四个 0.5Ω 的 SPDT 开关，这些开关由一个逻辑控制输入和一个使能引脚控制，使能引脚 (EN) 可用来禁止这些开关。

MAX4754/MAX4755/MAX4756 提供节省空间的 16 引脚、薄型 QFN 封装和微型、16 焊球、2mm x 2mm 晶片级封装 (UCSP™)。

应用

- 扬声器-耳机开关
- 音频信号切换
- 蜂窝电话
- PDA/手持式设备
- 笔记本电脑

特性

- ◆ 数据与音频信号切换
- ◆ 低 R_{ON} (0.5Ω) 音频开关
- ◆ 0.1Ω 通道间匹配度
- ◆ 0.2Ω 导通电阻平坦度
- ◆ 0.02% THD
- ◆ +1.8V 至 +5.5V 电源范围
- ◆ 可处理满摆幅信号
- ◆ 16 焊球 UCSP (2mm x 2mm) 封装

订购信息

PART	TEMP RANGE	PIN-PACKAGE
MAX4754EBE-T	-40°C to +85°C	16 UCSP-16
MAX4754ETE	-40°C to +85°C	16 Thin QFN (4mm x 4mm)
MAX4755EBE-T*	-40°C to +85°C	16 UCSP-16
MAX4755ETE*	-40°C to +85°C	16 Thin QFN (4mm x 4mm)
MAX4756EBE-T*	-40°C to +85°C	16 UCSP-16
MAX4756ETE*	-40°C to +85°C	16 Thin QFN (4mm x 4mm)

* 未来产品 — 供货情况请联系厂商

引脚配置在数据资料的最后部分给出。

UCSP 是 Maxim Integrated Products, Inc. 的商标。

功能框图

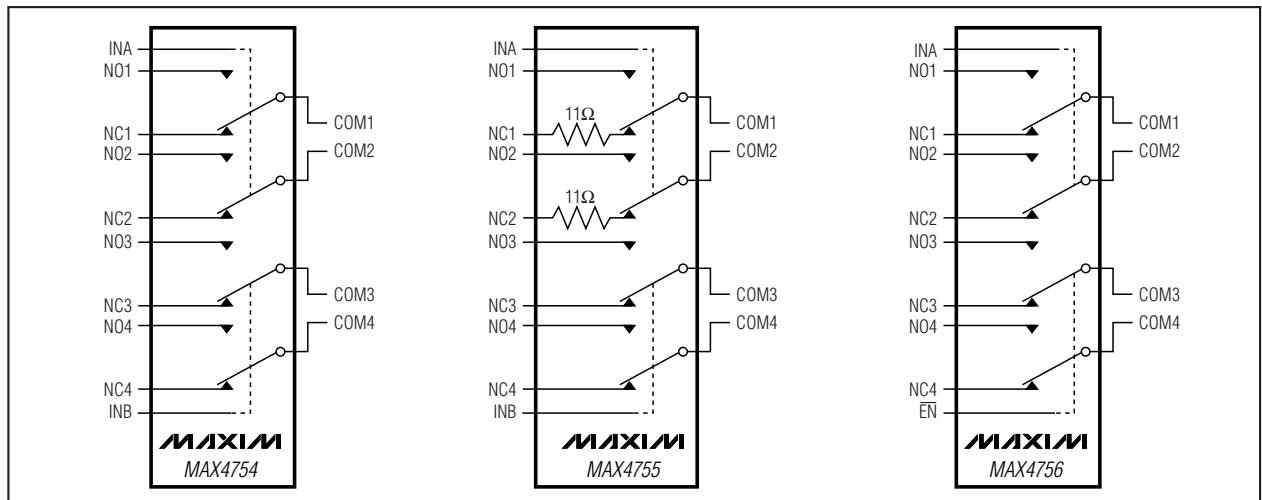

本文是 Maxim 正式英文资料的译文，Maxim 不对翻译中存在的差异或由此产生的错误负责。请注意译文中可能存在文字组织或翻译错误，如需确认任何词语的准确性，请参考 Maxim 提供的英文版资料。

索取免费样品和最新版的数据资料，请访问 Maxim 的主页：www.maxim-ic.com.cn。

0.5Ω、四路 SPDT 开关，UCSP/QFN 封装

ABSOLUTE MAXIMUM RATINGS

(All Voltages Referenced to GND)

V+, IN_, EN_	-0.3V to +6V
COM_, NO_, NC_ (Note 1)	-0.3V to (V+ + 0.3V)
Continuous Current	
NC1, NC2, COM1, COM2 (MAX4755)	±100mA
NO_, NC_, COM_ (remaining terminal connections)	±300mA
Peak Current NC1, NC2, COM1, COM2 (MAX4755)	
(Pulsed at 1ms, 10% duty cycle)	±200mA
(Pulsed at 1ms, 50% duty cycle)	±150mA
Peak Current NO_, NC_,	
COM_ (remaining terminal connections)	
(Pulsed at 1ms, 10% duty cycle)	±500mA
(Pulsed at 1ms, 50% duty cycle)	±400mA

Continuous Power Dissipation (T _A = +70°C)	
16-Bump UCSP (derate 8.2mW/°C above +70°C)	660mW
16-Pin Thin QFN (derate 16.9mW/°C above +70°C)	1349mW
ESD per Method 3015.7	±2kV
Operating Temperature Range	-40°C to +85°C
Junction Temperature	+150°C
Storage Temperature Range	-65°C to +150°C
Bump Temperature (soldering)	
Infrared (15s)	+220°C
Vapor Phase (60s)	+215°C
Lead Temperature (soldering, 10s)	+300°C

Note 1: Signals on NO_, NC_, COM_ exceeding V+ or GND are clamped by internal diodes. Limit forward-diode current to maximum current rating.

Stresses beyond those listed under "Absolute Maximum Ratings" may cause permanent damage to the device. These are stress ratings only, and functional operation of the device at these or any other conditions beyond those indicated in the operational sections of the specifications is not implied. Exposure to absolute maximum rating conditions for extended periods may affect device reliability.

ELECTRICAL CHARACTERISTICS

(V+ = +2.7V to +5.25V, T_A = -40°C to +85°C, unless otherwise noted. Typical values are at +3V and T_A = +25°C.) (Notes 2, 3)

PARAMETER	SYMBOL	CONDITIONS		T _A	MIN	TYP	MAX	UNITS
ANALOG SWITCH								
Analog Signal Range	V _{COM_} , V _{NO_} , V _{NC_}			T _{MIN} to T _{MAX}	0		V+	V
On-Resistance	R _{ON}	V+ = 2.7V, I _{COM_} = 10mA, V _{NC_} = 0V, or V _{NC_} = V+ (Note 4)	MAX4755 (NO1, NO2, N_3, N_4), MAX4754/MAX4756	+25°C		0.5	0.85	Ω
				T _{MIN} to T _{MAX}			1.0	
			MAX4755 (NC1, NC2)	+25°C		11.5		
				T _{MIN} to T _{MAX}	8.0		12.5	
On-Resistance Match Between Channels	ΔR _{ON}	V+ = 2.7V, I _{COM_} = 10mA, V _{NO_} = 1.5V, or V _{NC_} = 1.5V (Notes 4, 5)	MAX4755 (NO1, NO2, N_3, N_4), MAX4754/MAX4756	+25°C		0.1	0.35	Ω
				T _{MIN} to T _{MAX}			0.55	
			MAX4755 (NC1, NC2)	+25°C		0.2	0.4	
				T _{MIN} to T _{MAX}			0.55	
On-Resistance Flatness	R _{FLAT(ON)}	V+ = 3V, I _{COM_} = 10mA, V _{NO_} = 0V, or V _{NC_} = V+ (Note 6)	MAX4755 (NO1, NO2, N_3, N_4, NO1, NO2), MAX4754/MAX4756	+25°C		0.2	0.4	Ω
			T _{MIN} to T _{MAX}			0.55		
NO_, NC_ Off-Leakage Current	I _{NO_(OFF)} , I _{NC_(OFF)}	V+ = 3.6V; V _{COM_} = 3.3V, 0.3V; V _{NO_} or V _{NC_} = 0.3V, 3.3V		+25°C	-3		+3	nA
				T _{MIN} to T _{MAX}	-10		+10	
COM_ Off-Leakage Current	I _{COM_(OFF)}	V+ = 3.6V (MAX4756); V _{COM_} = 3.3V, 0.3V; V _{NO_} or V _{NC_} = 0.3V, 3.3V		+25°C	-3	±0.01	+3	nA
				T _{MIN} to T _{MAX}	-10		+10	

0.5Ω、四路 SPDT 开关，UCSP/QFN 封装

ELECTRICAL CHARACTERISTICS (Continued)(V+ = +2.7V to +5.25V, T_A = -40°C to +85°C, unless otherwise noted. Typical values are at +3V and T_A = +25°C.) (Notes 2, 3)

PARAMETER	SYMBOL	CONDITIONS	T _A	MIN	TYP	MAX	UNITS
COM_ On-Leakage Current	I _{COM_(ON)}	V+ = 3.6V; V _{COM_} = 3.3V, 0.3V; V _{NO_} or V _{NC_} = 3.3V, 0.3V or floating	+25°C	-3		+3	nA
			T _{MIN} to T _{MAX}	-10		+10	
DYNAMIC							
Turn-On Time	t _{ON}	V+ = 2.7V, V _{NO_} or V _{NC_} = 1.5V; R _L = 50Ω; C _L = 35pF, Figure 1	+25°C	45		140	ns
			T _{MIN} to T _{MAX}			150	
Turn-Off Time	t _{OFF}	V+ = 2.7V, V _{NO_} or V _{NC_} = 1.5V; R _L = 50Ω; C _L = 35pF, Figure 1	+25°C	25		50	ns
			T _{MIN} to T _{MAX}			60	
Break-Before-Make	t _{BBM}	V+ = 2.7V, V _{NO_} or V _{NC_} = 1.5V; R _L = 50Ω, C _L = 35pF, Figure 2 (Note 7)	+25°C	15			ns
			T _{MIN} to T _{MAX}	2			
Charge Injection	Q	V _{GEN} = 0V, R _{GEN} = 0, C _L = 1.0nF, Figure 3	+25°C		50		pC
On-Channel -3dB Bandwidth	BW	Signal = 0dBm, C _L = 50pF, R _L = 50Ω,	+25°C		325		MHz
Off-Isolation	V _{ISO}	C _L = 5pF, R _L = 50Ω, V _{COM_} = 1VP-P f = 100kHz, Figure 4 (Note 8)	+25°C		-120		dB
Crosstalk	V _{CT}	C _L = 5pF, R _L = 50Ω, V _{COM_} = 1VP-P f = 100kHz, Figure 4 (Note 9)	+25°C		-120		dB
Total Harmonic Distortion	THD	f = 20Hz to 20kHz, 1VP-P, R _L = 32Ω	+25°C		0.02		%
NO_, NC_ Off-Capacitance	C _{NO_(OFF)} , C _{NC_(OFF)}	V _{NO} , V _{NC_} = GND, f = 1MHz, V _{COM_} = 0.5VP-P, Figure 5	+25°C		65		pF
COM_ Off-Capacitance	C _{COM_(OFF)}	V _{COM_} = GND, f = 1MHz, MAX4756, Figure 5	+25°C		110		pF
COM_ On-Capacitance	C _(ON)	V _{COM_} = V _{NO} , V _{NC_} = GND, f = 1MHz, V _{COM_} = 0.5VP-P, Figure 5	+25°C		168		pF
DIGITAL I/O (IN_, EN)							
Input Logic High	V _{IH}	V+ = 2.7V to 3.6V	T _{MIN} to T _{MAX}	1.4			V
		V+ = 3.6V to 5.25V	T _{MIN} to T _{MAX}	2.0			
Input Logic Low	V _{IL}	V+ = 2.7V to 3.6V	T _{MIN} to T _{MAX}			0.5	V
		V+ = 3.6V to 5.25V	T _{MIN} to T _{MAX}			0.6	
Input Leakage Current	I _{IN}	V _{IN} = 0V or V+	T _{MIN} to T _{MAX}			1	μA

0.5Ω、四路 SPDT 开关，UCSP/QFN 封装

MAX4754/MAX4755/MAX4756

ELECTRICAL CHARACTERISTICS (Continued)

(V+ = +2.7V to +5.25V, T_A = -40°C to +85°C, unless otherwise noted. Typical values are at +3V and T_A = +25°C.) (Notes 2, 3)

PARAMETER	SYMBOL	CONDITIONS	T _A	MIN	TYP	MAX	UNITS
POWER SUPPLY							
Power-Supply Range	V+		T _{MIN} to T _{MAX}	1.8		5.5	V
Positive-Supply Current	I+	V+ = 5.5V, V _{IN-} = 0V or V+	+25°C	0.001			μA
			T _{MIN} to T _{MAX}			1.0	

Note 2: The algebraic convention is used in this data sheet; the most negative value is shown in the minimum column.

Note 3: UCSP parts are 100% tested at +25°C and limits across the full temperature range are guaranteed by correlation and design. Thin QFN parts are 100% tested at +85°C and limits across the full temperature range are guaranteed by correlation and design.

Note 4: R_{ON} and ΔR_{ON} matching specifications are guaranteed by design.

Note 5: ΔR_{ON} = R_{ON(MAX)} - R_{ON(MIN)}.

Note 6: Flatness is defined as the difference between the maximum and minimum value of on-resistance as measured over the specified analog signal ranges.

Note 7: Guaranteed by design, not production tested.

Note 8: Off-Isolation = 20log₁₀ [V_{COM} / (V_{NO} or V_{NC})], V_{COM} = output, V_{NO} or V_{NC} = input to off switch.

Note 9: Between any two switches.

0.5Ω、四路 SPDT 开关，UCSP/QFN 封装

典型工作特性

(V+ = 3V, TA = +25°C, unless otherwise noted.)

MAX4754/MAX4755/MAX4756

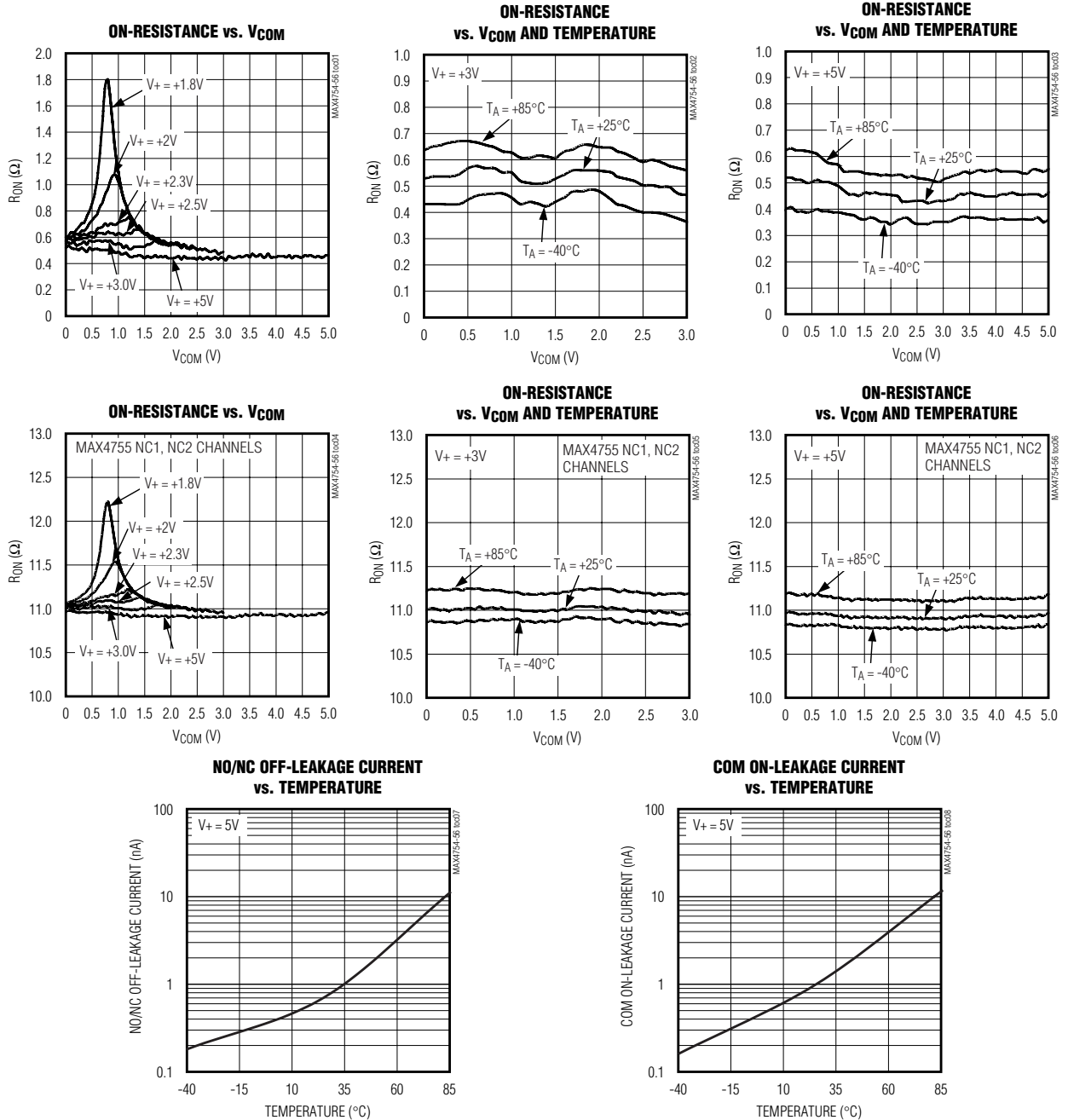

0.5Ω、四路 SPDT 开关，UCSP/QFN 封装

典型工作特性 (续)

(V+ = 3V, TA = +25°C, unless otherwise noted.)

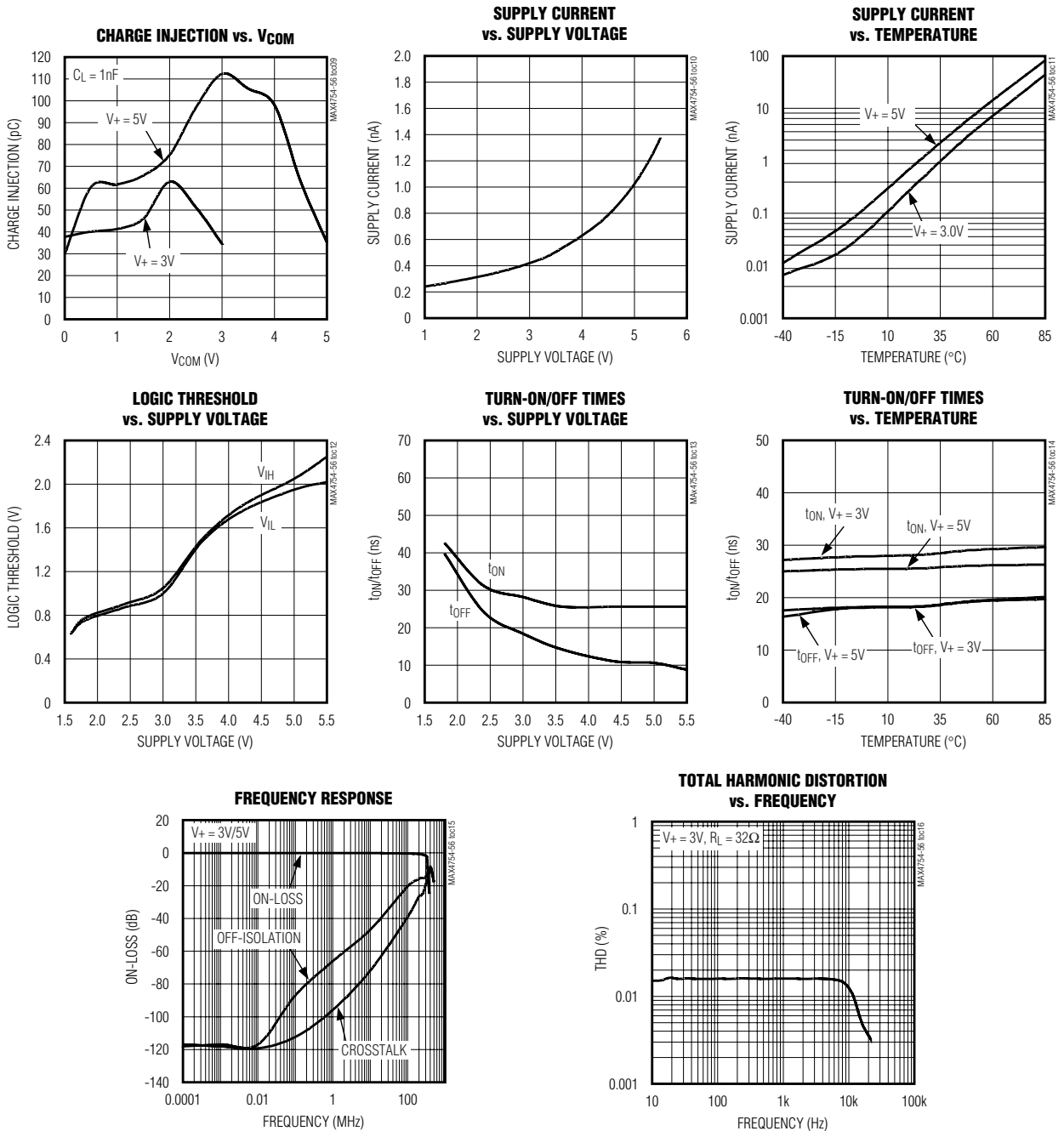

0.5Ω、四路 SPDT 开关，UCSP/QFN 封装

引脚说明

引脚						名称	功能
MAX4754		MAX4755		MAX4756			
UCSP	QFN	UCSP	QFN	UCSP	QFN		
C1	1	C1	1	C1	1	NO1	模拟开关 1，常开端 1。
C2	2	C2	2	C2	2	INA	开关 1 和 2 的逻辑控制数字输入。MAX4756 中开关 1-4 的数控输入。
B1	3	B1	3	B1	3	COM1	模拟开关 1，公共端 1。
A1	4	A1	4	A1	4	NC1	模拟开关 1，常闭端 1。
A2	5	A2	5	A2	5	NO4	模拟开关 4，常开端 4。
B2	6	B2	6	B2	6	V+	正电源输入
A3	7	A3	7	A3	7	COM4	模拟开关 4，公共端 4。
A4	8	A4	8	A4	8	NC4	模拟开关 4，常闭端 4。
B4	9	B4	9	B4	9	NO2	模拟开关 2，常开端 2。
B3	10	B3	10	—	—	INB	开关 3 和 4 的逻辑控制数字输入
—	—	—	—	B3	10	EN	输出使能，低电平有效。
C4	11	C4	11	C4	11	COM2	模拟开关 2，公共端 2。
D4	12	D4	12	D4	12	NC2	模拟开关 2，常闭端 2。
D3	13	D3	13	D3	13	NO3	模拟开关 3，常开端 3。
C3	14	C3	14	C3	14	GND	地
D2	15	D2	15	D2	15	COM3	模拟开关 3，公共端 3。
D1	16	D1	16	D1	16	NC3	模拟开关 3，常闭端 3。
—	PAD	—	PAD	—	PAD	EP	裸露焊盘，与 GND 相连。

MAX4754/MAX4755/MAX4756

典型工作电路

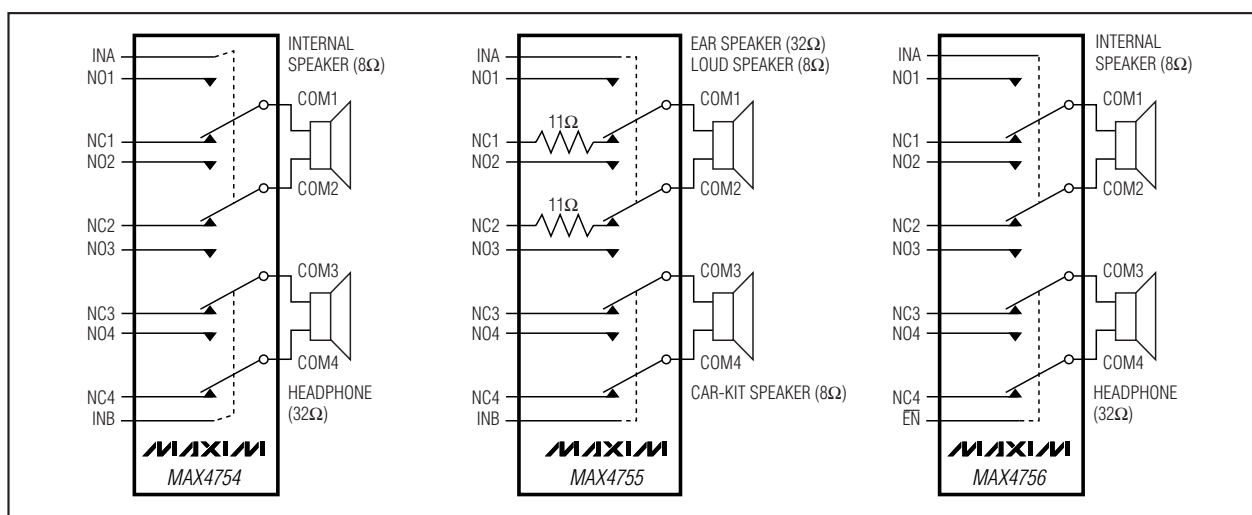

0.5Ω、四路 SPDT 开关，UCSP/QFN 封装

详细说明

MAX4754/MAX4755/MAX4756 是低导通电阻模拟开关，采用 +1.8V 至 +5.5V 单电源供电。这些器件完全规范于电源标称值为 3V 的应用。

MAX4754 DPDT 开关有两个逻辑控制输入，每个输入控制两个 SPDT 开关。每个开关的 NO 和 NC 端的导通电阻为 0.5Ω，这使其非常适合音频信号切换。

MAX4755 DPDT 开关也有四个 0.5Ω 的 SPDT 开关，开关 1 和 2 的 NC 端还加有 11.5Ω 的串联电阻。该特性允许用户将 8Ω 扬声器当作 32Ω 负载来驱动，使之可以作为耳机扬声器来使用。使用两个逻辑控制输入控制四个开关。

MAX4756 有四个 0.5Ω 的 SPDT 开关，由一个逻辑控制输入 (INA) 和一个 $\overline{\text{EN}}$ 输入来控制， $\overline{\text{EN}}$ 输入用来禁止开关。

应用信息

数控输入

无论采用何种电源电压，MAX4754/MAX4755/MAX4756 的逻辑输入端都可以承受最大 +5.5V 的电压。例如在 +3.3V 供电时，IN_ 端可以低至 GND，也可以高至 +5.5V，这就允许混合逻辑电平共存于同一个系统中。满摆幅驱动控制逻辑输入可将功耗降至最低。在 +3V 电源电压下，逻辑电平门限值为 0.5V (低) 和 1.4V (高)。

对于 MAX4756，将 $\overline{\text{EN}}$ 驱动至低电平使能 COM_。当 $\overline{\text{EN}}$ 为高电平时，COM_ 为高阻状态。

模拟信号电平

整个供电电压范围内 (0V 到 V+) 的模拟信号输入都可通过开关，且导通电阻变化极小 (见典型工作特性)。开关是双向的，因此 NO_、NC_ 和 COM_ 既可作为输入也可作为输出。

电源旁路

电源旁路能够改善噪声容限，并能阻止开关噪声从 V+ 电源传播到其他器件。在 V+ 和 GND 之间连接一个 0.1μF 电容即可满足大多数应用的要求。

UCSP 应用信息

关于 UCSP 结构、尺寸、载带信息、印刷电路板技术、焊盘布局、推荐的回流焊温度特性，以及可靠性测试结果的最新应用数据，可从 Maxim 网站 www.maxim-ic.com.cn/ucsp 下载应用笔记：UCSP—晶片级封装。

0.5Ω、四路 SPDT 开关，UCSP/QFN 封装

测试电路/时序图



图 1. 开关时间



图 2. 先断后合的间隔

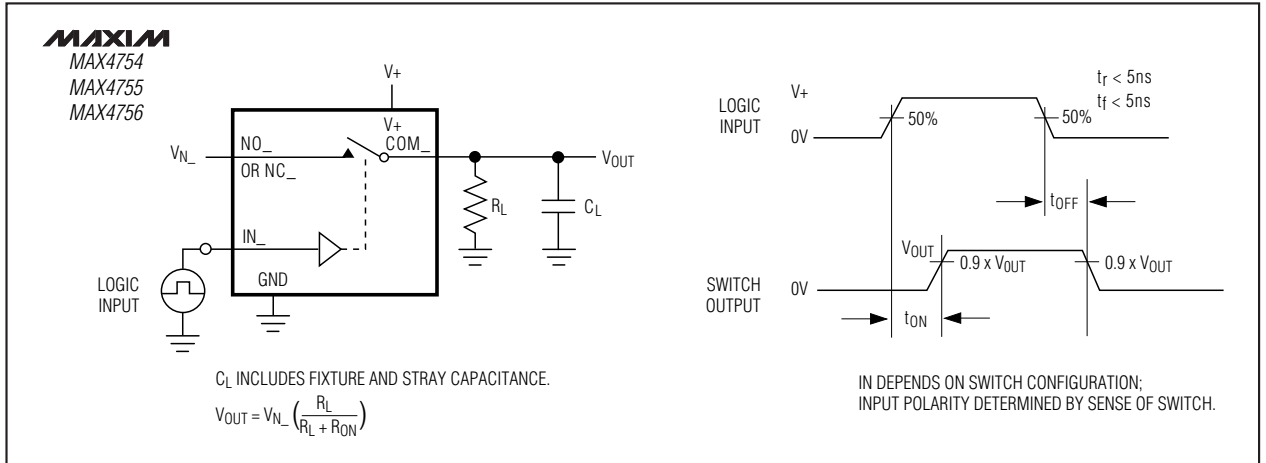

图 3. 电荷注入

0.5Ω、四路 SPDT 开关，UCSP/QFN 封装

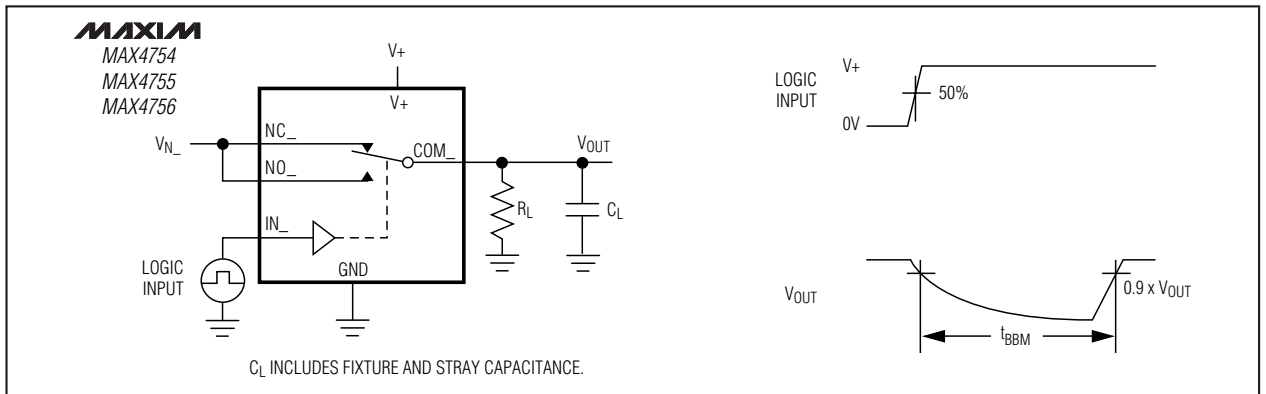
测试电路/时序图(续)

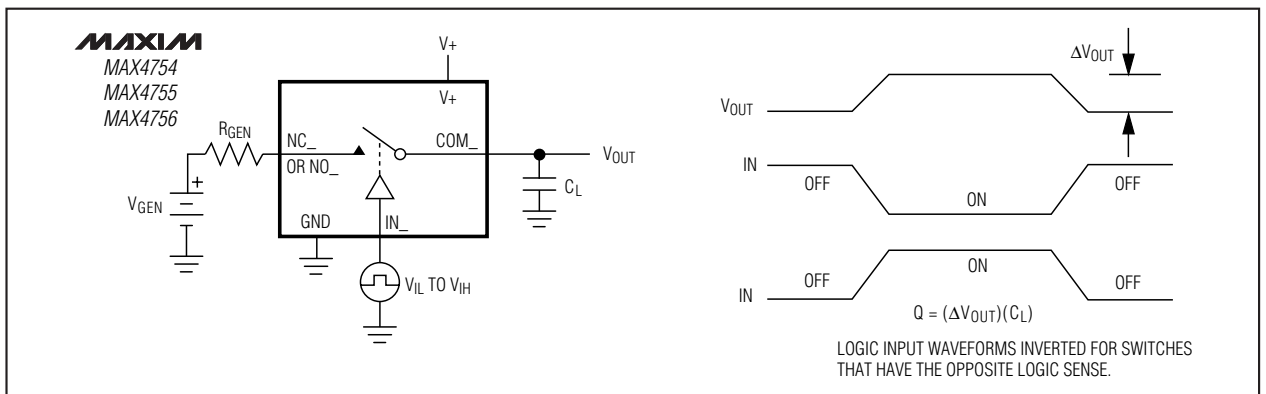

图 4. 导通损耗、关断隔离和串扰



图 5. 通道开/关电容

MAX4754/MAX4755/MAX4756

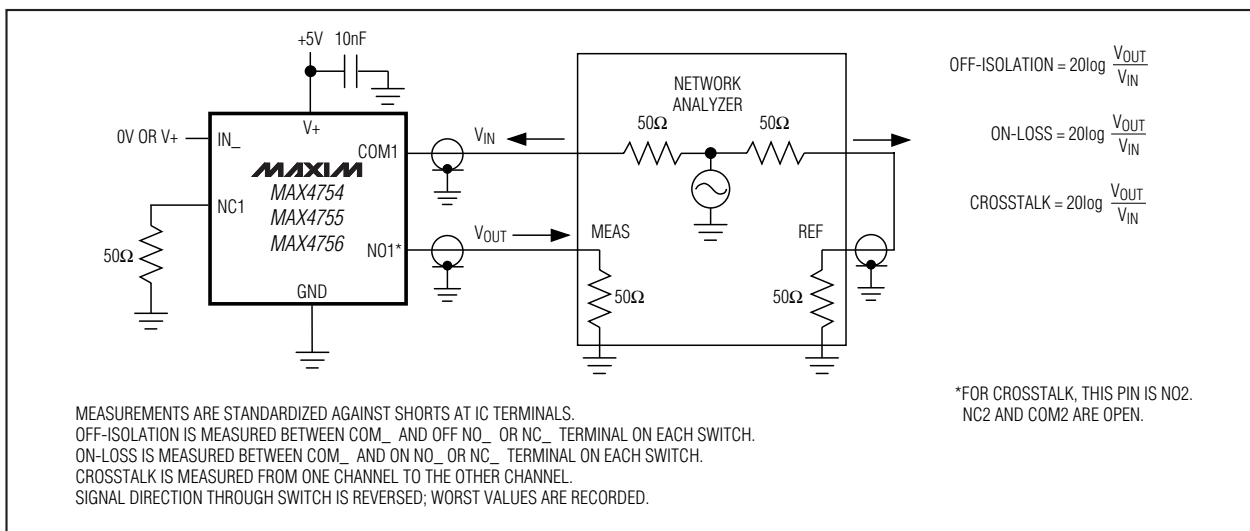
0.5Ω、四路 SPDT 开关，UCSP/QFN 封装

引脚配置/真值表

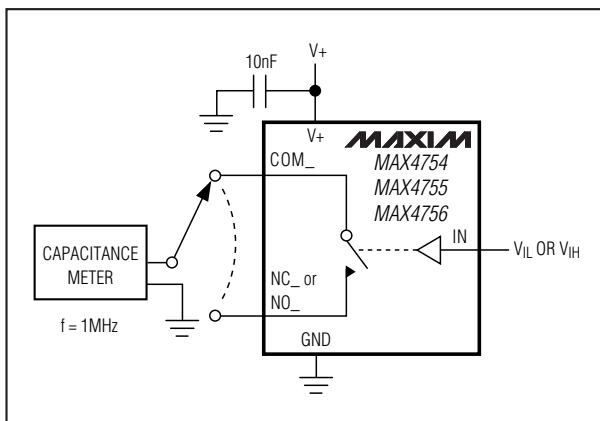
TOP VIEW
(BUMP SIDE DOWN)

MAXIM
MAX4754/MAX4755/MAX4756

() FOR MAX4756. **UCSP**

INA	NO1/NO2	NC1/NC2	NO3/NO4	NC3/NC4
LOW	OFF	ON	—	—
HIGH	ON	OFF	—	—
INB				
LOW	—	—	OFF	ON
HIGH	—	—	ON	OFF

MAXIM
MAX4754
MAX4755
MAX4756

THIN QFN

NOTE: EXPOSED PADDLE CONNECTED TO GND.

EN	INA	NO_	NC_
LOW	LOW	OFF	ON
LOW	HIGH	ON	OFF
HIGH	X	OFF	OFF
HIGH	X	OFF	OFF

MAX4754/MAX4755/MAX4756

芯片信息

TRANSISTOR COUNT: 496

PROCESS: CMOS

0.5Ω、四路 SPDT 开关，UCSP/QFN 封装

封装信息

(本数据资料提供的封装图可能不是最近的规格，如需最近的封装外型信息，请查询 www.maxim-ic.com.cn/packages。)

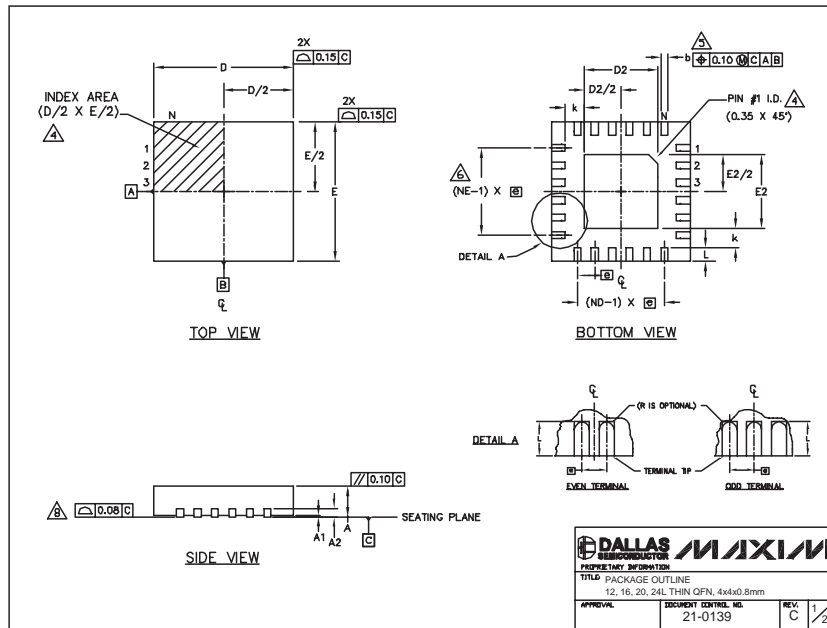

24L QFN THINERS

COMMON DIMENSIONS												
PKG	12L 4x4			16L 4x4			20L 4x4			24L 4x4		
REF.	MIN.	NDM.	MAX.	MIN.	NDM.	MAX.	MIN.	NDM.	MAX.	MIN.	NDM.	MAX.
a	0.70	0.75	0.80	0.70	0.75	0.80	0.70	0.75	0.80	0.70	0.75	0.80
AL	0.0	0.02	0.05	0.0	0.02	0.05	0.0	0.02	0.05	0.0	0.02	0.05
A2	0.20 REF.			0.20 REF.			0.20 REF.			0.20 REF.		
b	0.25	0.30	0.35	0.25	0.30	0.35	0.20	0.25	0.30	0.18	0.23	0.30
D	3.90	4.00	4.10	3.90	4.00	4.10	3.90	4.00	4.10	3.90	4.00	4.10
E	3.90	4.00	4.10	3.90	4.00	4.10	3.90	4.00	4.10	3.90	4.00	4.10
e	0.80 BSC.			0.65 BSC.			0.50 BSC.			0.50 BSC.		
k	0.25	-	-	0.25	-	-	0.25	-	-	0.25	-	-
L	0.45	0.55	0.65	0.45	0.55	0.65	0.45	0.55	0.65	0.30	0.40	0.50
N	12			16			20			24		
ND	3			4			5			6		
NE	3			4			5			6		
JEDEC Wgr.	WGGB			WGGC			WGGB-1			WGGB-2		

EXPOSED PAD VARIATIONS												
PKG CODES	D2			E2			DOWN BONDS ALLOWED					
	MIN.	NDM.	MAX.	MIN.	NDM.	MAX.						
T1244-2	1.95	2.10	2.25	1.95	2.10	2.25	NO					
T1244-3	1.95	2.10	2.25	1.95	2.10	2.25	YES					
T1244-4	1.95	2.10	2.25	1.95	2.10	2.25	NO					
T1644-2	1.95	2.10	2.25	1.95	2.10	2.25	NO					
T1644-3	1.95	2.10	2.25	1.95	2.10	2.25	YES					
T1644-4	1.95	2.10	2.25	1.95	2.10	2.25	NO					
T2044-1	1.95	2.10	2.25	1.95	2.10	2.25	NO					
T2044-2	1.95	2.10	2.25	1.95	2.10	2.25	YES					
T2044-3	1.95	2.10	2.25	1.95	2.10	2.25	NO					
T2444-1	2.45	2.60	2.63	2.45	2.60	2.63	NO					
T2444-2	1.95	2.10	2.25	1.95	2.10	2.25	YES					
T2444-3	2.45	2.60	2.63	2.45	2.60	2.63	YES					
T2444-4	2.45	2.60	2.63	2.45	2.60	2.63	NO					

NOTES:

1. DIMENSIONING & TOLERANCING CONFORM TO ASME Y14.5M-1994.
2. ALL DIMENSIONS ARE IN MILLIMETERS. ANGLES ARE IN DEGREES.
3. N IS THE TOTAL NUMBER OF TERMINALS.
4. THE TERMINAL #1 IDENTIFIER AND TERMINAL NUMBERING CONVENTION SHALL CONFORM TO JEDEC 95-1 SFF-012. DETAILS OF TERMINAL #1 IDENTIFIER ARE OPTIONAL, BUT MUST BE LOCATED WITHIN THE ZONE INDICATED. THE TERMINAL #1 IDENTIFIER MAY BE EITHER A MOLD OR MARKED FEATURE.
5. DIMENSION b APPLIES TO METALLIZED TERMINAL AND IS MEASURED BETWEEN 0.25 mm AND 0.30 mm FROM TERMINAL TIP.
6. ND AND NE REFER TO THE NUMBER OF TERMINALS ON EACH D AND E SIDE RESPECTIVELY.
7. DEPOPULATION IS POSSIBLE IN A SYMMETRICAL FASHION.
8. COPLANARITY APPLIES TO THE EXPOSED HEAT SINK SLUG AS WELL AS THE TERMINALS.
9. DRAWING CONFORMS TO JEDEC M0220, EXCEPT FOR T2444-1, T2444-3 AND T2444-4.