

**VICOR CONFIDENTIAL**

THIS DOCUMENT AND THE DATA DISCLOSED HEREIN OR HEREWITH IS NOT TO BE REPRODUCED, USED, OR DISCLOSED IN WHOLE OR IN PART TO ANYONE WITHOUT PERMISSION OF VICOR CORP.

REV.	DESCRIPTION	DATE	APPROVED
#1	DRAWN FOR DEVELOPMENT	DMC 4/00	JH

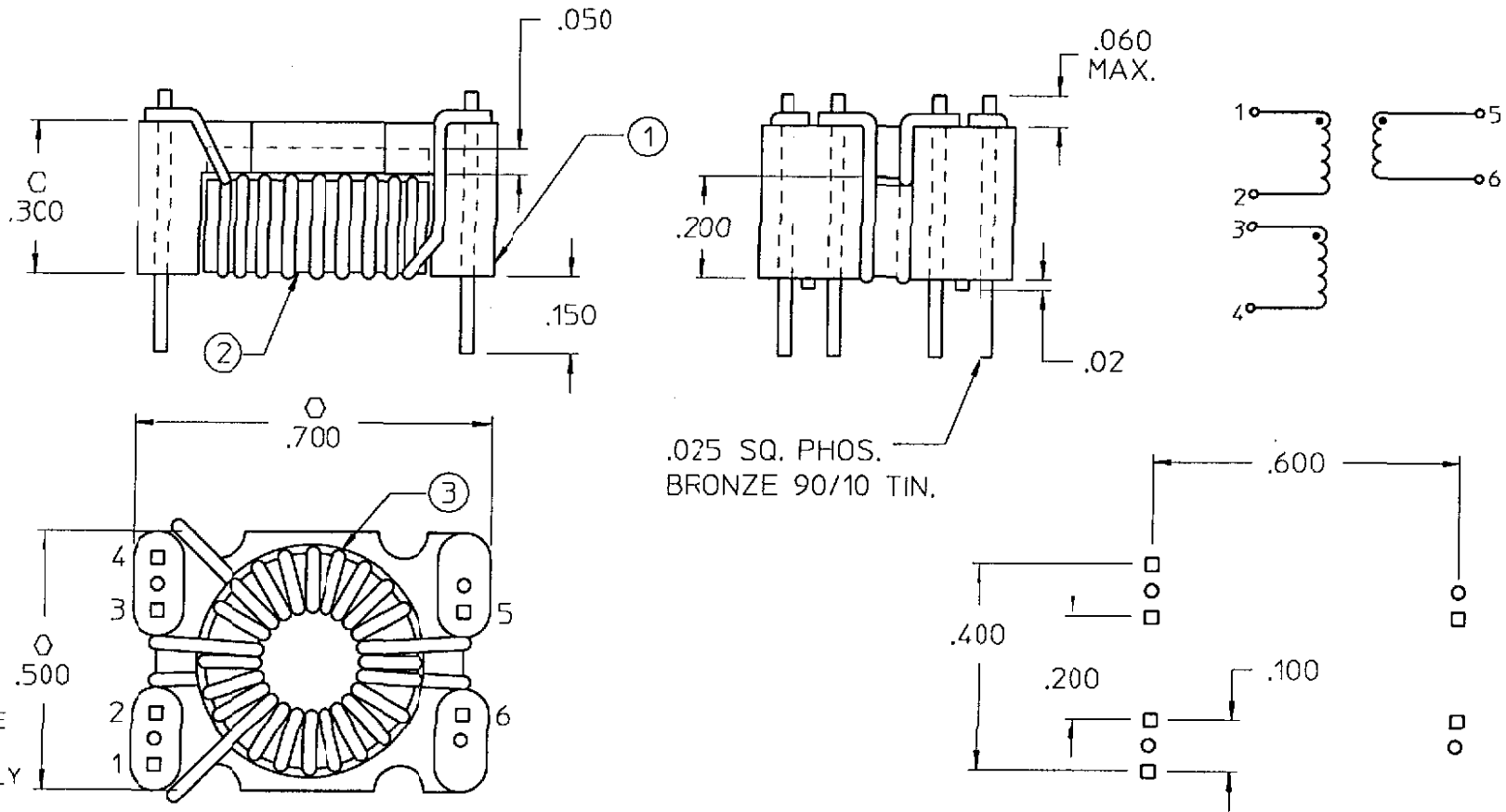

- NOTES:
1. ASSEMBLY TO BE FREE OF NICKS.
  2. WINDINGS TO BE EVENLY SPACED.
  3. SEE BOM 22400 FOR PARTS LIST.

TEST	PINS	NO	WINDNG	NO OF TURNS	IND. (uH)	DC RES (m $\Omega$ )
100 KHz @ 1 VAC	1&2	3	1/2 PRI.	8T OF #29 AWG.	101 - 187	40 - 50
	3&4	3	1/2 PRI.	8T OF #29 AWG.	101 - 187	40 - 50
	5&6	3	1 SEC.	8T OF #29 AWG.	101 - 187	40 - 50

**COPY**

ORIGINAL ONLY WHEN STAMPED IN RED

DRAWN BY	DATE
	4/00
UNLESS OTHERWISE SPECIFIED DIMENSIONS ARE IN INCHES. TOLERANCES ARE:	
FRACTIONS DECIMALS ANGLES	
+1/64 .XX- .01 .1°	
.XXX- .005	
THIRD ANGLE PROJECTION	
DO NOT SCALE DRAWING	

**PR BUS ISO TRANSFORMER ASSEMBLY**

SIZE	FSCM NO.	DWG NO	REV
<b>B</b>	<b>67131</b>	<b>22401</b>	<b># 1</b>
SCALE	4:1	SHEET 1 OF 1	