



2SC3648

NPN EPITAXIAL SILICON TRANSISTOR

HIGH-VOLTAGE SWITCHING PREDRIVER APPLICATIONS

■ FEATURES

- * High breakdown voltage and large current capacity
- * Fast switching speed
- * Over Current Protection Function

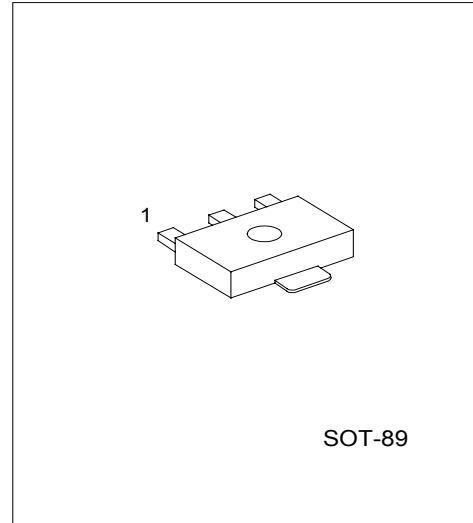

*Pb-free plating product number: 2SC3648L

■ PIN CONFIGURATION

PIN NO.	PIN NAME
1	Emitter
2	Collector
3	Base

■ ORDERING INFORMATION

Order Number		Package	Packing
Normal	Lead free		
2SC3648-AB3-R	2SC3648L-AB3-R	SOT-89	Tape Reel

■ ABSOLUTE MAXIMUM RATINGS (Ta = 25°C)

PARAMETER	SYMBOL	RATINGS	UNIT
Collector to Base Voltage	V_{CBO}	180	V
Collector to Emitter Voltage	V_{CEO}	160	V
Emitter to Base Voltage	V_{EBO}	6	V
Collector Current	I_C	0.7	A
Collector Current (Pulse)	I_{CP}	1.5	A
Collector Dissipation	P_C (Mounted on ceramic board 250mm ² × 0.8mm)	1.3	W
	P_C	500	mW
Junction Temperature	T_J	150	°C
Storage Temperature	T_{STG}	-40 ~ +150	°C

■ ELECTRICAL CHARACTERISTICS (Ta = 25°C, unless otherwise specified)

PARAMETER	SYMBOL	TEST CONDITIONS	MIN	TYP	MAX	UNIT
C-E Saturation Voltage	$V_{CE(sat)}$	$I_C = 250mA, I_B = 25mA$		0.12	0.4	V
B-E Saturation Voltage	$V_{BE(sat)}$	$I_C = 250mA, I_B = 25mA$		0.85	1.2	V
C-B Breakdown Voltage	$V_{(BR)CBO}$	$I_C = 10\mu A, I_E = 0$	180			V
C-E Breakdown Voltage	$V_{(BR)CEO}$	$I_C = 1, R_{BE} = \infty$	160			V
E-B Breakdown Voltage	$V_{(BR)EBO}$	$I_E = 10\mu A, I_C = 0$	6			V
Collector Cutoff Current	I_{CBO}	$V_{CB} = 120V, I_E = 0$			0.1	μA
Emitter Cutoff Current	I_{EBO}	$V_{EB} = 4V, I_C = 0$			0.1	μA
Output Capacitance	C_{ob}	$V_{CB} = 10V, f = 1MHz$		8		pF
DC Current Gain	h_{FE1}	$V_{CE} = 5V, I_C = 100mA$	100		400	
	h_{FE2}	$V_{CE} = 5V, I_C = 10mA$	90			
Turn-on Time	t_{ON}	See specified Test circuit		50		ns
Storage Time	t_{STG}	See specified Test circuit		1000		ns
Fall Time	t_F	See specified Test circuit		60		ns
Gain-Bandwidth Product	f_T	$V_{CE} = 5V, I_C = 50mA$		120		MHz

■ CLASSIFICATION OF $h_{FE} 1$

RANK	R	S	T
RANGE	100 ~ 200	140 ~ 280	200 ~ 400

■ SWITCHING TIME TEST CIRCUIT

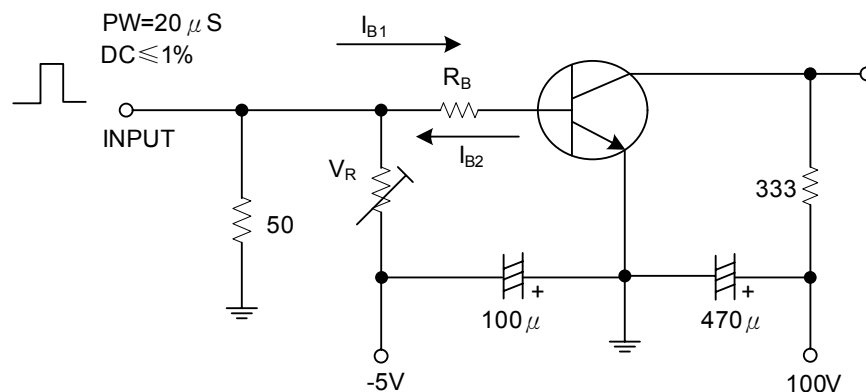

$$20I_{B1} = -20I_{B2} = I_C = 300mA$$

Unit (Resistance: Ω , Capacitance: F)

■ TYPICAL CHARACTERISTICS

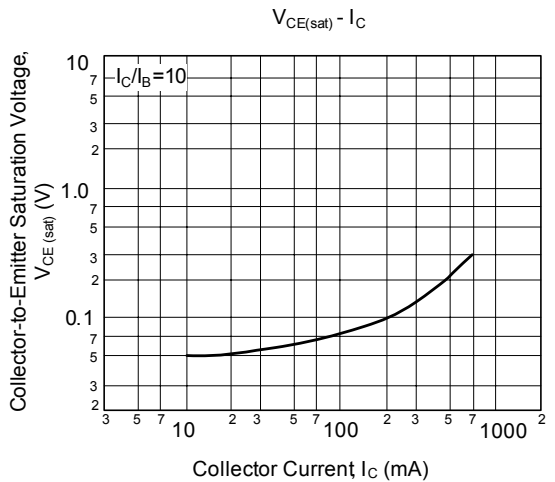
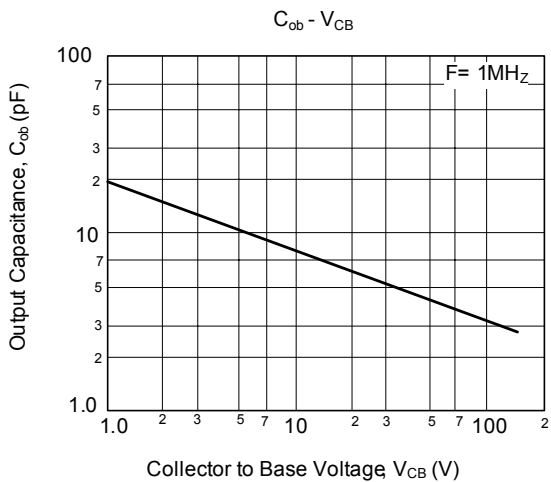
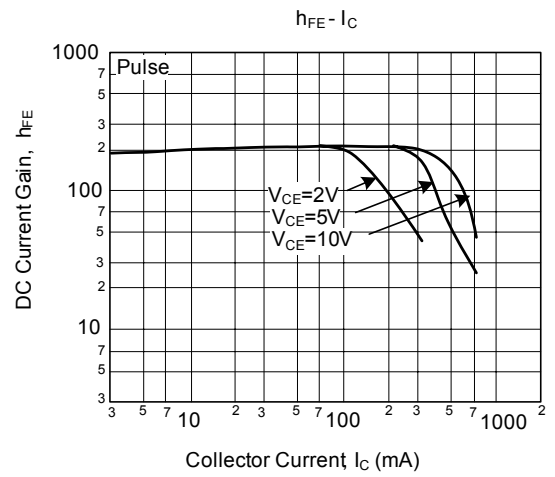
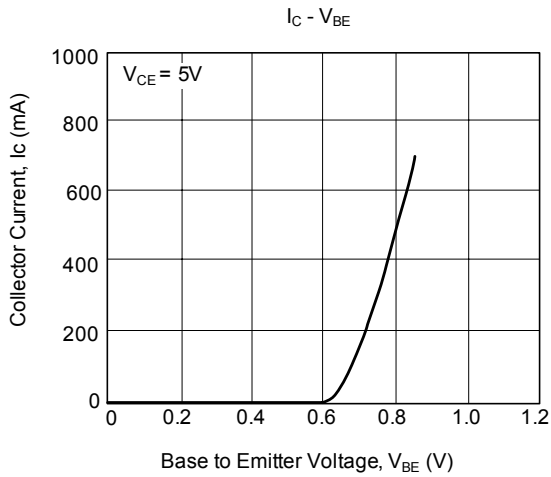
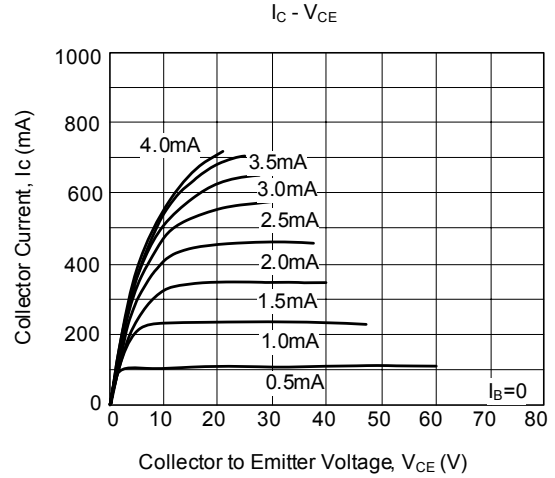
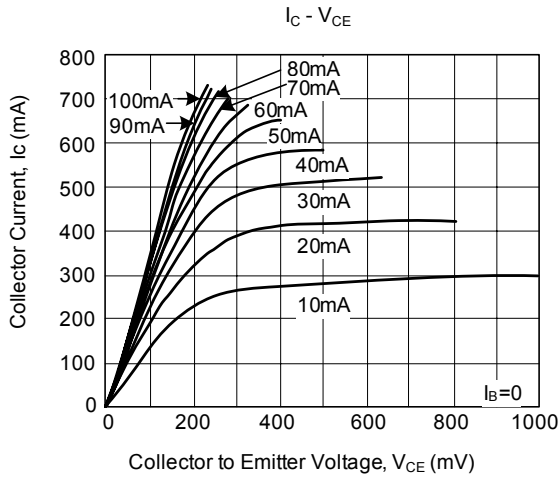

■ TYPICAL CHARACTERISTICS(Cont.)

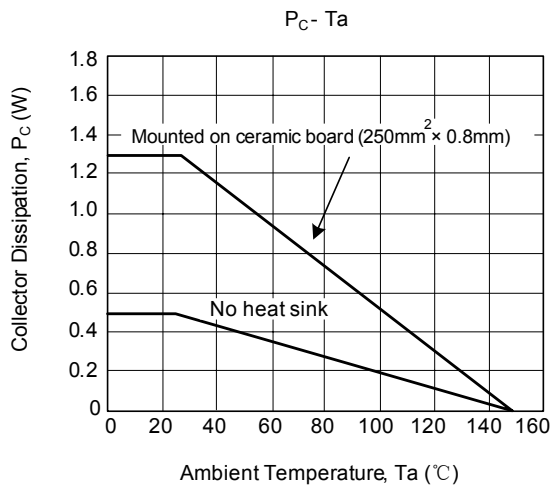
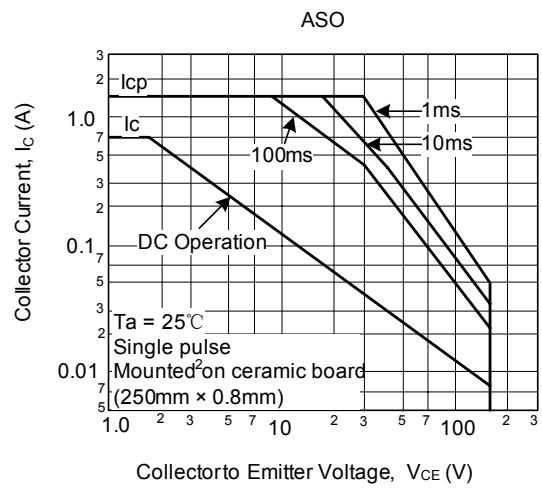
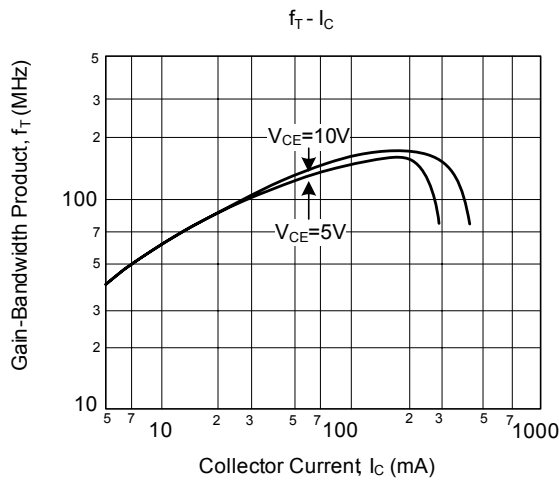

UTC assumes no responsibility for equipment failures that result from using products at values that exceed, even momentarily, rated values (such as maximum ratings, operating condition ranges, or other parameters) listed in products specifications of any and all UTC products described or contained herein. UTC products are not designed for use in life support appliances, devices or systems where malfunction of these products can be reasonably expected to result in personal injury. Reproduction in whole or in part is prohibited without the prior written consent of the copyright owner. The information presented in this document does not form part of any quotation or contract, is believed to be accurate and reliable and may be changed without notice.