



Features

- Bushing mount
- Excellent resolution
- Non-standard features and specifications available
- Small diameter
- High rotational life



Models 3700 and 3701 are currently available, although not recommended for new designs.

BOURNS®

3700/3701 - Precision Potentiometer

Electrical Characteristics¹ 3700 Wirewound Element 3701 Hybritron® Element

Standard Resistance Range	100 to 100 K ohms	1 K to 100 K ohms
Total Resistance Tolerance	±5 %	±10 %
Independent Linearity	±0.25 %	±0.25 %
Effective Electrical Angle	3600° +10°, -0°	3600° +10°, -2°
Absolute Minimum Resistance/	1 ohm or 0.1 % maximum	Minimum voltage
Minimum Voltage	(whichever is greater)	0.2 % maximum
Noise	500 ohms ENR maximum	Output smoothness 0.1 % maximum

Dielectric Withstanding Voltage (MIL-STD-202, Method 301)		
Sea Level	1,000 VAC minimum	1,000 VAC minimum
Power Rating (Voltage Limited By Power Dissipation or 315 VAC, Whichever Is Less)		
+70 °C	1 watt	1 watt
+125 °C	0 watt	0 watt
Insulation Resistance (500 VDC)	1,000 megohms minimum	1,000 megohms minimum
Resolution	See recommended part nos.	Essentially infinite

Environmental Characteristics¹

Operating Temperature Range	+1 °C to +125 °C	+1 °C to +105 °C
Storage Temperature Range	-65 °C to +125 °C	-55 °C to +105 °C
Temperature Coefficient Over		
Storage Temperature Range ²	±50 ppm/°C maximum/unit	±100 ppm/°C maximum/unit
Vibration	20 G	20 G
Wiper Bounce	0.1 millisecond maximum	0.1 millisecond maximum
Shock	100 G	100 G
Wiper Bounce	0.1 millisecond maximum	0.1 millisecond maximum
Load Life	1,000 hours, 1 watt	1,000 hours, 1 watt
Total Resistance Shift	±2 % maximum	±5 % maximum
Rotational Life (No Load)	1,000,000 shaft revolutions ²	4,000,000 shaft revolutions ²
Total Resistance Shift	±5 % maximum	±5 % maximum
Moisture Resistance (MIL-STD-202, Method 103, Condition B)		
Total Resistance Shift	±2 % maximum	±5 % maximum
IP Rating	IP 40	IP 40

Mechanical Characteristics¹

Stop Strength	14 N-cm (20 oz-in.) minimum
Mechanical Angle	3600° +20°, -0°
Torque (Starting & Running)	0.45 N-cm (0.6 oz-in.) max.
Mounting	170-200 N-cm (15-18 lb.-in.) max.
Shaft Runout	0.05 mm (0.002 in.) T.I.R.
Lateral Runout	0.13 mm (0.005 in.) T.I.R.
Shaft End Play	0.13 mm (0.005 in.) T.I.R.
Shaft Radial Play	0.08 mm (0.003 in.) T.I.R.
Pilot Diameter Runout	0.05 mm (0.002 in.) T.I.R.
Backlash	1.0° maximum
Weight	Approximately 28 gm
Terminals	Gold-plated solderlugs (3700) or gold-plated turret lugs (3701)
Soldering Condition	Recommended hand soldering using Sn95/Ag5 no clean solder, 0.025 " wire diameter. Maximum temperature 399 °C (750 °F) for 3 seconds. No wash process to be used with no clean flux.
Marking	Manufacturer's name and part number, resistance value and tolerance, linearity tolerance, wiring diagram, and date code
Ganging (Multiple Section Pots.)	1 cup maximum
Hardware	One lockwasher (H-37-1) and one mounting unit (H-38-1) is shipped with each potentiometer.

¹At room ambient: +25 °C nominal and 50 % relative humidity nominal, except as noted.

²Consult manufacturer for complete specification details.

3700S-1/3701H-1

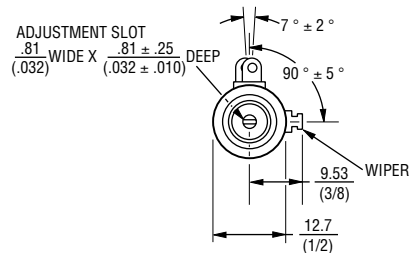
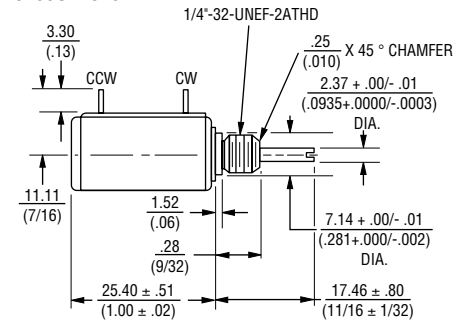

LOCKWASHER AND MOUNTING NUT TO BE SUPPLIED WITH EACH UNIT

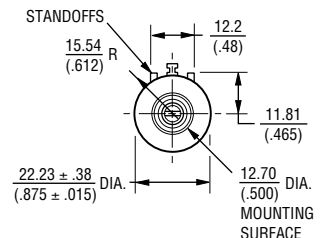

TOLERANCES: EXCEPT WHERE NOTED
 DECIMALS: .XX ± .25 (0.10), .XXX ± .13 (0.05)
 FRACTIONS: ±1/64
 DIMENSIONS: MM (IN)

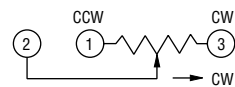

BOLDFACE LISTINGS ARE IN STOCK AND READILY AVAILABLE THROUGH DISTRIBUTION.

FOR OTHER OPTIONS CONSULT FACTORY.

TERMINALS:
 L = RoHS COMPLIANT
 BLANK = STANDARD

Recommended Part Numbers

Part Number	Resistance (Ω)	Resolution
3700S-1-102L	1,000	0.43
3700S-1-202L	2,000	0.35
3700S-1-502L	5,000	0.34
3700S-1-103L	10,000	0.26

Part Number	Resistance (Ω)
3701H-1-102L	1,000
3701H-1-202L	2,000
3701H-1-502L	5,000
3701H-1-103L	10,000

REV. 06/06

*RoHS Directive 2002/95/EC Jan 27 2003 including Annex Specifications are subject to change without notice. Customers should verify actual device performance in their specific applications.