

Features:

- Designed for 100 krad(Si) Total Dose
- Hermetically Sealed Package
- 2A Peak Output Current
- Built-in High-Side Gate Drive Circuit
- N- and P-channel MOSFETs for Ease of Drive
- Electrically Isolated Package
- Interface Directly with UC1625 Motor Controller

Applications:

- 3-Phase BLDC Motor Control
- Fin Actuator Control
- Antenna Deployment Control
- Mirror Position Control
- X-Y Table Control
- Gimbal Stabilization Platform
- Guidance System

DESCRIPTION

The 42144 Full Bridge Power Driver Hybrid is designed for high reliability applications in harsh environment. This compact design offers a full-bridge power driver stage for three-phase brushless DC motor applications. The circuit is electrically isolated from the metal case for ease of mounting in the system. The hybrid package provides two mounting ears for ease of assembly and low thermal resistance path. Each phase contains a high-side gate drive circuit for the P-channel power MOSFET, a series gate resistor for the low-side N-channel power MOSFET, and three Schottky diodes. The high-side gate drive circuit accepts an open-collector signal of the application controller circuit and generates required gate voltage to operate the high-side MOSFET. The low-side gate resistor will prevent any oscillations and minimize ringing. As an option, a Schottky diode in series with the low-side MOSFET insures that braking current will not flow backward through the N-channel MOSFET. Sources of the low-side MOSFETs are terminated individually allowing user to configure the desired current sensing option.

Micropac 42144 Full Bridge Power Driver Hybrid employed selected components that are capable to perform in radiation environment with minimum degradation. The hybrid will perform over the full military temperature range of -55°C to +125°C. It is fabricated using DSCC certified manufacturing processes that are fully in compliance with MIL-PRF-38534. This device is available in a variety of quality levels from COTS to Class K including any custom screening requirements. The basic data sheet part is environmentally screened to H level in accordance with Table C-IX of MIL-PRF-38534.

ABSOLUTE MAXIMUM RATINGS

Supply Voltage, $V_M$ .....	60 VDC
Peak Pulsed Output Current (< 1% duty cycle) .....	5 A
Dielectric Withstanding Voltage .....	500 VDC
Storage Temperature Range .....	-65°C to +150°C
Operating Junction Temperature .....	-55°C to +150°C
Lead Solder Temperature for 10 seconds .....	300°C
Junction-to case thermal resistance, $\theta_{J-C}$ .....	TBD °C/W
Case Temperature .....	125°C

WEIGHT: .....TBD grams (typical)

<p>Micropac Industries cannot assume any responsibility for any circuits shown or represent that they are free from patent infringement. Micropac reserves the right to make changes at any time in order to improve design and to supply the best product possible.</p>
--

**RECOMMENDED OPERATING CONDITIONS:**

Parameter	Symbol	Min.	Max.	Units
Motor Supply Voltage	$V_M$		50	VDC
Continuous Output Current	$I_{O(ON)}$		2	A
Input Voltage (off)	$V_{F(OFF)}$	0	1	VDC
Operating Case Temperature	$T_C$	-55	125	°C

**ELECTRICAL SPECIFICATIONS**

$T_C = 25^\circ\text{C}$  unless otherwise specified

**Switching Characteristics (N-Channel, lower switches)**

CHARACTERISTICS	SYM.	MIN.	TYP.	MAX.	UNIT	TEST CONDITIONS
Turn-On Delay Time	$t_{d(ON)}$			25	ns	$V_M = 24\text{VDC}, I_M = 2\text{A}$
Rise Time	$t_r$			55	ns	$V_M = 24\text{VDC}, I_M = 2\text{A}$
Turn-Off Delay Time	$t_{d(OFF)}$			55	ns	$V_M = 24\text{VDC}, I_M = 2\text{A}$
Fall Time	$t_f$			45	ns	$V_M = 24\text{VDC}, I_M = 2\text{A}$
On-State Resistance	$R_{DS(ON)}$			0.20	ohms	$V_M = 24\text{VDC}, I_M = 2\text{A}$

**Switching Characteristics (P-Channel, upper switches)**

CHARACTERISTICS	SYM.	MIN.	TYP.	MAX.	UNIT	TEST CONDITIONS
Turn-On Delay Time	$t_{d(ON)}$			30	ns	$V_M = 24\text{VDC}, I_M = 2\text{A}$
Rise Time	$t_r$			50	ns	$V_M = 24\text{VDC}, I_M = 2\text{A}$
Turn-Off Delay Time	$t_{d(OFF)}$			70	ns	$V_M = 24\text{VDC}, I_M = 2\text{A}$
Fall Time	$t_f$			70	ns	$V_M = 24\text{VDC}, I_M = 2\text{A}$
On-State Resistance	$R_{DS(ON)}$			0.35	ohms	$V_M = 24\text{VDC}, I_M = 2\text{A}$

**Diode Characteristics**

CHARACTERISTICS	SYM.	MIN.	TYP.	MAX.	UNIT	TEST CONDITIONS
Forward Voltage	$V_F$			0.6	VDC	$V_M = 24\text{VDC}, I_M = 2\text{A}$
Forward Time	$t_f$			TBD	ns	$V_M = 24\text{VDC}, I_M = 2\text{A}$
Reverse Recovery Time	$t_{rr}$			TBD	ns	$V_M = 24\text{VDC}, I_M = 2\text{A}$

Micropac Industries cannot assume any responsibility for any circuits shown or represent that they are free from patent infringement.  
Micropac reserves the right to make changes at any time in order to improve design and to supply the best product possible.

High Side Input Specifications (Open Collector)

PARAMETERS	MIN	MAX	UNIT	TEST CONDITIONS
$V_{CE(OFF)}$	TBD	TBD	VDC	
$V_{CE(SAT)}$	TBD	TBD	VDC	@ $I_M = 2A$
Rise Time	TBD	TBD	ns	
Fall Time	TBD	TBD	ns	

Low Side Input Specifications

PARAMETERS	MIN	MAX	UNIT	TEST CONDITIONS
$V_{in} (Hi)$		15	VDC	
$V_{in} (Lo)$	0	0.5	VDC	
$I_{in} (Hi)$		300	mA	
$I_{in} (Lo)$		-300	mA	
Rise Time		TBD	ns	
Fall Time		TBD	ns	

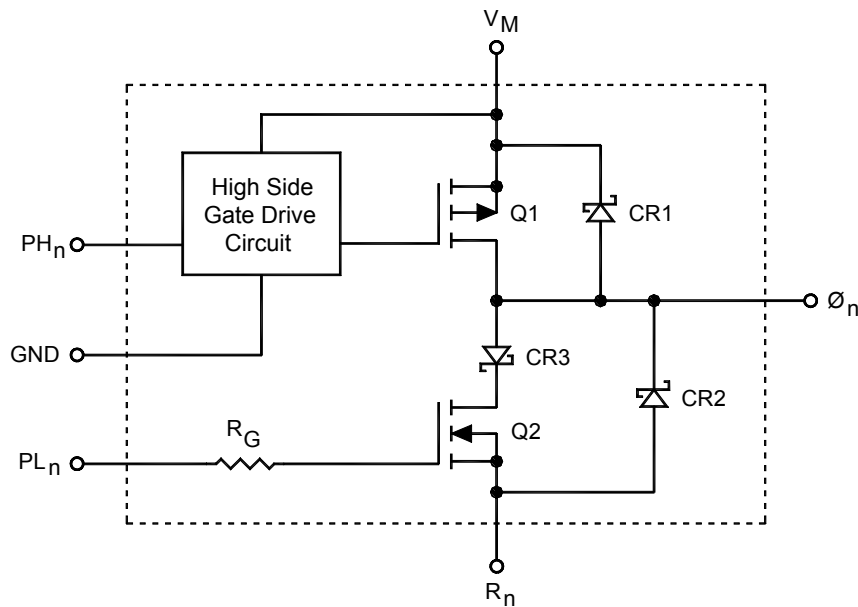

EQUIVALENT SCHEMATIC PER PHASE

Figure 1. Block Diagram

Micropac Industries cannot assume any responsibility for any circuits shown or represent that they are free from patent infringement. Micropac reserves the right to make changes at any time in order to improve design and to supply the best product possible.

Pin*	Symbol	Function
1	V <sub>M</sub>	Motor Bus Voltage
2	GND	GROUND
3	Ø <sub>A</sub>	OUTPUT, Phase A
4	Ø <sub>B</sub>	OUTPUT, Phase B
5	Ø <sub>C</sub>	OUTPUT, Phase C
6	PH <sub>A</sub>	INPUT, High Side, Phase A
7	PH <sub>B</sub>	INPUT, High Side, Phase B
8	PH <sub>C</sub>	INPUT, High Side, Phase C
9	PL <sub>A</sub>	INPUT, Low Side, Phase A
10	PL <sub>B</sub>	INPUT, Low Side, Phase B
11	PL <sub>C</sub>	INPUT, Low Side, Phase C
12	R <sub>A</sub>	Current Sense, Phase A
13	R <sub>B</sub>	Current Sense, Phase B
14	R <sub>C</sub>	Current Sense, Phase C
15	NC	Not Used
16	NC	Not Used
17	NC	Not Used
18	NC	Not Used

\*Tentative Pin assignment.

Figure 2. Pin Function

Micropac Industries cannot assume any responsibility for any circuits shown or represent that they are free from patent infringement. Micropac reserves the right to make changes at any time in order to improve design and to supply the best product possible.

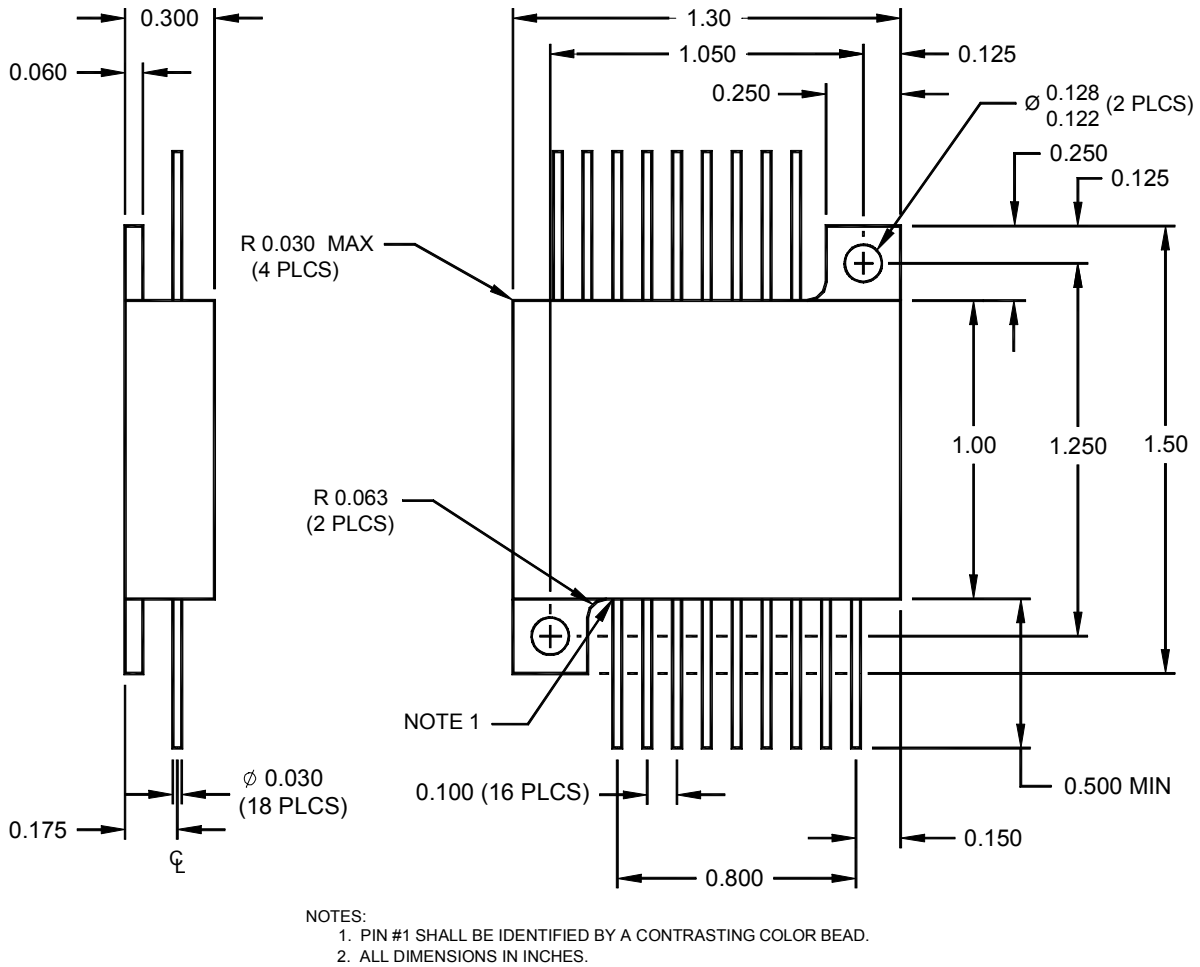

Figure 3. Case Outline

Micropac Industries cannot assume any responsibility for any circuits shown or represent that they are free from patent infringement.  
Micropac reserves the right to make changes at any time in order to improve design and to supply the best product possible.