

Hercules Encoders

Series 500

Hall Effect Incremental Rotary Shaft Encoders

- Enclosure: Low profile 3" L x 1.25" W x 2"
- NEMA 12/13 Dust-, Oil-tight
- Inherent Anti-Jitter Circuitry prevents false outputs due to machine vibration
- Low Supply Current Requirement — 15 milliamps typical per encoder, at 24Vdc
- Ideally suited for low PPR needs in dirty environments, wide temperature ranges

22

H
e
r
c
u
l
e
s



Specifications

Mechanical

Shaft Speed	4000 RPM maximum
Shaft Direction	Bidirectional
Standard Shaft Sizes (Dia.)	.2497", .3125"
Shaft Extension(s)	1.17" with .50x.05" flat
Mounting	Refer to dimensional drawings
Bearings	ABEC 7 Shielded
Radial Loading	15 lbs. Operating
Axial Loading	7 lbs. Operating
Accuracy	$\pm 1.0^\circ$ of Shaft Rotation Typical
Housing	Black Anodized Aluminum
Weight	7 oz.
Connector (Side)	Wire Out (Strip/Tin or Mate-n-Lok)

Electrical

Pulse Rate	10 kHz
Outputs	NPN w/ pullup; NPN open collector; PNP sourcing
Output Rating	
Open Collector Transistor	40 Vdc maximum
Supply Voltage	8 to 28 Vdc
	5 Vdc with 5V TTL output
Supply Current	15 mA maximum
Current Sinking	250 mA maximum
Output Duty Cycle	50/50 w/ $\pm 20\%$ typical tolerance
Rise/Fall Times	1 μ sec typical

Environmental

Operating Temp.	-20° to $+70^\circ$ C (-4° to $+158^\circ$ F)
Shock	20 g's for 11 Milliseconds
Vibration	5 to 1000 Hertz at 10 g's
Enclosures	NEMA 12/13 equiv. — Dust-, Oil-Tight

Electrical Connections

Function

Supply Voltage (-)	A
Supply Voltage (+)	B
Channel "A"	D
Channel "B"	E
Cable Shield	S

For the latest specifications visit our website
www.herculesencoders.com

Dimensional Drawings

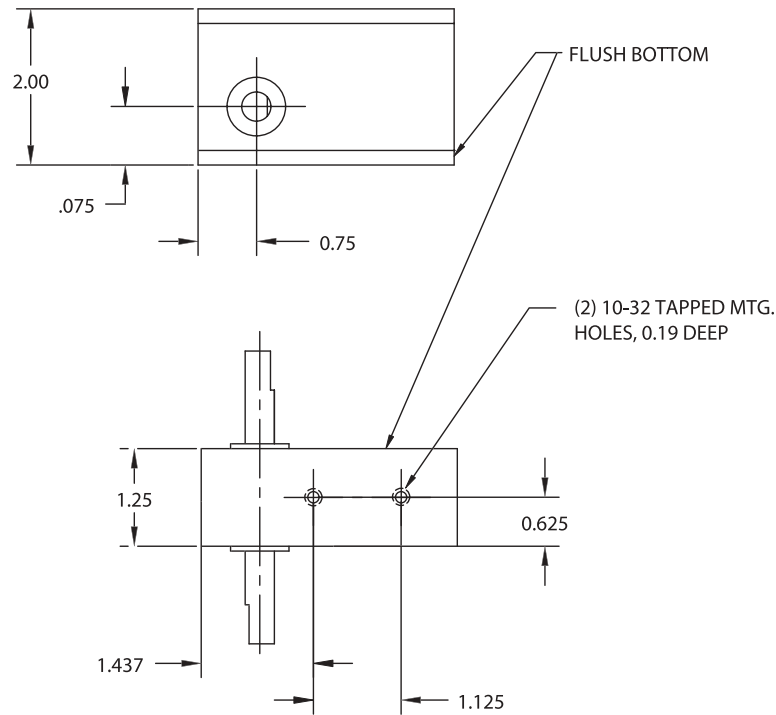
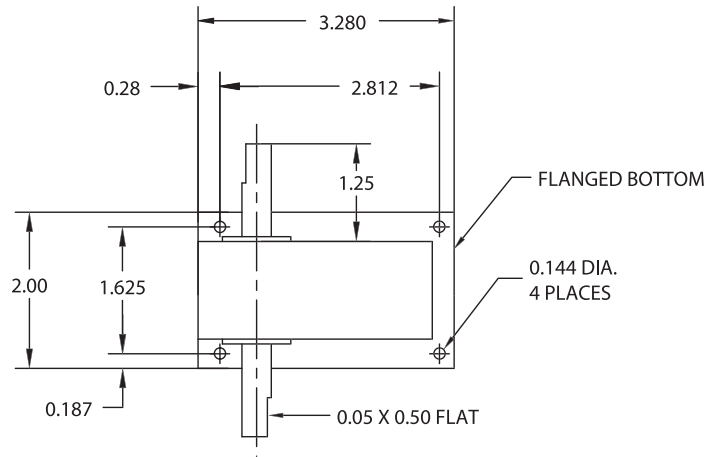

Ordering Information

Series 5 2 3

Shaft Diameter
 1=1/4" (0.2497")
 2=5/16" (0.3122")

Mounting Type
 1=10-32 BH on Base & Wire Leads
 2=Flanged Base & Wire Leads
 3=10-32 BH on Base & Male Connector
 4=Flanged Base & Male Connector

Channel Outputs A S 06

A=NPN w/Pullup Res.
 B=NPN Open Collector
 D=1.5K Pullup, No Ser. R
 F=5Vdc w/Pullup Res.
 G=5Vdc Open Collector
 H=PNP Sourcing Output

Channel Types
 S=Single Channel
 Q=Quadrature Outputs

PPR (Pulses per Revolution)

Channel Types "S" and "Q"

01	02	03	04
05	06	07	08
09	10	12	15
18	20	25	30

Added Channel Types "S" (Square Wave)

14	16	24
----	----	----