



High Efficiency Linear Power Supply with Power Surveillance and Time-out

Features

- Supply voltage monitoring
- Highly accurate 5 V, 100 mA guaranteed output
- Low dropout voltage, typically 380 mV at 100 mA
- Low quiescent current, typically 100 μ A
- Standby mode, maximum current 310 μ A (with 100 μ A load on OUTPUT)
- Unregulated DC input can withstand -20 V reverse battery and $+60$ V power transients
- Fully operational for unregulated DC input voltage up to 26 V and regulated output voltage down to 1 V
- Reset output guaranteed for regulated output voltage down to 1 V
- No reverse output current
- Very low temperature coefficient for the regulated output
- Current limiting
- Clear microprocessor restart after power up
- Push-pull or Open drain output
- -40 to $+85$ $^{\circ}$ C temperature range
- DIP8 and SO8 packages

Description

The A6300 offers a high level of integration by combining voltage regulation and voltage monitoring. The voltage regulator has a low dropout (typ. 380 mV at 100 mA) and a low quiescent current (100 μ A). The quiescent current increases only slightly in dropout prolonging battery life. Built-in protection includes a positive transient absorber for up to 60 V (load dump) and the ability to survive an unregulated input voltage of -20 V (reverse battery). The INPUT may be connected to ground or a reverse voltage without reverse current flow from the OUTPUT to the INPUT. Upon the OUTPUT voltage rising above V_{TH} , the reset output, whether RES or \overline{RES} , will remain active (RES = 1, \overline{RES} = 0) for an additional time of 50 ms. This allows the system voltage and the oscillator of the microprocessor to stabilize before they become fully active. When V_{OUTPUT} falls below V_{TH} , the reset output goes active. Threshold voltage can be obtained in different versions: 2 V, 2.4 V, 2.8 V, 3.5 V, 4 V.

Applications

- White / brown goods
- Industrial electronics
- Automotive electronics
- Cellular telephones
- Security systems
- Battery powered products
- High efficiency linear power supplies

Typical Operating Configuration

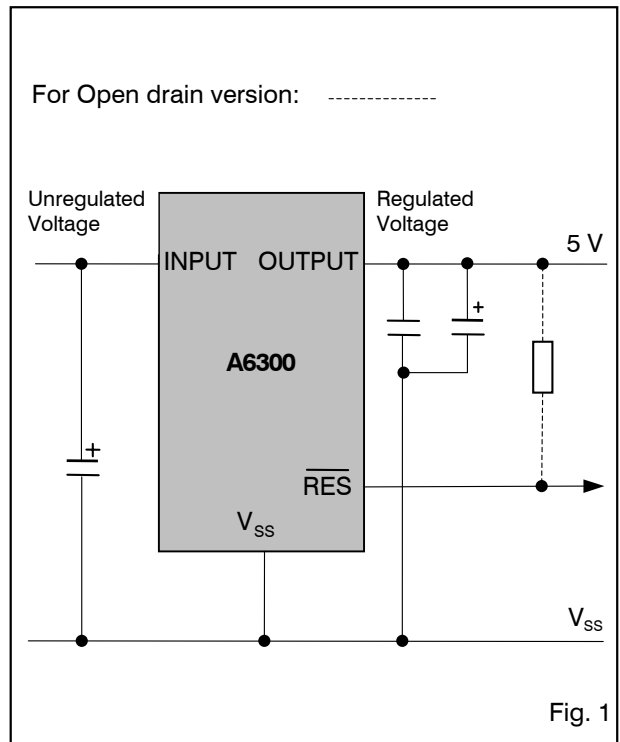

Pin Assignment

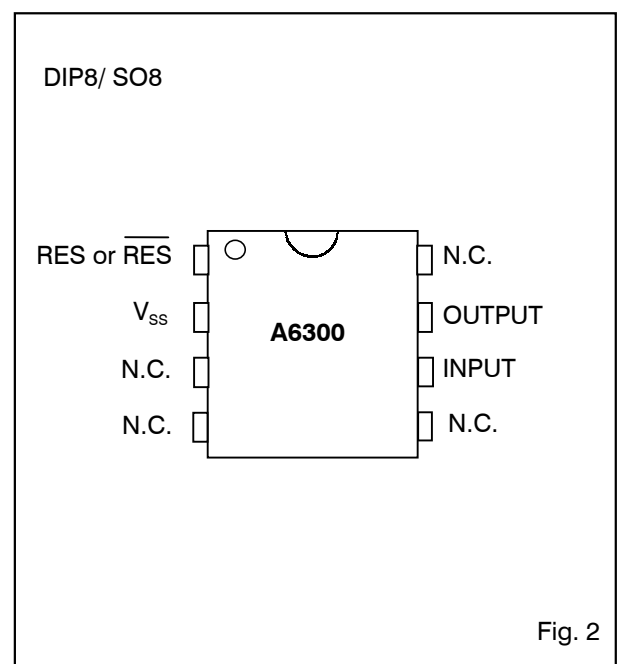

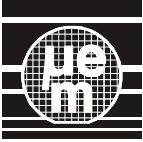

Absolute Maximum Ratings

Parameter	Symbol	Conditions
Continuous voltage at INPUT to V_{SS}	V_{INPUT}	- 0.3 to + 30 V
Transients on INPUT for $t < 100$ ms and duty cycle 1%	V_{TRANS}	up to + 60 V
Reverse supply voltage on INPUT	V_{REV}	- 20 V
Max. voltage at any signal pin	V_{MAX}	OUTPUT + 0.3 V
Min. voltage at any signal pin	V_{MIN}	$V_{SS} - 0.3$ V
Storage temperature	T_{STO}	- 65 to + 150 °C
Electrostatic discharge max. to MIL-STD-883C method 3015	V_{Smax}	1000 V
Max. soldering conditions	T_{Smax}	250 °C x 10 s

Table 1

Stresses above these listed maximum ratings may cause permanent damage to the device. Exposure beyond specified operating conditions may affect device reliability or cause malfunction.

Handling Procedures

This device has built-in protection against high static voltages or electric fields; however, anti-static precautions must be taken as for any other CMOS component. Unless otherwise specified, proper operation can only occur when all terminal voltages are kept within the supply voltage range. Unused inputs must always be tied to a defined logic voltage level.

Operating Conditions

Parameter	Symbol	Min.	Typ.	Max.	Units
Operating junction temperature ¹⁾	T_J	-40		+125	°C
INPUT voltage ²⁾	V_{INPUT}	2.3		26	V
OUTPUT voltage ²⁾³⁾	V_{OUTPUT}	1.0			V
Reset output guaranteed	V_{OUTPUT}	1.0			V
OUTPUT current ⁴⁾	I_{OUTPUT}			100	mA
Thermal resistance from junction to ambient ⁵⁾					
- DIP8	$R_{th(j-a)}$			105	°C/W
- SO8	$R_{th(j-a)}$			160	°C/W

Table 2

- ¹⁾ The maximum operating temperature is confirmed by sampling at initial device qualification. In production, all devices are tested at + 85 °C.
- ²⁾ Full operation guaranteed. To achieve the load regulation specified in Table 3 a 22 μ F capacitor or greater is required on the INPUT, see Fig. 6. The 22 μ F must have an effective resistance $\leq 5 \Omega$ and a resonant frequency above 500 kHz.
- ³⁾ A 10 μ F load capacitor and a 100 nF decoupling capacitor are required on the regulator OUTPUT for stability. The 10 μ F must have an effective series resistance of $\leq 5 \Omega$ and a resonant frequency above 500 kHz.
- ⁴⁾ The OUTPUT current will not apply for all possible combinations of input voltage and output current. Combinations that would require the A6300 to work above the maximum junction temperature (+125 °C) must be avoided.
- ⁵⁾ The thermal resistance specified assumes the package is soldered to a PCB.

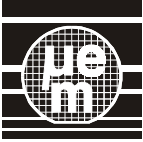

Electrical Characteristics

$V_{INPUT} = 6.0\text{ V}$, $C_L = 10\ \mu\text{F} + 100\ \text{nF}$, $C_{INPUT} = 22\ \mu\text{F}$, $T_J = -40\text{ to }+85\text{ }^\circ\text{C}$, unless otherwise specified

Parameter	Symbol	Test Conditions	Min.	Min. 25°C	Typ.	Max. 25°C	Max.	Unit
Supply current	I_{SS}	Reset output open, $I_L = 100\ \mu\text{A}$			100		310	μA
Supply current ¹⁾	I_{SS}	Reset output open, $I_L = 100\ \text{mA}$ at $V_{INPUT} = 8.0\ \text{V}$			1.7		4.2	mA
Output voltage	V_{OUTPUT}	$I_L = 100\ \mu\text{A}$	4.88				5.12	V
Output voltage	V_{OUTPUT}	$100\ \mu\text{A} \leq I_L \leq 100\ \text{mA}$, $-40\text{ }^\circ\text{C} \leq T_J \leq +125\text{ }^\circ\text{C}$	4.85				5.15	V
Output voltage temperature coefficient ²⁾	$V_{th(\text{coeff})}$				50		180	$\text{ppm}/^\circ\text{C}$
Line regulation ³⁾	V_{LINE}	$6\ \text{V} \leq V_{INPUT} \leq 26\ \text{V}$, $I_L = 1\ \text{mA}$, $T_J = +125\text{ }^\circ\text{C}$			0.2		0.5	%
Load regulation ³⁾	V_L	$100\ \mu\text{A} \leq I_L \leq 100\ \text{mA}$			0.2		0.6	%
Dropout voltage ⁴⁾	$V_{DROPOUT}$	$I_L = 100\ \mu\text{A}$			40		170	mV
Dropout voltage ⁴⁾	$V_{DROPOUT}$	$I_L = 100\ \text{mA}$			380			mV
Dropout voltage ⁴⁾	$V_{DROPOUT}$	$I_L = 100\ \text{mA}$, $-40\text{ }^\circ\text{C} \leq T_J \leq +125\text{ }^\circ\text{C}$					650	mV
Dropout supply current	I_{SS}	$V_{INPUT} = 4.5\ \text{V}$, $I_L = 100\ \mu\text{A}$ ⁸⁾			1.2		1.6	mA
Thermal regulation ⁵⁾	V_{thr}	$T_J = +25\text{ }^\circ\text{C}$, $I_L = 50\ \text{mA}$, $V_{INPUT} = 26\ \text{V}$, $T = 10\ \text{ms}$			0.05		0.25	$\%/^\circ\text{C}$
Current limit	I_{Lmax}	OUTPUT tied to V_{SS}			450			mA
OUTPUT noise, 10Hz to 100 kHz	V_{NOISE}				200			μVrms
Threshold voltage	V_{TH}	Version: AA, AG, AM	1.77	1.84	1.95	2.04	2.17	V
	V_{TH}	Version: AB, AH, AN	2.09	2.18	2.32	2.41	2.55	V
	V_{TH}	Version: AC, AI, AO	2.48	2.59	2.73	2.86	3.03	V
	V_{TH}	Version: AD, AJ, AP	3.11	3.23	3.42	3.59	3.80	V
	V_{TH}	Version: AE, AK, AQ	3.55	3.70	3.88	4.08	4.32	V
Threshold hysteresis	V_{HYS}				25			mV
RES Output Low Level	V_{OL}	$V_{OUTPUT} = 5\ \text{V}$, $I_{OL} = 8\ \text{mA}$			175		400	mV
	V_{OL}	$V_{OUTPUT} = 3\ \text{V}$, $I_{OL} = 4\ \text{mA}$			140		300	mV
	V_{OL}	$V_{OUTPUT} = 1\ \text{V}$, $I_{OL} = 50\ \mu\text{A}$			20		90	mV
RES Output High Level ⁷⁾	V_{OH}	$V_{OUTPUT} = 5\ \text{V}$, $I_{OH} = -8\ \text{mA}$	4.3		4.5			V
	V_{OH}	$V_{OUTPUT} = 3\ \text{V}$, $I_{OH} = -4\ \text{mA}$	2.3		2.6			V
	V_{OH}	$V_{OUTPUT} = 1\ \text{V}$, $I_{OH} = -100\ \mu\text{A}$	850		950			mV
Leakage current ⁶⁾	I_{LEAK}	$V_{OUTPUT} = 5\ \text{V}$			0.05		1	μA

Table 3

¹⁾ If INPUT is connected to V_{SS} , no reverse current will flow from the OUTPUT to the INPUT, however the supply current specified will be sunk by the OUTPUT to supply the A6300.

²⁾ The OUTPUT voltage temperature coefficient is defined as the worst case voltage change divided by the total temperature range.

³⁾ Regulation is measured at constant junction temperature using pulse testing with a low duty cycle. Changes in OUTPUT voltage due to heating effects are covered in the specification for thermal regulation.

⁴⁾ The dropout voltage is defined as the INPUT to OUTPUT differential, measured with the input voltage equal to 5.0 V.

⁵⁾ Thermal regulation is defined as the change in OUTPUT voltage at a time T after a change in power dissipation is applied, excluding load or line regulation effects.

⁶⁾ Only for open drain versions.

⁷⁾ For push-pull output only

⁸⁾ Reset output open



Timing Characteristics

$V_{\text{OUTPUT}} = 5.0 \text{ V}$, $C_L = 10 \mu\text{F} + 100 \text{ nF}$, $C_{\text{INPUT}} = 22 \mu\text{F}$, $T_J = -40 \text{ to } +85 \text{ }^\circ\text{C}$, unless otherwise specified

Parameter	Symbol	Test Conditions	Min.	Typ.	Max.	Units
Power-on Reset time	t_{POR}		25	50	75	ms
Sensitivity ¹⁾	t_{SEN}	$V_{\text{OUTPUT}} = 5 \text{ V to } 3 \text{ V in } 5 \mu\text{s}$	20	$0.8 \cdot t_{\text{R}}$		μs
Propagation time ¹⁾	t_{R}	$V_{\text{OUTPUT}} = 5 \text{ V to } 3 \text{ V in } 5 \mu\text{s}$	22	75	200	μs

¹⁾ Tested on version with V_{TH} higher than 3 V

Table 4

Timing Waveforms

Voltage Monitoring

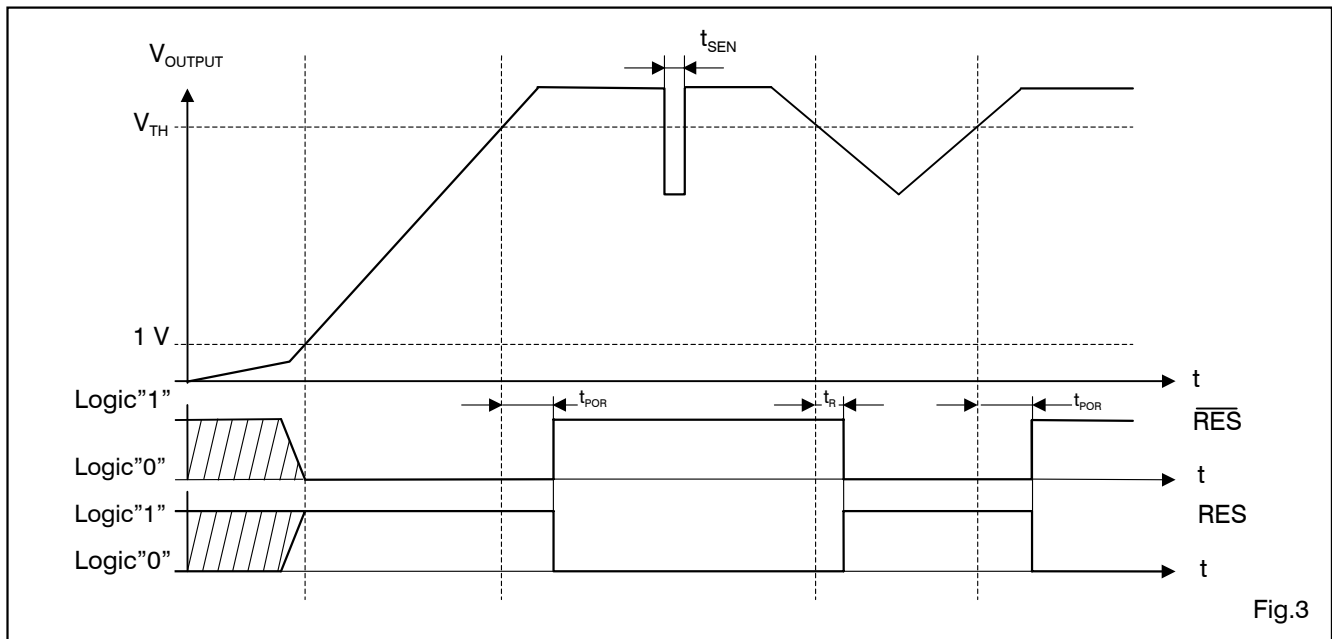

Fig.3

Block Diagram

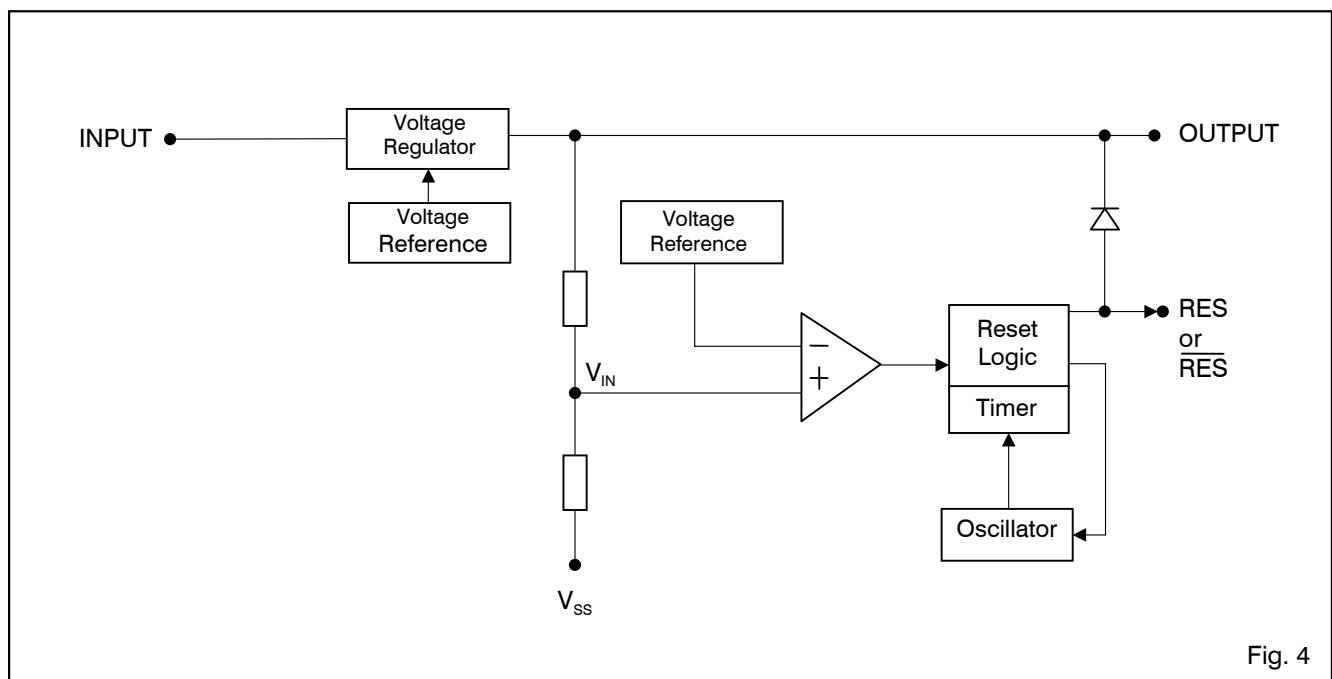
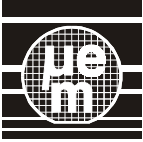

Fig. 4



Pin Description

Pin	Name	Function
1	RES or $\overline{\text{RES}}$	Reset output
2	V_{SS}	Supply ground
3	N.C.	Not connected
4	N.C.	Not connected
5	N.C.	Not connected
6	INPUT	Unregulated positive supply
7	OUTPUT	Regulated output
8	N.C.	Not connected

Table 5

Functional Description

Voltage Regulator

The A6300 has a $5\text{ V} \pm 2\%$, 100 mA, low dropout voltage regulator. The low supply current (typ. 100 μA) makes the A6300 particularly suited to automotive systems then remain energized 24 hours a day. The input voltage range is 2.3 V to 26 V for operation and the input protection includes both reverse battery (20 V below ground) and load dump (positive transients up to 60 V). There is no reverse current flow from the OUTPUT to the INPUT when the INPUT equals V_{SS} . This feature is important for systems which need to implement (with capacitance) a minimum power supply hold-up time in the event of power failure. To achieve good load regulation a 22 μF capacitor (or greater) is needed on the INPUT (see Fig. 5). Tantalum or aluminium electrolytics are adequate for the 22 μF capacitor; film types will work but are relatively expensive. Many aluminium electrolytics have electrolytes that freeze at about $-30\text{ }^\circ\text{C}$, so tantalums are recommended for operation below $-25\text{ }^\circ\text{C}$. The important parameters of the 22 μF capacitor are an effective series resistance of $\leq 5\ \Omega$ and a resonant frequency above 500 kHz.

A 10 μF capacitor (or greater) and a 100 nF capacitor are required on the OUTPUT to prevent oscillations due to instability. The specification of the 10 μF capacitor is as per the 22 μF capacitor on the INPUT (see previous paragraph).

The A6300 will remain stable and in regulation with no external load and the dropout voltage is typically constant as the input voltage fall to below its minimum level (see Table 2). These features are especially important in CMOS RAM keep-alive applications.

Voltage Monitoring

The power-on reset and the power-down reset are generated internally with a voltage comparison of the voltage reference and the resistor divider (see Fig. 4).

At power-up the reset output ($\overline{\text{RES}}$) is held low (see Fig. 3). After OUTPUT reaches V_{TH} , the $\overline{\text{RES}}$ output is held low for an additional power-on-reset (POR) delay t_{POR} (typically 50 ms). The power-on reset delay prevents repeated toggling of $\overline{\text{RES}}$ even if V_{OUTPUT} and the INPUT voltage drops out and recovers. The POR delay allows the microprocessor's crystal oscillator time to stabilize and to ensure correct recognition of the reset signal to the microprocessor.

The $\overline{\text{RES}}$ output goes active low generating the power-down reset whenever V_{OUTPUT} falls below V_{TH} . The sensitivity or reaction time of the internal comparator to the voltage level on V_{IN} is typically 70 μs .

Temperature Consideration

Care must be taken not to exceed the maximum junction temperature ($+125\text{ }^\circ\text{C}$). The power dissipation within the A6300 is given by the formula:

$$T_{\text{TOTAL}} = (V_{\text{INPUT}} - V_{\text{OUTPUT}}) * I_{\text{OUTPUT}} + (V_{\text{INPUT}}) * I_{\text{SS}}$$

The maximum continuous power dissipation at a given temperature can be calculated using the formula:

$$P_{\text{max}} = (125\text{ }^\circ\text{C} - T_{\text{A}}) / R_{\text{th(j-a)}}$$

where $R_{\text{th(j-a)}}$ is the thermal resistance from the junction to the ambient and is specified in Table 2. Note the $R_{\text{th(j-a)}}$ given in Table 2 assumes that the package is soldered to a PCB. The above formula for maximum power dissipation assumes a constant load (i.e. $\geq 100\text{ s}$). The transient thermal resistance for a single pulse is much lower than the continuous value. For example the A6300 in DIP8 package will have an effective thermal resistance from the junction to the ambient of about $10\text{ }^\circ\text{C/W}$ for a single 100 ms pulse.

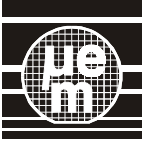

OUTPUT Current versus INPUT Voltage

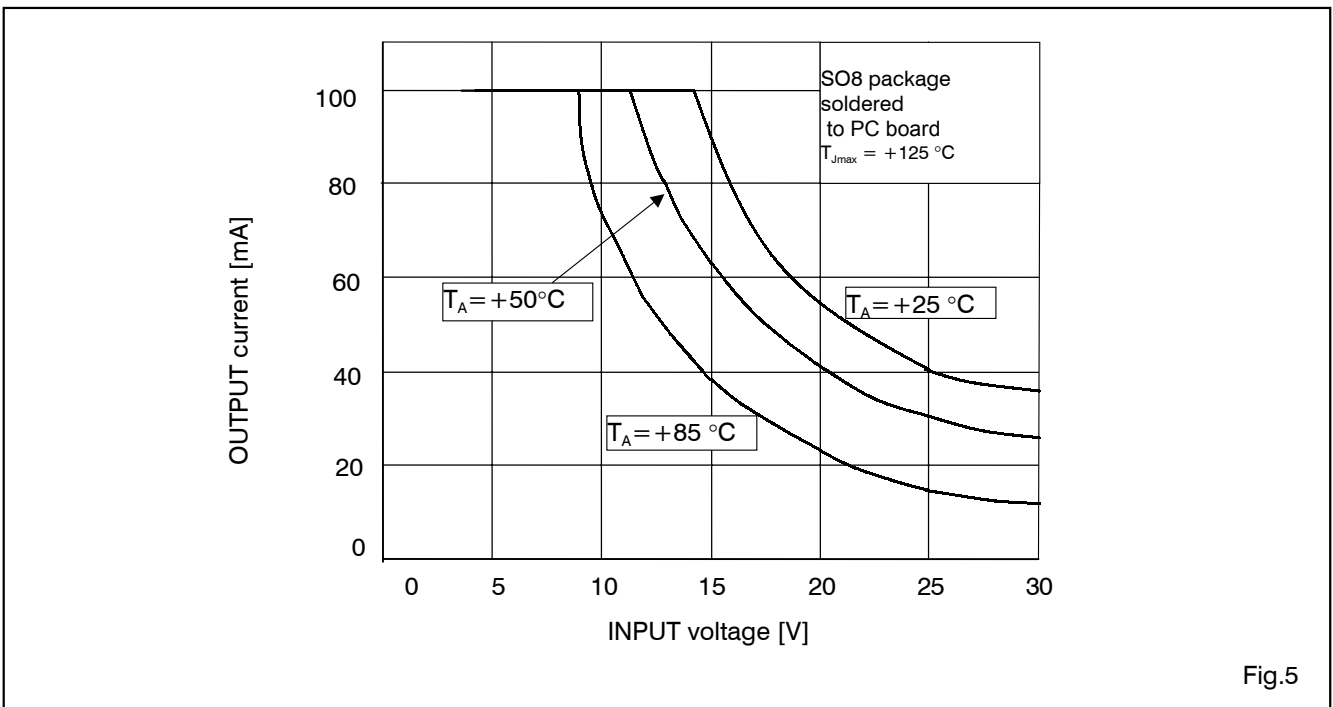

Fig.5

Typical Application

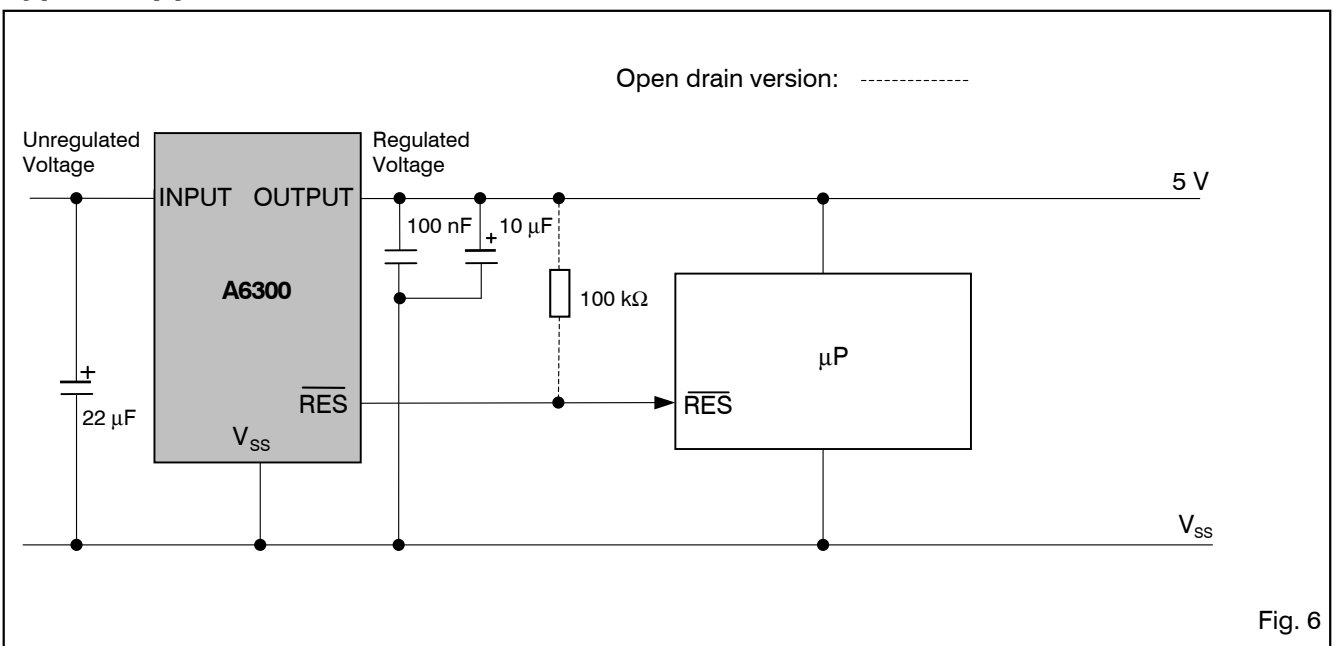
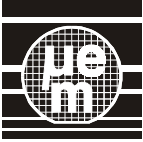
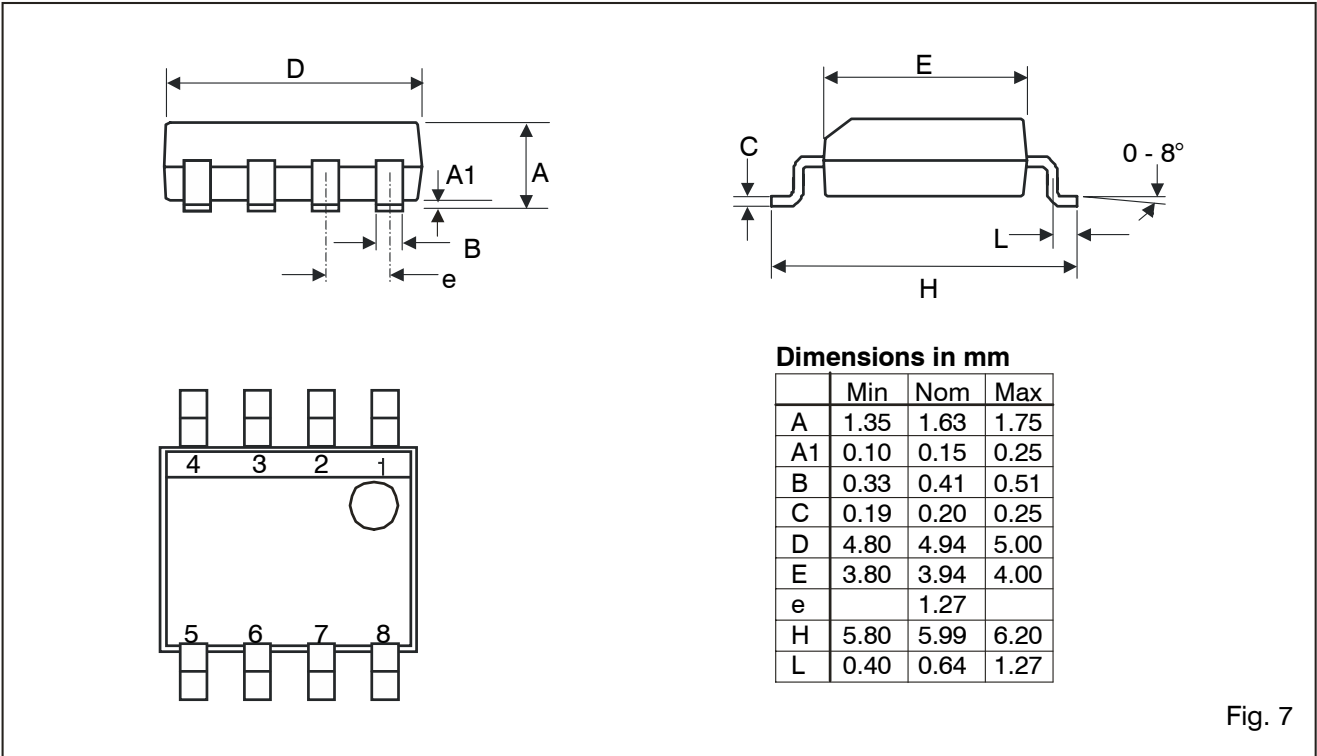

Fig. 6



Package Information

Dimensions of 8-Pin SOIC Package



Dimensions of 8-Pin Plastic DIP Package

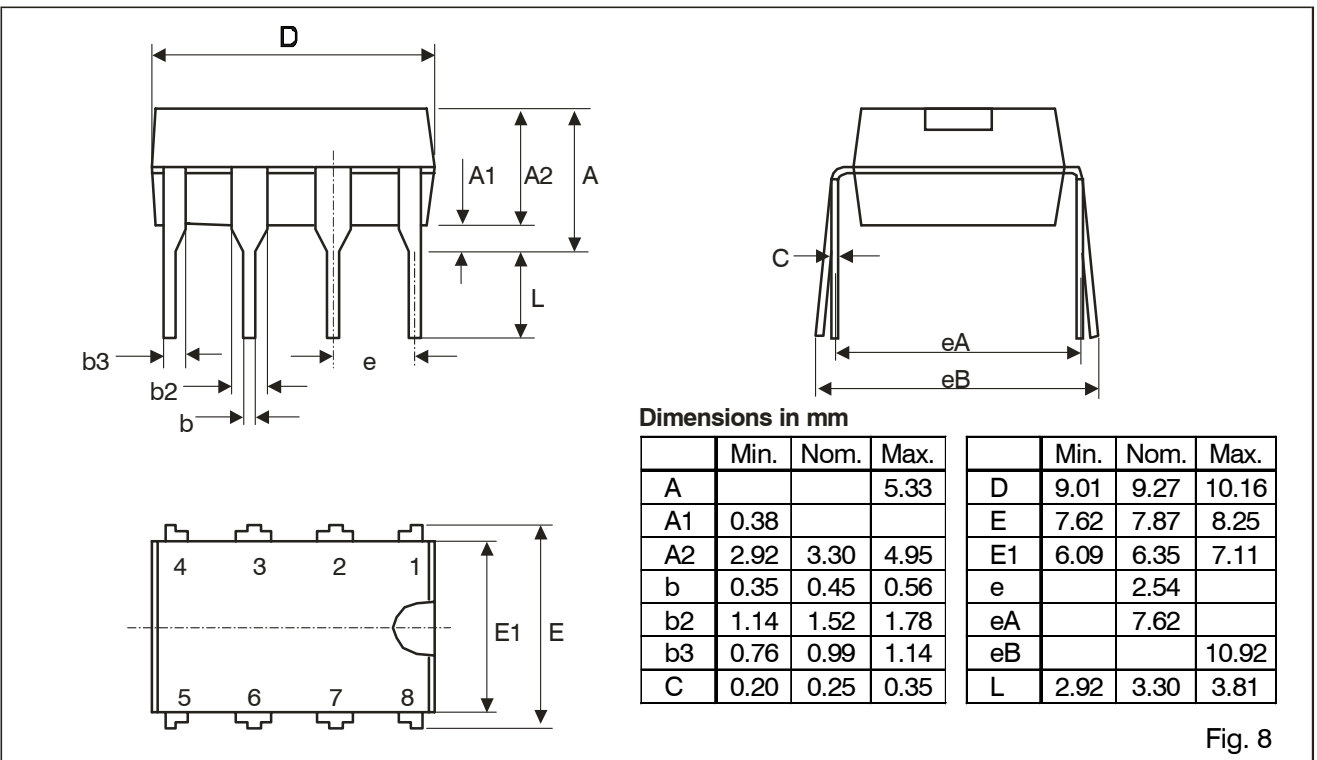

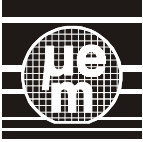

A6300

Ordering Information

Part Number: A6300 AQ SO8A

Threshold Voltage & Output Type

Package & Delivery Form

	2.0V	2.4V	2.8V	3.5V	4.0V
Push-pull, Reset active low	AA*	AB*	AC*	AD*	AE*
Push-pull, Reset active high	AG*	AH*	AI*	AJ*	AK*
Open drain, Reset active low	AM*	AN*	AO*	AP	AQ

Table 6

*= non stock item. Might be available on request and upon minimum order quantity (please contact EM Microelectronic).

SO8B = 8-pin SOIC, Tape & Reel
 SO8A = 8-pin SOIC, Stick
 DL8A = 8-pin plastic DIP, Stick

When ordering, please specify the complete Part Number without space between letters: e.g. A6300AQSO8A, A6300APSO8B, etc

Part Number	Package Marking (first line)
A6300%%SO8A	6300%%
A6300%%SO8B	6300%%
A6300%%DL8A	6300%%

Where %% refers to the 2 letters for the threshold voltage in Table 6 (AP, AQ, etc.)..

EM Microelectronic-Marin SA cannot assume any responsibility for use of any circuitry described other than entirely embodied in an EM Microelectronic-Marin SA product. EM Microelectronic-Marin SA reserves the right to change the circuitry and specifications without notice at any time. You are strongly urged to ensure that the information given has not been superseded by a more up-to-date version.

© 2002 EM Microelectronic-Marin SA, 03/02, Rev. F/465