

# Am29BDS643D

64 Megabit (4 M x 16-Bit)

CMOS 1.8 Volt-only Simultaneous Read/Write, Burst Mode Flash Memory

## DISTINCTIVE CHARACTERISTICS

- **Single 1.8 volt read, program and erase (1.7 to 1.9 volt)**
- **Multiplexed Data and Address for reduced I/O count**
  - A0–A15 multiplexed as D0–D15
  - Addresses are latched with AVD# control inputs while CE# low
- **Simultaneous Read/Write operation**
  - Data can be continuously read from one bank while executing erase/program functions in other bank
  - Zero latency between read and write operations
- **Read access times at 54 MHz/40 MHz**
  - Burst access times of 13.5/20 ns @ 30 pF at industrial temperature range
  - Asynchronous random access times of 90/90 ns @ 30 pF
  - Synchronous random access times of 106/120 ns @ 30 pF
- **Burst length**
  - Continuous linear burst
- **Power dissipation (typical values, 8 bits switching,  $C_L = 30$  pF)**
  - Burst Mode Read: 25 mA
  - Simultaneous Operation: 40 mA
  - Program/Erase: 15 mA
  - Standby mode: 0.2  $\mu$ A
- **Sector Architecture**
  - Eight 4 Kword sectors and one hundred twenty-seven 32 Kword sectors
  - Bank A contains the eight 4 Kword sectors and thirty-one 32 Kword sectors
  - Bank B contains ninety-six 32 Kword sectors
- **Sector Protection**
  - Software command sector locking
  - WP# protects the last two boot sectors
  - All sectors locked when  $V_{PP} = V_{IL}$
- **Handshaking feature**
  - Provides host system with minimum possible latency by monitoring RDY
- **Software command set compatible with JEDEC 42.4 standards**
  - Backwards compatible with Am29F and Am29LV families
- **Minimum 1 million erase cycle guarantee per sector**
- **20-year data retention at 125°C**
  - Reliable operation for the life of the system
- **Embedded Algorithms**
  - Embedded Erase algorithm automatically preprograms and erases the entire chip or any combination of designated sectors
  - Embedded Program algorithm automatically writes and verifies data at specified addresses
- **Data# Polling and toggle bits**
  - Provides a software method of detecting program and erase operation completion
- **Erase Suspend/Resume**
  - Suspends an erase operation to read data from, or program data to, a sector that is not being erased, then resumes the erase operation
- **Hardware reset input (RESET#)**
  - Hardware method to reset the device for reading array data
- **CMOS compatible inputs, CMOS compatible outputs**
- **Low  $V_{CC}$  write inhibit**
- **48-Ball FBGA package**

## GENERAL DESCRIPTION

The Am29BDS643 is a 64 Mbit, 1.8 Volt-only, simultaneous Read/Write, Burst Mode Flash memory device, organized as 4,194,304 words of 16 bits each. This device uses a single  $V_{CC}$  of 1.7 to 1.9 V to read, program, and erase the memory array. A 12.0-volt  $V_{PP}$  may be used for faster program performance if desired. The device can also be programmed in standard EPROM programmers.

At 40 MHz, the Am29BDS643 provides a burst access of 20 ns at 30 pF with initial access times of 120 ns at 30 pF. At 54 MHz, the Am29BDS643 provides a burst access of 13.5 ns at 30 pF with initial access times of 106 ns at 30 pF. The device operates within the industrial temperature range of  $-40^{\circ}\text{C}$  to  $+85^{\circ}\text{C}$ . The device is offered in the 48-ball FBGA package.

### Simultaneous Read/Write Operations with Zero Latency

The Simultaneous Read/Write architecture provides **simultaneous operation** by dividing the memory space into two banks. The device can improve overall system performance by allowing a host system to program or erase in one bank, then immediately and simultaneously read from the other bank, with zero latency. This releases the system from waiting for the completion of program or erase operations.

The device is divided as shown in the following table:

Bank A Sectors		Bank B Sectors	
Quantity	Size	Quantity	Size
8	4 Kwords	96	32 Kwords
31	32 Kwords		
16 Mbits total		48 Mbits total	

The device uses Chip Enable (CE#), Write Enable (WE#), Address Valid (AVD#) and Output Enable (OE#) to control asynchronous read and write opera-

tions. For burst operations, the device additionally requires Power Saving (PS), Ready (RDY), and Clock (CLK). This implementation allows easy interface with minimal glue logic to a wide range of microprocessors/microcontrollers for high performance read operations.

The device offers complete compatibility with the **JEDEC 42.4 single-power-supply Flash command set standard**. Commands are written to the command register using standard microprocessor write timings. Reading data out of the device is similar to reading from other Flash or EPROM devices.

The host system can detect whether a program or erase operation is complete by using the device **status bit** DQ7 (Data# Polling) and DQ6/DQ2 (toggle bits). After a program or erase cycle has been completed, the device automatically returns to reading array data.

The **sector erase architecture** allows memory sectors to be erased and reprogrammed without affecting the data contents of other sectors. The device is fully erased when shipped from the factory.

**Hardware data protection** measures include a low  $V_{CC}$  detector that automatically inhibits write operations during power transitions. The device also offers three types of data protection at the sector level. The **sector lock/unlock command sequence** disables or re-enables both program and erase operations in any sector. When at  $V_{IL}$ , **WP#** locks the two outermost sectors. Finally, when  $V_{PP}$  is at  $V_{IL}$ , all sectors are locked.

The device offers two power-saving features. When addresses have been stable for a specified amount of time, the device enters the **automatic sleep mode**. The system can also place the device into the **standby mode**. Power consumption is greatly reduced in both modes.

## TABLE OF CONTENTS

<b>Product Selector Guide</b> .....	<b>4</b>	Figure 3. Data# Polling Algorithm .....	23
<b>Block Diagram</b> .....	<b>4</b>	DQ6: Toggle Bit I .....	24
<b>Block Diagram of</b>		Figure 4. Toggle Bit Algorithm.....	24
<b>Simultaneous Operation Circuit</b> .....	<b>5</b>	DQ2: Toggle Bit II .....	25
<b>Connection Diagram</b> .....	<b>6</b>	Table 5. DQ6 and DQ2 Indications .....	25
Special Handling Instructions for FBGA Package .....	6	Reading Toggle Bits DQ6/DQ2 .....	25
<b>Input/Output Descriptions</b> .....	<b>7</b>	DQ5: Exceeded Timing Limits .....	25
<b>Logic Symbol</b> .....	<b>7</b>	DQ3: Sector Erase Timer .....	26
<b>Ordering Information</b> .....	<b>8</b>	Table 6. Write Operation Status .....	26
<b>Device Bus Operations</b> .....	<b>9</b>	<b>Absolute Maximum Ratings</b> .....	<b>27</b>
Table 1. Device Bus Operations .....	9	Figure 5. Maximum Negative Overshoot Waveform .....	27
Requirements for Asynchronous Read Operation (Non-Burst) .....	9	Figure 6. Maximum Positive Overshoot Waveform.....	27
Requirements for Synchronous (Burst) Read Operation .....	9	<b>Operating Ranges</b> .....	<b>27</b>
Programmable Wait State .....	10	<b>DC Characteristics</b> .....	<b>28</b>
Handshaking .....	10	<b>Test Conditions</b> .....	<b>29</b>
Power Saving Function .....	10	Figure 7. Test Setup.....	29
Simultaneous Read/Write Operations with Zero Latency .....	10	Table 7. Test Specifications .....	29
Writing Commands/Command Sequences .....	10	<b>Key to Switching Waveforms</b> .....	<b>29</b>
Accelerated Program Operation .....	11	<b>Switching Waveforms</b> .....	<b>29</b>
Autoselect Functions .....	11	Figure 8. Input Waveforms and Measurement Levels .....	29
Automatic Sleep Mode .....	11	<b>AC Characteristics</b> .....	<b>30</b>
RESET#: Hardware Reset Input .....	11	Synchronous/Burst Read .....	30
Output Disable Mode .....	11	Figure 9. Burst Mode Read (54 MHz) .....	30
Hardware Data Protection .....	12	Figure 10. Burst Mode Read (40 MHz) .....	31
Low VCC Write Inhibit .....	12	Asynchronous Read .....	32
Write Pulse “Glitch” Protection .....	12	Figure 11. Asynchronous Mode Read.....	32
Logical Inhibit .....	12	Figure 12. Reset Timings.....	33
Table 2. Sector Address Table .....	13	Erase/Program Operations .....	34
<b>Command Definitions</b> .....	<b>17</b>	Figure 13. Program Operation Timings.....	35
Reading Array Data .....	17	Figure 14. Chip/Sector Erase Operations .....	36
Set Wait State Command Sequence .....	17	Figure 15. Accelerated Unlock Bypass Programming Timing.....	37
Table 3. Third Cycle Address/Data .....	17	Figure 16. Data# Polling Timings (During Embedded Algorithm) ..	38
Handshaking .....	17	Figure 17. Toggle Bit Timings (During Embedded Algorithm).....	38
Enable PS (Power Saving) Mode Command Sequence .....	17	Figure 18. Latency with Boundary Crossing .....	39
Sector Lock/Unlock Command Sequence .....	17	Figure 19. Initial Access with Power Saving (PS)	
Reset Command .....	18	Function and Address Boundary Latency .....	40
Autoselect Command Sequence .....	18	Figure 20. Example of Five Wait States Insertion	
Program Command Sequence .....	18	(Non-Handshaking Device) .....	41
Unlock Bypass Command Sequence .....	18	Figure 21. Back-to-Back Read/Write Cycle Timings .....	42
Figure 1. Program Operation .....	19	<b>Erase and Programming Performance</b> .....	<b>43</b>
Chip Erase Command Sequence .....	19	<b>Data Retention</b> .....	<b>43</b>
Sector Erase Command Sequence .....	20	<b>Physical Dimensions*</b> .....	<b>44</b>
Erase Suspend/Erase Resume Commands .....	20	FDE048—48-Pin Fine-Pitch Ball Grid Array (FBGA)	
Figure 2. Erase Operation.....	21	11 x 10 mm package .....	44
Command Definitions .....	22	<b>Revision Summary</b> .....	<b>46</b>
Table 4. Command Definitions .....	22	Revision A (June 20, 2000) .....	46
<b>Write Operation Status</b> .....	<b>23</b>	Revision A+1 (November 27, 2000) .....	46
DQ7: Data# Polling .....	23	Revision A+2 (November 30, 2000) .....	46
		Revision A+3 (December 21, 2000) .....	46

PRODUCT SELECTOR GUIDE

Part Number	Am29BDS643D				
	Synchronous/Burst			Asynchronous	
	Speed Option	9A (40 MHz)	9B (54 MHz)	Speed Option	9A, 9B
$V_{CC} = 1.7 - 1.9 V$	Max Initial Access Time, ns ( $t_{iACC}$ )	120	106	Max Access Time, ns ( $t_{ACC}$ )	90
	Max Burst Access Time, ns ( $t_{BACC}$ )	20	13.5	Max CE# Access, ns ( $t_{CE}$ )	90
	Max OE# Access, ns ( $t_{OE}$ )	20	20	Max OE# Access, ns ( $t_{OE}$ )	35

BLOCK DIAGRAM

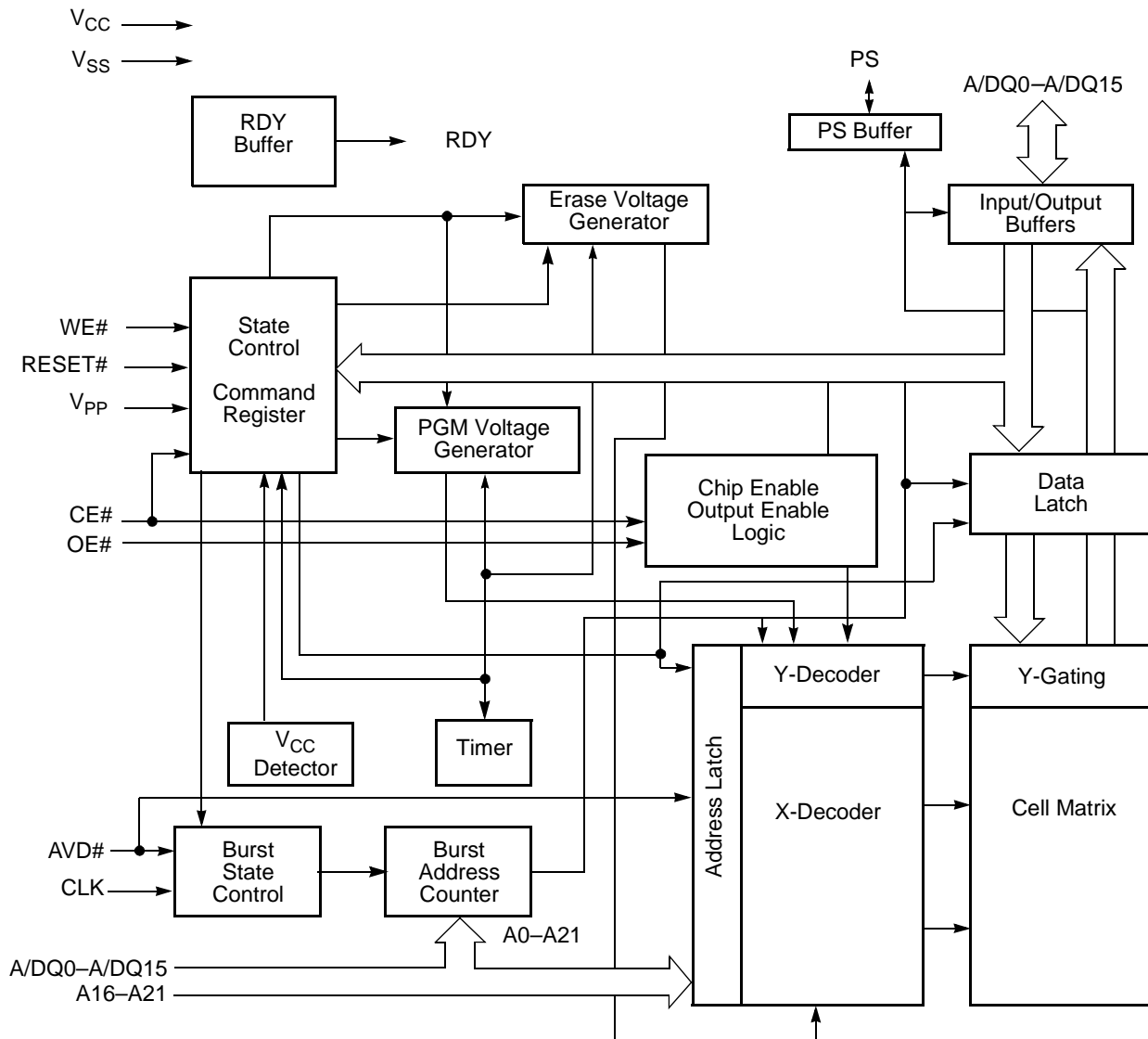

# BLOCK DIAGRAM OF SIMULTANEOUS OPERATION CIRCUIT

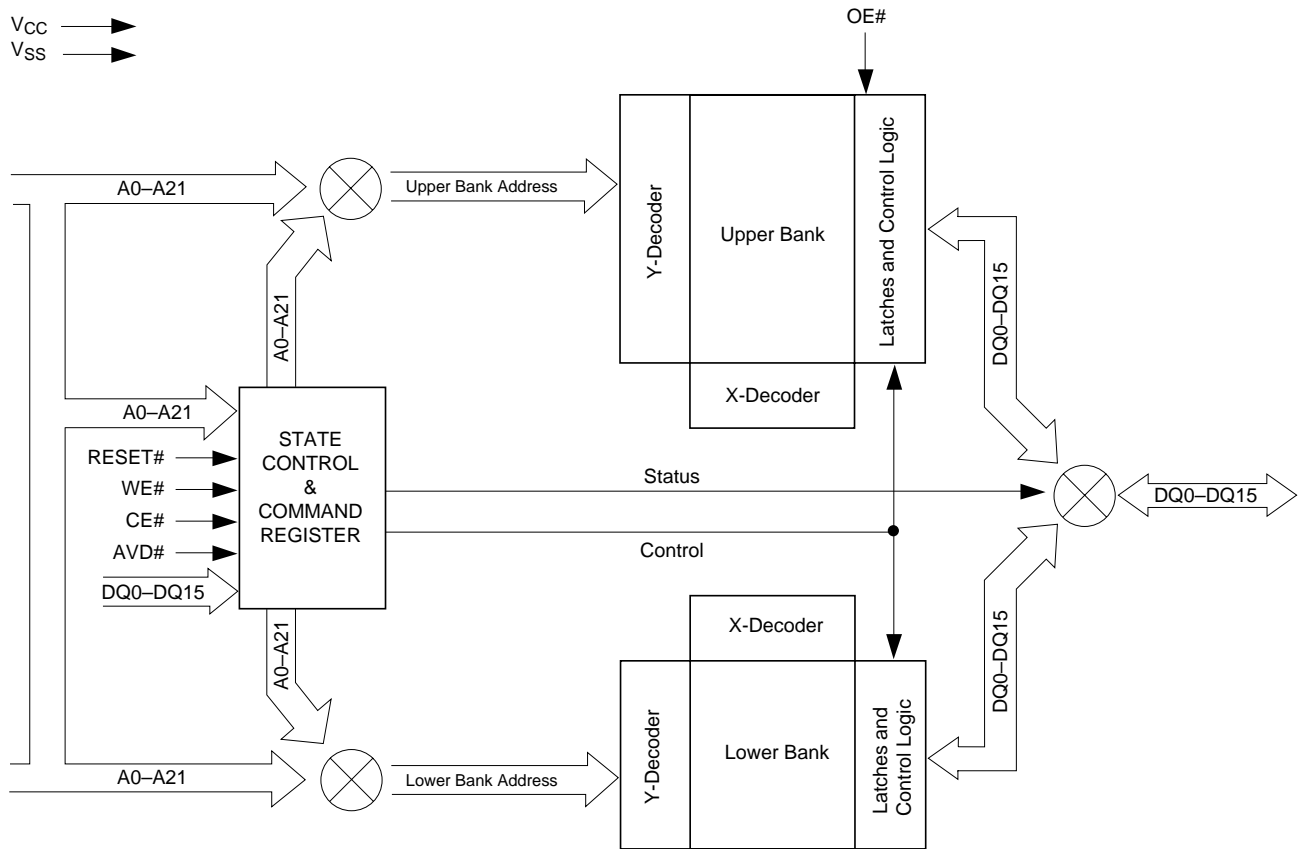

**Note:** A0-A15 are multiplexed with DQ0-DQ15.

CONNECTION DIAGRAM

48-Ball FBGA  
Top View, Balls Facing Down

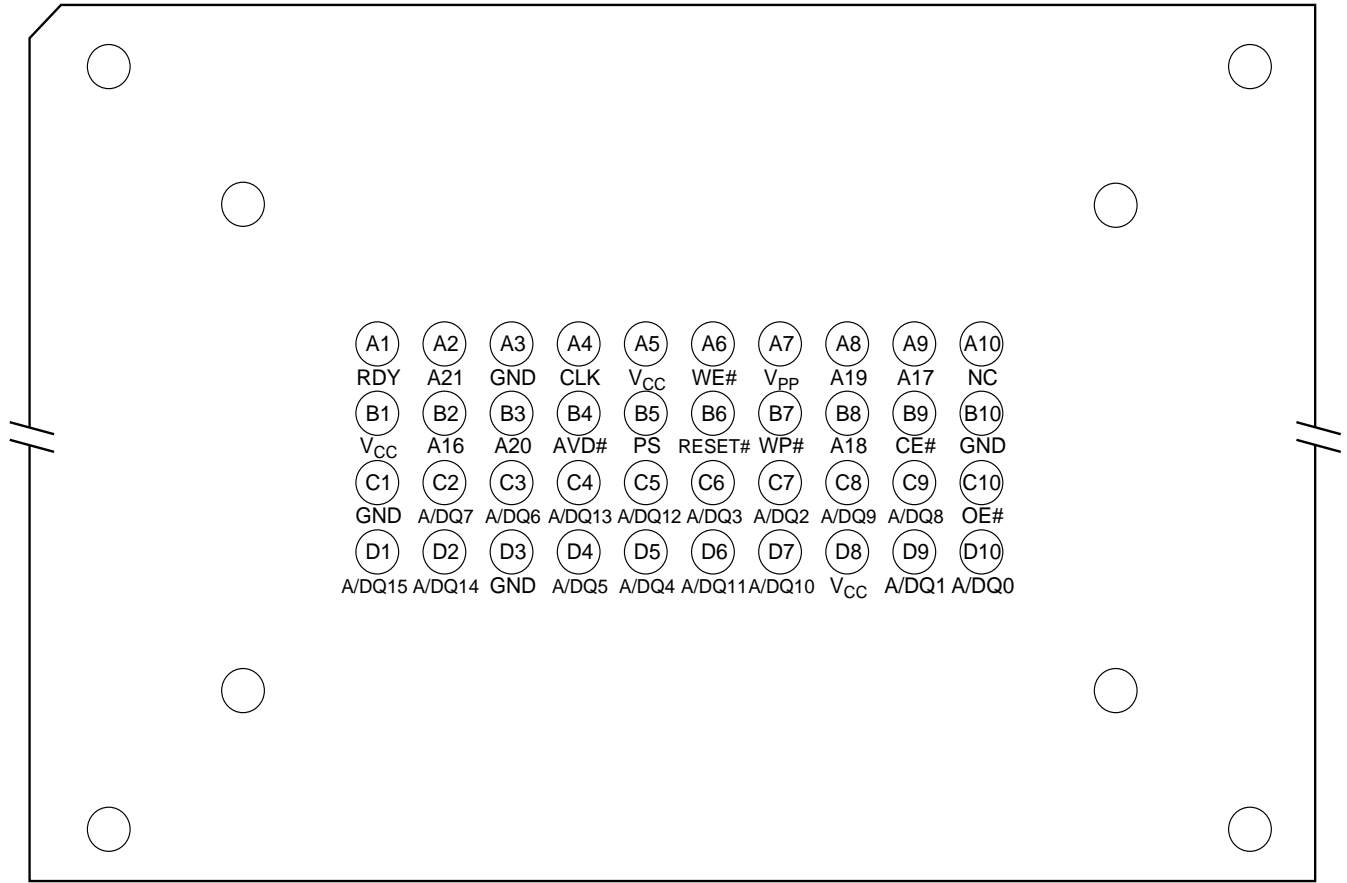

**Special Handling Instructions for FBGA Package**

Special handling is required for Flash Memory products in FBGA packages.

Flash memory devices in FBGA packages may be damaged if exposed to ultrasonic cleaning methods. The package and/or data integrity may be compromised if the package body is exposed to temperatures above 150°C for prolonged periods of time.

## INPUT/OUTPUT DESCRIPTIONS

- A16–A21 = Address Inputs
- A/DQ0–A/DQ15 = Multiplexed Address/Data input/output
- CE# = Chip Enable Input. Asynchronous relative to CLK for the Burst mode.
- OE# = Output Enable Input. Asynchronous relative to CLK for the Burst mode.
- WE# = Write Enable Input.
- V<sub>CC</sub> = Device Power Supply (1.7 V–1.9 V).
- V<sub>SS</sub> = Ground
- NC = No Connect; not connected internally
- RDY = Ready output; indicates the status of the Burst read. Low = data not valid at expected time. High = data valid.
- CLK = The first rising edge of CLK in conjunction with AVD# low latches address input and activates burst mode operation. After the initial word is output, subsequent rising edges of CLK increment the internal address counter. CLK should remain low during asynchronous access.
- AVD# = Address Valid input. Indicates to device that the valid address is present on the address inputs (address bits A0–A15 are multiplexed, address bits A16–A21 are address only).  
  
Low = for asynchronous mode, indicates valid address; for burst mode, causes starting address to be latched on rising edge of CLK.  
High = device ignores address inputs

- PS = Power Saving input/output  
  
During a read operation, PS indicates whether or not the data on the outputs are inverted. Low = data not inverted; High = data inverted
- RESET# = Hardware reset input. Low = device resets and returns to reading array data
- WP# = Hardware write protect input. Low = disables writes to SA133 and SA134
- V<sub>PP</sub> = At 12 V, accelerates programming; automatically places device in unlock bypass mode. At V<sub>IL</sub>, disables program and erase functions. Should be at V<sub>IH</sub> for all other conditions.

## LOGIC SYMBOL

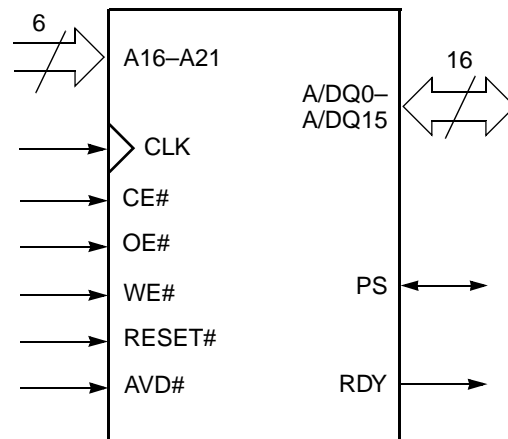

**ORDERING INFORMATION**

The order number (Valid Combination) is formed by the following:

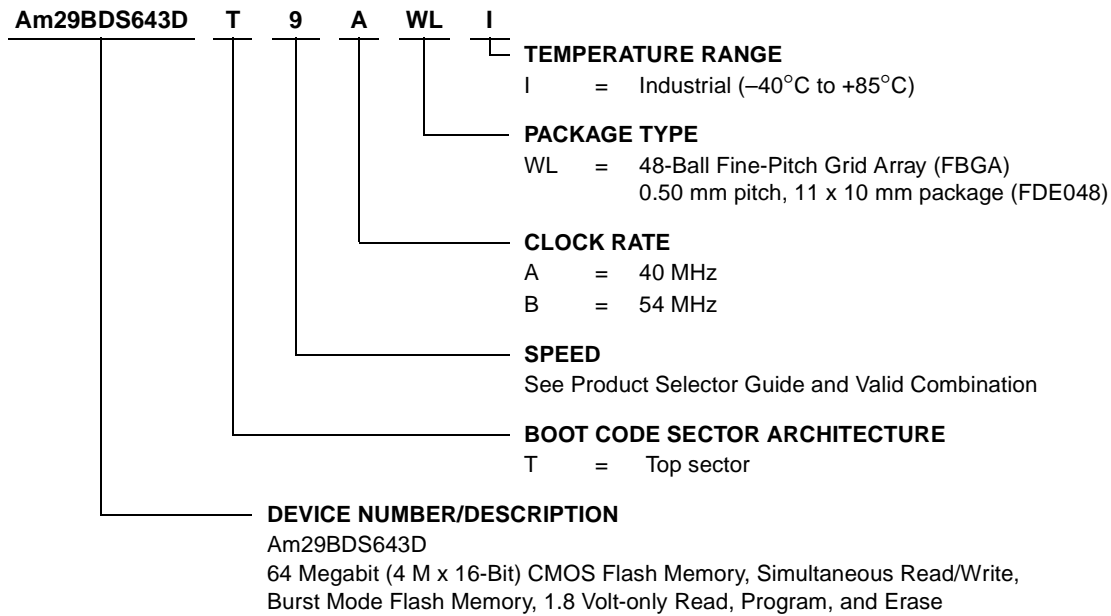

**Valid Combinations**

Valid Combination configuration planned to be supported for this device.

Valid Combinations	
Order Number	Package Marking
Am29BDS643DT9AWLI	N643DTH9AVI
Am29BDS643DT9BWL I	N643DTH9BVI











## DEVICE BUS OPERATIONS

This section describes the requirements and use of the device bus operations, which are initiated through the internal command register. The command register itself does not occupy any addressable memory location. The register is composed of latches that store the commands, along with the address and data information needed to execute the command. The contents of

the register serve as inputs to the internal state machine. The state machine outputs dictate the function of the device. Table 1 lists the device bus operations, the inputs and control levels they require, and the resulting output. The following subsections describe each of these operations in further detail.

**Table 1. Device Bus Operations**

Operation	CE#	OE#	WE#	A16–21	A/DQ0–15	RESET#	CLK	AVD#
Asynchronous Read	L	L	H	Addr In	I/O	H	L	
Write	L	H	L	Addr In	I/O	H	L	
Standby (CE#)	H	X	X	HIGH Z	HIGH Z	H	X	X
Hardware Reset	X	X	X	HIGH Z	HIGH Z	L	X	X
<b>Burst Read Operations</b>								
Load Starting Burst Address	L	H	H	Addr In	Addr In	H		
Advance Burst to next address with appropriate Data presented on the Data Bus	L	L	H	HIGH Z	Burst Data Out	H		H
Terminate current Burst read cycle	H	X	H	HIGH Z	HIGH Z	H		X
Terminate current Burst read cycle via RESET#	X	X	H	HIGH Z	HIGH Z	L	X	X
Terminate current Burst read cycle and start new Burst read cycle	L	H	H	HIGH Z	I/O	H		

**Legend:** L = Logic 0, H = Logic 1, X = Don't Care.

### Requirements for Asynchronous Read Operation (Non-Burst)

To read data from the memory array, the system must first assert a valid address on A/DQ0–A/DQ15 and A16–A21, while driving AVD# and CE# to  $V_{IL}$ . WE# should remain at  $V_{IH}$ . Note that CLK must remain low for asynchronous read operations. The rising edge of AVD# latches the address, after which the system can drive OE# to  $V_{IL}$ . The data will appear on A/DQ0–A/DQ15. Since the memory array is divided into two banks, each bank remains enabled for read access until the command register contents are altered.

Address access time ( $t_{ACC}$ ) is equal to the delay from stable addresses to valid output data. The chip enable access time ( $t_{CE}$ ) is the delay from the stable addresses and stable CE# to valid data at the outputs. The output enable access time ( $t_{OE}$ ) is the delay from the falling edge of OE# to valid data at the output.

The internal state machine is set for reading array data upon device power-up, or after a hardware reset. This

ensures that no spurious alteration of the memory content occurs during the power transition.

### Requirements for Synchronous (Burst) Read Operation

The device is capable of continuous, sequential (linear) burst operation. However, when the device first powers up, it is enabled for asynchronous read operation. The device will automatically be enabled for burst mode on the first rising edge on the CLK input, while AVD# is held low for one clock cycle. Prior to activating the clock signal, the system should determine how many wait states are desired for the initial word ( $t_{IACC}$ ) of each burst session. The system would then write the Set Wait Count command sequence (see “Programmable Wait State”). The system may optionally activate the PS mode (see “Power Saving Function”) by writing the Enable PS Mode command sequence at this time, but note that the PS mode can only be disabled by a hardware reset. (See “Command Definitions” for further details).

The initial word is output  $t_{IACC}$  after the rising edge of the first CLK cycle. Subsequent words are output  $t_{BACC}$

after the rising edge of each successive clock cycle, which automatically increments the internal address counter. **Note that the device has a fixed internal address boundary that occurs every 64 words, starting at address 00003Eh. The transition from the highest address 3FFFFFFh to 000000h is also a boundary crossing.** During the time the device is outputting the 64th word (address 00003Eh, 00007Eh, 0000BEh, etc.), a two cycle latency occurs before data appears for the next address (address 00003Fh, 00007Fh, 0000BFh, etc.). The RDY output indicates this condition to the system by pulsing low. See Figures 18 and 19.

The device will continue to output sequential burst data, wrapping around to address 000000h after it reaches the highest addressable memory location, until the system asserts CE# high, RESET# low, or AVD# low in conjunction with a new address. See Table 1. The reset command does *not* terminate the burst read operation.

If the host system crosses the bank boundary while reading in burst mode, and the device is not programming or erasing, a two-cycle latency will occur as described above. If the host system crosses the bank boundary while the device is programming or erasing, the device will provide asynchronous read status information. The clock will be ignored. After the host has completed status reads, or the device has completed the program or erase operation, the host can restart a burst operation using a new address and AVD# pulse.

If the clock frequency is less than 6 MHz during a burst mode operation, additional latencies will occur. RDY indicates the length of the latency by pulsing low.

### Programmable Wait State

The programmable wait state feature indicates to the device the number of additional clock cycles that must elapse after AVD# is driven active before data will be available. Upon power up, the device defaults to the maximum of seven total cycles. The total number of wait states is programmable from four to seven cycles. See Figure 20.

### Handshaking

The handshaking feature allows the host system to simply monitor the RDY signal from the device to determine when the initial word of burst data is ready to be read. The host system should use the wait state command sequence to set the number of wait states for optimal burst mode operation (00h for 40 MHz clock and 01h for 54 MHz clock. The initial word of burst data is indicated by the rising edge of RDY after OE# goes low.

The presence of the handshaking feature may be verified by writing the autoselect command sequence to the device. See “Autoselect Command Sequence” for details.

### Power Saving Function

The Power Save function reduces the amount of switching on the data output bus by changing the minimum number of bits possible, thereby reducing power consumption. This function is active only during burst mode operations.

The device compares the word previously output to the system with the new word to be output. If the number of bits to be switched is 0–8 (less than half the bus width), the device simply outputs the new word on the data bus. If, however, the number of bits that must be switched is 9 or higher, the data is *inverted* before being output on the data bus. This effectively limits the maximum number of bits that are switched for any given read cycle to eight. The device indicates to the system whether or not the data is inverted via the PS (power saving) output. If the word on the data bus is *not* inverted,  $PS = V_{IL}$ ; if the word on the data bus is inverted,  $PS = V_{IH}$ .

During initial power up the PS function is disabled. To enable the PS function, the system must write the Enable PS command sequence to the flash device (see the Command Definitions table).

When the PS function is enabled, one additional clock cycle is inserted during the initial and second access of a burst sequence. See Figure 19. The RDY output indicates this condition to the system.

The device is also capable of receiving inverted data during program operations. The host system must indicate to the device via the PS input whether or not the program data is inverted. PS must be driven to  $V_{IH}$  for inverted data, or to  $V_{IL}$  for non-inverted data.

To disable the PS function, the system must hardware reset the device (drive the RESET# input low).

### Simultaneous Read/Write Operations with Zero Latency

This device is capable of reading data from one bank of memory while programming or erasing in the other bank of memory. An erase operation may also be suspended to read from or program to another location within the same bank (except the sector being erased). Figure 21 shows how read and write cycles may be initiated for simultaneous operation with zero latency. Refer to the DC Characteristics table for read-while-program and read-while-erase current specifications.

### Writing Commands/Command Sequences

The device has inputs/outputs that accept both address and data information. To write a command or command sequence (which includes programming data to the device and erasing sectors of memory), the system must drive CLK, AVD# and CE# to  $V_{IL}$ , and OE# to  $V_{IH}$  when providing an address to the device,

and drive CLK, WE# and CE# to  $V_{IL}$ , and OE# to  $V_{IH}$  when writing commands or data.

The device features an **Unlock Bypass** mode to facilitate faster programming. Once the device enters the Unlock Bypass mode, only two write cycles are required to program a word, instead of four.

An erase operation can erase one sector, multiple sectors, or the entire device. Table 2 indicates the address space that each sector occupies. The device address space is divided into two banks: Bank A contains the boot/parameter sectors, and Bank B contains the larger, code sectors of uniform size. A “bank address” is the address bits required to uniquely select a bank. Similarly, a “sector address” is the address bits required to uniquely select a sector.

$I_{CC2}$  in the DC Characteristics table represents the active current specification for the write mode. The AC Characteristics section contains timing specification tables and timing diagrams for write operations.

### Accelerated Program Operation

The device offers accelerated program operations through the  $V_{PP}$  input. This function is primarily intended to allow faster manufacturing throughput at the factory. If the system asserts  $V_{ID}$  on this input, the device automatically enters the aforementioned Unlock Bypass mode, temporarily unprotects any protected sectors, and uses the higher voltage on the input to reduce the time required for program operations. The system would use a two-cycle program command sequence as required by the Unlock Bypass mode. Removing  $V_{ID}$  from the  $V_{PP}$  input returns the device to normal operation.

### Autoselect Functions

If the system writes the autoselect command sequence, the device enters the autoselect mode. The system can then read autoselect codes from the internal register (which is separate from the memory array) on DQ7–DQ0. Standard read cycle timings apply in this mode. Refer to the Autoselect Functions and Autoselect Command Sequence sections for more information.

### Standby Mode

When the system is not reading or writing to the device, it can place the device in the standby mode. In this mode, current consumption is greatly reduced, and the outputs are placed in the high impedance state, independent of the OE# input.

The device enters the CMOS standby mode when the CE# and RESET# inputs are both held at  $V_{CC} \pm 0.2$  V. The device requires standard access time ( $t_{CE}$ ) for read access when the device is in either of these standby modes, before it is ready to read data.

If the device is deselected during erasure or programming, the device draws active current until the operation is completed.

$I_{CC3}$  in the DC Characteristics table represents the standby current specification.

### Automatic Sleep Mode

The automatic sleep mode minimizes Flash device energy consumption. The device automatically enables this mode when addresses remain stable for  $t_{ACC} + 60$  ns. The automatic sleep mode is independent of the CE#, WE#, and OE# control signals. Standard address access timings provide new data when addresses are changed. While in sleep mode, output data is latched and always available to the system.  $I_{CC4}$  in the DC Characteristics table represents the automatic sleep mode current specification.

### RESET#: Hardware Reset Input

The RESET# input provides a hardware method of resetting the device to reading array data. When RESET# is driven low for at least a period of  $t_{RP}$  the device immediately terminates any operation in progress, tristates all outputs, and ignores all read/write commands for the duration of the RESET# pulse. The device also resets the internal state machine to reading array data. The operation that was interrupted should be reinitiated once the device is ready to accept another command sequence, to ensure data integrity.

Current is reduced for the duration of the RESET# pulse. When RESET# is held at  $V_{SS} \pm 0.2$  V, the device draws CMOS standby current ( $I_{CC4}$ ). If RESET# is held at  $V_{IL}$  but not within  $V_{SS} \pm 0.2$  V, the standby current will be greater.

RESET# may be tied to the system reset circuitry. A system reset would thus also reset the Flash memory, enabling the system to read the boot-up firmware from the Flash memory.

If RESET# is asserted during a program or erase operation, the device requires a time of  $t_{READY}$  (during Embedded Algorithms) before the device is ready to read data again. If RESET# is asserted when a program or erase operation is not executing, the reset operation is completed within a time of  $t_{READY}$  (not during Embedded Algorithms). The system can read data  $t_{RH}$  after RESET# returns to  $V_{IH}$ .

Refer to the AC Characteristics tables for RESET# parameters and to Figure 12 for the timing diagram.

### Output Disable Mode

When the OE# input is at  $V_{IH}$ , output from the device is disabled. The outputs are placed in the high impedance state.

## Hardware Data Protection

The command sequence requirement of unlock cycles for programming or erasing provides data protection against inadvertent writes (refer to Table 4 for command definitions).

The device offers three types of data protection at the sector level:

- The sector lock/unlock command sequence disables or re-enables both program and erase operations in any sector.
- When WP# is at  $V_{IL}$ , the two outermost sectors are locked.
- When  $V_{PP}$  is at  $V_{IL}$ , all sectors are locked.

The following hardware data protection measures prevent accidental erasure or programming, which might otherwise be caused by spurious system level signals during  $V_{CC}$  power-up and power-down transitions, or from system noise.

## Low $V_{CC}$ Write Inhibit

When  $V_{CC}$  is less than  $V_{LKO}$ , the device does not accept any write cycles. This protects data during  $V_{CC}$  power-up and power-down. The command register and all internal program/erase circuits are disabled, and the device resets to reading array data. Subsequent writes are ignored until  $V_{CC}$  is greater than  $V_{LKO}$ . The system must provide the proper signals to the control inputs to prevent unintentional writes when  $V_{CC}$  is greater than  $V_{LKO}$ .

## Write Pulse “Glitch” Protection

Noise pulses of less than 5 ns (typical) on OE#, CE# or WE# do not initiate a write cycle.

## Logical Inhibit

Write cycles are inhibited by holding any one of OE# =  $V_{IL}$ , CE# =  $V_{IH}$  or WE# =  $V_{IH}$ . To initiate a write cycle, CE# and WE# must be a logical zero while OE# is a logical one.

Table 2. Sector Address Table

	Sector	Sector Size	(x16) Address Range
<b>Bank B</b>	SA0	32 Kwords	000000h—007FFFh
	SA1	32 Kwords	008000h—00FFFFh
	SA2	32 Kwords	010000h—017FFFh
	SA3	32 Kwords	018000h—01FFFFh
	SA4	32 Kwords	020000h—027FFFh
	SA5	32 Kwords	028000h—02FFFFh
	SA6	32 Kwords	030000h—037FFFh
	SA7	32 Kwords	038000h—03FFFFh
	SA8	32 Kwords	040000h—047FFFh
	SA9	32 Kwords	048000h—04FFFFh
	SA10	32 Kwords	050000h—057FFFh
	SA11	32 Kwords	058000h—05FFFFh
	SA12	32 Kwords	060000h—067FFFh
	SA13	32 Kwords	068000h—06FFFFh
	SA14	32 Kwords	070000h—077FFFh
	SA15	32 Kwords	078000h—07FFFFh
	SA16	32 Kwords	080000h—087FFFh
	SA17	32 Kwords	088000h—08FFFFh
	SA18	32 Kwords	090000h—097FFFh
	SA19	32 Kwords	098000h—09FFFFh
	SA20	32 Kwords	0A0000h—0A7FFFh
	SA21	32 Kwords	0A8000h—0AFFFFh
	SA22	32 Kwords	0B0000h—0B7FFFh
	SA23	32 Kwords	0B8000h—0BFFFFh
	SA24	32 Kwords	0C0000h—0C7FFFh
	SA25	32 Kwords	0C8000h—0CFFFFh
	SA26	32 Kwords	0D0000h—0D7FFFh
	SA27	32 Kwords	0D8000h—0DFFFFh
	SA28	32 Kwords	0E0000h—0E7FFFh
	SA29	32 Kwords	0E8000h—0EFFFFh
	SA30	32 Kwords	0F0000h—0F7FFFh

Table 2. Sector Address Table (Continued)

	Sector	Sector Size	(x16) Address Range
Bank B	SA31	32 Kwords	0F8000h—0FFFFFFh
	SA32	32 Kwords	100000h—107FFFh
	SA33	32 Kwords	108000h—10FFFFFFh
	SA34	32 Kwords	110000h—117FFFh
	SA35	32 Kwords	118000h—11FFFFFFh
	SA36	32 Kwords	120000h—127FFFh
	SA37	32 Kwords	128000h—12FFFFFFh
	SA38	32 Kwords	130000h—137FFFh
	SA39	32 Kwords	138000h—13FFFFFFh
	SA40	32 Kwords	140000h—147FFFh
	SA41	32 Kwords	148000h—14FFFFFFh
	SA42	32 Kwords	150000h—157FFFh
	SA43	32 Kwords	158000h—15FFFFFFh
	SA44	32 Kwords	160000h—167FFFh
	SA45	32 Kwords	168000h—16FFFFFFh
	SA46	32 Kwords	170000h—177FFFh
	SA47	32 Kwords	178000h—17FFFFFFh
	SA48	32 Kwords	180000h—187FFFh
	SA49	32 Kwords	188000h—18FFFFFFh
	SA50	32 Kwords	190000h—197FFFh
	SA51	32 Kwords	198000h—19FFFFFFh
	SA52	32 Kwords	1A0000h—1A7FFFh
	SA53	32 Kwords	1A8000h—1AFFFFFFh
	SA54	32 Kwords	1B0000h—1B7FFFh
	SA55	32 Kwords	1B8000h—1BFFFFFFh
	SA56	32 Kwords	1C0000h—1C7FFFh
	SA57	32 Kwords	1C8000h—1CFFFFFFh
	SA58	32 Kwords	1D0000h—1D7FFFh
	SA59	32 Kwords	1D8000h—1DFFFFFFh
	SA60	32 Kwords	1E0000h—1E7FFFh
	SA61	32 Kwords	1E8000h—1EFFFFFFh
	SA62	32 Kwords	1F0000h—1F7FFFh
	SA63	32 Kwords	1F8000h—1FFFFFFh
	SA64	32 Kwords	200000h—207FFFh
	SA65	32 Kwords	208000h—20FFFFFFh
	SA66	32 Kwords	210000h—217FFFh
	SA67	32 Kwords	218000h—21FFFFFFh
	SA68	32 Kwords	220000h—227FFFh
	SA69	32 Kwords	228000h—22FFFFFFh
	SA70	32 Kwords	230000h—237FFFh
	SA71	32 Kwords	238000h—23FFFFFFh
	SA72	32 Kwords	240000h—247FFFh

Table 2. Sector Address Table (Continued)

	Sector	Sector Size	(x16) Address Range
Bank B	SA73	32 Kwords	248000h–24FFFFh
	SA74	32 Kwords	250000h–257FFFh
	SA75	32 Kwords	258000h–25FFFFh
	SA76	32 Kwords	260000h–267FFFh
	SA77	32 Kwords	268000h–26FFFFh
	SA78	32 Kwords	270000h–277FFFh
	SA79	32 Kwords	278000h–27FFFFh
	SA80	32 Kwords	280000h–287FFFh
	SA81	32 Kwords	288000h–28FFFFh
	SA82	32 Kwords	290000h–297FFFh
	SA83	32 Kwords	298000h–29FFFFh
	SA84	32 Kwords	2A0000h–2A7FFFh
	SA85	32 Kwords	2A8000h–2AFFFFh
	SA86	32 Kwords	2B0000h–2B7FFFh
	SA87	32 Kwords	2B8000h–2BFFFFh
	SA88	32 Kwords	2C0000h–2C7FFFh
	SA89	32 Kwords	2C8000h–2CFFFFh
	SA90	32 Kwords	2D0000h–2D7FFFh
	SA91	32 Kwords	2D8000h–2DFFFFh
	SA92	32 Kwords	2E0000h–2E7FFFh
SA93	32 Kwords	2E8000h–2EFFFFh	
SA94	32 Kwords	2F0000h–2F7FFFh	
SA95	32 Kwords	2F8000h–2FFFFFh	
Bank A	SA96	32K words	300000h–307FFFh
	SA97	32K words	308000h–30FFFFh
	SA98	32K words	310000h–317FFFh
	SA99	32K words	318000h–31FFFFh
	SA100	32K words	320000h–327FFFh
	SA101	32K words	328000h–32FFFFh
	SA102	32K words	330000h–337FFFh
	SA103	32K words	338000h–33FFFFh
	SA104	32K words	340000h–347FFFh
	SA105	32K words	348000h–34FFFFh
	SA106	32K words	350000h–357FFFh
	SA107	32K words	358000h–35FFFFh
	SA108	32K words	360000h–367FFFh
	SA109	32K words	368000h–36FFFFh
SA110	32K words	370000h–377FFFh	
SA111	32K words	378000h–37FFFFh	
SA112	32K words	380000h–387FFFh	
SA113	32K words	388000h–38FFFFh	

Table 2. Sector Address Table (Continued)

	Sector	Sector Size	(x16) Address Range
<b>Bank A</b>	SA114	32K words	390000h–397FFFh
	SA115	32K words	398000h–39FFFFh
	SA116	32K words	3A0000h–3A7FFFh
	SA117	32K words	3A8000h–3AFFFFh
	SA118	32K words	3B0000h–3B7FFFh
	SA119	32K words	3B8000h–3BFFFFh
	SA120	32K words	3C0000h–3C7FFFh
	SA121	32K words	3C8000h–3CFFFFh
	SA122	32K words	3D0000h–3D7FFFh
	SA123	32K words	3D8000h–3DFFFFh
	SA124	32K words	3E0000h–3E7FFFh
	SA125	32K words	3E8000h–3EFFFFh
	SA126	32K words	3F0000h–3F7FFFh
	SA127	4K words	3F8000h–3F8FFFh
	SA128	4K words	3F9000h–3F9FFFh
	SA129	4K words	3FA000h–3FAFFFh
	SA130	4K words	3FB000h–3FBFFFh
	SA131	4K words	3FC000h–3FCFFFh
SA132	4K words	3FD000h–3FDFFFh	
SA133	4K words	3FE000h–3FEFFFh	
SA134	4K words	3FF000h–3FFFFFh	



## COMMAND DEFINITIONS

Writing specific address and data commands or sequences into the command register initiates device operations. Table 4 defines the valid register command sequences. Writing **incorrect address and data values** or writing them in the **improper sequence** resets the device to reading array data.

All addresses are latched on the rising edge of AVD#. All data is latched on the rising edge of WE#. Refer to the AC Characteristics section for timing diagrams.

### Reading Array Data

The device is automatically set to reading array data after device power-up. No commands are required to retrieve data in asynchronous mode. Each bank is ready to read array data after completing an Embedded Program or Embedded Erase algorithm.

After the device accepts an Erase Suspend command, the corresponding bank enters the erase-suspend-read mode, after which the system can read data from any non-erase-suspended sector within the same bank. After completing a programming operation in the Erase Suspend mode, the system may once again read array data with the same exception. See the Erase Suspend/Erase Resume Commands section for more information.

The system *must* issue the reset command to return a bank to the read (or erase-suspend-read) mode if DQ5 goes high during an active program or erase operation, or if the bank is in the autoselect mode. See the next section, Reset Command, for more information.

See also Requirements for Asynchronous Read Operation (Non-Burst) and Requirements for Synchronous (Burst) Read Operation in the Device Bus Operations section for more information. The Asynchronous Read and Synchronous/Burst Read tables provide the read parameters, and Figures 9 and 11 show the timings.

### Set Wait State Command Sequence

The wait state command sequence instructs the device to set a particular number of clock cycles for the initial access in burst mode. The number of wait states that should be programmed into the device is directly related to the clock frequency. The first two cycles of the command sequence are for unlock purposes. On the third cycle, the system should write C0h to the address associated with the intended wait state setting (see Table 3). Address bits A12 and A13 determine the setting.

**Table 3. Third Cycle Address/Data**

Address	A13	A12	Total Initial Access Cycles	Data
000555h	0	0	4	C0h
001555h	0	1	5	
002555h	1	0	6	
003555h	1	1	7	

Upon power up, the device defaults to the maximum seven cycle wait state setting (see Figure 20). It is recommended that the wait state command sequence be written, even if the default wait state value is desired, to ensure the device is set as expected. A hardware reset will set the wait state to the default setting.

### Handshaking

The host system should set the wait states to 00h for a clock frequency of 40 MHz or to 01h for a clock frequency of 54 MHz.

### Enable PS (Power Saving) Mode Command Sequence

The Enable PS (Power Saving) Mode command sequence is required to set the device to the PS mode. On power up, the Power Saving mode is disabled. The command sequence consists of two unlock cycles followed by a command cycle in which the address and data should 555h/70h, respectively. The PS mode remains enabled until the device is hardware reset (either device is powered down or RESET# is asserted low).

### Sector Lock/Unlock Command Sequence

The sector lock/unlock command sequence allows the system to determine which sectors are protected from accidental writes. When the device is first powered up, all sectors are locked. To unlock a sector, the system must write the sector lock/unlock command sequence. Two cycles are first written: addresses are don't care and data is 60h. During the third cycle, the sector address (SLA) and unlock command (60h) is written, while specifying with address A6 whether that sector should be locked ( $A6 = V_{IL}$ ) or unlocked ( $A6 = V_{IH}$ ). After the third cycle, the system can continue to lock or unlock additional cycles, or exit the sequence by writing F0h (reset command).

Note that the last two outermost boot sectors can be locked by taking the WP# signal to  $V_{IL}$ . Also, if  $V_{PP}$  is at  $V_{IL}$  all sectors are locked; if the  $V_{PP}$  input is at  $V_{PP}$  all sectors are unlocked.

## Reset Command

Writing the reset command resets the banks to the read or erase-suspend-read mode. Address bits are don't cares for this command.

The reset command may be written between the sequence cycles in an erase command sequence before erasing begins. This resets the bank to which the system was writing to the read mode. Once erasure begins, however, the device ignores reset commands until the operation is complete.

The reset command may be written between the sequence cycles in a program command sequence before programming begins. This resets the bank to which the system was writing to the read mode. If the program command sequence is written to a bank that is in the Erase Suspend mode, writing the reset command returns that bank to the erase-suspend-read mode. Once programming begins, however, the device ignores reset commands until the operation is complete.

The reset command may be written between the sequence cycles in an autoselect command sequence. Once in the autoselect mode, the reset command must be written to return to the read mode. If a bank entered the autoselect mode while in the Erase Suspend mode, writing the reset command returns that bank to the erase-suspend-read mode.

If DQ5 goes high during a program or erase operation, writing the reset command returns the banks to the read mode (or erase-suspend-read mode if that bank was in Erase Suspend).

## Autoselect Command Sequence

The autoselect command sequence allows the host system to access the manufacturer and device codes, and determine whether or not a sector is protected. Table 4 shows the address and data requirements. The autoselect command sequence may be written to an address within a bank that is either in the read or erase-suspend-read mode. The autoselect command may not be written while the device is actively programming or erasing in the other bank.

The autoselect command sequence is initiated by first writing two unlock cycles. This is followed by a third write cycle that contains the bank address and the autoselect command. The bank then enters the autoselect mode. The system may read at any address within the same bank any number of times without initiating another autoselect command sequence. The following table describes the address requirements for the various autoselect functions, and the resulting data. BA represents the bank address, and SA represents

the sector address. The device ID is read in three cycles.

Description	Address	Read Data
Manufacturer ID	(BA) + 00h	0001h
Device ID, Word 1	(BA) + 01h	227Eh
Device ID, Word 2	(BA) + 0Eh	2202h
Device ID, Word 3	(BA) + 0Fh	2200h
Sector Block Lock/Unlock	(SA) + 02h	0001 (locked), 0000 (unlocked)
Handshaking Enabled	(BA) + 03h	40h

The system must write the reset command to return to the read mode (or erase-suspend-read mode if the bank was previously in Erase Suspend).

## Program Command Sequence

Programming is a four-bus-cycle operation. The program command sequence is initiated by writing two unlock write cycles, followed by the program set-up command. The program address and data are written next, which in turn initiate the Embedded Program algorithm. The system is *not* required to provide further controls or timings. The device automatically provides internally generated program pulses and verifies the programmed cell margin. Table 4 shows the address and data requirements for the program command sequence.

When the Embedded Program algorithm is complete, that bank then returns to the read mode and addresses are no longer latched. The system can determine the status of the program operation by monitoring DQ7 or DQ6/DQ2. Refer to the Write Operation Status section for information on these status bits.

Any commands written to the device during the Embedded Program Algorithm are ignored. Note that a **hardware reset** immediately terminates the program operation. The program command sequence should be reinitiated once that bank has returned to the read mode, to ensure data integrity.

Programming is allowed in any sequence and across sector boundaries. **A bit cannot be programmed from “0” back to a “1.”** Attempting to do so may cause that bank to set DQ5 = 1, or cause the DQ7 and DQ6 status bit to indicate the operation was successful. However, a succeeding read will show that the data is still “0.” Only erase operations can convert a “0” to a “1.”

## Unlock Bypass Command Sequence

The unlock bypass feature allows the system to primarily program to a bank faster than using the standard

program command sequence. The unlock bypass command sequence is initiated by first writing two unlock cycles. This is followed by a third write cycle containing the unlock bypass command, 20h. That bank then enters the unlock bypass mode. A two-cycle unlock bypass program command sequence is all that is required to program in this mode. The first cycle in this sequence contains the unlock bypass program command, A0h; the second cycle contains the program address and data. Additional data is programmed in the same manner. This mode dispenses with the initial two unlock cycles required in the standard program command sequence, resulting in faster total programming time. The host system may also initiate the chip erase and sector erase sequences in the unlock bypass mode. The erase command sequences are four cycles in length instead of six cycles. Table 4 shows the requirements for the unlock bypass command sequences.

During the unlock bypass mode, only the Unlock Bypass Program and Unlock Bypass Reset commands are valid. To exit the unlock bypass mode, the system must issue the two-cycle unlock bypass reset command sequence. The first cycle must contain the bank address and the data 90h. The second cycle need only contain the data 00h. The bank then returns to the read mode.

The device offers accelerated program operations through the  $V_{PP}$  input. When the system asserts  $V_{PP}$  on this input, the device automatically enters the Unlock Bypass mode. The system may then write the two-cycle Unlock Bypass program command sequence. The device uses the higher voltage on the  $V_{PP}$  input to accelerate the operation. Note that sectors must be unlocked using the Sector Lock/Unlock command sequence prior to raising  $V_{PP}$  to  $V_{ID}$ .

Figure 1 illustrates the algorithm for the program operation. Refer to the Erase/Program Operations table in the AC Characteristics section for parameters, and Figure 13 for timing diagrams.

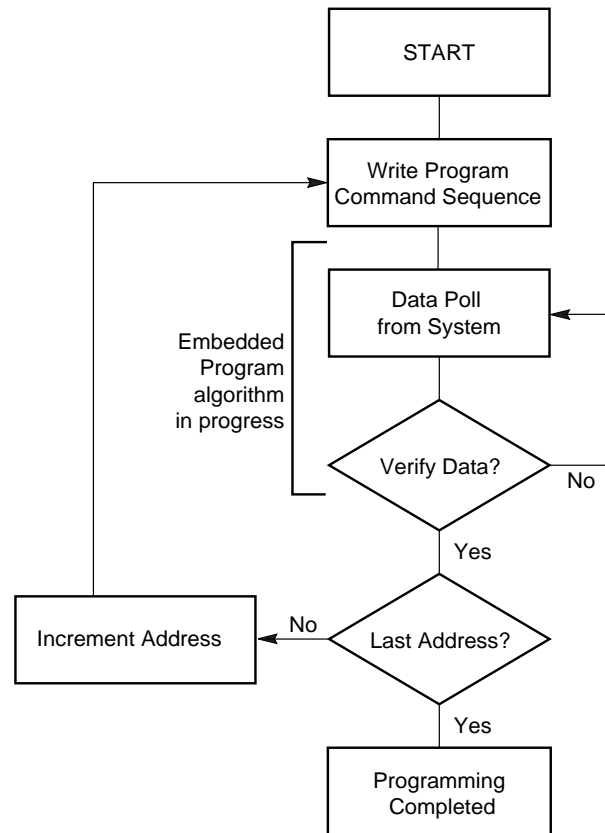

**Note:** See Table 4 for program command sequence.

**Figure 1. Program Operation**

## Chip Erase Command Sequence

Chip erase is a six bus cycle operation. The chip erase command sequence is initiated by writing two unlock cycles, followed by a set-up command. Two additional unlock write cycles are then followed by the chip erase command, which in turn invokes the Embedded Erase algorithm. The device does *not* require the system to preprogram prior to erase. The Embedded Erase algorithm automatically preprograms and verifies the entire memory for an all zero data pattern prior to electrical erase. The system is not required to provide any controls or timings during these operations. Table 4 shows the address and data requirements for the chip erase command sequence.

When the Embedded Erase algorithm is complete, that bank returns to the read mode and addresses are no longer latched. The system can determine the status of the erase operation by using DQ7 or DQ6/DQ2. Refer to the Write Operation Status section for information on these status bits.

Any commands written during the chip erase operation are ignored. However, note that a **hardware reset** immediately terminates the erase operation. If that occurs, the chip erase command sequence should be reinitiated once that bank has returned to reading array data, to ensure data integrity.

The host system may also initiate the chip erase command sequence while the device is in the unlock bypass mode. The command sequence is two cycles in length instead of six cycles. See Table 4 for details on the unlock bypass command sequences.

Figure 2 illustrates the algorithm for the erase operation. Refer to the Erase/Program Operations table in the AC Characteristics section for parameters, and Figure 14 section for timing diagrams.

### Sector Erase Command Sequence

Sector erase is a six bus cycle operation. The sector erase command sequence is initiated by writing two unlock cycles, followed by a set-up command. Two additional unlock cycles are written, and are then followed by the address of the sector to be erased, and the sector erase command. Table 4 shows the address and data requirements for the sector erase command sequence.

The device does *not* require the system to preprogram prior to erase. The Embedded Erase algorithm automatically programs and verifies the entire memory for an all zero data pattern prior to electrical erase. The system is not required to provide any controls or timings during these operations.

After the command sequence is written, a sector erase time-out of no less than 50  $\mu$ s occurs. During the time-out period, additional sector addresses and sector erase commands may be written. Loading the sector erase buffer may be done in any sequence, and the number of sectors may be from one sector to all sectors. The time between these additional cycles must be less than 50  $\mu$ s, otherwise erasure may begin. Any sector erase address and command following the exceeded time-out may or may not be accepted. It is recommended that processor interrupts be disabled during this time to ensure all commands are accepted. The interrupts can be re-enabled after the last Sector Erase command is written. **Any command other than Sector Erase or Erase Suspend during the time-out period resets that bank to the read mode.** The system must rewrite the command sequence and any additional addresses and commands.

The system can monitor DQ3 to determine if the sector erase timer has timed out (See the section on DQ3: Sector Erase Timer.). The time-out begins from the rising edge of the final WE# pulse in the command sequence.

When the Embedded Erase algorithm is complete, the bank returns to reading array data and addresses are no longer latched. Note that while the Embedded Erase operation is in progress, the system can read data from the non-erasing bank. The system can determine the status of the erase operation by reading DQ7 or DQ6/DQ2 in the erasing bank. Refer to the Write Operation Status section for information on these status bits.

Once the sector erase operation has begun, only the Erase Suspend command is valid. All other commands are ignored. However, note that a **hardware reset** immediately terminates the erase operation. If that occurs, the sector erase command sequence should be reinitiated once that bank has returned to reading array data, to ensure data integrity.

The host system may also initiate the sector erase command sequence while the device is in the unlock bypass mode. The command sequence is four cycles in length instead of six cycles.

Figure 2 illustrates the algorithm for the erase operation. Refer to the Erase/Program Operations table in the AC Characteristics section for parameters, and Figure 14 section for timing diagrams.

### Erase Suspend/Erase Resume Commands

The Erase Suspend command, B0h, allows the system to interrupt a sector erase operation and then read data from, or program data to, any sector not selected for erasure. The bank address is required when writing this command. This command is valid only during the sector erase operation, including the minimum 50  $\mu$ s time-out period during the sector erase command sequence. The Erase Suspend command is ignored if written during the chip erase operation or Embedded Program algorithm.

When the Erase Suspend command is written during the sector erase operation, the device requires a maximum of 20  $\mu$ s to suspend the erase operation. However, when the Erase Suspend command is written during the sector erase time-out, the device immediately terminates the time-out period and suspends the erase operation.

After the erase operation has been suspended, the bank enters the erase-suspend-read mode. The system can read data from or program data to any sector not selected for erasure. (The device “erase suspends” all sectors selected for erasure.) Reading at any address within erase-suspended sectors produces status information on DQ7–DQ0. The system can use DQ7, or DQ6 and DQ2 together, to determine if a sector is actively erasing or is erase-suspended. Refer to the Write Operation Status section for information on these status bits.

After an erase-suspended program operation is complete, the bank returns to the erase-suspend-read mode. The system can determine the status of the program operation using the DQ7 or DQ6 status bits, just as in the standard program operation. Refer to the Write Operation Status section for more information.

In the erase-suspend-read mode, the system can also issue the autoselect command sequence. Refer to the Autoselect Functions and Autoselect Command Sequence sections for details.

To resume the sector erase operation, the system must write the Erase Resume command. The bank address of the erase-suspended bank is required when writing this command. Further writes of the Resume command are ignored. Another Erase Suspend command can be written after the chip has resumed erasing.

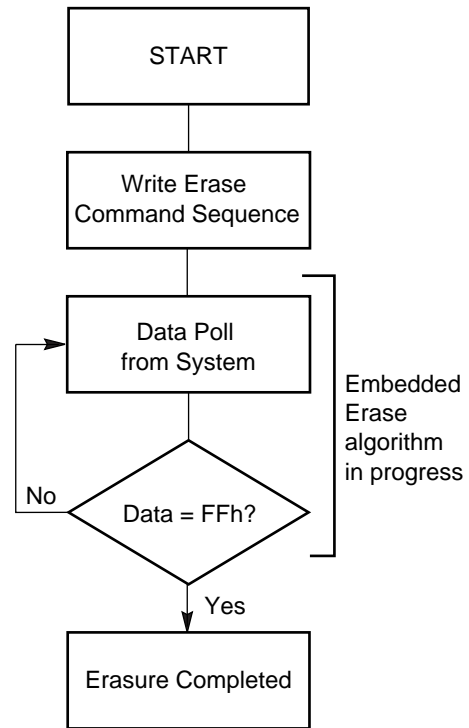

**Notes:**

1. See Table 4 for erase command sequence.
2. See the section on DQ3 for information on the sector erase timer.

**Figure 2. Erase Operation**

Command Definitions

Table 4. Command Definitions

Command Sequence (Note 1)	Cycles	Bus Cycles (Notes 2–5)												
		First		Second		Third		Fourth		Fifth		Sixth		
		Addr	Data	Addr	Data	Addr	Data	Addr	Data	Addr	Data	Addr	Data	
Asynchronous Read (Note 6)	1	RA	RD											
Reset (Note 7)	1	XXX	F0											
Autoselect (Note 8)	Manufacturer ID	4	555	AA	2AA	55	(BA)555	90	(BA)X00	0001				
	Device ID	6	555	AA	2AA	55	(BA)555	90	(BA)X01	227E	(BA)X0E	2202	(BA)X0F	2200
	Sector Lock Verify (Note 9)	4	555	AA	2AA	55	(SA)555	90	(SA)X02	0000	0001			
	Handshaking (Note 10)	4	555	AA	2AA	55	(BA)555	90	(BA)X03	0040				
Program	4	555	AA	2AA	55	555	A0	PA	Data					
Unlock Bypass	3	555	AA	2AA	55	555	20							
Unlock Bypass Program (Note 11)	2	XXX	A0	PA	PD									
Unlock Bypass Sector Erase (Note 11)	2	XXX	80	SA	30									
Unlock Bypass Chip Erase (Note 11)	2	XXX	80	XXX	10									
Unlock Bypass Reset (Note 12)	2	BA	90	XXX	00									
Chip Erase	6	555	AA	2AA	55	555	80	555	AA	2AA	55	555	10	
Sector Erase	6	555	AA	2AA	55	555	80	555	AA	2AA	55	SA	30	
Erase Suspend (Note 13)	1	BA	B0											
Erase Resume (Note 14)	1	BA	30											
Sector Lock/Unlock	3	XXX	60	XXX	60	SLA	60							
Set Wait Count (Note 15)	3	555	AA	2AA	55	(WS)555	C0							
Enable PS Mode	3	555	AA	2AA	55	555	70							

Legend:

X = Don't care  
 RA = Address of the memory location to be read.  
 RD = Data read from location RA during read operation.  
 PA = Address of the memory location to be programmed. Addresses latch on the falling edge of the WE# or CE# pulse, whichever happens later.  
 PD = Data to be programmed at location PA. Data latches on the rising edge of WE# or CE# pulse, whichever happens first.

SA = Address of the sector to be verified (in autoselect mode) or erased. Address bits A21–A12 uniquely select any sector.  
 BA = Address of the bank (A21, A20) that is being switched to autoselect mode, is in bypass mode, or is being erased.  
 SLA = Address of the sector to be locked. Set sector address (SA) and either A6 = 1 for unlocked or A6 = 0 for locked.  
 WS = Number of wait states defined by A12, A13.

Notes:

- See Table 1 for description of bus operations.
- All values are in hexadecimal.
- Except for the read cycle and the fourth cycle of the autoselect command sequence, all bus cycles are write cycles.
- Data bits DQ15–DQ8 are don't care in command sequences, except for RD and PD.
- Unless otherwise noted, address bits A21–A12 are don't cares.
- No unlock or command cycles required when bank is reading array data.
- The Reset command is required to return to reading array data (or to the erase-suspend-read mode if previously in Erase Suspend) when a bank is in the autoselect mode, or if DQ5 goes high (while the bank is providing status information).
- The fourth cycle of the autoselect command sequence is a read cycle. The system must provide the bank address. See the Autoselect Command Sequence section for more information.
- The data is 0000h for an unlocked sector and 0001h for a locked sector
- The data is 0040h for handshaking enabled.
- The Unlock Bypass command sequence is required prior to this command sequence.
- The Unlock Bypass Reset command is required to return to reading array data when the bank is in the unlock bypass mode.
- The system may read and program in non-erasing sectors, or enter the autoselect mode, when in the Erase Suspend mode. The Erase Suspend command is valid only during a sector erase operation, and requires the bank address.
- The Erase Resume command is valid only during the Erase Suspend mode, and requires the bank address.
- The addresses in the third cycle must contain, on A12 and A13, the additional wait counts to be set. See "Set Wait State Command Sequence".

## WRITE OPERATION STATUS

The device provides several bits to determine the status of a program or erase operation: DQ2, DQ3, DQ5, DQ6, and DQ7. Table 6 and the following subsections describe the function of these bits. DQ7 and DQ6 each offers a method for determining whether a program or erase operation is complete or in progress.

### DQ7: Data# Polling

The Data# Polling bit, DQ7, indicates to the host system whether an Embedded Program or Erase algorithm is in progress or completed, or whether a bank is in Erase Suspend. Data# Polling is valid after the rising edge of the final WE# pulse in the command sequence.

During the Embedded Program algorithm, the device outputs on DQ7 the complement of the datum programmed to DQ7. This DQ7 status also applies to programming during Erase Suspend. When the Embedded Program algorithm is complete, the device outputs the datum programmed to DQ7. The system must provide the program address to read valid status information on DQ7. If a program address falls within a protected sector, Data# Polling on DQ7 is active for approximately 1  $\mu$ s, then that bank returns to the read mode.

During the Embedded Erase algorithm, Data# Polling produces a “0” on DQ7. When the Embedded Erase algorithm is complete, or if the bank enters the Erase Suspend mode, Data# Polling produces a “1” on DQ7. The system must provide an address within any of the sectors selected for erasure to read valid status information on DQ7.

After an erase command sequence is written, if all sectors selected for erasing are protected, Data# Polling on DQ7 is active for approximately 100  $\mu$ s, then the bank returns to the read mode. If not all selected sectors are protected, the Embedded Erase algorithm erases the unprotected sectors, and ignores the selected sectors that are protected. However, if the system reads DQ7 at an address within a protected sector, the status may not be valid.

Just prior to the completion of an Embedded Program or Erase operation, DQ7 may change asynchronously with DQ0–DQ6 while Output Enable (OE#) is asserted low. That is, the device may change from providing status information to valid data on DQ7. Depending on when the system samples the DQ7 output, it may read the status or valid data. Even if the device has completed the program or erase operation and DQ7 has valid data, the data outputs on DQ0–DQ6 may be still

invalid. Valid data on DQ0–DQ7 will appear on successive read cycles.

Table 6 shows the outputs for Data# Polling on DQ7. Figure 3 shows the Data# Polling algorithm. Figure 16 in the AC Characteristics section shows the Data# Polling timing diagram.

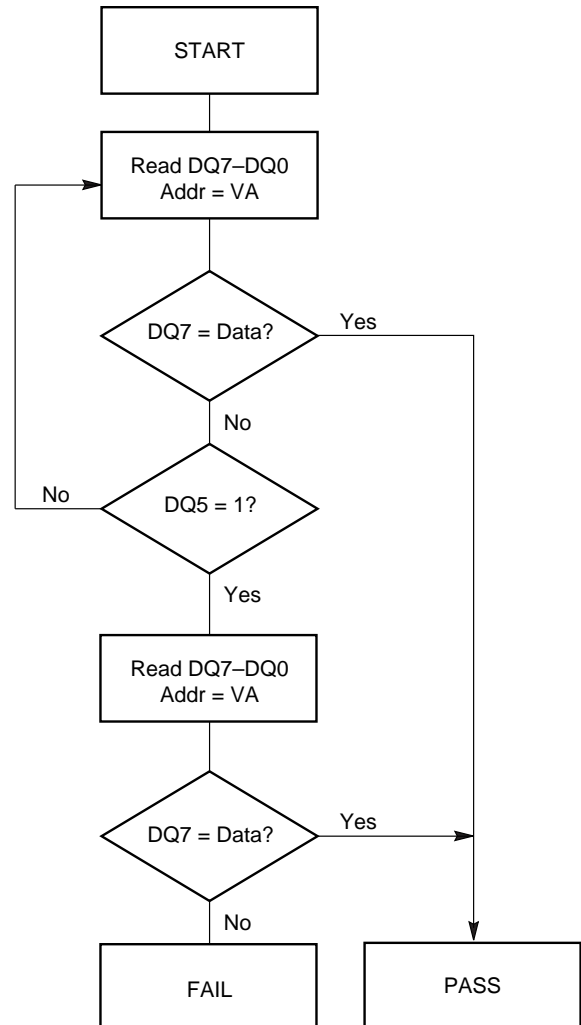

**Notes:**

1. VA = Valid address for programming. During a sector erase operation, a valid address is any sector address within the sector being erased. During chip erase, a valid address is any non-protected sector address.
2. DQ7 should be rechecked even if DQ5 = “1” because DQ7 may change simultaneously with DQ5.

**Figure 3. Data# Polling Algorithm**

**RDY: Ready**

The RDY is a dedicated output that indicates (when at logic low) the system should wait 1 clock cycle before expecting the next word of data.

RDY functions only while reading data in burst mode. The following conditions cause the RDY output to be low: during the initial access (in burst mode); after the boundary that occurs every 64 words beginning with the 63rd address, 3Eh; and when the clock frequency is less than 6 MHz (in which case RDY is low every third clock).

**DQ6: Toggle Bit I**

Toggle Bit I on DQ6 indicates whether an Embedded Program or Erase algorithm is in progress or complete, or whether the device has entered the Erase Suspend mode. Toggle Bit I may be read at any address in the same bank, and is valid after the rising edge of the final WE# pulse in the command sequence (prior to the program or erase operation), and during the sector erase time-out.

During an Embedded Program or Erase algorithm operation, successive read cycles to any address cause DQ6 to toggle. Note that OE# must be low during toggle bit status reads. When the operation is complete, DQ6 stops toggling.

After an erase command sequence is written, if all sectors selected for erasing are protected, DQ6 toggles for approximately 100 μs, then returns to reading array data. If not all selected sectors are protected, the Embedded Erase algorithm erases the unprotected sectors, and ignores the selected sectors that are protected.

The system can use DQ6 and DQ2 together to determine whether a sector is actively erasing or is erase-suspended. When the device is actively erasing (that is, the Embedded Erase algorithm is in progress), DQ6 toggles. When the device enters the Erase Suspend mode, DQ6 stops toggling. However, the system must also use DQ2 to determine which sectors are erasing or erase-suspended. Alternatively, the system can use DQ7 (see the subsection on DQ7: Data# Polling).

If a program address falls within a protected sector, DQ6 toggles for approximately 1 μs after the program command sequence is written, then returns to reading array data.

DQ6 also toggles during the erase-suspend-program mode, and stops toggling once the Embedded Program algorithm is complete.

See the following for additional information: Figure 4 (toggle bit flowchart), DQ6: Toggle Bit I (description), Figure 17 (toggle bit timing diagram), and Table 5 (compares DQ2 and DQ6).

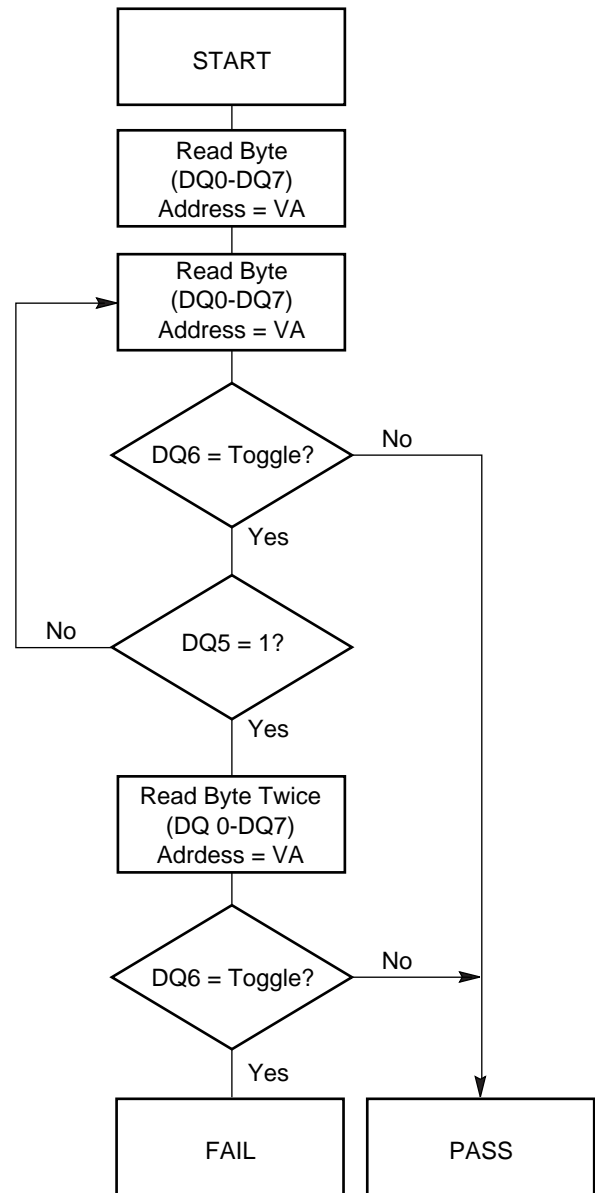

**Note:** The system should recheck the toggle bit even if DQ5 = "1" because the toggle bit may stop toggling as DQ5 changes to "1." See the subsections on DQ6 and DQ2 for more information.

**Figure 4. Toggle Bit Algorithm**



## DQ2: Toggle Bit II

The “Toggle Bit II” on DQ2, when used with DQ6, indicates whether a particular sector is actively erasing (that is, the Embedded Erase algorithm is in progress), or whether that sector is erase-suspended. Toggle Bit II is valid after the rising edge of the final WE# pulse in the command sequence.

DQ2 toggles when the system reads at addresses within those sectors that have been selected for erasure. Note that OE# must be low during toggle bit status reads. But DQ2 cannot distinguish whether the

sector is actively erasing or is erase-suspended. DQ6, by comparison, indicates whether the device is actively erasing, or is in Erase Suspend, but cannot distinguish which sectors are selected for erasure. Thus, both status bits are required for sector and mode information. Refer to Table 6 to compare outputs for DQ2 and DQ6.

See the following for additional information: Figure 4 (toggle bit flowchart), DQ6: Toggle Bit I (description), Figure 17 (toggle bit timing diagram), and Table 5 (compares DQ2 and DQ6).

**Table 5. DQ6 and DQ2 Indications**

If device is	and the system reads	then DQ6	and DQ2
programming,	at any address,	toggles,	does not toggle.
actively erasing,	at an address within a sector selected for erasure,	toggles,	also toggles.
	at an address within sectors <i>not</i> selected for erasure,	toggles,	does not toggle.
erase suspended,	at an address within a sector selected for erasure,	does not toggle,	toggles.
	at an address within sectors <i>not</i> selected for erasure,	returns array data,	returns array data. The system can read from any sector not selected for erasure.
programming in erase suspend	at any address,	toggles,	is not applicable.

## Reading Toggle Bits DQ6/DQ2

Refer to Figure 4 for the following discussion. Whenever the system initially begins reading toggle bit status, it must read DQ7–DQ0 at least twice in a row to determine whether a toggle bit is toggling. Typically, the system would note and store the value of the toggle bit after the first read. After the second read, the system would compare the new value of the toggle bit with the first. If the toggle bit is not toggling, the device has completed the program or erase operation. The system can read array data on DQ7–DQ0 on the following read cycle.

However, if after the initial two read cycles, the system determines that the toggle bit is still toggling, the system also should note whether the value of DQ5 is high (see the section on DQ5). If it is, the system should then determine again whether the toggle bit is toggling, since the toggle bit may have stopped toggling just as DQ5 went high. If the toggle bit is no longer toggling, the device has successfully completed the program or erase operation. If it is still toggling, the device did not completed the operation successfully,

and the system must write the reset command to return to reading array data.

The remaining scenario is that the system initially determines that the toggle bit is toggling and DQ5 has not gone high. The system may continue to monitor the toggle bit and DQ5 through successive read cycles, determining the status as described in the previous paragraph. Alternatively, it may choose to perform other system tasks. In this case, the system must start at the beginning of the algorithm when it returns to determine the status of the operation (top of Figure 4).

## DQ5: Exceeded Timing Limits

DQ5 indicates whether the program or erase time has exceeded a specified internal pulse count limit. Under these conditions DQ5 produces a “1,” indicating that the program or erase cycle was not successfully completed.

The device may output a “1” on DQ5 if the system tries to program a “1” to a location that was previously programmed to “0.” **Only an erase operation can change a “0” back to a “1.”** Under this condition, the device

halts the operation, and when the timing limit has been exceeded, DQ5 produces a “1.”

Under both these conditions, the system must write the reset command to return to the read mode (or to the erase-suspend-read mode if a bank was previously in the erase-suspend-program mode).

**DQ3: Sector Erase Timer**

After writing a sector erase command sequence, the system may read DQ3 to determine whether or not erasure has begun. (The sector erase timer does not apply to the chip erase command.) If additional sectors are selected for erasure, the entire time-out also applies after each additional sector erase command. When the time-out period is complete, DQ3 switches from a “0” to a “1.” If the time between additional sector erase commands from the system can be assumed to be less than 50 µs, the system need not monitor DQ3.

See also the Sector Erase Command Sequence section.

After the sector erase command is written, the system should read the status of DQ7 (Data# Polling) or DQ6 (Toggle Bit 1) to ensure that the device has accepted the command sequence, and then read DQ3. If DQ3 is “1,” the Embedded Erase algorithm has begun; all further commands (except Erase Suspend) are ignored until the erase operation is complete. If DQ3 is “0,” the device will accept additional sector erase commands. To ensure the command has been accepted, the system software should check the status of DQ3 prior to and following each subsequent sector erase command. If DQ3 is high on the second status check, the last command might not have been accepted.

Table 6 shows the status of DQ3 relative to the other status bits.

**Table 6. Write Operation Status**

Status		DQ7 (Note 2)	DQ6	DQ5 (Note 1)	DQ3	DQ2 (Note 2)	
Standard Mode	Embedded Program Algorithm	DQ7#	Toggle	0	N/A	No toggle	
	Embedded Erase Algorithm	0	Toggle	0	1	Toggle	
Erase Suspend Mode	Erase-Suspend-Read (Note 4)	Erase Suspended Sector	1	No toggle	0	N/A	Toggle
		Non-Erase Suspended Sector	Data	Data	Data	Data	Data
	Erase-Suspend-Program	DQ7#	Toggle	0	N/A	N/A	

**Notes:**

1. DQ5 switches to ‘1’ when an Embedded Program or Embedded Erase operation has exceeded the maximum timing limits. Refer to the section on DQ5 for more information.
2. DQ7 and DQ2 require a valid address when reading status information. Refer to the appropriate subsection for further details.
3. When reading write operation status bits, the system must always provide the bank address where the Embedded Algorithm is in progress. The device outputs array data if the system addresses a non-busy bank.
4. The system may read either asynchronously or synchronously (burst) while in erase suspend. RDY will function exactly as in non-erase-suspended mode.

## ABSOLUTE MAXIMUM RATINGS

Storage Temperature

Plastic Packages . . . . .  $-65^{\circ}\text{C}$  to  $+150^{\circ}\text{C}$

Ambient Temperature

with Power Applied. . . . .  $-65^{\circ}\text{C}$  to  $+125^{\circ}\text{C}$

Voltage with Respect to Ground,

All I/Os except  $V_{PP}$  (Note 1). . .  $-0.5\text{ V}$  to  $V_{CC} + 0.5\text{ V}$

$V_{CC}$  (Note 1). . . . .  $-0.5\text{ V}$  to  $+2.5\text{ V}$

$V_{PP}$  (Note 2). . . . .  $-0.5\text{ V}$  to  $+12.5\text{ V}$

Output Short Circuit Current (Note 3) . . . . . 100 mA

### Notes:

1. Minimum DC voltage on input or I/Os is  $-0.5\text{ V}$ . During voltage transitions, input at I/Os may undershoot  $V_{SS}$  to  $-2.0\text{ V}$  for periods of up to 20 ns during voltage transitions inputs might overshoot to  $V_{CC} + 0.5\text{ V}$  for periods up to 20 ns. See Figure 5. Maximum DC voltage on output and I/Os is  $V_{CC} + 0.5\text{ V}$ . During voltage transitions outputs may overshoot to  $V_{CC} + 2.0\text{ V}$  for periods up to 20 ns. See Figure 6.
2. Minimum DC input voltage on  $V_{PP}$  is  $-0.5\text{ V}$ . During voltage transitions,  $V_{PP}$  may overshoot  $V_{SS}$  to  $-2.0\text{ V}$  for periods of up to 20 ns. See Figure 5. Maximum DC input voltage on  $V_{PP}$  is  $+12.5\text{ V}$  which may overshoot to  $+13.5\text{ V}$  for periods up to 20 ns.
3. No more than one output may be shorted to ground at a time. Duration of the short circuit should not be greater than one second.
4. Stresses above those listed under "Absolute Maximum Ratings" may cause permanent damage to the device. This is a stress rating only; functional operation of the device at these or any other conditions above those indicated in the operational sections of this data sheet is not implied. Exposure of the device to absolute maximum rating conditions for extended periods may affect device reliability.

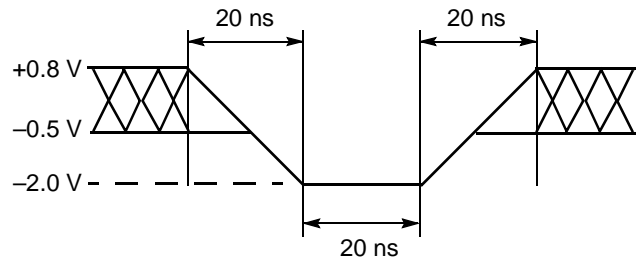

Figure 5. Maximum Negative Overshoot Waveform

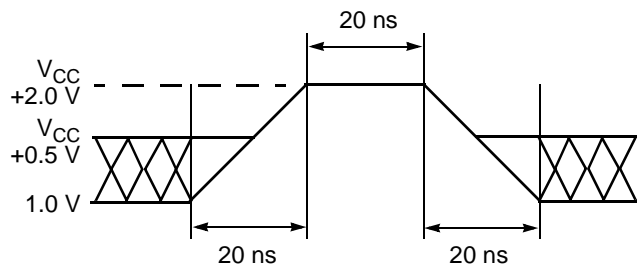

Figure 6. Maximum Positive Overshoot Waveform

## OPERATING RANGES

### Commercial (C) Devices

Ambient Temperature ( $T_A$ ) . . . . .  $0^{\circ}\text{C}$  to  $+70^{\circ}\text{C}$

### Industrial (I) Devices

Ambient Temperature ( $T_A$ ) . . . . .  $-40^{\circ}\text{C}$  to  $+85^{\circ}\text{C}$

### $V_{CC}$ Supply Voltages

$V_{CC}$  Supply Voltages . . . . .  $+1.7\text{ V}$  to  $+1.9\text{ V}$

Operating ranges define those limits between which the functionality of the device is guaranteed.

## DC CHARACTERISTICS

## CMOS Compatible

Parameter	Description	Test Conditions (Note 1)	Min	Typ	Max	Unit
$I_{LI}$	Input Load Current	$V_{IN} = V_{SS}$ to $V_{CC}$ , $V_{CC} = V_{CCmax}$			$\pm 1$	$\mu A$
$I_{LO}$	Output Leakage Current	$V_{OUT} = V_{SS}$ to $V_{CC}$ , $V_{CC} = V_{CCmax}$			$\pm 1$	$\mu A$
$I_{CCB1}$	$V_{CC}$ Active Burst Read Current	$CE\# = V_{IL}$ , $OE\# = V_{IL}$		25	30	mA
$I_{CCB2}$		$CE\# = V_{IL}$ , $OE\# = V_{IH}$ (Note 2)		0.5	1	mA
$I_{CC1}$	$V_{CC}$ Active Asynchronous Read Current (Note 3)	$CE\# = V_{IL}$ , $OE\# = V_{IH}$	5 MHz	12	16	mA
			1 MHz	3.5	5	mA
$I_{CC2}$	$V_{CC}$ Active Write Current (Note 4)	$CE\# = V_{IL}$ , $OE\# = V_{IH}$ , $V_{PP} = V_{IH}$		15	40	mA
$I_{CC3}$	$V_{CC}$ Standby Current (Note 5)	$CE\# = V_{IH}$ , $RESET\# = V_{IH}$		0.2	10	$\mu A$
$I_{CC4}$	$V_{CC}$ Reset Current	$RESET\# = V_{IL}$ , $CLK = V_{IL}$		0.2	10	$\mu A$
$I_{CC5}$	$V_{CC}$ Active Current (Read While Write)	$CE\# = V_{IL}$ , $OE\# = V_{IL}$		40	60	mA
$I_{PP}$	Accelerated Program Current (Note 6)	$CE\# = V_{IL}$ , $OE\# = V_{IH}$ , $V_{PP} = 12.0 \pm 0.5 V$	$V_{PP}$	7	15	mA
			$V_{CC}$	5	10	mA
$V_{IL}$	Input Low Voltage		-0.5		0.2	V
$V_{IH}$	Input High Voltage		$V_{CC} - 0.2$		$V_{CC} + 0.2$	V
$V_{OL}$	Output Low Voltage	$I_{OL} = 100 \mu A$ , $V_{CC} = V_{CCmin}$			0.1	V
$V_{OH}$	Output High Voltage	$I_{OH} = -100 \mu A$ , $V_{CC} = V_{CCmin}$	$V_{CC} - 0.1$			V
$V_{ID}$	Voltage for Accelerated Program		11.5		12.5	V
$V_{LKO}$	Low $V_{CC}$ Lock-out Voltage		1.0		1.4	V

**Note:**

1. Maximum  $I_{CC}$  specifications are tested with  $V_{CC} = V_{CCmax}$ .
2. When  $OE\# = V_{IH}$ , burst mode is deactivated. If  $OE\# = V_{IL}$  is reasserted, the last data prior to  $OE\# = V_{IH}$  will remain available from the device. A new burst read sequence is initiated when new address is asserted,  $AVD\# = V_{IL}$  and  $OE\# = V_{IH}$ .
3. The  $I_{CC}$  current listed is typically less than 2 mA/MHz, with  $OE\#$  at  $V_{IH}$ .
4.  $I_{CC}$  active while Embedded Erase or Embedded Program is in progress.
5. Device enters automatic sleep mode when addresses are stable for  $t_{ACC} + 60 ns$ . Typical sleep mode current is equal to  $I_{CC3}$ .
6. Total current during accelerated programming is the sum of  $V_{PP}$  and  $V_{CC}$  currents.

**TEST CONDITIONS**

**Table 7. Test Specifications**

Test Condition	9A, 9B	Unit
Output Load Capacitance, $C_L$ (including jig capacitance)	30	pF
Input Rise and Fall Times	5	ns
Input Pulse Levels	0.0– $V_{CC}$	V
Input timing measurement reference levels	$V_{CC}/2$	V
Output timing measurement reference levels	$V_{CC}/2$	V

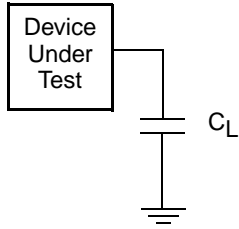
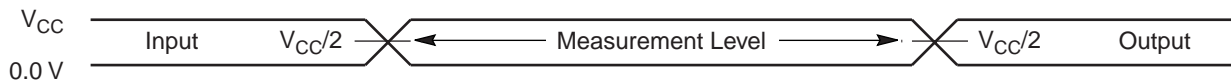

**Figure 7. Test Setup**

**KEY TO SWITCHING WAVEFORMS**

WAVEFORM	INPUTS	OUTPUTS
	Steady	
	Changing from H to L	
	Changing from L to H	
	Don't Care, Any Change Permitted	Changing, State Unknown
	Does Not Apply	Center Line is High Impedance State (High Z)

**SWITCHING WAVEFORMS**



**Figure 8. Input Waveforms and Measurement Levels**

**AC CHARACTERISTICS**  
**Synchronous/Burst Read**

Parameter		Description		9A	9B	Unit
JEDEC	Standard			(40 MHz)	(54 MHz)	
	$t_{IACC}$	Initial Access Time	Max	120	106	ns
	$t_{BACC}$	Burst Access Time Valid Clock to Output Delay	Max	20	13.5	ns
	$t_{AVDS}$	AVD# Setup Time to CLK	Min	5		ns
	$t_{AVDH}$	AVD# Hold Time from CLK	Min	7		ns
	$t_{AVDO}$	AVD# High to OE# Low	Min	0		ns
	$t_{ACS}$	Address Setup Time to CLK	Min	5		ns
	$t_{ACH}$	Address Hold Time from CLK	Min	7		ns
	$t_{BDH}$	Data Hold Time from Next Clock Cycle	Max	4		ns
	$t_{OE}$	Output Enable to Output Valid	Max	20		ns
	$t_{CEZ}$	Chip Enable to High Z	Max	10		ns
	$t_{OEZ}$	Output Enable to High Z	Max	10		ns
	$t_{CES}$	CE# Setup Time to CLK	Min	5		ns
	$t_{CEH}$	CE# Hold Time from CLK	Min	7		ns
	$t_{RDYS}$	RDY Setup Time to CLK	Min	5		ns
	$t_{RACC}$	Ready access time from CLK	Max	20	13.5	ns

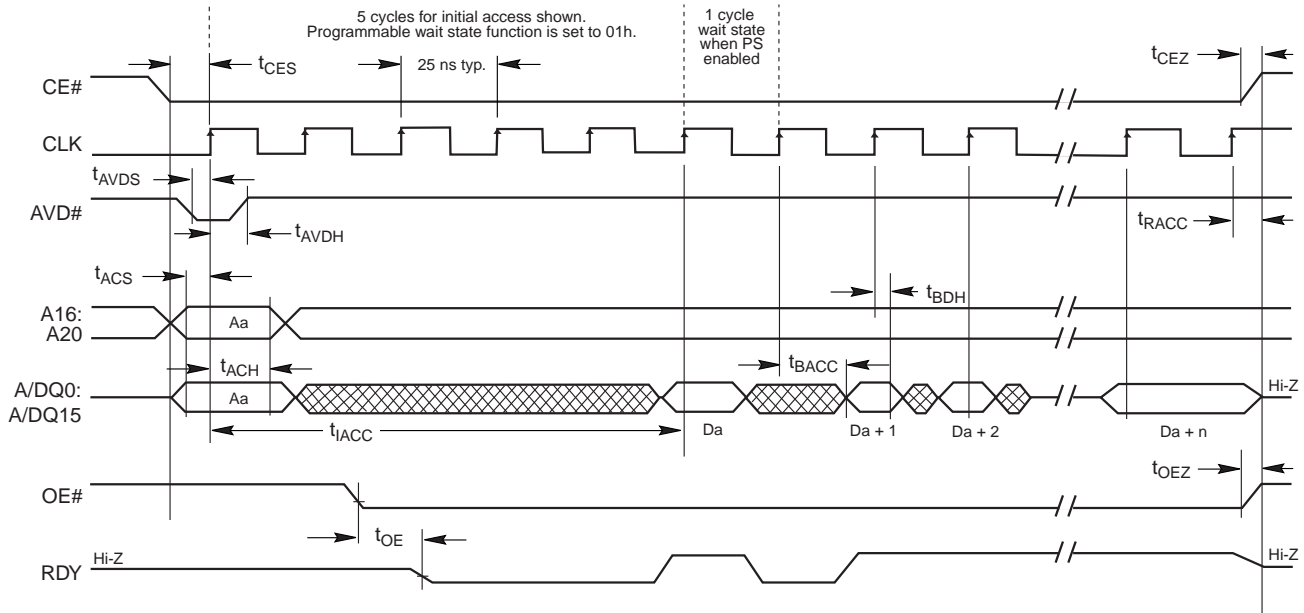

**Notes:**

1. Figure shows total number of wait states set to six cycles. The total number of wait states can be programmed from four cycles to seven cycles (non-handshaking devices only).
2. Figure shows that PS (power saving mode) has been enabled; one additional wait state occurs during initial data  $D_a$ . Latency is not present if PS is not enabled.
3. If any burst address occurs at a 64-word boundary, one additional clock cycle is inserted, and is indicated by RDY.

**Figure 9. Burst Mode Read (54 MHz)**

## AC CHARACTERISTICS

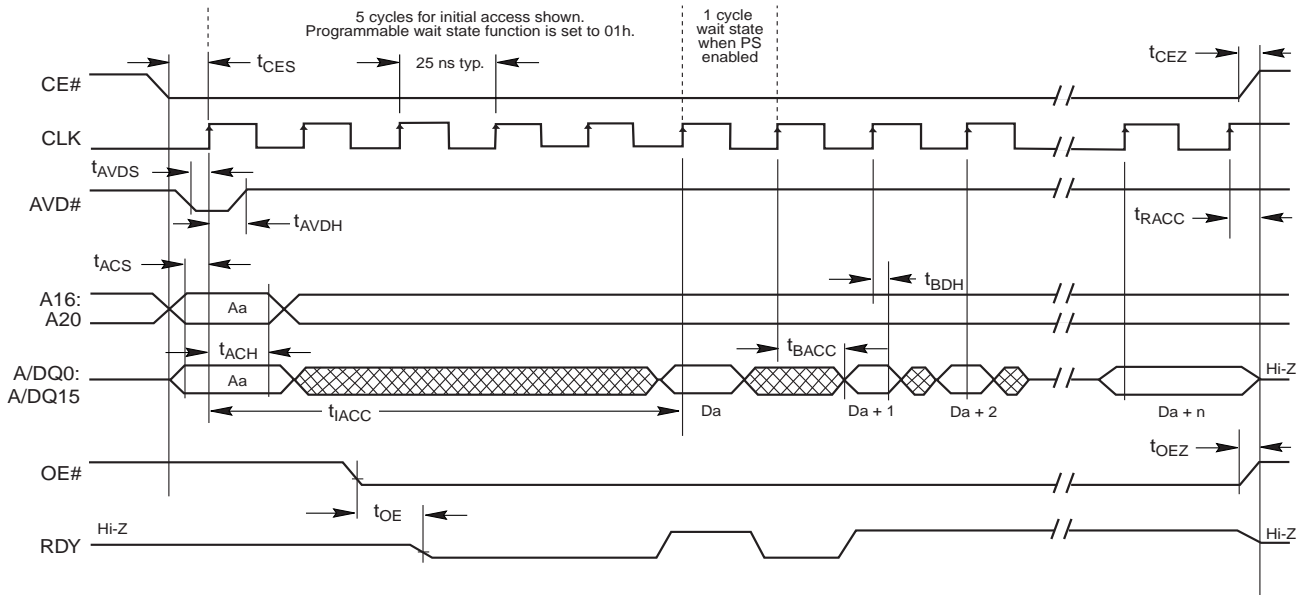

**Notes:**

1. Figure shows total number of wait states set to five cycles. The total number of wait states can be programmed from four cycles to seven cycles (non-handshaking devices only).
2. Figure shows that PS (power saving mode) has been enabled; one additional wait state occurs during initial data  $D_a$ . Latency is not present if PS is not enabled.
3. If any burst address occurs at a 64-word boundary, one additional clock cycle is inserted, and is indicated by RDY.

**Figure 10. Burst Mode Read (40 MHz)**

AC CHARACTERISTICS

Asynchronous Read

Parameter		Description		9A, 9B	Unit	
JEDEC	Standard					
	$t_{CE}$	Access Time from CE# Low	Max	90	ns	
	$t_{ACC}$	Asynchronous Access Time	Max	90	ns	
	$t_{AVDP}$	AVD# Low Time	Min	12	ns	
	$t_{AAVDS}$	Address Setup Time to Falling Edge of AVD	Min	5	ns	
	$t_{AAVDH}$	Address Hold Time from Rising Edge of AVD	Min	7	ns	
	$t_{OE}$	Output Enable to Output Valid	Max	20	ns	
	$t_{OE\ H}$	Output Enable Hold Time	Read	Min	0	ns
			Toggle and Data# Polling	Min	10	ns
	$t_{OEZ}$	Output Enable to High Z (See Note)	Max	10	ns	

Note: Not 100% tested.

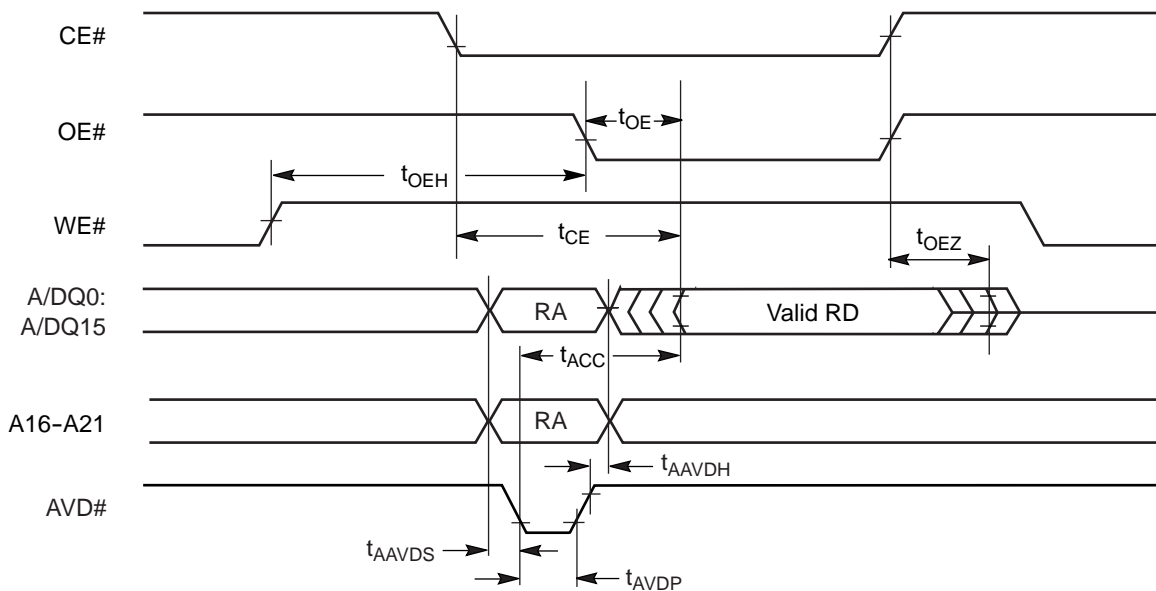

Note: RA = Read Address, RD = Read Data.

Figure 11. Asynchronous Mode Read



## AC CHARACTERISTICS

### Hardware Reset (RESET#)

Parameter		Description		All Speed Options	Unit
JEDEC	Std				
	$t_{Ready}$	RESET# Pin Low (During Embedded Algorithms) to Read Mode (See Note)	Max	20	$\mu$ s
	$t_{Ready}$	RESET# Pin Low (NOT During Embedded Algorithms) to Read Mode (See Note)	Max	500	ns
	$t_{RP}$	RESET# Pulse Width	Min	500	ns
	$t_{RH}$	Reset High Time Before Read (See Note)	Min	200	ns
	$t_{RPD}$	RESET# Low to Standby Mode	Min	20	$\mu$ s

**Note:** Not 100% tested.

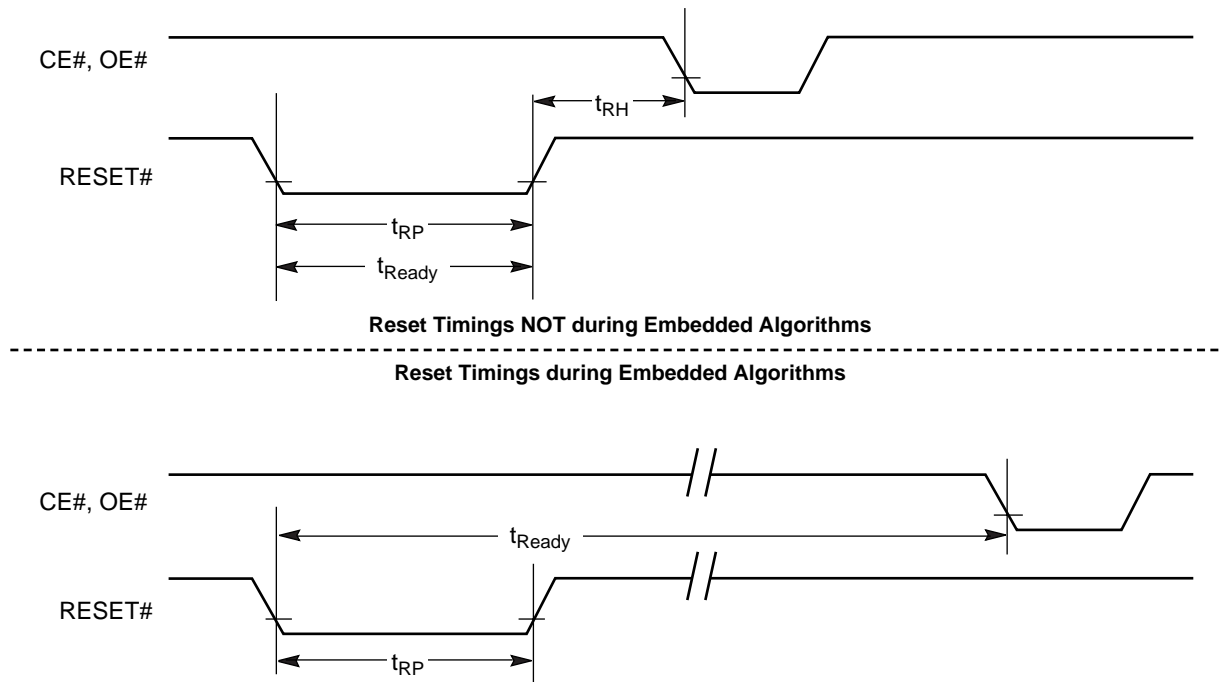

**Figure 12. Reset Timings**

## AC CHARACTERISTICS

## Erase/Program Operations

Parameter		Description		9A, 9B	Unit
JEDEC	Standard				
$t_{AVAV}$	$t_{WC}$	Write Cycle Time (Note 1)	Min	80	ns
$t_{AVWL}$	$t_{AS}$	Address Setup Time	Min	5	ns
$t_{WLAX}$	$t_{AH}$	Address Hold Time	Min	7	ns
	$t_{AVDP}$	AVD# Low Time	Min	12	ns
$t_{DVWH}$	$t_{DS}$	Data Setup Time	Min	45	ns
$t_{WHDX}$	$t_{DH}$	Data Hold Time	Min	0	ns
$t_{GHWL}$	$t_{GHWL}$	Read Recovery Time Before Write	Typ	0	ns
$t_{ELWL}$	$t_{CS}$	CE# Setup Time	Typ	0	ns
$t_{WHEH}$	$t_{CH}$	CE# Hold Time	Typ	0	ns
$t_{WLWH}$	$t_{WP}/t_{WRL}$	Write Pulse Width	Typ	50	ns
$t_{WHWL}$	$t_{WPH}$	Write Pulse Width High	Typ	30	ns
	$t_{SR/W}$	Latency Between Read and Write Operations	Min	0	ns
$t_{WHWH1}$	$t_{WHWH1}$	Programming Operation (Note 2)	Typ	11.5	$\mu$ s
$t_{WHWH1}$	$t_{WHWH1}$	Accelerated Programming Operation (Note 2)	Typ	4	$\mu$ s
$t_{WHWH2}$	$t_{WHWH2}$	Sector Erase Operation (Notes 2, 3)	Typ	1.5	sec
	$t_{VPP}$	$V_{PP}$ Rise and Fall Time	Min	500	ns
	$t_{VPS}$	$V_{PP}$ Setup Time (During Accelerated Programming)	Min	1	$\mu$ s
	$t_{VCS}$	$V_{CC}$ Setup Time	Min	50	$\mu$ s

**Notes:**

1. Not 100% tested.
2. See the "Erase and Programming Performance" section for more information.
3. Does not include the preprogramming time.

### AC CHARACTERISTICS

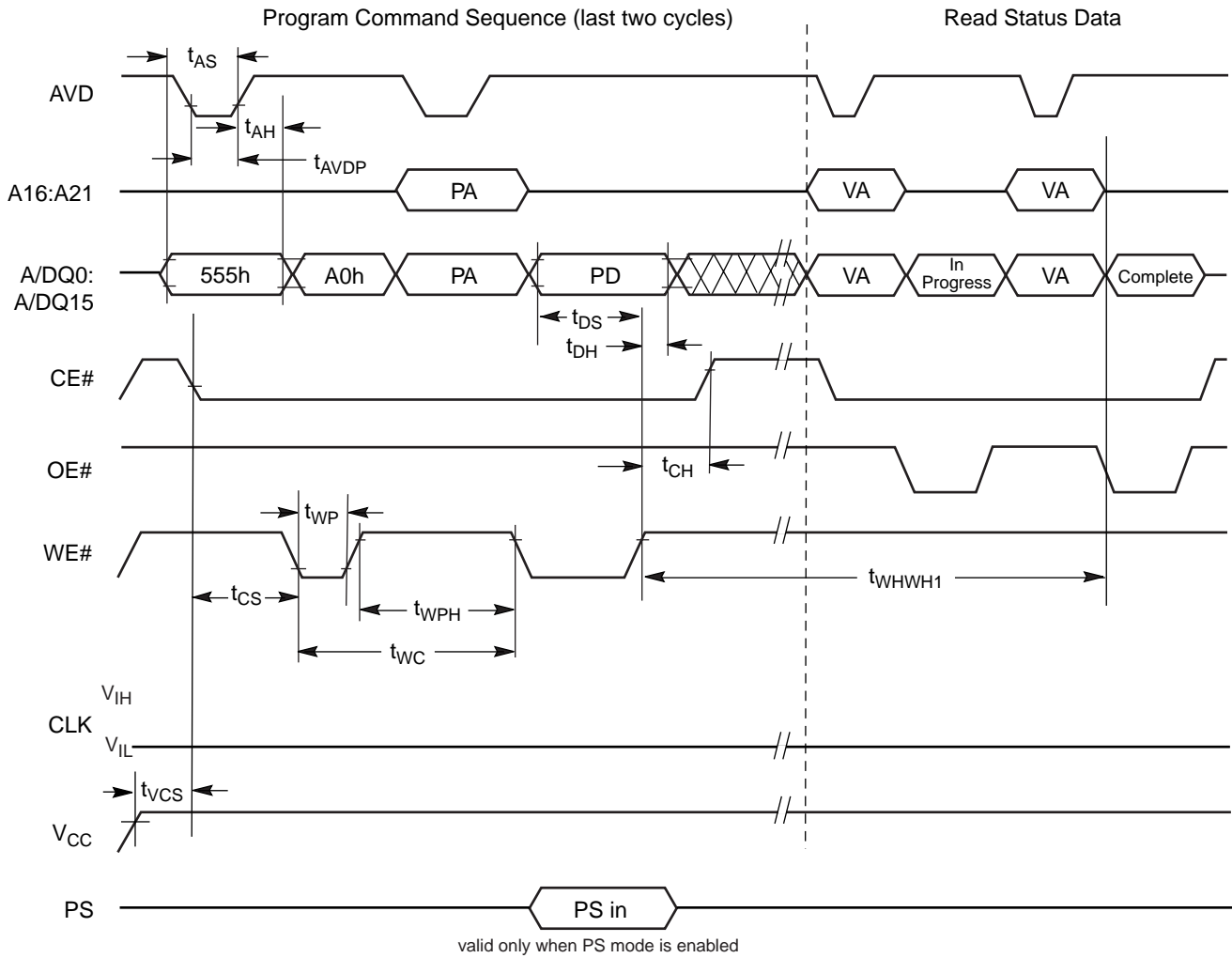

**Notes:**

1. PA = Program Address, PD = Program Data, VA = Valid Address for reading status bits.
2. "In progress" and "complete" refer to status of program operation.
3. A16–A21 are don't care during command sequence unlock cycles.

**Figure 13. Program Operation Timings**

AC CHARACTERISTICS

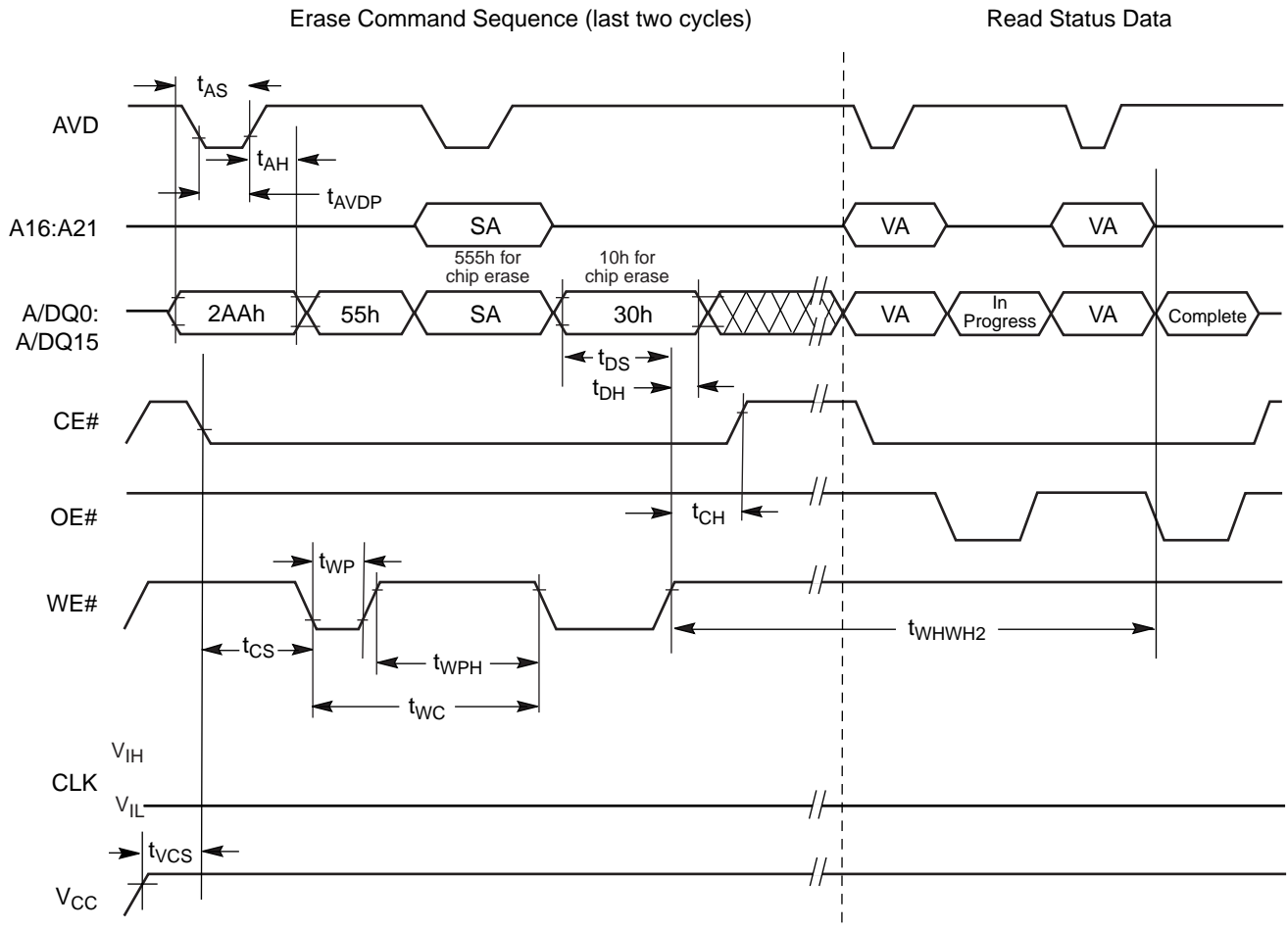

**Notes:**

1. SA is the sector address for Sector Erase.
2. Address bits A16–A21 are don't cares during unlock cycles in the command sequence.

**Figure 14. Chip/Sector Erase Operations**

## AC CHARACTERISTICS

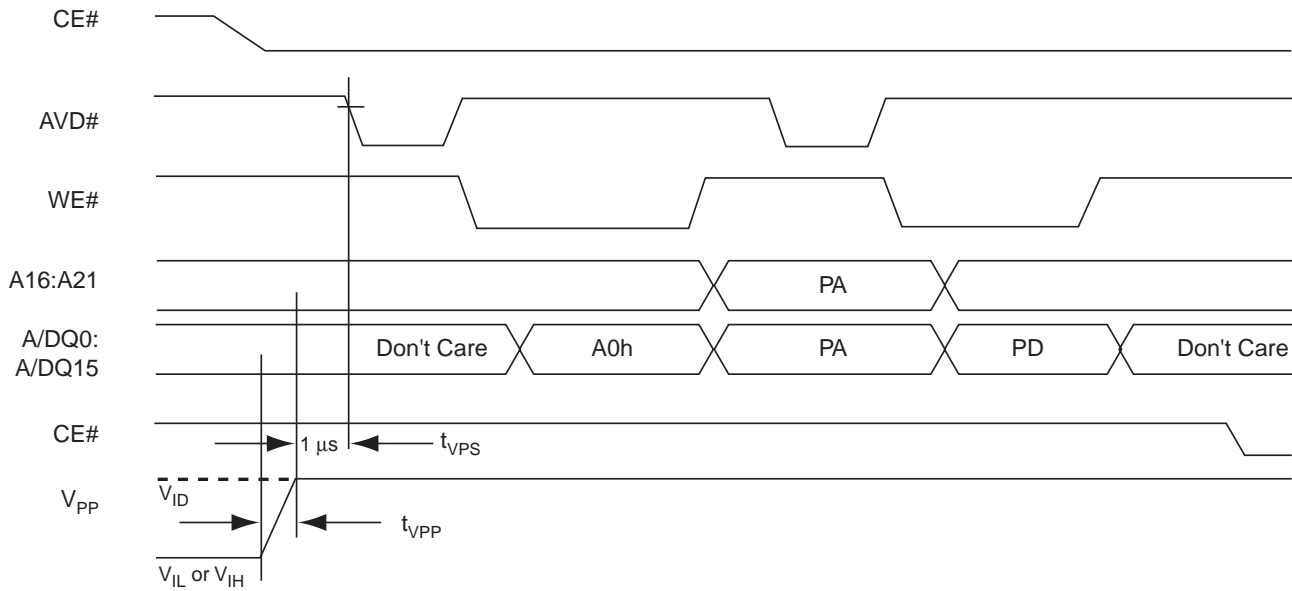
**Notes:**

1.  $V_{PP}$  can be left high for subsequent programming pulses.
2. Use setup and hold times from conventional program operation.
3. Sectors must be unlocked using the Sector Lock/Unlock command sequence prior to raising  $V_{PP}$  to  $V_{ID}$ .

**Figure 15. Accelerated Unlock Bypass Programming Timing**

AC CHARACTERISTICS

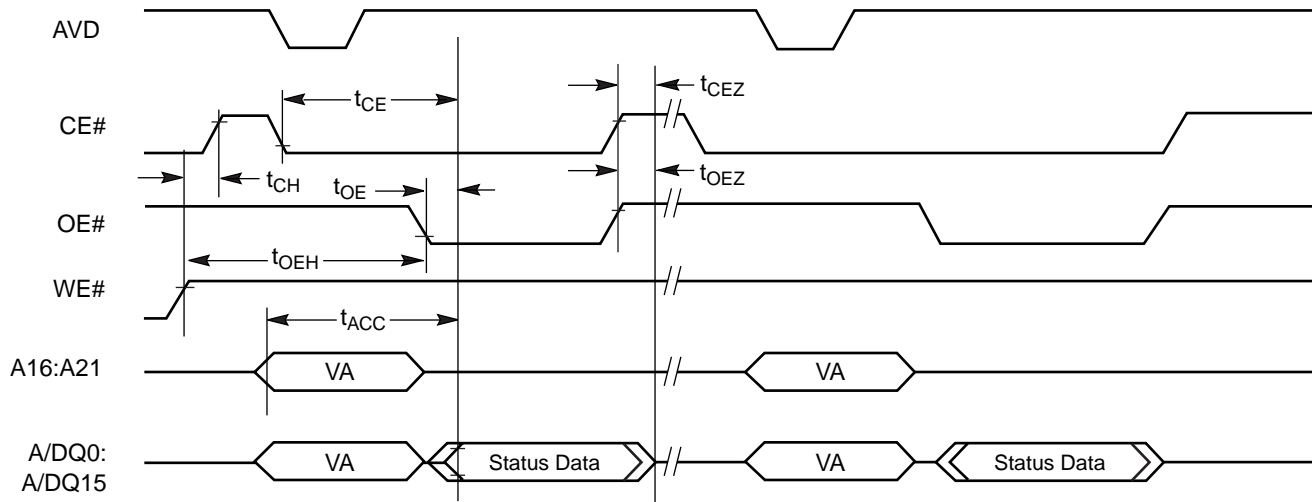

Notes:

1. All status reads are asynchronous.
2. VA = Valid Address. Two read cycles are required to determine status. When the Embedded Algorithm operation is complete, and Data# Polling will output true data.

Figure 16. Data# Polling Timings (During Embedded Algorithm)

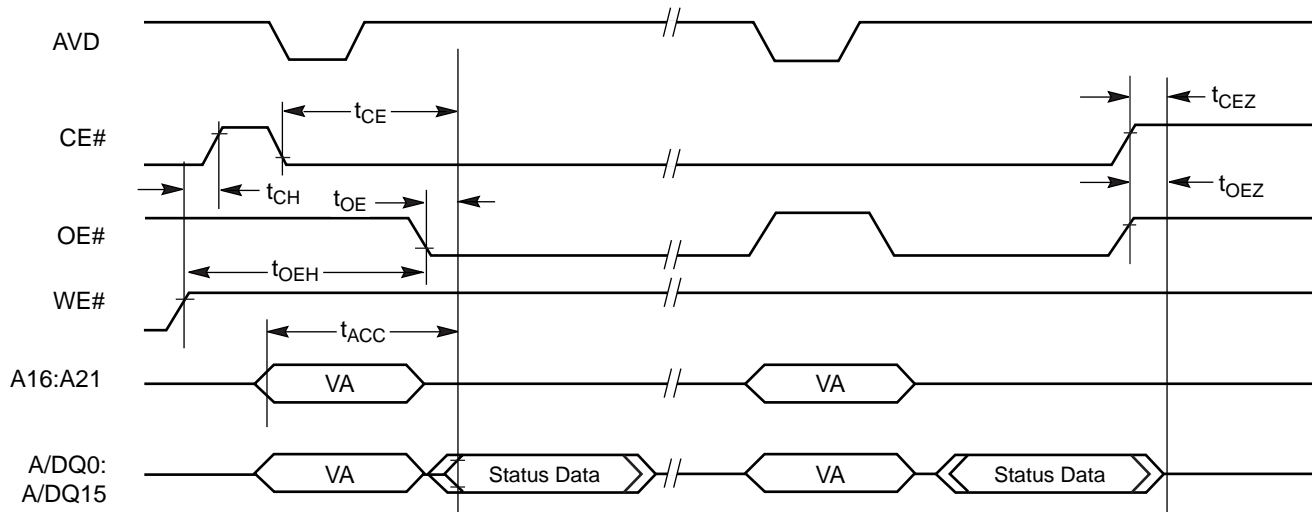

Notes:

1. All status reads are asynchronous.
2. VA = Valid Address. Two read cycles are required to determine status. When the Embedded Algorithm operation is complete, the toggle bits will stop toggling.

Figure 17. Toggle Bit Timings (During Embedded Algorithm)

## AC CHARACTERISTICS

Address boundary occurs every 64 words, beginning at address 00003Eh: 00007Eh, 0000BEh, etc.) Address 000000h is also a boundary crossing.

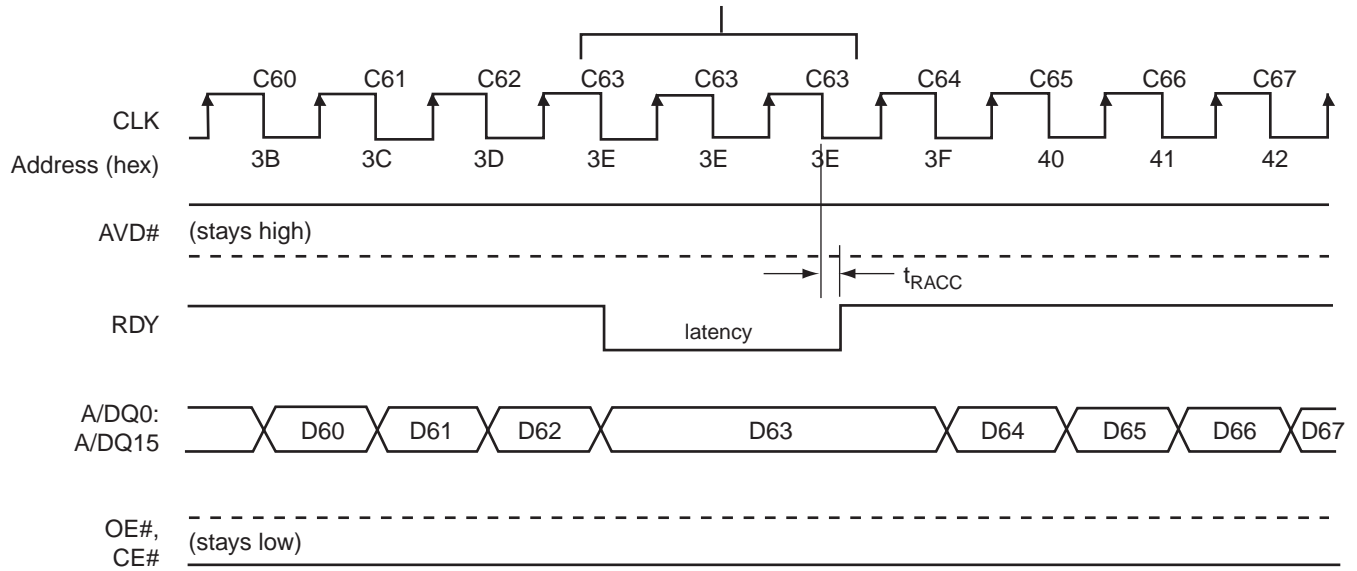

**Notes:**

1. Cxx indicates the clock that triggers Dxx on the outputs; for example, C60 triggers D60.
2. If PS is enabled, RDY will be low for an additional cycle prior to the boundary crossing latency.

**Figure 18. Latency with Boundary Crossing**

AC CHARACTERISTICS

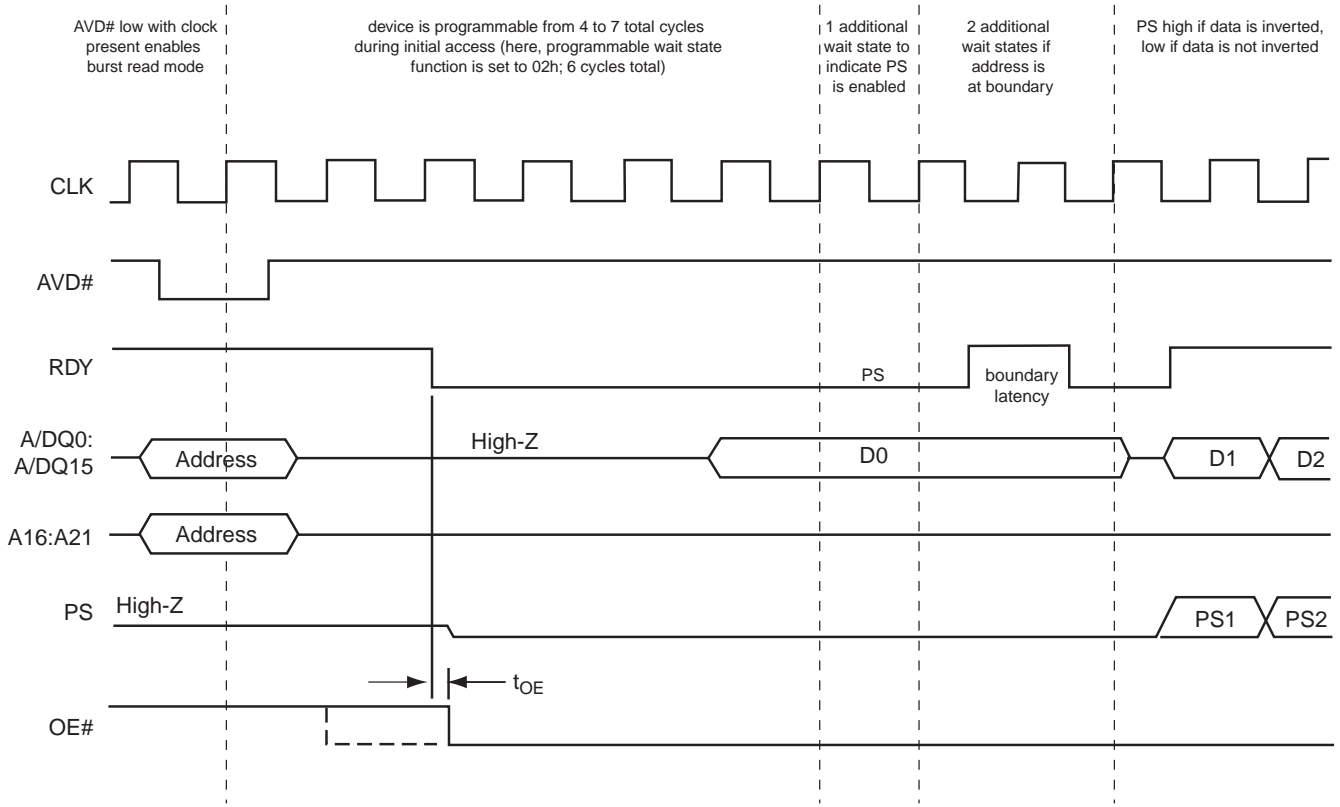

**Note:** Devices should be programmed with wait states as discussed in the “Programmable Wait State” section on page 10.

**Figure 19. Initial Access with Power Saving (PS) Function and Address Boundary Latency**

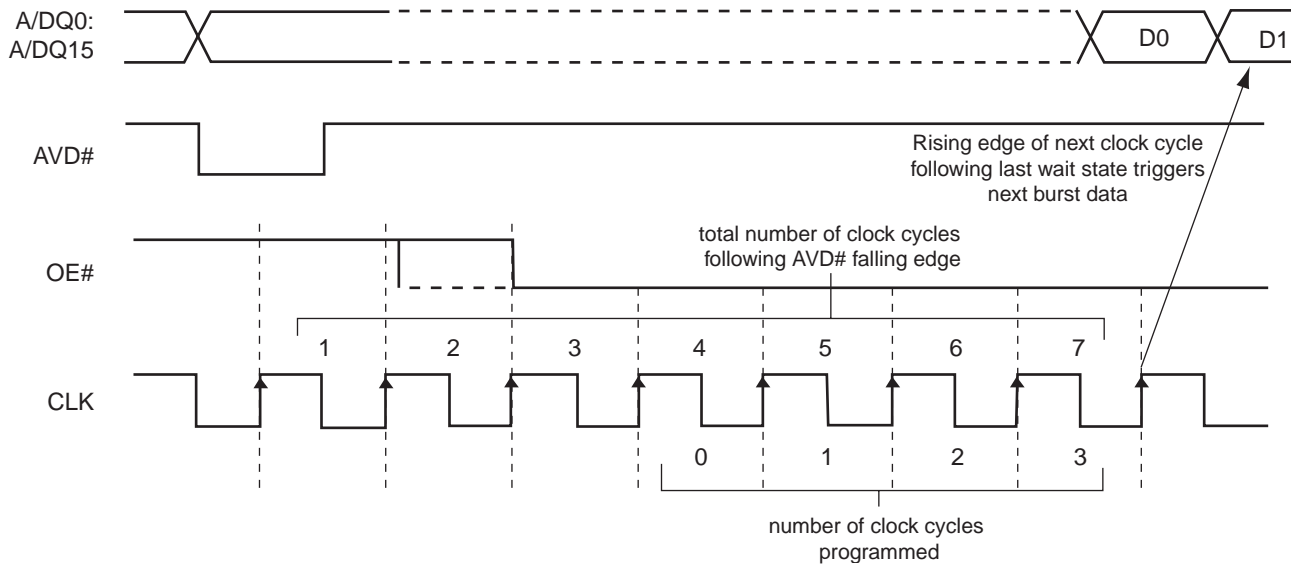

## AC CHARACTERISTICS

**Wait State Decoding Addresses:**

A13, A12 = "11" ⇒ 3 programmed, 7 total

A13, A12 = "10" ⇒ 2 programmed, 6 total

A13, A12 = "01" ⇒ 1 programmed, 5 total

A13, A12 = "00" ⇒ 0 programmed, 4 total

**Note:** Figure assumes that PS is not enabled, and address D0 is not at an address boundary.

**Figure 20. Example of Five Wait States Insertion (Non-Handshaking Device)**

AC CHARACTERISTICS

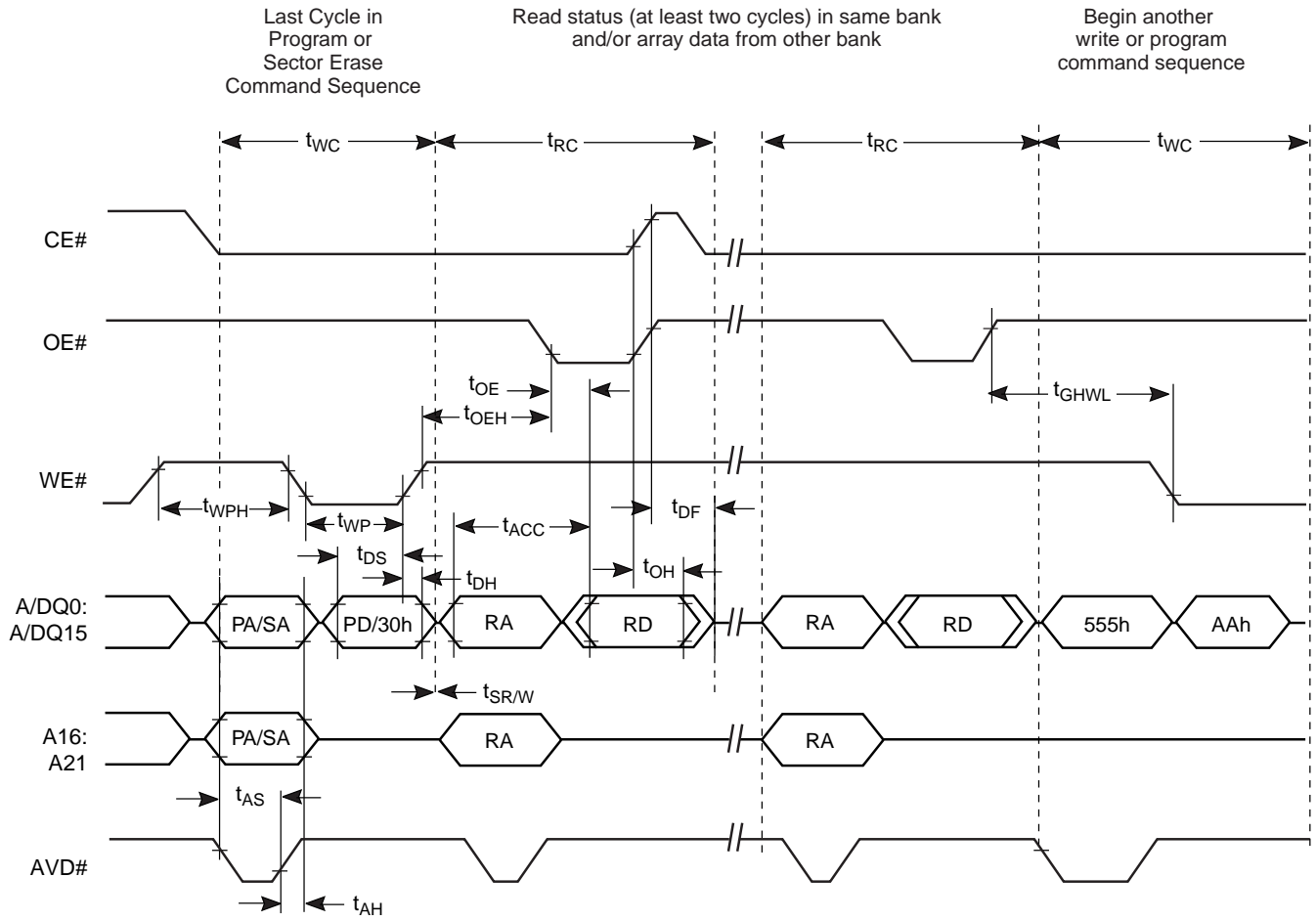

**Note:** Breakpoints in waveforms indicate that system may alternately read array data from the “non-busy bank” while checking the status of the program or erase operation in the “busy” bank. The system should read status twice to ensure valid information.

Figure 21. Back-to-Back Read/Write Cycle Timings

**ERASE AND PROGRAMMING PERFORMANCE**

Parameter		Typ (Note 1)	Max (Note 2)	Unit	Comments
Sector Erase Time	32 Kword	1.5	15	s	Excludes 00h programming prior to erasure (Note 4)
	4 Kword	0.3	5		
Chip Erase Time		194		s	
Word Programming Time		11.5	360	$\mu$ s	Excludes system level overhead (Note 5)
Accelerated Word Programming Time		4	210	$\mu$ s	
Chip Programming Time (Note 3)		48	144	s	Excludes system level overhead (Note 5)
Accelerated Chip Programming Time		16	48	s	

**Notes:**

1. Typical program and erase times assume the following conditions: 25°C, 1.8 V  $V_{CC}$ , 1 million cycles. Additionally, programming typicals assume checkerboard pattern.
2. Under worst case conditions of 90°C,  $V_{CC} = 1.8$  V, 100,000 cycles.
3. The typical chip programming time is considerably less than the maximum chip programming time listed.
4. In the pre-programming step of the Embedded Erase algorithm, all words are programmed to 00h before erasure.
5. System-level overhead is the time required to execute the two- or four-bus-cycle sequence for the program command. See Table 4 for further information on command definitions.
6. The device has a minimum erase and program cycle endurance of 1 million cycles.

**DATA RETENTION**

Parameter	Test Conditions	Min	Unit
Minimum Pattern Data Retention Time	150°C	10	Years
	125°C	20	Years

PHYSICAL DIMENSIONS\*

FDE048—48-Pin Fine-Pitch Ball Grid Array (FBGA) 11 x 10 mm package

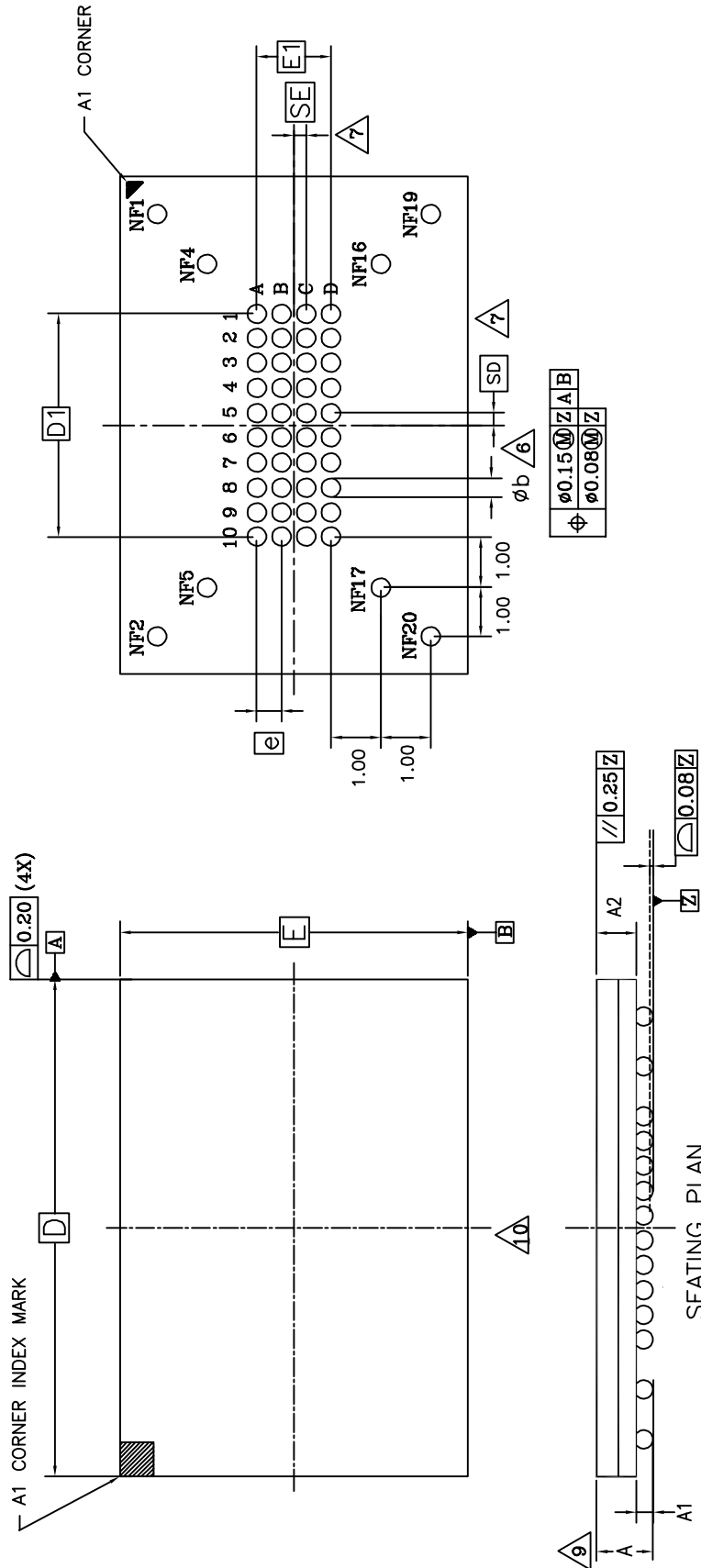

Dwg Rev AF; 4/00

\* For reference only. BSC is an ANSI standard for Basic Space Centering

PHYSICAL DIMENSIONS

FDE048—48-Pin Fine-Pitch Ball Grid Array (FBGA) 11 x 10 mm (continued)

PACKAGE	FDE 048			NOTE
JEDEC	N/A			
	11.00mmx10.00mm PACKAGE			
SYMBOL	MIN	NOM	MAX	NOTE
A	—	—	1.20	OVERALL THICKNESS
A1	0.20	—	—	BALL HEIGHT
A2	0.84	—	0.94	BODY THICKNESS
$\square$ D	10.00 BSC			BODY SIZE
$\square$ E	11.00 BSC			BODY SIZE
$\square$ D1	4.50 BSC			BALL FOOTPRINT
$\square$ E1	1.50 BSC			BALL FOOTPRINT
MD	10			ROW MATRIX SIZE D DIRECTION
ME	4			ROW MATRIX SIZE E DIRECTION
N	48			TOTAL BALL COUNT
b	0.25	0.30	0.35	BALL DIAMETER
$\square$ e	0.50 BSC			BALL PITCH
$\square$ SD/ $\square$ SE	0.25 BSC			SOLDER BALL PLACEMENT

NOTES:

1. DIMENSIONING AND TOLERANCING PER ASME Y14.5M-1994 .
2. ALL DIMENSIONS ARE IN MILLIMETERS .
3. BALL POSITION DESIGNATION PER JEDEC 95-1, SPP-010 .
4.  $\square$ e REPRESENTS THE SOLDER BALL GRID PITCH .
5. SYMBOL "MD" IS THE BALL ROW MATRIX SIZE IN THE "D" DIRECTION. SYMBOL "ME" IS THE BALL COLUMN MATRIX SIZE IN THE "E" DIRECTION. N IS THE MAXIMUM NUMBER OF SOLDER BALLS FOR MATRIX SIZE MD x ME .
6. DIMENSION "b" IS MEASURED AT THE MAXIMUM BALL DIAMETER IN A PLANE PARALLEL TO DATUM Z .
7. SD AND SE ARE MEASURED WITH RESPECT TO DATUMS A AND B AND DEFINE THE POSITION OF THE CENTER SOLDER BALL IN THE OUTER ROW. WHEN THERE IS AN ODD NUMBER OF SOLDER BALLS IN THE OUTER ROW PARALLEL TO THE D OR E DIMENSION, RESPECTIVELY, SD OR SE = 0.000 WHEN THERE IS AN EVEN NUMBER OF SOLDER BALLS IN THE OUTER ROW, SD OR SE =  $\square{e/2}$
8. "+" IN THE PACKAGE DRAWING INDICATE THE THEORETICAL CENTER OF DEPOPULATED BALLS.
9. FOR PACKAGE THICKNESS A IS THE CONTROLLING DIMENSION.
10. A1 CORNER TO BE IDENTIFIED BY CHAMFER, INK MARK, METALLIZED MARKINGS INDENTATION OR OTHER MEANS.

## REVISION SUMMARY

### Revision A (June 20, 2000)

initial release.

### Revision A+1 (November 27, 2000)

#### Global

Deleted all references to non-handshaking option.

#### Ordering Information

Added "H" designator to device package marking.

#### Requirements for Synchronous (Burst) Read Operation

Changed the latency for address boundary crossing to two cycles for all speeds of operation.

#### Autoselect Command Sequence

Corrected autoselect data for handshaking to 0041h. Added table to section for feature clarification.

#### Chip Erase Command Sequence

Corrected the command sequence length during unlock bypass mode from four cycles to two.

#### DC Characteristics table

Added specification for active burst mode current with OE# high,  $I_{CCB2}$ . Original  $I_{CCB}$  specification is now named  $I_{CCB1}$ .

#### Program Command Sequence, Accelerated Program Operation

Added text indicating that sectors must be unlocked prior to raising  $V_{PP}$  to  $V_{ID}$ .

#### Table 4, Command Definitions

Corrected autoselect data for handshaking to 0041h.

#### AC Characteristics

- *Burst Mode Read figures (40 and 54 MHz)*: Corrected RDY waveform to indicate behavior when PS is enabled and when RDY is in the high-impedance stage.

*Accelerated Unlock Bypass Programming Timing figure*: Modified Note 3 to indicate that sectors must be unlocked prior to raising  $V_{PP}$  to  $V_{ID}$ .

*Latency with Boundary Crossing (40 MHz) figure*: Deleted figure; all speed options have a two-cycle latency.

*Initial Access with Power Saving (PS) and Address Boundary Latency figure*: Modified to show that two-cycle latency is present, and that RDY is high for a portion of the boundary latency.

### Revision A+2 (November 30, 2000)

#### Figure 11, Asynchronous Mode Read

Corrected endpoint for  $t_{AAVDS}$  specification.

#### Figure 17, Toggle Bit Timings (During Embedded Algorithm)

Corrected OE# waveform during second VA (valid address) period.

### Revision A+3 (December 21, 2000)

#### Figure 9, Burst Mode Read (54 MHz) and Figure 10, Burst Mode Read (40 MHz)

Corrected RDY waveform.

#### Trademarks

Copyright © 2000 Advanced Micro Devices, Inc. All rights reserved.

AMD, the AMD logo, and combinations thereof are registered trademarks of Advanced Micro Devices, Inc.

Product names used in this publication are for identification purposes only and may be trademarks of their respective companies.