

**5-CHANNEL MOTOR DRIVER FOR DVD PLAYER****AM5665****General Description**

The AM5665 is a 5-channel BTL driver IC, in which two channels drive DC motor, two channels with current feedback drive the coils, such as the focus and the tracking actuator of DVD player, and the other one channel drives the bi-direction DC motor for tray.

The AM5665 is available in standard HSOP-28 package.

**Features**

- 2-Channel DC Motor BTL Driver
- 2-Channel BTL Driver for Coils with Current Feedback
- 1-Channel Forward/Reverse Control DC Motor Driver
- Built-in Thermal Shutdown Circuit
- Built-in Standby Circuit
- Operating Voltage: 4.5 to 8.0V

**Applications**

- DVD Player



Figure 1. Package Type of AM5665



**5-CHANNEL MOTOR DRIVER FOR DVD PLAYER**

**AM5665**

**Pin Configuration**

M Package  
(HSOP-28)

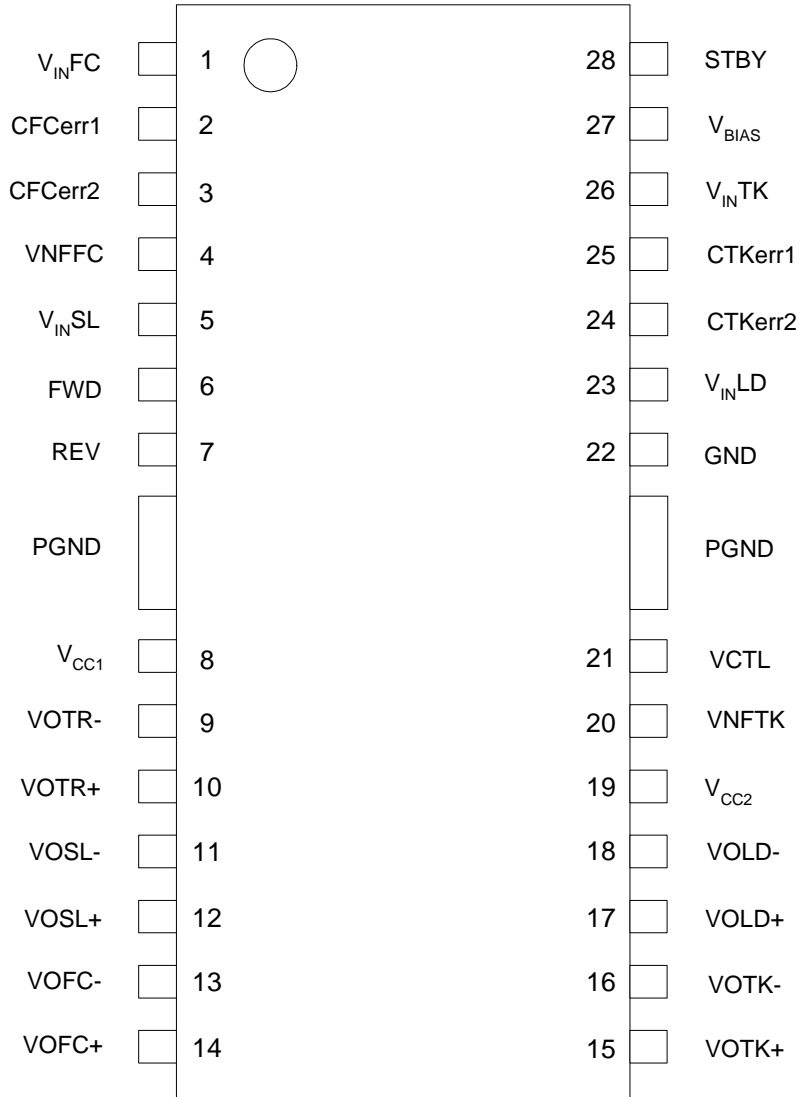

Figure 2. Pin Configuration of AM5665 (Top View)

**5-CHANNEL MOTOR DRIVER FOR DVD PLAYER****AM5665****Pin Description**

Pin Number	Pin Name	Function
1	V <sub>INFC</sub>	Focus driver input
2	CFCerr1	Capacitor connection 1 for the error amp filter of focus channel
3	CFCerr2	Capacitor connection 2 for the error amp filter of focus channel
4	VNFFC	Focus driver feedback pin
5	V <sub>INSL</sub>	Sled driver input
6	FWD	Tray driver forward input
7	REV	Tray driver reverse input
8	V <sub>CC1</sub>	Power supply 1
9	VOTR-	Tray driver output (-)
10	VOTR+	Tray driver output (+)
11	VOSL-	Sled driver output (-)
12	VOSL+	Sled driver output (+)
13	VOFC-	Focus driver output (-)
14	VOFC+	Focus driver output (+)
15	VOTK+	Tracking driver output (+)
16	VOTK-	Tracking driver output (-)
17	VOLD+	Loading driver output (+)
18	VOLD-	Loading driver output (-)
19	V <sub>CC2</sub>	Power supply 2
20	VNFTK	Tracking driver feedback pin
21	VCTL	Tray driver speed control pin
22	GND	Ground
23	V <sub>INLD</sub>	Loading driver input
24	CTKerr2	Capacitor connection 2 for the error amp filter of tracking channel
25	CTKerr1	Capacitor connection 1 for the error amp filter of tracking channel
26	V <sub>INTK</sub>	Tracking driver input
27	V <sub>BIAS</sub>	VREF input pin
28	STBY	Stand-by control



**5-CHANNEL MOTOR DRIVER FOR DVD PLAYER**

**AM5665**

**Functional Block Diagram**

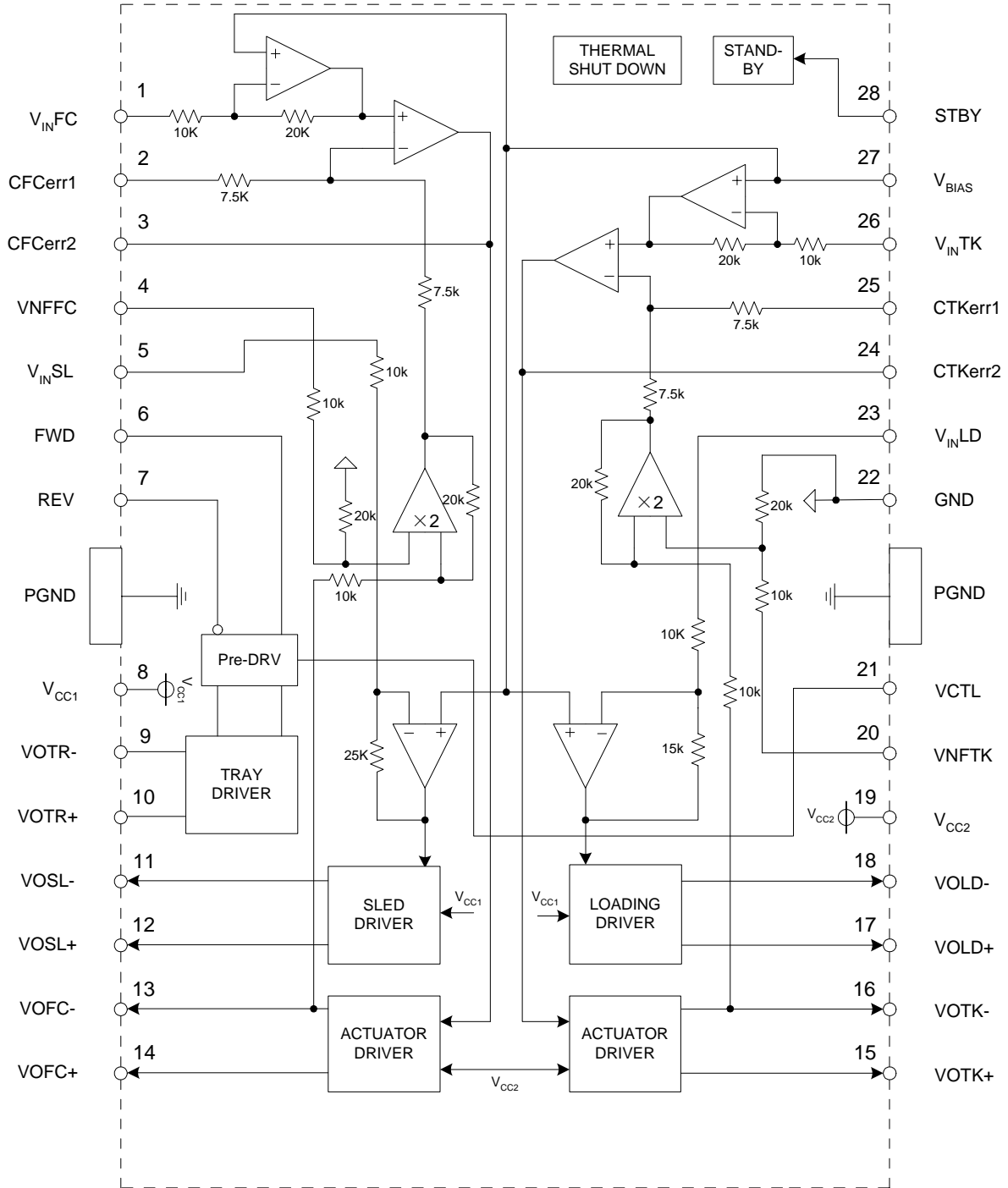

Figure 3. Functional Block Diagram of AM5665



**5-CHANNEL MOTOR DRIVER FOR DVD PLAYER**

**AM5665**

**Ordering Information**

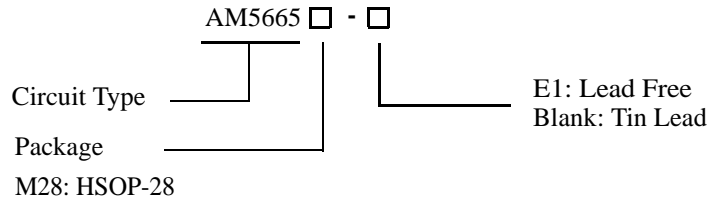

Package	Temperature Range	Part Number		Marking ID		Packing Type
		Tin Lead	Lead Free	Tin Lead	Lead Free	
HSOP-28	0 to 70°C	AM5665M28	AM5665M28-E1	AM5665M28	AM5665M28-E1	Tube

BCD Semiconductor's Pb-free products, as designated with "E1" suffix in the part number, are RoHS compliant.

**Absolute Maximum Ratings (Note 1)**

Parameter	Symbol	Value	Unit
Supply Voltage	$V_{CC1,2}$	9.6	V
ESD (HBM)	ESD	2000	V
Power Dissipation	$P_D$	1.7	W
Storage Temperature Range	$T_{STG}$	-55 to +150	°C

Note 1: Stresses greater than those listed under "Absolute Maximum Ratings" may cause permanent damage to the device. These are stress ratings only, and functional operation of the device at these or any other conditions beyond those indicated under "Recommended Operating Conditions" is not implied. Exposure to "Absolute Maximum Ratings" for extended periods may affect device reliability.

**Recommended Operating Conditions**

Parameter	Symbol	Min	Max	Unit
Supply Voltage	$V_{CC1}$	4.5	8.0	V
	$V_{CC2}$	4.5 to $V_{CC1}$		V
Operating Temperature	$T_A$	0	70	°C



**5-CHANNEL MOTOR DRIVER FOR DVD PLAYER**

**AM5665**

**Electrical Characteristics**

( $T_A=25^\circ\text{C}$ ,  $V_{CC1}=V_{CC2}=5\text{V}$ ,  $V_{BIAS}=1.65\text{V}$ ,  $R_{L1}=R_{L2}=8\Omega$ ,  $R_{L3}=R_{L4}=12\Omega$ ,  $R_{L5}=45\Omega$ , unless otherwise specified.)

Parameter	Symbol	Conditions	Min	Typ	Max	Unit
Quiescent Current	$I_{CC}$	No load		18	27	mA
Standby Current	$I_{ST}$			2.3	4.0	mA
Standby on Voltage	$V_{STON}$		0		0.5	V
Standby off Voltage	$V_{STOFF}$		2.0		5.0	V
<b>Actuator Driver</b>						
Output Offset Current	$I_{OO1,2}$		-10		+10	mA
Maximum Output Voltage	$V_{O1,2MAX}$	$V_{IN}=V_{BIAS} \pm 1.5\text{V}$	3.3	3.5		V
Transmission Gain	gm	$V_{IN}=V_{BIAS} \pm 0.2\text{V}$	1.3	1.5	1.7	A/V
<b>Sled Motor Driver</b>						
Output Offset Voltage	$V_{OOSL}$		-100		100	mV
Maximum Output Voltage	$V_{O3MAX}$	$V_{IN}=V_{BIAS} \pm 1.5\text{V}$	3.3	3.5		V
Closed-Loop Voltage Gain	$G_{VSL}$	$V_{IN}=V_{BIAS} \pm 0.2\text{V}$	18.0	20.0	22.0	dB
<b>Loading Motor Driver</b>						
Output Offset Voltage	$V_{OOLD}$		-50		50	mV
Maximum Output Voltage	$V_{O4MAX}$	$V_{IN}=V_{BIAS} \pm 5.5\text{V}$	3.3	3.5		V
Closed-Loop Voltage Gain	$G_{VLD}$	$V_{IN}=V_{BIAS} \pm 0.2\text{V}$	14	16	18	dB
Gain Error by Polarity	$\Delta G_{VLD}$		0	1	2	dB
<b>Tray Motor Driver</b>						
Output Offset Voltage	$V_{OOTR}$	$R_{L5}=45\Omega$ , $R_{VCTL}=0\Omega$	-50	0	50	mV
Maximum Output Voltage	$V_{O5MAX1}$	$R_{L5}=45\Omega$ , $R_{VCTL}=400\Omega$	1.3	1.5	1.7	V
	$V_{O5MAX2}$	$R_{L5}=45\Omega$ , $R_{VCTL}=0\Omega$	3.8	4.0	4.2	V
Input High Level Voltage	$V_{IH}$		2.0		5.0	V
Input Low Level Voltage	$V_{IL}$		0		0.8	V



**5-CHANNEL MOTOR DRIVER FOR DVD PLAYER**

**AM5665**

**Test Circuit**

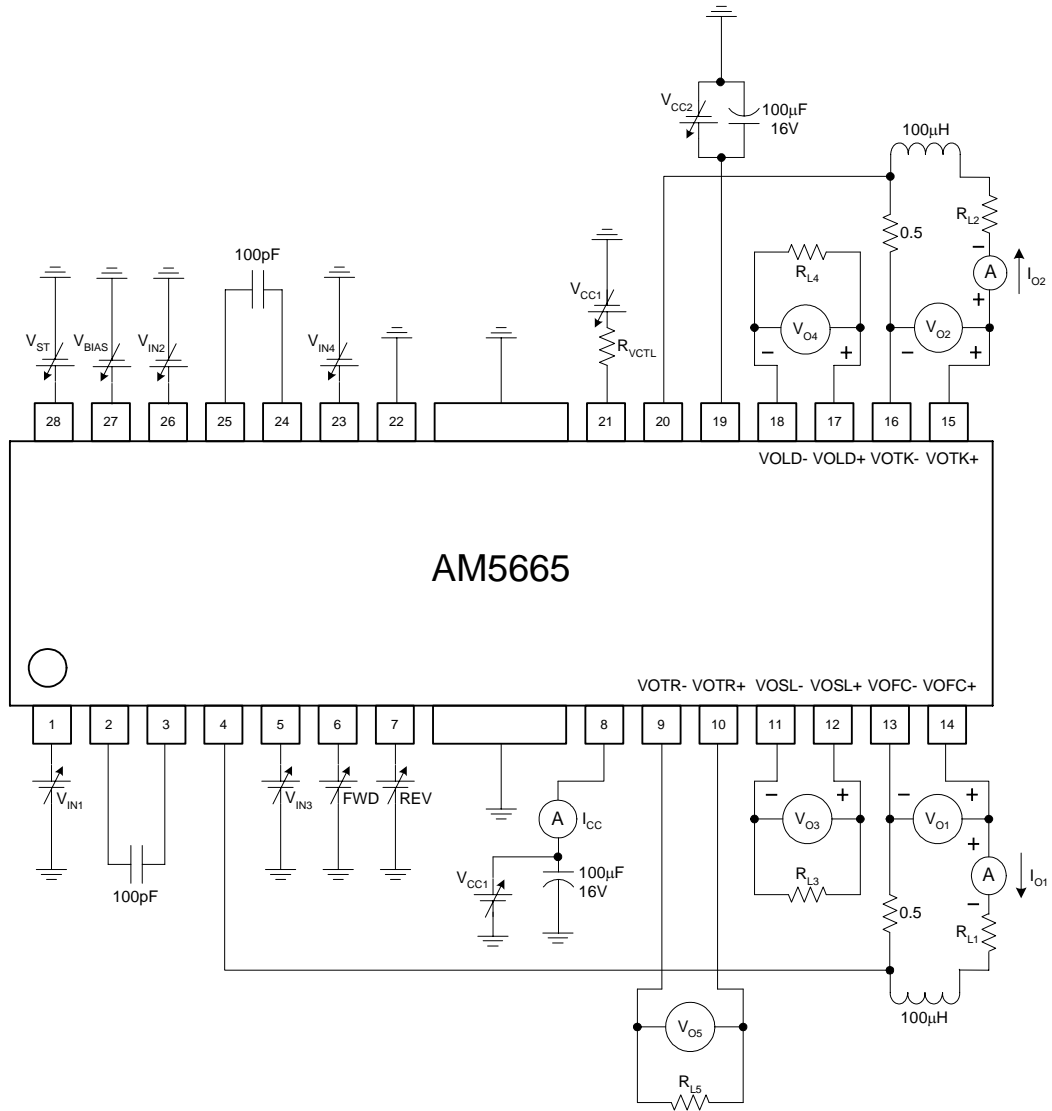

Figure 4. Test Circuit of AM5665



**5-CHANNEL MOTOR DRIVER FOR DVD PLAYER**

**AM5665**

**Typical Performance Characteristics (Note 2)**

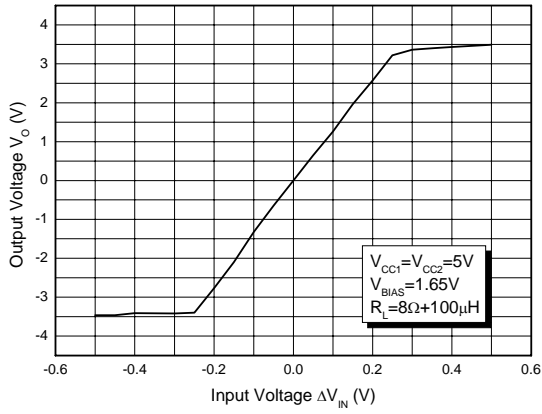

Figure 5. Driver I/O Characteristics (Focus)

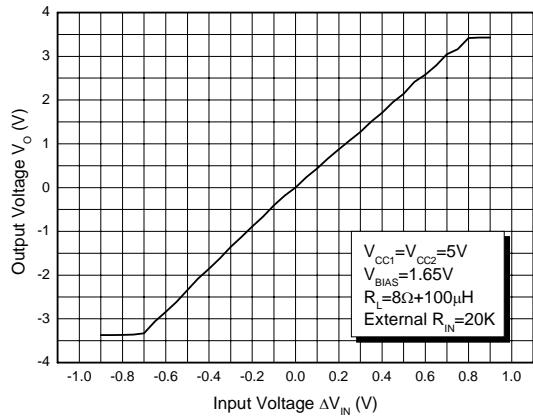

Figure 6. Driver I/O Characteristics (Focus)

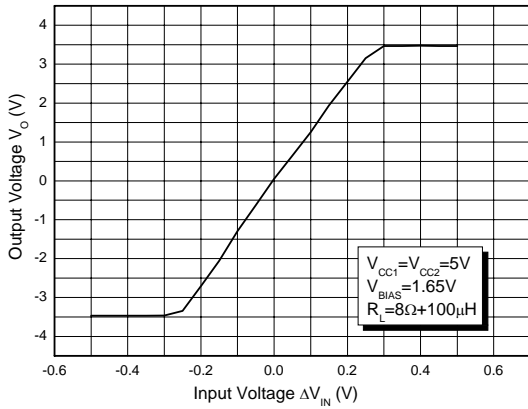

Figure 7. Driver I/O Characteristics (Track)

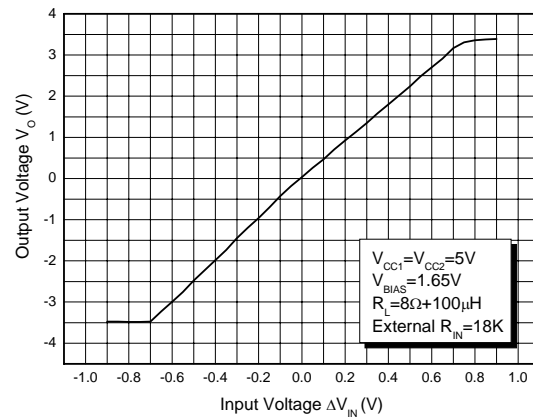

Figure 8. Driver I/O Characteristics (Track)





**5-CHANNEL MOTOR DRIVER FOR DVD PLAYER**

**AM5665**

**Typical Performance Characteristics (Continued)**

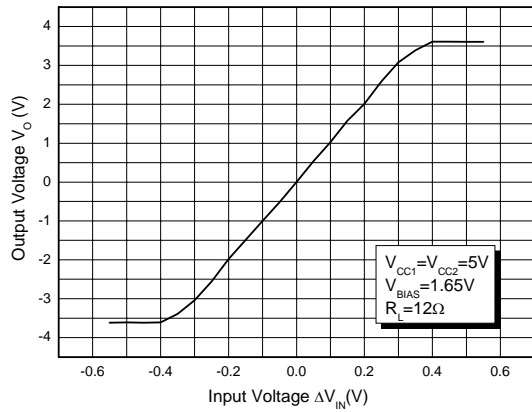

Figure 9. Driver I/O Characteristics (Sled)

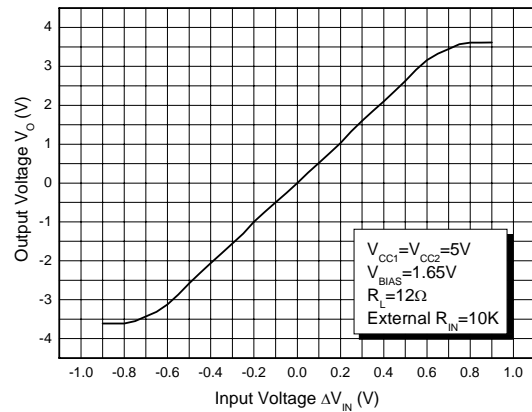

Figure 10. Driver I/O Characteristics (Sled)

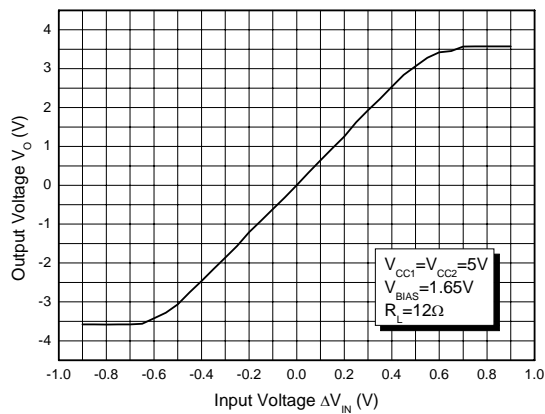

Figure 11. Driver I/O Characteristics (Loading)

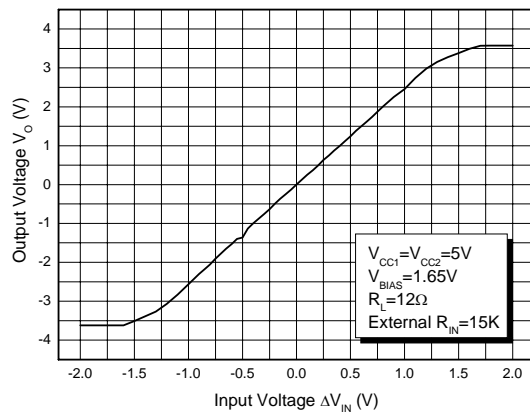

Figure 12. Driver I/O Characteristics (Loading)



**5-CHANNEL MOTOR DRIVER FOR DVD PLAYER**

**AM5665**

**Typical Performance Characteristics (Continued)**

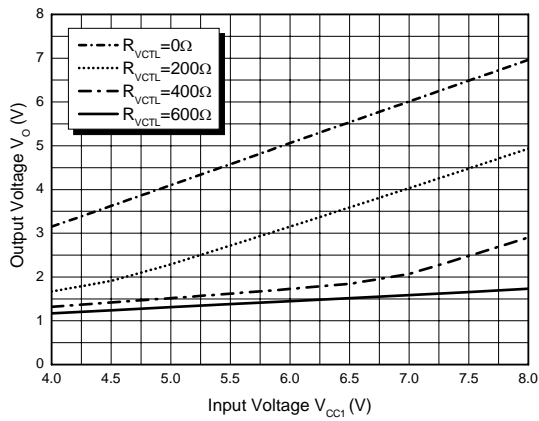

Figure 13. Tray Speed Control Characteristics

Note 2:

For the above figures 6, 8, 10, 12, please refer to the following "Typical Application" section.



**5-CHANNEL MOTOR DRIVER FOR DVD PLAYER**

**AM5665**

**Typical Application**

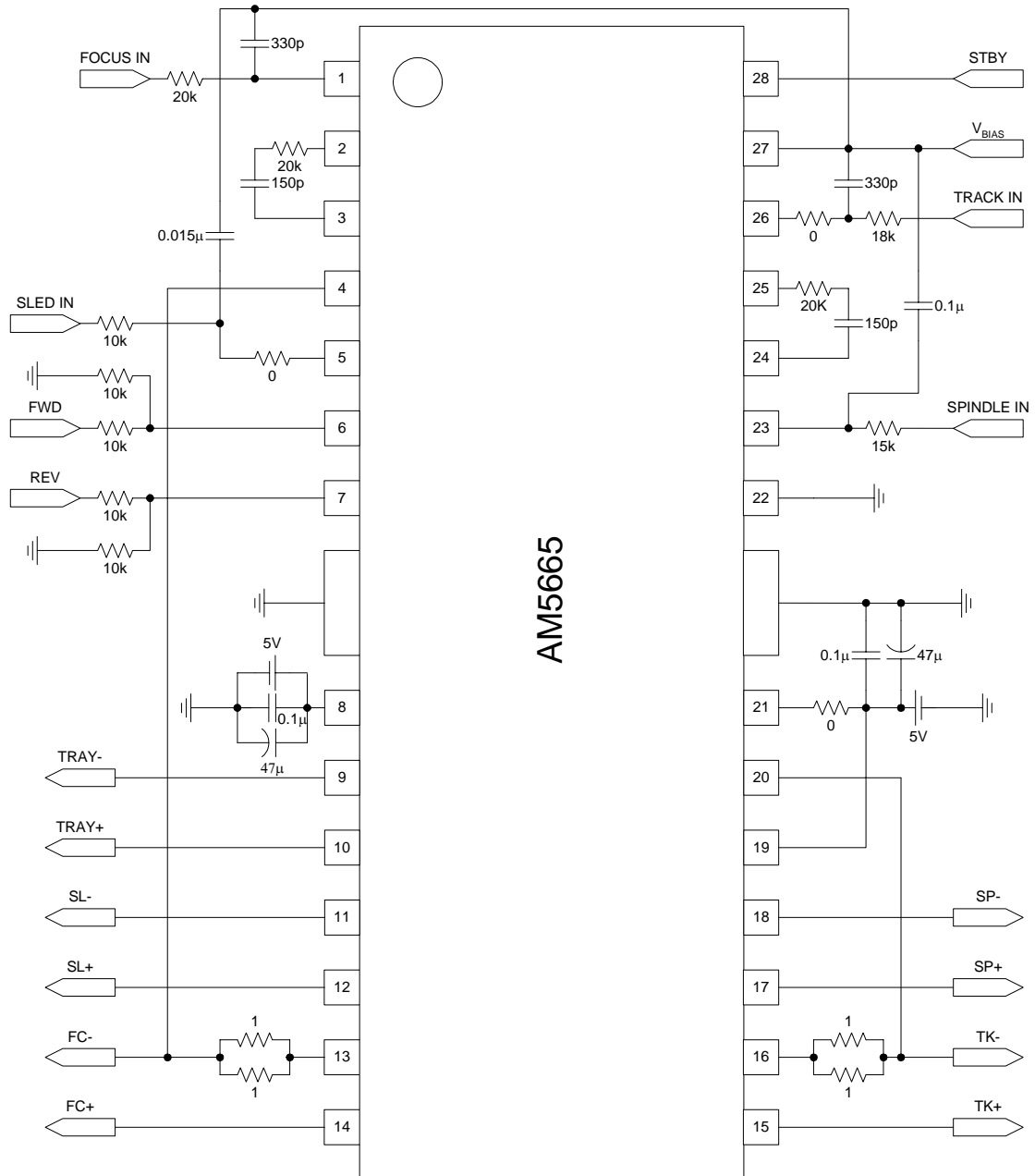

Figure 14. Typical Application of AM5665 in DVD Player



**5-CHANNEL MOTOR DRIVER FOR DVD PLAYER**

**AM5665**

**Application Information**

This application information is only for the Tray Motor Driver section.

**Tray Motor Driver**

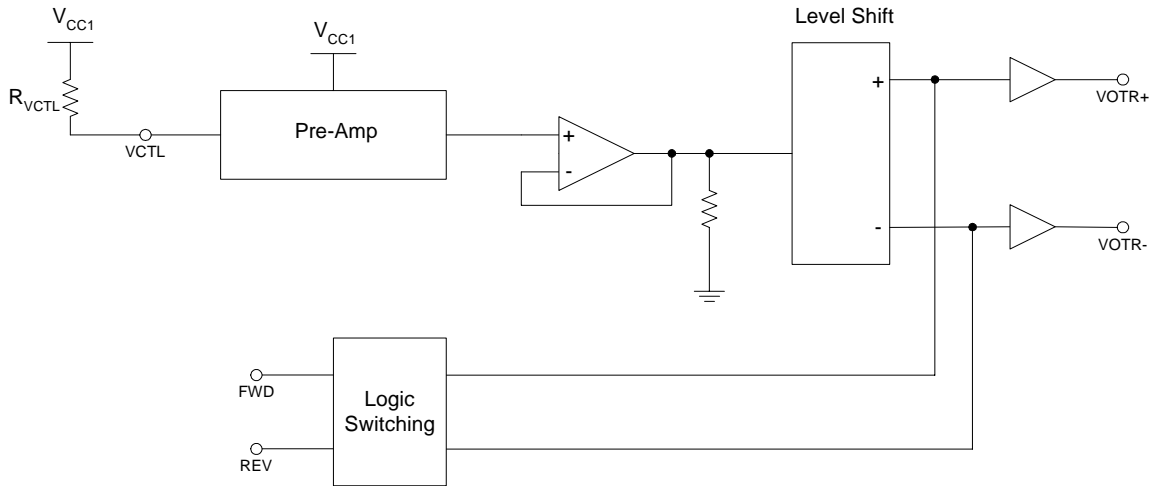

Figure 15. Tray Motor Driver Control Illustration

**Output Status Control Table**

Input		Output		
FWD	REV	VOTR+	VOTR-	Status
High	High	Low	Low	Break
High	Low	High	Low	Forward
Low	High	Low	High	Reverse
Low	Low	Open	Open	Standby

**Tray Motor Speed Control**

The amplitude of output voltage depends on VCTL (pin 21). Connect a resistor between VCTL (pin 21) and V<sub>CC1</sub>, and you can obtain different output voltages for tray driver by changing the value of R<sub>VCTL</sub>. (See Figure 4.)



**5-CHANNEL MOTOR DRIVER FOR DVD PLAYER**

**AM5665**

**Mechanical Dimensions**

**HSOP-28**

**Unit: mm(inch)**

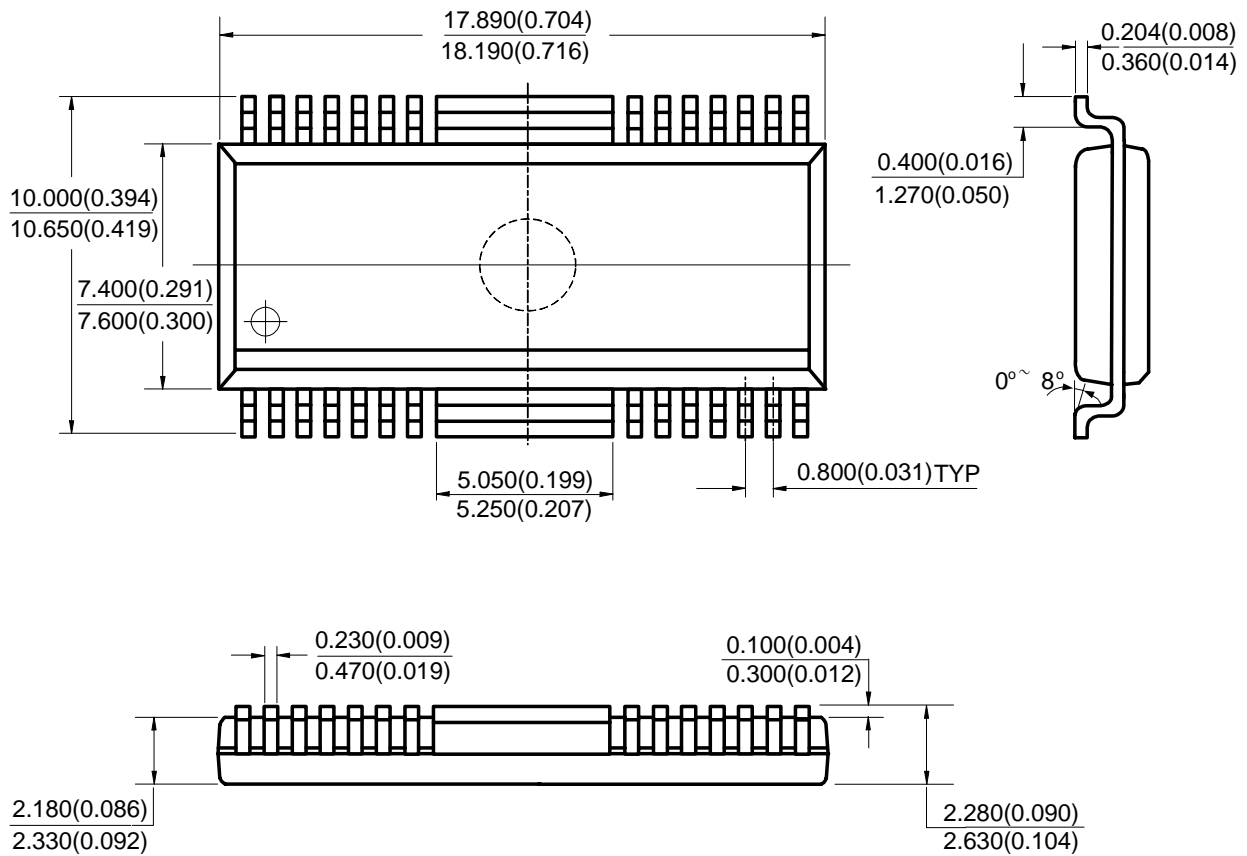



BCD Semiconductor Manufacturing Limited

<http://www.bcdsemi.com>

---

**BCD Semiconductor Corporation**

3170 De La Cruz Blvd, Suite # 105 Santa Clara, CA 95054-2411, U.S.A

Tel: +1-408-988 6388, Fax: +1-408-988 6386

**Shanghai SIM-BCD Semiconductor Manufacturing Co., Ltd.**

800 Yi Shan Road, Shanghai 200233, PRC

Tel: +86-21-6485-1491, Fax: +86-21-5450-0008

**Advanced Analog Circuits (Shanghai) Corporation**

8F, B Zone, 900 Yi Shan Road, Shanghai 200233, PRC

Tel: +86-21-6495 9539, Fax: +86-21-6485 9673

**BCD Semiconductor (Taiwan) Company Limited**

Room 2210, 22nd Fl, 333, Keelung Road, Sec. 1, TaiPei (110), Taiwan

Tel: +886-2-2758 6828, Fax: +886-2-2758 6892

**IMPORTANT NOTICE**

BCD Semiconductor Manufacturing Limited reserves the right to make changes without further notice to any products or specifications herein. BCD Semiconductor Manufacturing Limited does not assume any responsibility for use of any its products for any particular purpose, nor does BCD Semiconductor Manufacturing Limited assume any liability arising out of the application or use of any its products or circuits. BCD Semiconductor Manufacturing Limited does not convey any license under its patent rights or other rights nor the rights of others.