

**4-CHANNEL MOTOR DRIVER WITH POWER CONTROLLER****AM5901A****General Description**

The AM5901A is a 4-channel motor driver with power controller that includes the reset, battery charge and reduced voltage detection circuits required for portable CD/MP3/VCD players on a single chip.

This kind of IC is provided with lower startup voltage and power consumption than similar products, its driver block power supply uses on-chip switching regulator, making this component an ideal choice for low-power sets. It is used in mini portable compact disc players (CDP), portable mini disc players (MD), disc-man or other portable compact disc media.

The AM5901A is available in PQFP-44 and LQFP-44 packages.

Features

- 4-channel H-bridge Driver
- Built-in DC/DC Converter Control Circuit
- Built-in Reset Circuit
- Built-in Reduced Voltage Detection Circuit
- Built-in Battery Charging Circuit
- Built-in General-purpose Operational Amplifier
- Built-in Thermal Shutdown Circuit
- Low Power Consumption

Applications

- Portable Compact Disc Player (CDP)
- Portable Mini Disc Player
- Portable Disc-man
- Portable CD/MP3/VCD
- Other Portable Compact Disc Media

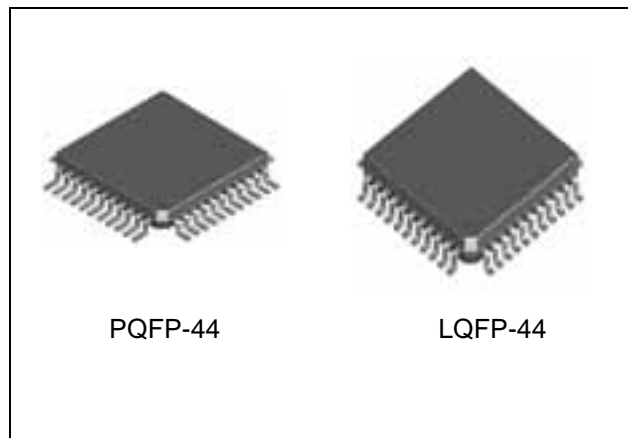

Figure 1. Package Types of AM5901A



4-CHANNEL MOTOR DRIVER WITH POWER CONTROLLER

AM5901A

Pin Configuration

F44 Package
(PQFP-44)

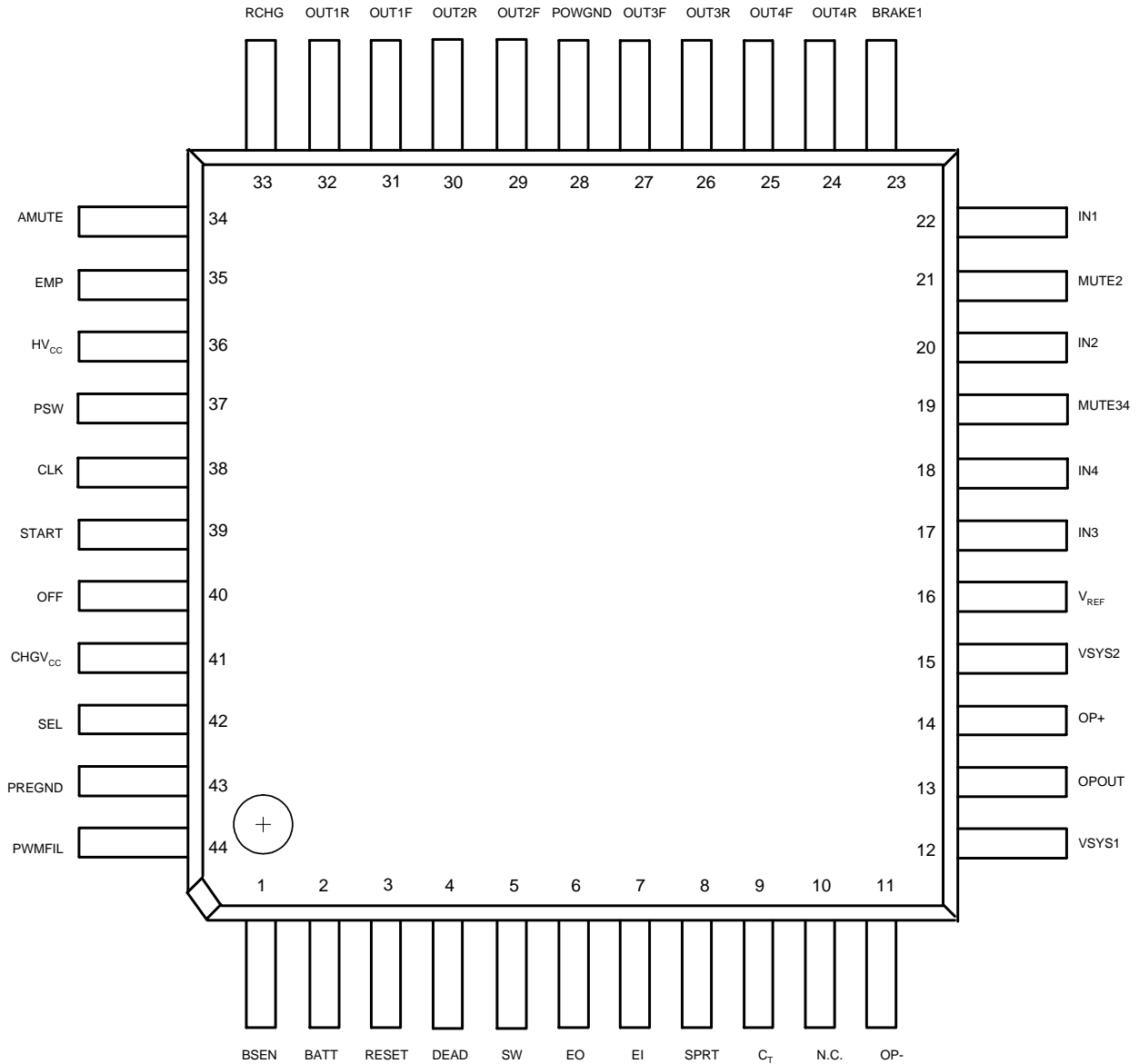

Figure 2. Pin Configuration of AM5901A (Top View)



4-CHANNEL MOTOR DRIVER WITH POWER CONTROLLER

AM5901A

Pin Configuration (Continued)

LF44 Packages
(LQFP-44)

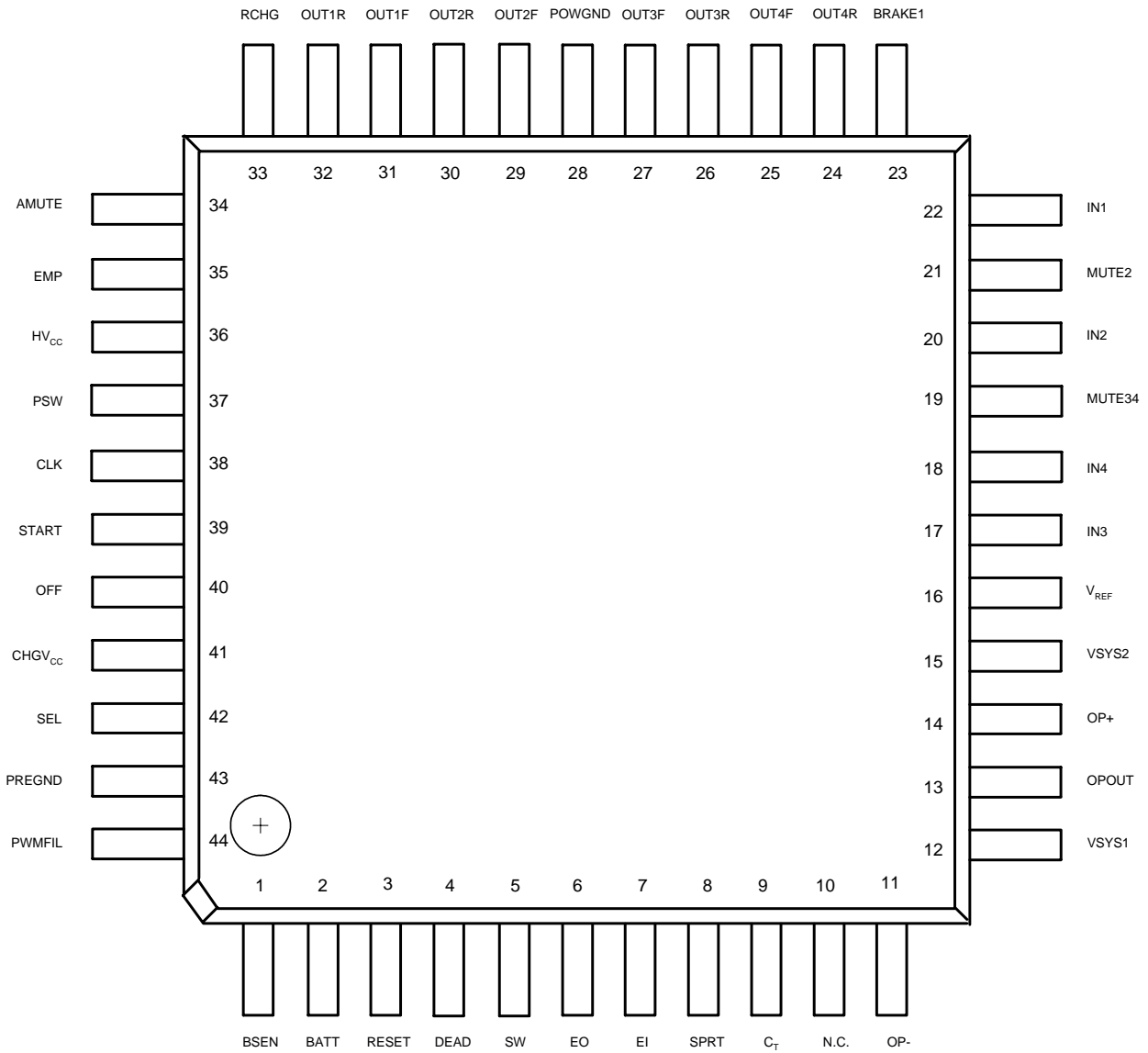

Figure 3. Pin Configuration of AM5901A (Top View)

**4-CHANNEL MOTOR DRIVER WITH POWER CONTROLLER****AM5901A****Pin Description**

Pin Number	Pin Name	Function
1	BSEN	Battery voltage monitor
2	BATT	Battery power supply input
3	RESET	Reset detection output
4	DEAD	Dead-time setting
5	SW	Booster transistor drive
6	EO	Error amplifier output
7	EI	Error amplifier input
8	SPRT	Short-circuit protection setting
9	C _T	Triangular wave output
10	N.C.	Nothing connected
11	OP-	Operational amplifier negative input
12	VSYS1	Control circuit power supply input
13	OPOUT	Operational amplifier output
14	OP+	Operational amplifier positive input
15	VSYS2	Pre-driver power supply input
16	V _{REF}	Reference power supply input
17	IN3	CH3 control signal input
18	IN4	CH4 control signal input
19	MUTE34	CH3/CH4 mute
20	IN2	CH2 control signal input
21	MUTE2	CH2 mute
22	IN1	CH1 control signal input
23	BRAKE1	CH1 brake
24	OUT4R	CH4 negative output
25	OUT4F	CH4 positive output
26	OUT3R	CH3 negative output
27	OUT3F	CH3 positive output
28	POWGND	Power unit power ground
29	OUT2F	CH2 positive output
30	OUT2R	CH2 negative output
31	OUT1F	CH1 positive output
32	OUT1R	CH1 negative output
33	RCHG	Charging current setting
34	AMUTE	Reset inversion output
35	EMP	"Empty" detection output
36	HV _{CC}	H-bridge power supply input
37	PSW	PWM transistor drive
38	CLK	External clock synchronization input
39	START	Boost DC/DC converter starting
40	OFF	Boost DC/DC converter OFF
41	CHGV _{cc}	Charging circuit power supply input
42	SEL	"Empty" detection level switching
43	PREGND	Pre-unit power supply ground
44	PWMFIL	PWM phase compensation



4-CHANNEL MOTOR DRIVER WITH POWER CONTROLLER

AM5901A

Functional Block Diagram

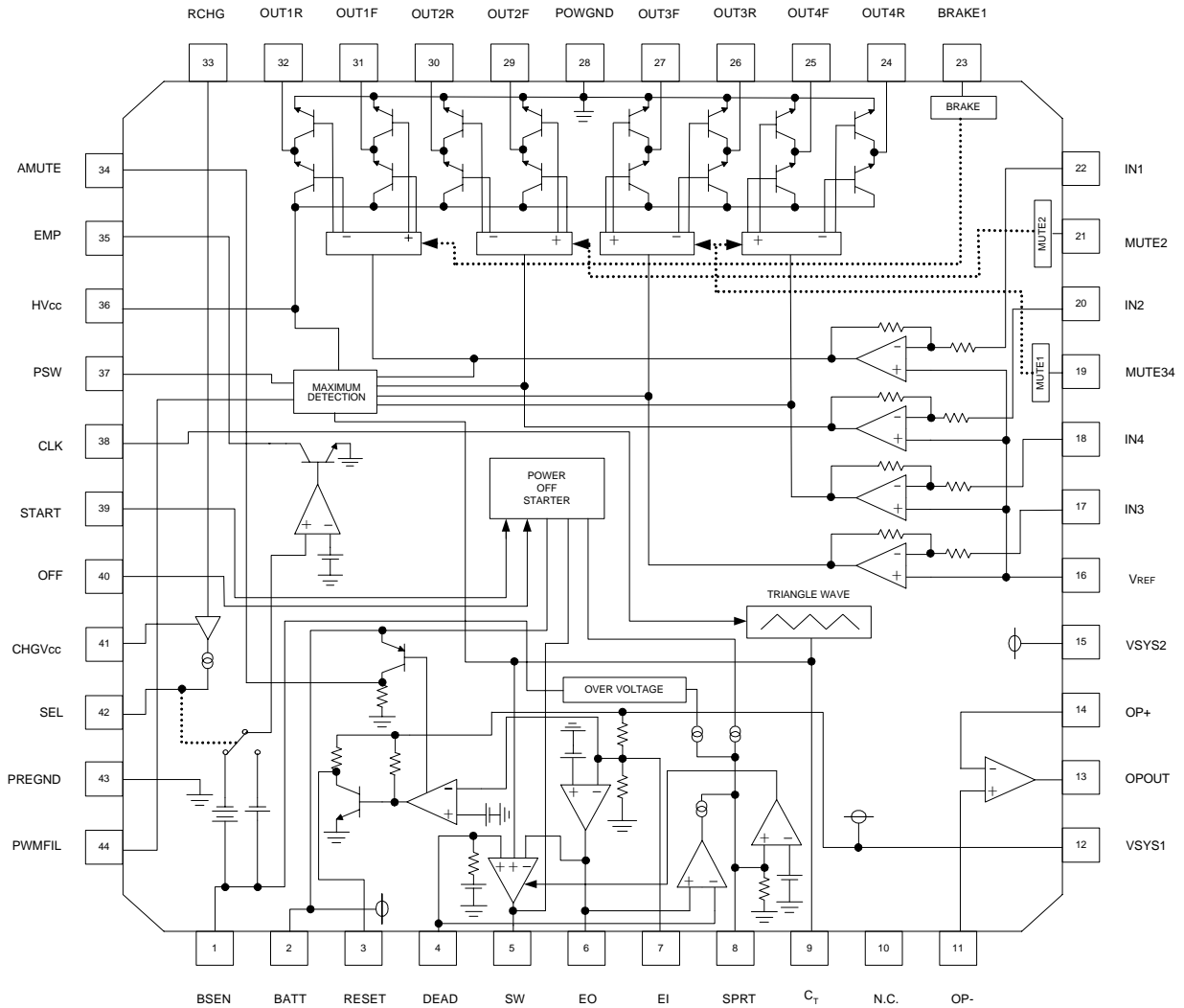

Figure 4. Functional Block Diagram of AM5901A



4-CHANNEL MOTOR DRIVER WITH POWER CONTROLLER

AM5901A

Ordering Information

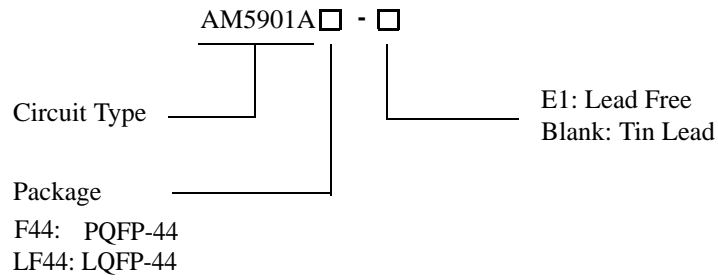

Package	Temperature Range	Part Number		Marking ID		Packing Type
		Tin Lead	Lead Free	Tin Lead	Lead Free	
PQFP-44	0 to 70°C	AM5901AF44	AM5901AF44-E1	AM5901AF44	AM5901AF44-E1	Tray
LQFP-44	0 to 70°C	AM5901ALF44	AM5901ALF44-E1	AM5901ALF44	AM5901ALF44-E1	Tray

BCD Semiconductor's Pb-free products, as designated with "E1" suffix in the part number, are RoHS compliant.

**4-CHANNEL MOTOR DRIVER WITH POWER CONTROLLER****AM5901A****Absolute Maximum Ratings (Note 1)**

Parameter	Symbol	Value	Unit
Supply Voltage	V_{CC}	13.5	V
Driver Output Current	I_O	500	mA
Power Dissipation	P_D	625 (Note 2)	mW
Operating Junction Temperature	T_J	150	°C
Storage Temperature	T_{STG}	-55 to 150	°C

Note 1: Stresses greater than those listed under "Absolute Maximum Ratings" may cause permanent damage to the device. These are stress ratings only, and functional operation of the device at these or any other conditions beyond those indicated under "Recommended Operating Conditions" is not implied. Exposure to "Absolute Maximum Ratings" for extended periods may affect device reliability.

Note 2: Power dissipation is reduced by 5mW for each increase in T_A of 1°C over 25°C.

Recommended Operating Conditions

Parameter	Symbol	Min	Typ	Max	Unit
Control Circuit Power Supply Voltage	VSYS1	2.7	3.2	5.5	V
Pre-driver Power Supply Voltage	VSYS2	2.7	3.2	5.5	V
H-bridge Power Supply Voltage	HV_{CC}		PWM	BATT	V
Power Unit Power Supply Voltage	BATT (V_{CC})	1.6	2.4	8	V
Charging Circuit Power Supply Voltage	CHGV $_{CC}$	3.0	4.5	8	V
Operating Temperature	T_A	0	25	70	°C



4-CHANNEL MOTOR DRIVER WITH POWER CONTROLLER

AM5901A

Electrical Characteristics

(Typicals and limits apply for $T_A=25^\circ\text{C}$, $\text{BATT}=2.4\text{V}$, $\text{VSYS1}=\text{VSYS2}=3.2\text{V}$, $V_{\text{REF}}=1.6\text{V}$, $\text{CHGV}_{\text{CC}}=0$, $\text{CLK}=88.2\text{kHz}$, unless otherwise specified.)

Parameter	Symbol	Conditions	Min	Typ	Max	Unit
Common Section						
BATT Standby Current	I_{ST}	$\text{BATT}=9\text{V}$, $\text{VSYS1}=\text{VSYS2}=\text{V}_{\text{REF}}=0\text{V}$		0	5	μA
BATT Supply Current at No Load	I_{BAT}	$\text{HV}_{\text{CC}}=0.45\text{V}$, $\text{MUTE34}=3.2\text{V}$		2.5	4	mA
VSYS1 Supply Current at No Load	I_{SYS1}	$\text{HV}_{\text{CC}}=0.45\text{V}$, $\text{MUTE34}=3.2\text{V}$, $\text{EI}=0\text{V}$		4.7	6.4	mA
VSYS2 Supply Current at No Load	I_{SYS2}	$\text{HV}_{\text{CC}}=0.45\text{V}$, $\text{MUTE34}=3.2\text{V}$		4.1	5.5	mA
CHGV _{CC} Supply Current at No Load	I_{CHGVCC}	$\text{CHGV}_{\text{CC}}=4.5\text{V}$, $\text{R}_{\text{OUT}}=\text{OPEN}$		0.65	2	mA
H-bridge Driver Section						
Voltage Gain (CH1,3,4)	G_{VC134}		12	14	16	dB
Voltage Gain (CH2)	G_{VC2}		21.5	23.5	25.5	dB
Gain Error by Polarity	ΔG_{VC}		-2	0	2	dB
IN Pin Input Resistance (CH1,3,4)	R_{IN134}	$\text{IN}=1.7$ and 1.8V	9.6	11	14.4	k Ω
IN Pin Input Resistance (CH2)	R_{IN2}	$\text{IN}=1.7$ and 1.8V	6.6	7.5	9.9	k Ω
Maximum Output Voltage	V_{OUT}	$\text{R}_L=8\Omega$, $\text{HV}_{\text{CC}}=\text{BATT}=4\text{V}$, $\text{IN}=0$ to 3.2V	1.9	2.1		V
Lower Transistor Saturated Voltage	V_{SATL}	$\text{I}_O=-300\text{mA}$, $\text{IN}=0$ and 3.2V		240	400	mV
Upper Transistor Saturated Voltage	V_{SATU}	$\text{I}_O=300\text{mA}$, $\text{IN}=0$ and 3.2V		240	400	mV
Input Offset Voltage	V_{IO}		-8		8	mV
Output Offset Voltage (CH1,3,4)	V_{OO134}	$\text{V}_{\text{REF}}=\text{IN}=1.6\text{V}$	-54	0	54	mV
Output Offset Voltage (CH2)	V_{OO2}	$\text{V}_{\text{REF}}=\text{IN}=1.6\text{V}$	-134	0	134	mV
Dead Zone	V_{DB}		-15	0	15	mV
BRAKE1 ON Threshold Voltage	V_{BRON}	$\text{IN1}=1.8\text{V}$	2			V
BRAKE1 OFF Threshold Voltage	V_{BROFF}	$\text{IN1}=1.8\text{V}$			0.8	V
MUTE2 ON Threshold Voltage	V_{M2ON}	$\text{IN2}=1.8\text{V}$	2			V
MUTE2 OFF Threshold Voltage	V_{M2OFF}	$\text{IN2}=1.8\text{V}$			0.8	V



4-CHANNEL MOTOR DRIVER WITH POWER CONTROLLER

AM5901A

Electrical Characteristics (Continued)

Parameter	Symbol	Conditions	Min	Typ	Max	Unit
MUTE34 ON Threshold Voltage	V_{M34ON}	IN3=IN4=1.8V			0.8	V
MUTE34 OFF Threshold Voltage	V_{M34OFF}	IN3=IN4=1.8V	2.0			V
V_{REF} ON Threshold Voltage	V_{REFON}	IN1=IN2=IN3=IN4=1.8V	1.2			V
V_{REF} OFF Threshold Voltage	V_{REFOFF}	IN1=IN2=IN3=IN4=1.8V			0.8	V
BRAKE 1 Brake Current	I_{BRAKE1}	Current difference between BRAKE1 pin "H" and "L"	4	7	10	mA
PWM Power Supply Driving Section						
PWM Sink Current	I_{PSW}	IN1=2.1V	7.9	13	17.5	mA
HV _{CC} Level Shift Voltage	V_{SHIF}	IN1=1.8V, HV _{CC} -OUT1F	0.25	0.45	0.55	V
HV _{CC} Leak Current	I_{HLK}	HV _{CC} =9V, VSYS1=VSYS2=BATT=0V		0	11	μA
PWM Amplifier Transfer Gain	G_{PWM}	IN1=1.8V, HV _{CC} =1.2 to 1.4V	1/60	1/50	1/40	1/kΩ
DC/DC Converter Section						
(Error Amplifier Section)						
VSYS1 Pin Threshold Voltage	V_{SITH}		3.05	3.2	3.35	V
EO Pin Output Voltage H	V_{EOH}	EI=0.7V, I _O =-80μA	1.4	1.6		V
EO Pin Output Voltage L	V_{EOL}	EI=1.3V, I _O =80μA			0.3	V
(Short-circuit Protection)						
SPRT Pin Voltage (Normal)	V_{SPR}	EI=1.3V		0	0.1	V
SPRT Pin Current 1 EO=H	I_{SPR1}	EI=0.7V	6	10	16	μA
SPRT Pin Current 2 EO=L	I_{SPR2}	EI=1.3V, OFF=0V	12	20	32	μA
SPRT Pin Current 3 (Over-voltage)	I_{SPR3}	EI=1.3V, BATT=9.5V	12	20	32	μA
SPRT Pin Impedance	R_{SPR}		175	220	265	kΩ
SPRT Pin Threshold Voltage	V_{SPTH}	EI=0.7, C _T =0V	1.1	1.2	1.3	V
Over-voltage Protection Detect	V_{HVPR}	BSEN Pin Voltage, pin 7=1.3V, pin 12=3.2V	8	8.6	9	V
(Transistor Driving Section)						
SW Pin Output Voltage 1 H	V_{SW1H}	BATT=C _T =1.5V, I _O =-2mA, VSYS1=VSYS2=0V, at start	0.78	0.98	1.13	V
SW Pin Output Voltage 2 H	V_{SW2H}	C _T =0V, I _O =-10mA, EI=0.7V, SPRT=0V	1	1.5		V
SW Pin Output Voltage 2 L	V_{SW2L}	C _T =2V, I _O =10mA		0.3	0.45	V
SW Pin Oscillating Frequency 1	f_{SW1}	C _T =470pF, VSYS1=VSYS2=0, at start	65	80	95	kHz
SW Pin Oscillating Frequency 2	f_{SW2}	C _T =470pF, CLK=0V	60	70	82	kHz



4-CHANNEL MOTOR DRIVER WITH POWER CONTROLLER

AM5901A

Electrical Characteristics (Continued)

Parameter	Symbol	Conditions	Min	Typ	Max	Unit
SW Pin Oscillating Frequency 3	f_{SW3}	$C_T=470pF$		88.2		kHz
SW Pin Minimum Pulse Width	T_{SWMIN}	$C_T=470pF, EO=0.5\sim 0.7V$ Sweep	0.01		0.6	μs
Pulse Duty at Start	D_{SW1}	$C_T=470pF, V_{SYS1}=V_{SYS2}=0V$	40	50	60	%
Max Pulse Duty at Self-Running	D_{SW2}	$EI=0.7V, C_T=470pF, CLK=0V,$ $SPRT=1.1V, START$ not connected	70	80	90	%
Max Pulse Duty at CLK Synchroni- zation	D_{SW3}	$EI=0.7V, C_T=470pF, SPRT=1.1V,$ $START$ not connected	65	75	85	%
(Dead Time Section)						
DEAD Pin Impedance	R_{DEAD}		20	25	30	$k\Omega$
DEAD Pin Output Voltage	V_{DEAD}		0.78	0.88	0.98	V
(Interface Section)						
OFF Pin Threshold Voltage	V_{OFTH}	$EI=1.3V$			V_{SYS1-2}	V
OFF Pin Bias Current	I_{OFF}	$OFF=0V$	75	95	115	μA
START Pin ON Threshold Voltage	V_{STATH1}	$V_{SYS1}=V_{SYS2}=0V, C_T=2V$			BATT -1	V
START Pin OFF Threshold Voltage	V_{STATH2}	$V_{SYS1}=V_{SYS2}=0V, C_T=2V$	BATT -0.3			V
START Pin Bias Current	I_{START}	$START=0V$	10	16	19	μA
CLK Pin Threshold Voltage H	V_{CLKTHH}		2			V
CLK Pin Threshold Voltage L	V_{CLKTHL}				0.8	V
CLK Pin Bias Current	I_{CLK}	$CLK=3.2V$			10	μA
(Started Circuit Section)						
Starter Switching Voltage	V_{STMM}	$V_{SYS1}=V_{SYS2}=0V$ to 3.2V $START=0V$	2.3	2.5	2.7	V
Starter Switching Hysteresis Width	V_{SNHS}	$START=0V$	18	200	300	mV
Discharge Release Voltage	V_{DIS}		1.63	1.83	2.03	V
(Empty Detection Section)						
Empty Detection Voltage 1	V_{EMPT1}	$V_{SEL}=0V$	2.1	2.2	2.35	V
Empty Detection Voltage 2	V_{EMPT2}	$I_{SEL}=-2\mu A$	1.7	1.8	1.945	V
Empty Detection Hysteresis Width1	V_{EMHS1}	$V_{SEL}=0V$	8	50	100	mV
Empty Detection Hysteresis Width2	V_{EMHS2}	$I_{SEL}=-2\mu A$	8	50	100	mV
EMP Pin Output Voltage	V_{EMP}	$I_O=1mA, BSEN=1V$			0.5	V
EMP Pin Output Leak Current	I_{EMPL}	$BSEN=2.4V$			1	μA
BSEN Pin Input Resistance	R_{BSEN}	$V_{SEL}=0V$	17	23	27	$k\Omega$



4-CHANNEL MOTOR DRIVER WITH POWER CONTROLLER

AM5901A

Electrical Characteristics (Continued)

Parameter	Symbol	Conditions	Min	Typ	Max	Unit
BSEN Pin Leak Current	I_{BSNL}	VSYS1=VSYS2=0V, BSEN=4.5V			1	μA
SEL Pin Detection Voltage	V_{SELTH}	$V_{SELTH}=BATT-SEL$, BSEN=2V	1.35			V
SEL Pin Detection Current	I_{SELT}		-15			μA
(Reset Section)						
VSYS1 Reset Threshold Voltage Ratio	H_{SRT}	Ratio of VSYS1 voltage and error-amp threshold voltage	82.98	90	97.2	%
RESET Detection Hysteresis Width	V_{RSTHS}		10	50	100	mV
RESET Pin Output Voltage	V_{RST}	$I_O=1mA$, VSYS1=VSYS2=2.8V			0.5	V
RESET Pin Pull-up Resistance	R_{RST}		72	90	108	k Ω
AMUTE Pin Output Voltage 1	V_{AMT1}	$I_O=-1mA$, VSYS1=VSYS2=2.8V	BATT -0.4		BATT	V
AMUTE Pin Output Voltage 2	V_{AMT2}	$I_O=-1mA$, START=0V, VSYS1=VSYS2=0V	BATT -0.4		BATT	V
AMUTE Pin Pull Down Resistance	R_{AMT}		77	95	113	k Ω
(Operational Amplifier Section)						
Input Bias Current	I_{BIAS}	OP+=1.6V			300	nA
Input Offset Voltage	V_{IOOP}		-5.5	0	5.5	mV
High Level Output Voltage	V_{OHOP}	$R_L=OPEN$	2.8			V
Low Level Output Voltage	V_{OLOP}	$R_L=OPEN$			0.2	V
Output Driver Current (Source)	I_{SOU}	Output shorted to GND By 50 Ω		-6.5	-3	mA
Output Driver Current (Sink)	I_{SIN}	Output shorted to VSYS By 50 Ω	0.3	0.7	2.2	mA
Open Loop Voltage GAIN	G_{VO}	$V_{IN}=-75dBV$, f=1kHz		70		dB
Slew Rate	SR			0.5		V/ μs
(Charging Circuit Section)						
SEL Pin Charging Current	I_{SEL}	CHGV _{CC} =4.5V, RCHG=1.8k Ω , V _{SEL} =4.5V	80	150	250	mA
RCHG Pin Bias Voltage	V_{RCHG}	CHGV _{CC} =4.5V, RCHG=1.8k Ω	0.745	0.81	0.960	V
RCHG Pin Output Resistance	R_{RCHG}	CHGV _{CC} =4.5V, RCHG=0.5 and 0.6V	0.75	0.95	1.2	k Ω
SEL Pin Leak Current 1	I_{SELLK1}	CHGV _{CC} =4.5V, RCHG=OPEN BATT=4.5V			1.2	μA
SEL Pin Leak Current 2	I_{SELLK2}	CHGV _{CC} =0.6V, RCHG=1.8k Ω BATT=4.5V			1.2	μA
SEL Pin Saturation Voltage	V_{SELCG}	CHGV _{CC} =4.5V, I _O =300mA, RCHG=0 Ω		0.45	1	V



4-CHANNEL MOTOR DRIVER WITH POWER CONTROLLER

AM5901A

Typical Performance Characteristics

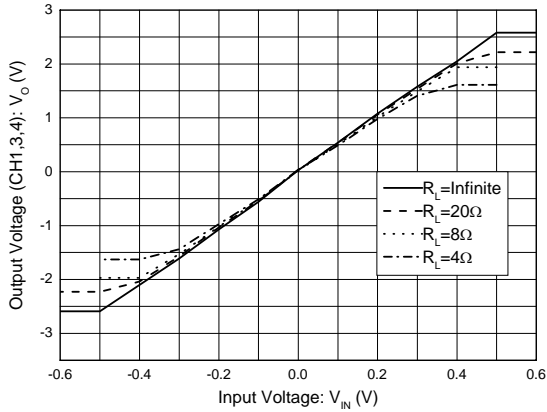

Figure 5. Input Load Fluctuation (CH1, 3, 4, Note 3)

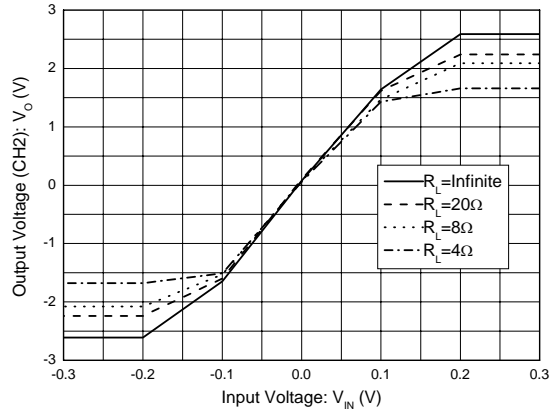

Figure 6. Input Load Fluctuation (CH2, Note 3)

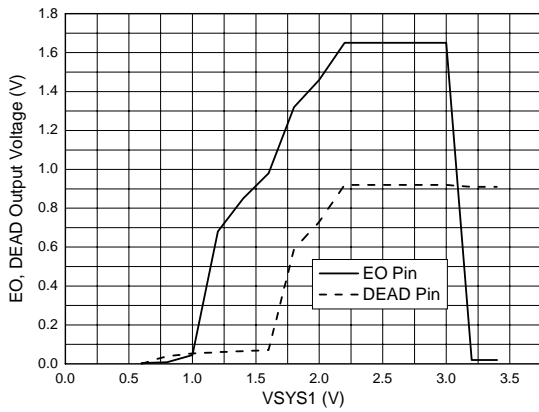

Figure 7. Error Amplifier Output Voltage

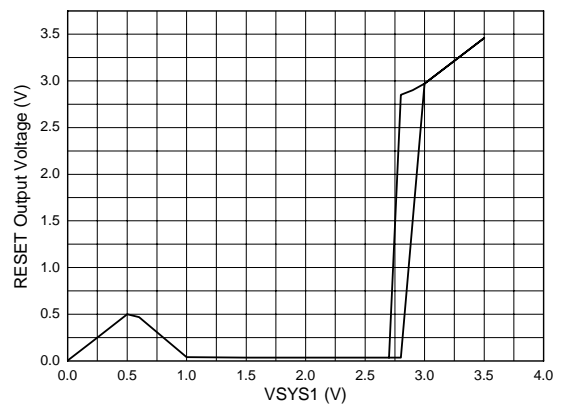

Figure 8. RESET Pin Voltage

Note 3: Input voltage herein is referenced to Bias pin voltage.



4-CHANNEL MOTOR DRIVER WITH POWER CONTROLLER

AM5901A

Typical Application

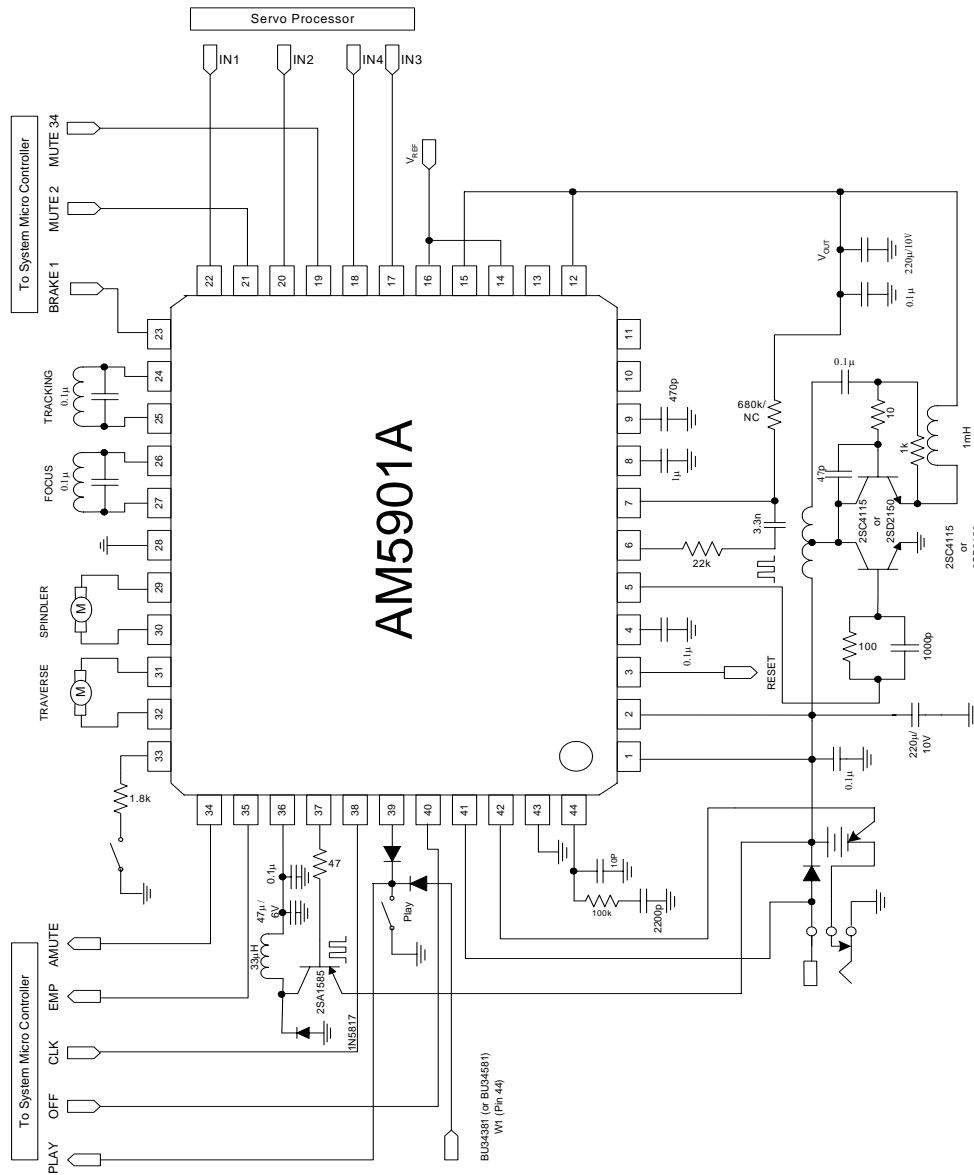

Figure 9. Typical Application 1 of AM5901A in Portable CD/VCD Player



4-CHANNEL MOTOR DRIVER WITH POWER CONTROLLER

AM5901A

Application Information

H-Bridge Driver

1. Mute Function

Brake function is assigned to CH1, mute function is assigned to other 3 channels.

(1) CH1 is in normal operation when the BRAKE pin is low (high when CH1 mute on), and enters a brake mode.

(2) CH2 is in normal operation when the MUTE2 pin is low (high when CH2 mute on).

(3) CH3,4 are in normal operation when the MUTE34 pin is high (low when CH3,4 mute on).

2. V_{REF} Drop Mute

When the voltage impressed to V_{REF} terminal is 1.0V (Typ.) or less, impedance of driver output becomes "high".

3. Thermal Shutdown

If the chip temperature rises above 140 °C, then the thermal shutdown (TSD) circuit is activated and the output current is cut. When the chip temperature has dropped to 100°C, then output current begins to flow.

4. Driver Gain

Driver input resistance is 11kΩ (CH1, CH3, CH4) and 7.5kΩ (CH2). Driver gain can be calculated by the expression.

$$CH1,3,4 \quad G_V = 20 \log |55k/(R+11k)|$$

$$CH2 \quad G_V = 20 \log |110k/(R+7.5k)|$$

R is an external resistance

The power supply of driver output stage is HV_{CC} terminal and that of pre-driver circuit is V_{SYS2} terminal. Attach a by-pass capacitor (approximately 0.1μF) between the power supplies as near as possible to this chip.

DC/DC Converter Control Circuit

1. Output Voltage

Booster circuit of voltage (V_{SYS1}) can be configured with external component. The voltage is defined as follows.

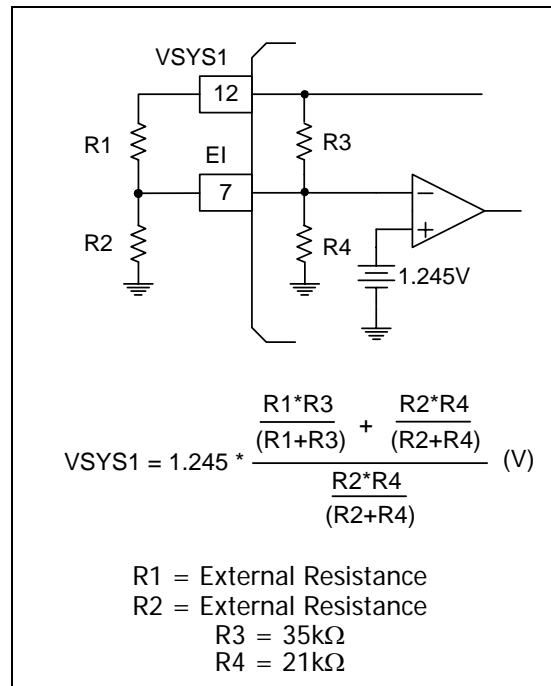

2. Short-Circuit Protection Function

When the output of error amplifier is "H", if the voltage of SPRT terminal has reached 1.245V (Typ.) upon charging the terminal, switching of SW terminal is disabled. Time to disable switching depends on the capacitor of SPRT terminal and it can be calculated by the expression:

$$t = C_{SPRT} * V_{TH} / I_{SPRT} \text{ (sec)}$$

(V_{TH}=1.245V, I_{SPRT}=10μA)



4-CHANNEL MOTOR DRIVER WITH POWER CONTROLLER

AM5901A

Application Information (Continued)

3. Soft-Start Function

The soft-start is functioned by putting a capacitor between DEAD terminal and GND, the maximum duty can be changed by attaching a resistance to pin 4.

$$t = C_{DEAD} * R \text{ (sec)}$$

$$(R=65k\Omega)$$

4. Power-Off Operation

SPRT terminal is charged by setting OFF terminal to "L". Then, switching of SW terminal is terminated when the voltage of the SPRT terminal has reached 1.245V (Typ.). Time to disable switching depends on a capacitor of the SPRT terminal and it can be calculated by the expression:

$$t = C_{SPRT} * V_{TH} / I_{OFF} \text{ (sec)}$$

$$(V_{TH} = 1.245V, I_{HV} = 20\mu A)$$

5. Over-Voltage Protection Operation

When the voltage applied to BSEN terminal has been 8.4V (Typ.), SPRT terminal is charged. Then, switching of SW terminal is terminated when the voltage of the SPRT terminal has reached 1.245V (Typ.). Time to disable switching depends on a capacitor of SPRT terminal and it can be calculated by the expression:

$$t = C_{SPRT} * V_{TH} / I_{HV} \text{ (sec)}$$

$$(V_{TH} = 1.245V, I_{HV} = 20\mu A)$$

PWM Power Supply Driver Circuit

This circuit detects a maximum output level of drivers of four channels and performs the PWM supply of load drive power supply. This circuit uses PNP transistor, Schottky Diode and capacitor as external component.

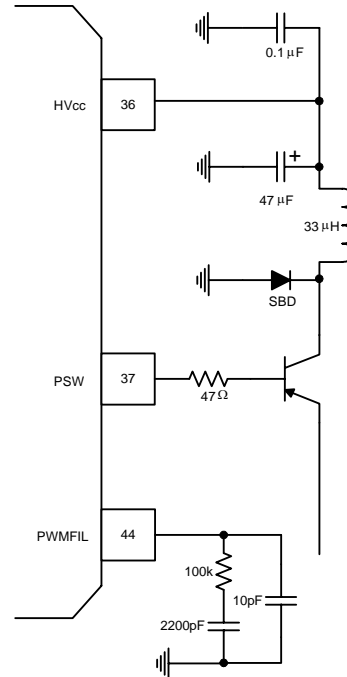

"Empty" Detector Unit

When the voltage applied to BSEN terminal has reached the detecting voltage or less. EMP terminal varies from "H" to "L" (open collector output). Hysteresis of 50mV (Typ.) is set to the detecting voltage to prevent the output chattering. The detecting voltage varies depending on SEL terminal as follows:

SEL Pin	Detecting Voltage	Return Voltage
L	2.2V (Typ.)	2.25V (Typ.)
High-Z	1.8V (Typ.)	1.85V (Typ.)

**4-CHANNEL MOTOR DRIVER WITH POWER CONTROLLER****AM5901A****Application Information (Continued)****Reset Circuit**

Upon 90% of DC/DC converter output voltage, RESET terminal varies from "L" to "H" and AMUTE terminal changes from "H" to "L". Hysteresis of 50mV (Typ.) is set to the reset voltage to prevent the output chattering.

Charging Circuit

The power supply of the charging unit is from $CHGV_{CC}$ terminal and it is independent of any

other circuits. Charging current is set by the resistance between RCHG terminal and GND. The charging current takes constant current through SEL terminal.

This circuit has a private thermal shutdown circuit. When the chip temperature has risen to 140°C, the charging current is cut off. When the chip temperature has dropped to 100°C, the charging current begins to flow.



4-CHANNEL MOTOR DRIVER WITH POWER CONTROLLER

AM5901A

Mechanical Dimensions

LQFP-44

Unit: mm(inch)

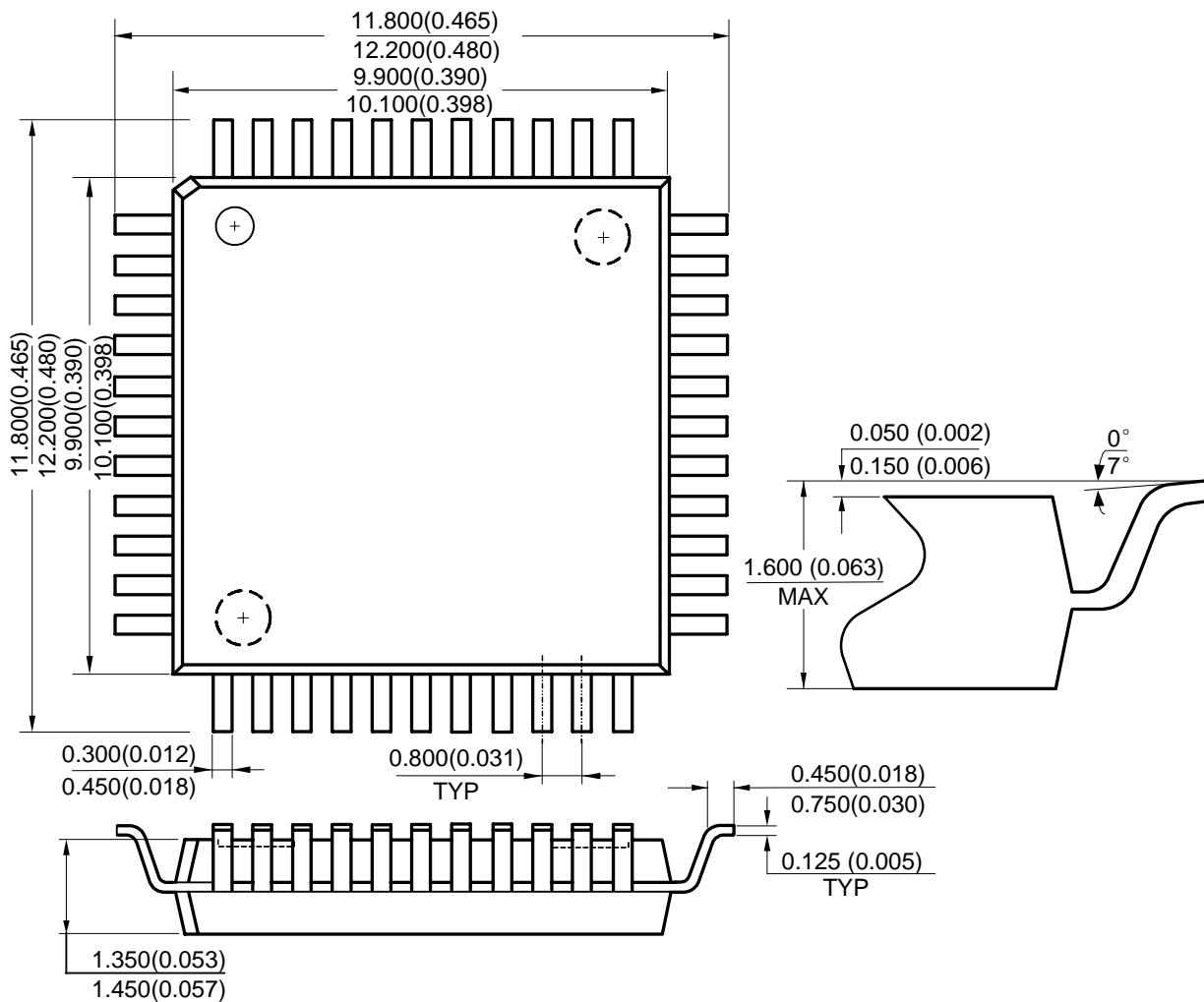



4-CHANNEL MOTOR DRIVER WITH POWER CONTROLLER

AM5901A

Mechanical Dimensions (Continued)

PQFP-44

Unit: mm(inch)

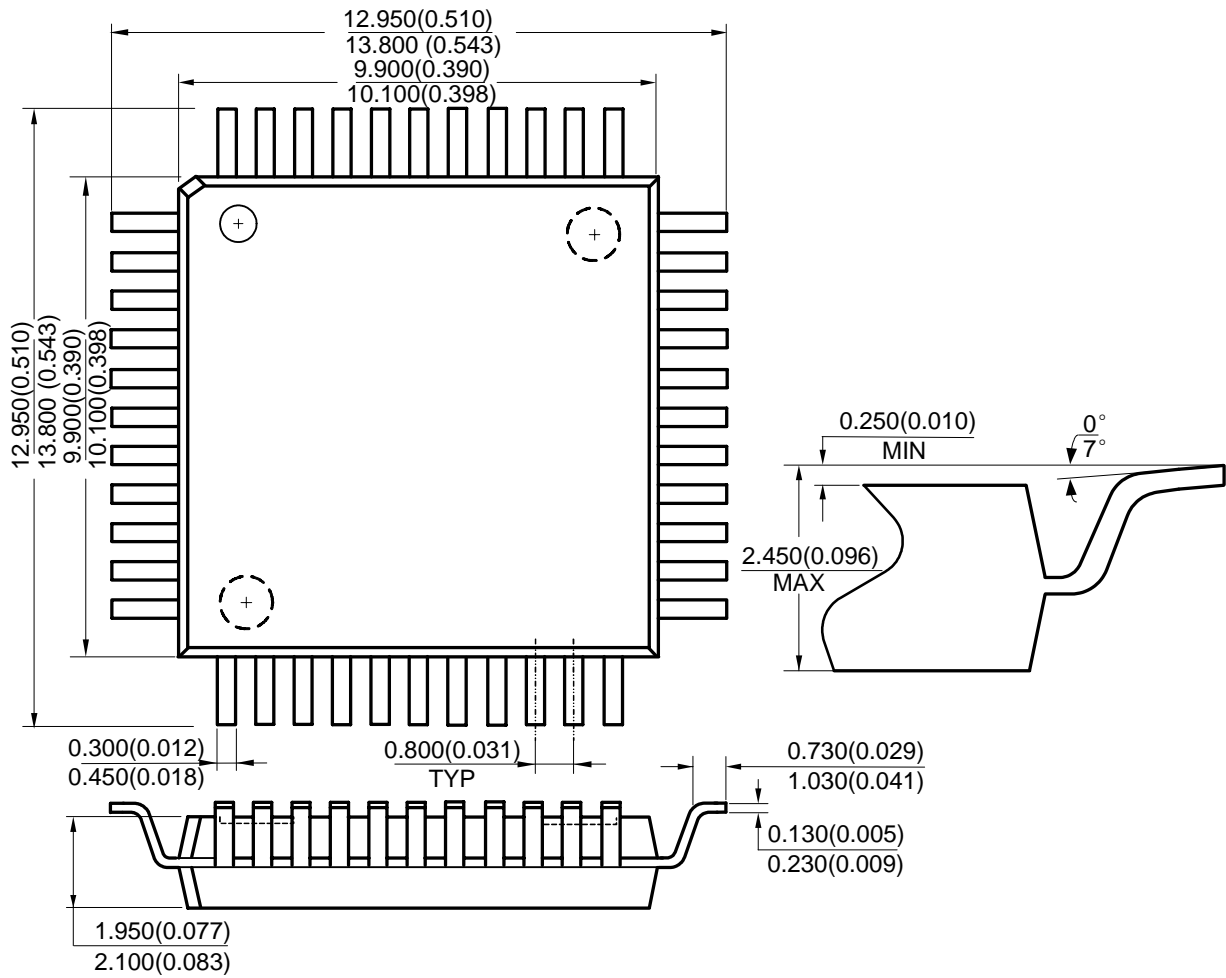



BCD Semiconductor Manufacturing Limited

<http://www.bcdsemi.com>

IMPORTANT NOTICE

BCD Semiconductor Manufacturing Limited reserves the right to make changes without further notice to any products or specifications herein. BCD Semiconductor Manufacturing Limited does not assume any responsibility for use of any its products for any particular purpose, nor does BCD Semiconductor Manufacturing Limited assume any liability arising out of the application or use of any its products or circuits. BCD Semiconductor Manufacturing Limited does not convey any license under its patent rights or other rights nor the rights of others.

MAIN SITE

BCD Semiconductor Manufacturing Limited
- Wafer Fab
Shanghai SIM-BCD Semiconductor Manufacturing Limited
800, Yi Shan Road, Shanghai 200233, China
Tel: +86-21-6485 1491, Fax: +86-21-5450 0008

BCD Semiconductor Manufacturing Limited
- IC Design Group
Advanced Analog Circuits (Shanghai) Corporation
8F, Zone B, 900, Yi Shan Road, Shanghai 200233, China
Tel: +86-21-6495 9539, Fax: +86-21-6485 9673

REGIONAL SALES OFFICE

Shenzhen Office
Shanghai SIM-BCD Semiconductor Manufacturing Co., Ltd. Shenzhen Office
Advanced Analog Circuits (Shanghai) Corporation Shenzhen Office
Room E, 5F, Noble Center, No.1006, 3rd Fuzhong Road, Futian District, Shenzhen 518026, China
Tel: +86-755-8826 7951
Fax: +86-755-8826 7865

Taiwan Office
BCD Semiconductor (Taiwan) Company Limited
4F, 298-1, Rui Guang Road, Nei-Hu District, Taipei,
Taiwan
Tel: +886-2-2656 2808
Fax: +886-2-2656 2806

USA Office
BCD Semiconductor Corporation
30920 Huntwood Ave. Hayward,
CA 94544, U.S.A
Tel : +1-510-324-2988
Fax: +1-510-324-2788