



AMC34063A

DC - DC CONVERTER CONTROL CIRCUITS

DESCRIPTION	FEATURES
<p>The AMC34063A is designed for the applications which require DC - DC converters. It can be operated in a wide input range from 3.0V to 40V and has the controlled duty cycle oscillator, driver and high current output switch. Also, With the internal temperature compensation circuit, the AMC34063A provides an internally trimmed precision 2% reference voltage of 1.25V. These features make the AMC34063A suitable for step-up, step-down and voltage-inverting applications.</p>	<ul style="list-style-type: none"> ■ Wide Input Operating Range: 3.0V to 40V ■ Output Switch Current up to 1.5A ■ 100KHz operational Frequency ■ Low Standby Current □ Internally trimmed 2% 1.25V Reference Voltage □ Adjustable Output Voltage □ Available in 8 Pin Plastic DIP and 8 Pin S.O Packages □ Direct pin-to-pin replacement for industrial product MC34063A.

APPLICATIONS

- Chargers
- Adaptors
- Mother Board
- Scanner

PACKAGE PIN OUT

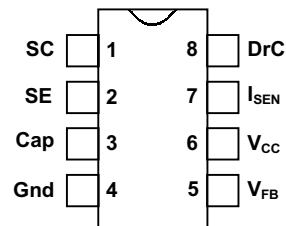

**M PACKAGE
(TOP VIEW)**

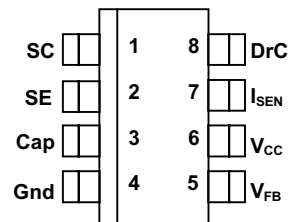

**DM PACKAGE
(TOP VIEW)**

ORDER INFORMATION			
T_A (°C)	M	Plastic DIP 8-pin	DM
0 to 70	AMC34063AM		AMC34063ADM
Note: All surface-mount packages are available in Tape & Reel. Append the letter "T" to part number (i.e. AMC34063ADMT).			

ABSOLUTE MAXIMUM RATINGS	
Power Supply Voltage (V_{CC})	40V
Operating Junction temperature	
Plastic (M, DM Package)	150°C
Storage Temperature Range	-65°C to 150°C
Lead temperature (Soldering, 10 seconds)	300°C
Note 1: Exceeding these ratings could cause damage to the device. All voltages are with respect to Ground. Currents are positive into, negative out of the specified terminal.	

THERMAL DATA	
M PACKAGE:	
Thermal Resistance-Junction to Ambient, θ_{JA}	95°C/W
DM PACKAGE:	
Thermal Resistance-Junction to Ambient, θ_{JA}	165°C/W

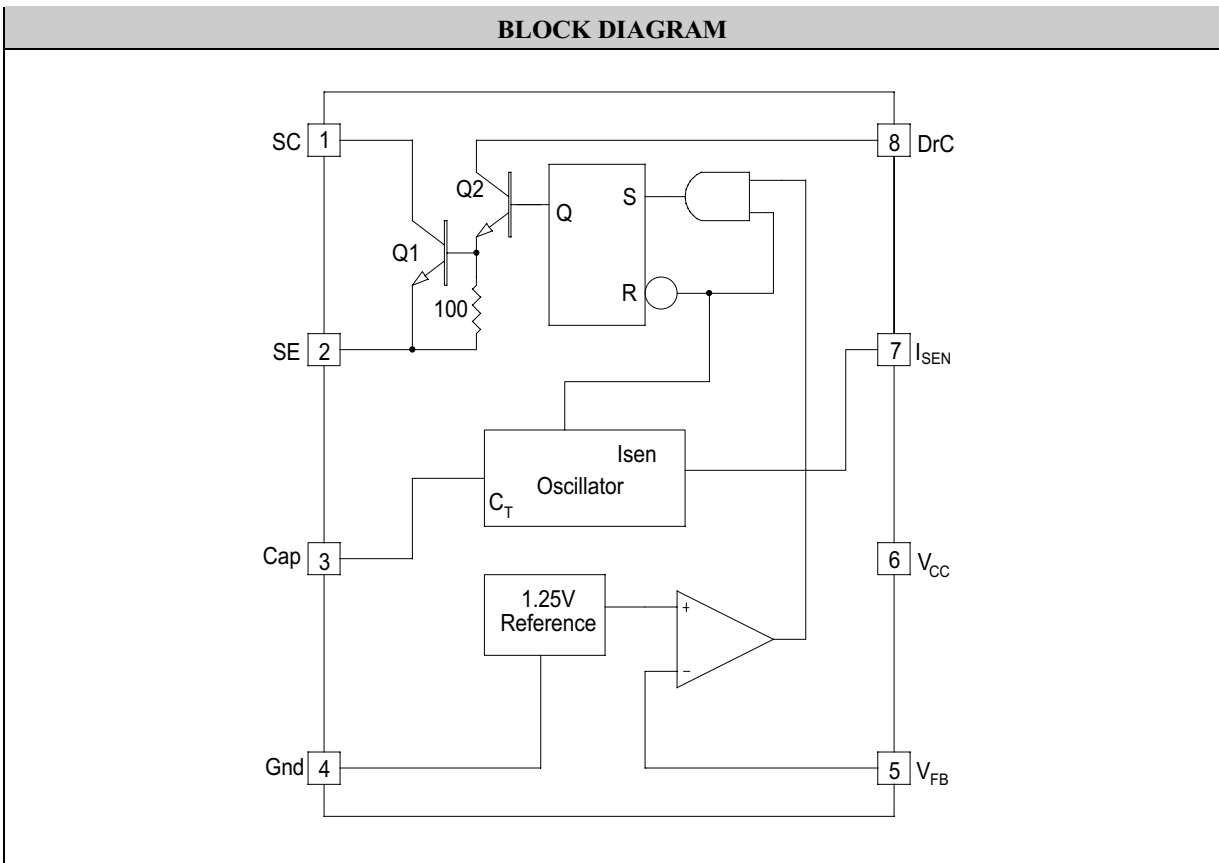

Pin Assignment Descriptions	
Pin 1 : SC - Switch Collector	Pin 8 : DrC - Driver Collector
Pin 2 : SE - Switch Emitter	Pin 7 : I _{SEN} - I Peak Sense
Pin 3 : Cap - Oscillator Timing Capacitor	Pin 6 : V _{CC} - Power Supply
Pin 4 : Gnd - Ground	Pin 5 : V _{FB} - Comparator inverting input

RECOMMENDED OPERATING CONDITIONS					
Parameter	Symbol	Recommended Operating			Units
		Min.	Typ.	Max.	
Comparator Input Voltage	V_{FB}	-0.3 to +40			V
Switch Collector Voltage	$V_{C(\text{switch})}$			40	V
Switch Emitter Voltage ($V_{Pin1}=40V$)	$V_{E(\text{switch})}$			40	V
Switch Collector to Emitter Voltage	$V_{CE(\text{switch})}$			40	V
Driver Collector Voltage	$V_{C(\text{driver})}$			40	V
Driver Collector Current (Note 1)	$I_{C(\text{driver})}$			100	mA
Switch Current	I_{SW}			1.5	A
Timing Capacitor (connected to Cap pin)	C_T		1		nF
Operating Ambient Temperature Range	T_A	0 to +70			$^{\circ}C$

Note 1: Maximum package power dissipation limits must be observed.

ELECTRICAL CHARACTERISTICS						
$V_{CC}=5.0\text{ V}$, $T_A=0^{\circ}C$ to $70^{\circ}C$, unless otherwise specified.						
Parameter	Symbol	Test Conditions	AMC34063A			Units
			Min.	Typ.	Max.	
OSCILLATOR						
Frequency	f_{osc}	$V_{Pin5} = 0\text{ V}$, $C_T = 1.0\text{ nF}$, $T_A = 25^{\circ}C$	24	33	42	KHz
Charge Current	I_{chg}	$V_{CC} = 5.0\text{ V to }40\text{ V}$, $T_A = 25^{\circ}C$	24	35	42	μA
Discharge Current	I_{dischg}	$V_{CC} = 5.0\text{ V to }40\text{ V}$, $T_A = 25^{\circ}C$	140	220	260	μA
Discharge to Charge Current Ratio	I_{dischg}/I_{chg}	Pin 7 to V_{CC} , $T_A = 25^{\circ}C$	5.2	6.5	7.5	-
Current Limit Sense Voltage	V_{sense}	$I_{chg} = I_{dischg}$, $T_A = 25^{\circ}C$	250	300	350	mV
OUTPUT SWITCH						
Saturation Voltage, Darlington Connection	$V_{CE(\text{sat})}$	$I_{SW} = 1.0\text{ A}$, Pins 1, 8 connected	-	1.0	1.3	V
Saturation Voltage	$V_{CE(\text{sat})}$	$I_{SW} = 1.0\text{ A}$, $R_{pin8} = 82\ \Omega$ to V_{CC} , Forced $\beta = 20$	-	0.45	0.7	V
DC Current Gain	h_{FE}	$I_{SW} = 1.0\text{ A}$, $V_{CE} = 5.0\text{ V}$, $T_A = 25^{\circ}C$	50	75	-	-
Collector Off – State Current	$I_{C(\text{off})}$	$V_{CE} = 40\text{ V}$	-	0.01	100	μA
COMPARATOR						
Threshold Voltage	V_{th}	$T_A = 25^{\circ}C$	1.225	1.25	1.275	V
		$T_A = 0^{\circ}C$ to $70^{\circ}C$	1.21	-	1.29	
Threshold Voltage Line Regulation	Reg_{line}	$V_{CC} = 3.0\text{ V to }40\text{ V}$	-	1.4	5.0	mV
Input Bias Current	I_{IB}	$V_{FB} = 0\text{ V}$	-	-20	-400	nA
TOTAL DEVICE						
Supply current	I_{CC}	$V_{CC} = 5.0\text{ V to }40\text{ V}$, $C_T = 1.0\text{ nF}$, Pin 7 = V_{CC} , $V_{FB} > V_{th}$, Pin 2 = Gnd, remaining pins open	-	-	4.0	mA

CHARACTERIZATION CURVES

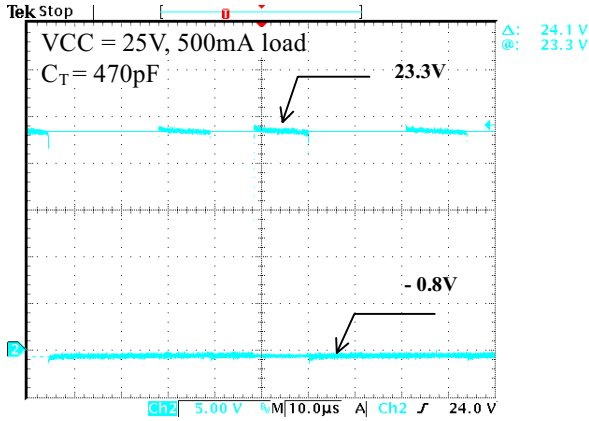

SE pin (PIN#2) waveform
on 5V step down converter

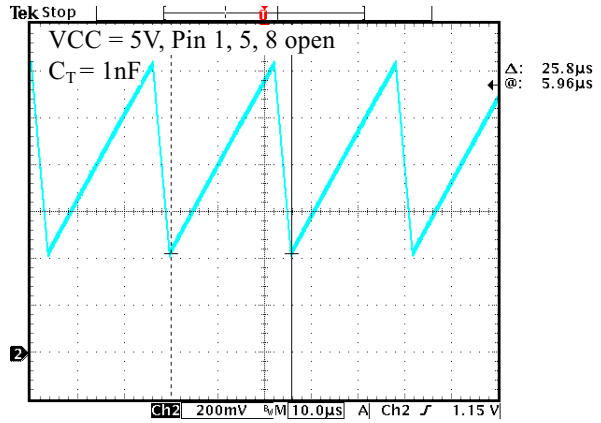

Cap pin (PIN#3) waveform

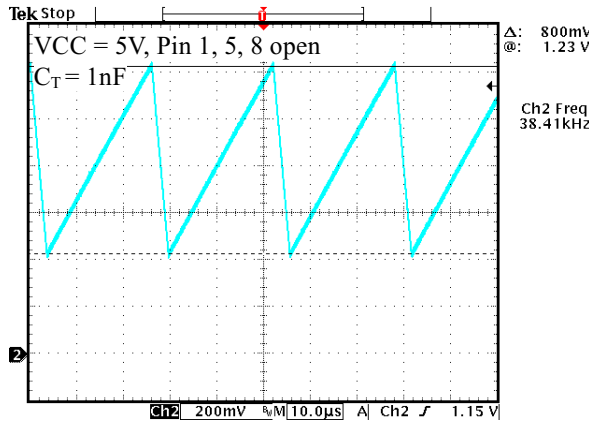

Cap pin (PIN#3) waveform

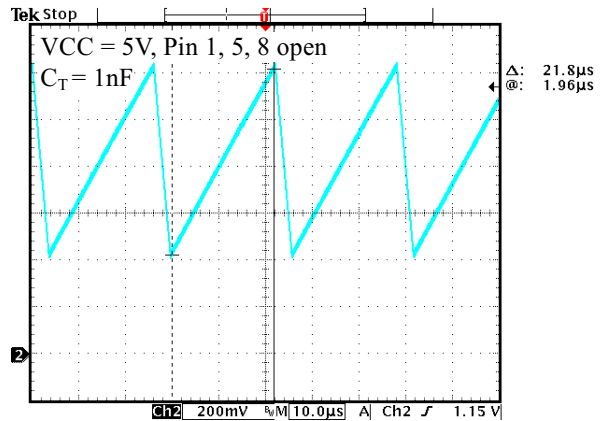

Cap pin (PIN#3) waveform

Figure 1 – Step-Up Converter Application Circuits

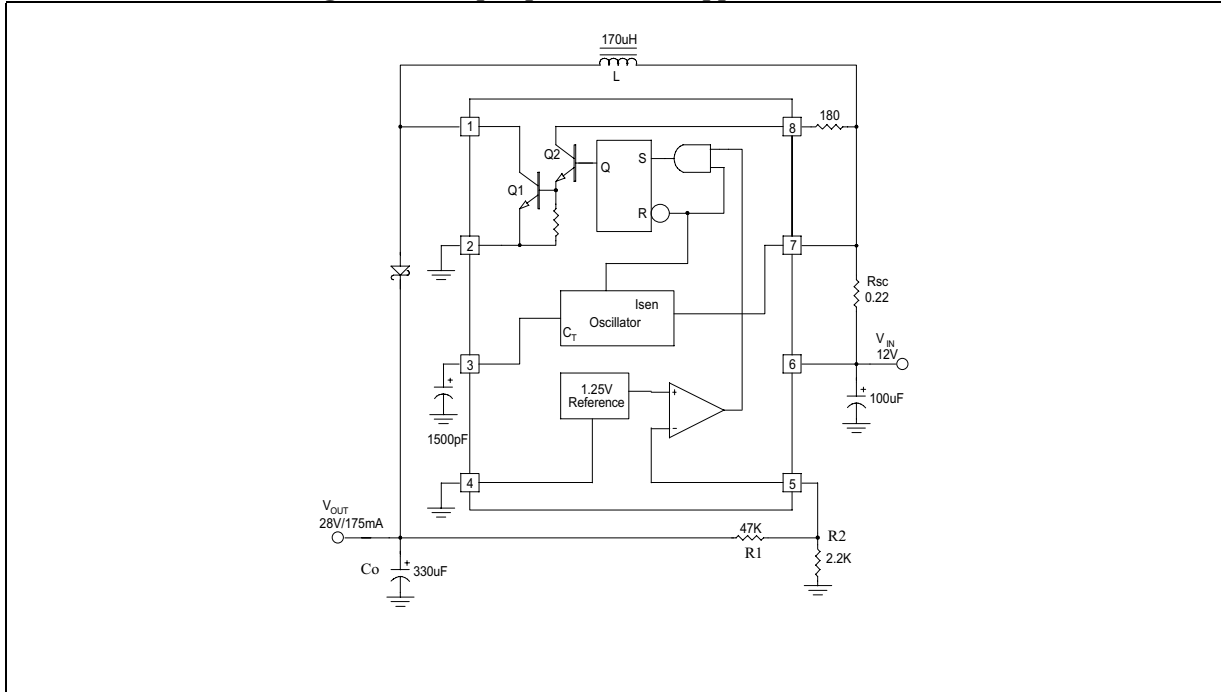

Figure 2 – Step-Down Converter Application Circuit

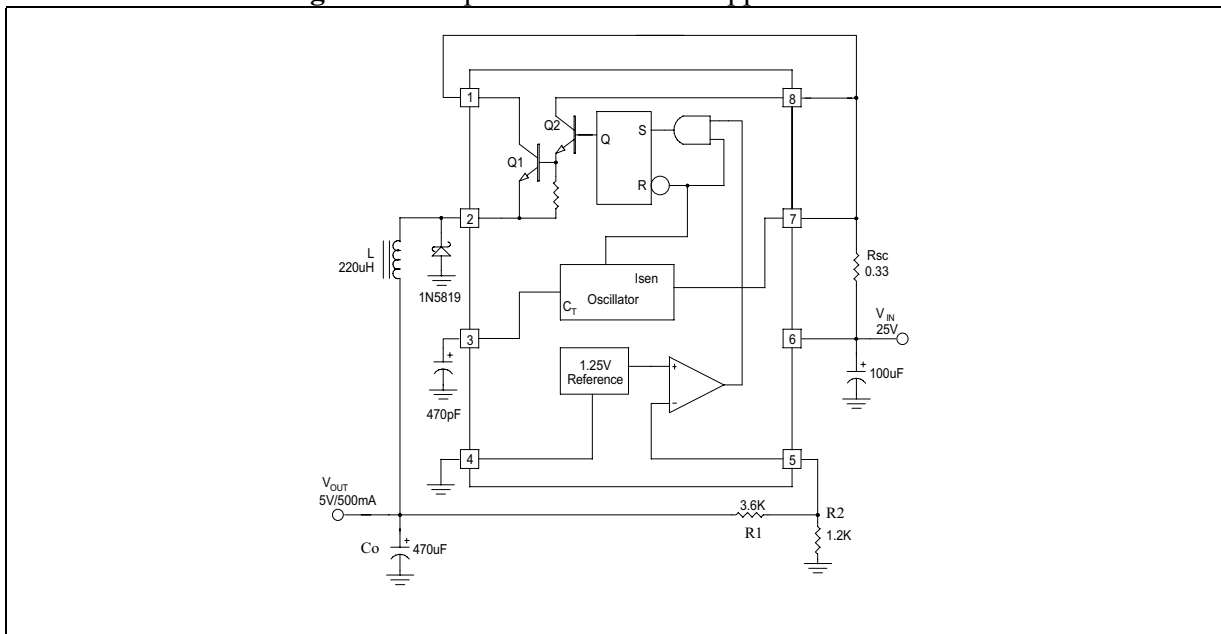
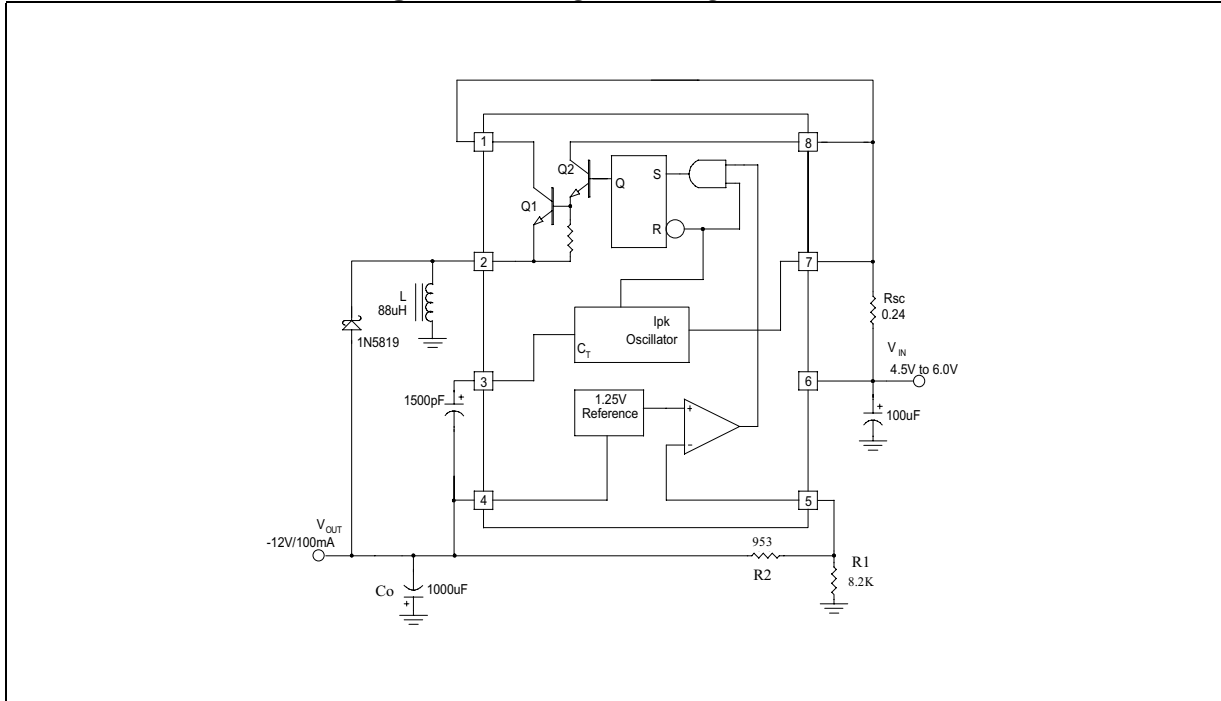

Figure 3 – Voltage Inverting Converters



Note: For step-up, step-down or voltage inverting applications requiring peak current greater than 1.5A, external boost current circuitry by NPN or PNP transistors can be used.

Typical Design Reference Table:

Calculation	Step-Down	Step-Up	Voltage-Inverting
t_{on}/t_{off}	$\frac{V_{out} + V_F}{V_{in(min)} - V_{sat} - V_{out}}$	$\frac{V_{out} + V_F - V_{in(min)}}{V_{in(min)} - V_{sat}}$	$\frac{ V_{out} + V_F}{V_{in} - V_{sat}}$
$t_{on} + t_{off}$	$\frac{1}{f}$	$\frac{1}{f}$	$\frac{1}{f}$
t_{off}	$\frac{t_{on} + t_{off}}{t_{on}/t_{off} + 1}$	$\frac{t_{on} + t_{off}}{t_{on}/t_{off} + 1}$	$\frac{t_{on} + t_{off}}{t_{on}/t_{off} + 1}$
t_{on}	$(t_{on} + t_{off}) - t_{off}$	$(t_{on} + t_{off}) - t_{off}$	$(t_{on} + t_{off}) - t_{off}$
C_T	$4.0 \times 10^{-5} t_{on}$	$4.0 \times 10^{-5} t_{on}$	$4.0 \times 10^{-5} t_{on}$
$I_{pk(switch)}$	$2I_{out(max)}$	$2I_{out(max)} (t_{on}/t_{off} + 1)$	$2I_{out(max)} (t_{on}/t_{off} + 1)$
R_{SC}	$0.3/I_{pk(switch)}$	$0.3/I_{pk(switch)}$	$0.3/I_{pk(switch)}$
$L_{(min)}$	$\left(\frac{V_{in(min)} - V_{sat} - V_{out}}{I_{pk(switch)}} \right) t_{on(max)}$	$\left(\frac{V_{in(min)} - V_{sat}}{I_{pk(switch)}} \right) t_{on(max)}$	$\left(\frac{V_{in(min)} - V_{sat}}{I_{pk(switch)}} \right) t_{on(max)}$
C_O	$\frac{I_{pk(switch)} (t_{on} + t_{off})}{8V_{ripple(pp)}}$	$9 \frac{I_{out} t_{on}}{V_{ripple(pp)}}$	$9 \frac{I_{out} t_{on}}{V_{ripple(pp)}}$

V_F : Forward Voltage drop of the output rectifier

V_{sat} : Saturation voltage of the output switch.

The following power supply characteristics must be chosen:

V_{in} - Nominal input voltage

V_{out} - Desired output voltage, $|V_{out}| = 1.25(1 + R1/R2)$

I_{out} - Desired output current.

f_{min} - Minimum desired output switching frequency at the selected values of V_{in} and I_O

$V_{ripple(pp)}$ - Desired peak - to - peak output ripple voltage.

Application concerns:

To get the best regulation performance, Low ESR capacitors at V_{out} are suggested.

AMC34063A

DC - DC CONVERTER CONTROL CIRCUITS

8-Pin Plastic DIP

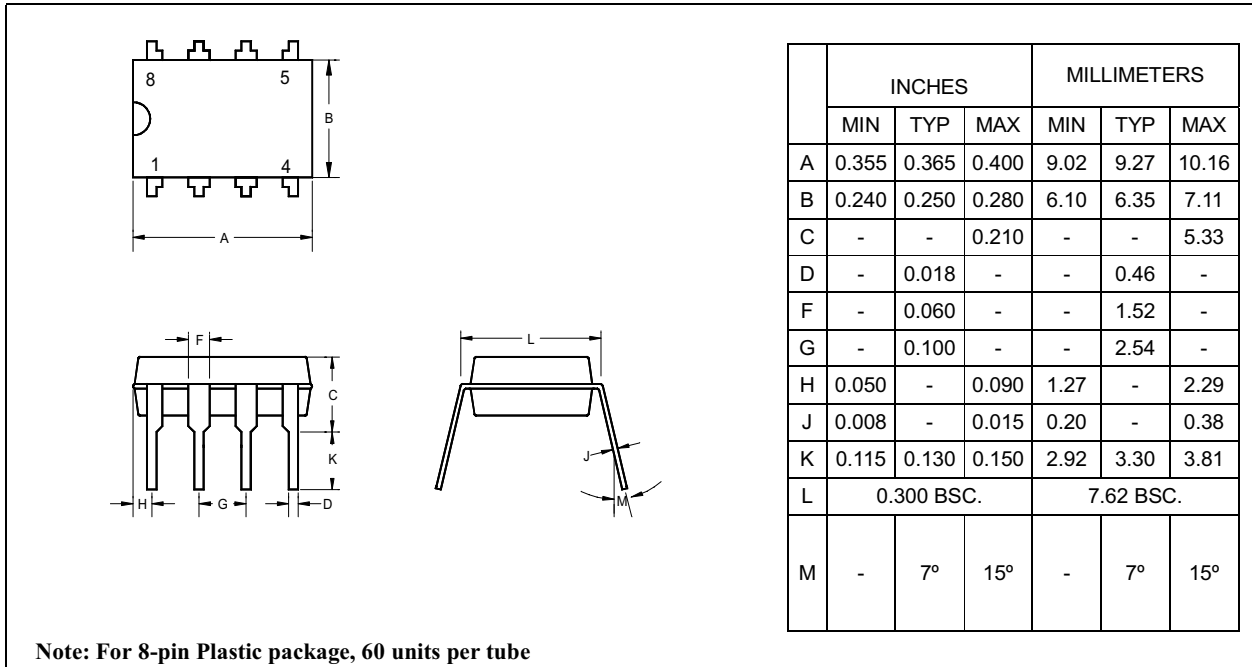

8-Pin Plastic S.O.I.C.

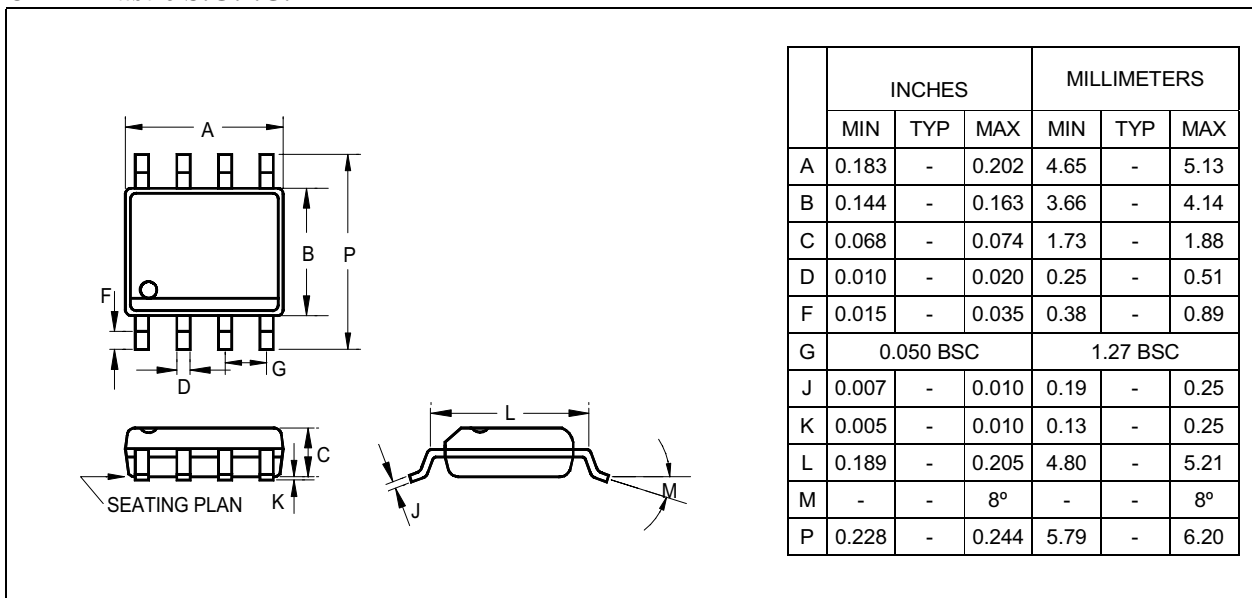

IMPORTANT NOTICE

ADD Microtech (ADDM) reserves the right to make changes to its products or to discontinue any integrated circuit product or service without notice, and advises its customers to obtain the latest version of relevant information to verify, before placing orders, that the information being relied on is current.

A few applications using integrated circuit products may involve potential risks of death, personal injury, or severe property or environmental damage. ADDM integrated circuit products are not designed, intended, authorized, or warranted to be suitable for use in life-support applications, devices or systems or other critical applications. Use of ADDM products in such applications is understood to be fully at the risk of the customer. In order to minimize risks associated with the customer's applications, the customer should provide adequate design and operating safeguards.

ADDM assumes no liability to customer product design or application support. ADDM warrants the performance of its products to the specifications applicable at the time of sale.

U.S.

ADD Microtech Inc.
492 Altamont Drive
Milpitas, CA 95035
TEL: (408) 9410420
FAX: (408) 9410864

Asia Pacific

ADD Microtech Corp
3F, 132, Sec. 4, Chung Hsiao E. Rd.,
Taipei, Taiwan
TEL: 2-27760166
FAX: 2-27764208
