

## 1.0 General Description

---

The AMIS-40616 is a full-featured local interconnect network (LIN) transceiver designed to interface between a LIN protocol controller and the physical bus. The transceiver is implemented in AMI Semiconductor's SmartPower, high-voltage, mixed-signal 0.35 $\mu$ m CMOS technology enabling both high-voltage analog circuitry and digital functionality to co-exist on the same chip.

The AMIS-40616 LIN device is a member of AMI Semiconductor's in-vehicle networking (IVN) transceiver family and integrates a LIN v2.0 physical transceiver and a 5V voltage regulator. It is designed to work in harsh automotive environments and is certified to the TS16949 qualification flow.

The LIN bus is designed to communicate low rate data from control devices such as door locks, mirrors, car seats, and sunroofs at the lowest possible cost. The bus is designed to eliminate as much wiring as possible and is implemented using a single wire in each node.

## 2.0 Key Features

---

### 2.1 LIN-Bus Transceiver

- LIN compliant to specification revision 2.0 (backwards compatible to version 1.3) and J2602
- SmartPower, high-voltage, mixed-signal 0.35 $\mu$ m CMOS technology
- Bus voltage  $\pm$  45V
- Transmission rate up to 20kBaud
- SOIC 14 Green package

### 2.2 Protection

- Thermal shutdown
- Indefinite short-circuit protection of pins LIN and WAKE to supply and ground
- Load dump protection (45V)
- Bus pins protected against transients in an automotive environment
- ESD protection level for LIN, INH, WAKE, and Vbb up to  $\pm$ 8kV

### 2.3 EMI Compatibility

- Integrated slope control

### 2.4 Voltage Regulator

- Output voltage 5V /  $\sim$ 50mA
- Wake-up input
- Enable inputs for stand-by and sleep mode
- INH output for auxiliary purposes (switching of an external pull-up or resistive divider towards battery, control of an external voltage regulator etc.)

### 2.5 Modes

- Normal mode: LIN communication with either low (up to 10kBaud) or normal slope
- Sleep mode:  $V_{CC}$  is switched "off" and no communication on LIN bus
- Stand-by mode:  $V_{CC}$  is switched "on" but there is no communication on LIN bus
- Wake-up bringing the component from sleep mode into standby mode is possible either by LIN command or digital input signal on WAKE pin. Wake-up from LIN bus can also be detected and flagged when the chip is already in standby mode.

### 3.0 Ordering Information

Table 1: Ordering Information

Marketing Name	Package	Temperature Range
AMIS40616 AGA	SOIC 150 14 GREEN (JEDEC MS-012)	-40°C...105°C

### 4.0 Key Technical Characteristics

Table 2: Key Technical Characteristics

Symbol	Parameter	Min.	Typ.	Max.	Unit
V <sub>bb</sub>	Nominal battery operating voltage	6	12	26	V
V <sub>bb</sub>	Load dump protection <sup>(1)</sup>			45	V
I <sub>bb_SLP</sub>	Supply current in sleep mode			20	μA
V <sub>cc_out</sub> <sup>(5)</sup>	Regulated V <sub>cc</sub> output in normal mode, V <sub>cc</sub> load 1mA-30mA	4.9	5.0	5.1	V
	Regulated V <sub>cc</sub> output in normal mode, V <sub>cc</sub> load 0mA-50mA	4.83	5.0	5.17	V
	Regulated V <sub>cc</sub> output in standby mode, V <sub>cc</sub> load 0mA-50mA	4.8	5.0	5.2	V
I <sub>out_max</sub>	Maximum continuous V <sub>cc</sub> output current <sup>(2)</sup>	30			mA
	Maximum V <sub>cc</sub> output current, thermal shutdown can occur <sup>(2)</sup>	50			mA
V <sub>wake</sub>	Operating DC voltage on WAKE pin	0		V <sub>bb</sub>	V
	Maximum rating voltage on WAKE pin	-45		V <sub>bb</sub> + 0.3	V
T <sub>j</sub>	Junction thermal shutdown temperature	165		195	°C
T <sub>amb</sub>	Operating ambient temperature	-40		+105	°C
V <sub>esd</sub>	Electrostatic discharge voltage (LIN, INH, WAKE, VBB) System HBM <sup>(3)</sup>	-8		+8	kV
	Electrostatic discharge voltage (LIN, INH, WAKE, VBB) HBM <sup>(4)</sup>	-4		+4	kV
	Electrostatic discharge voltage (other pins) HBM <sup>(4)</sup>	-2		+2	kV

- Notes:**
1. The applied transients shall be in accordance with ISO 7637 part 1, test pulse 5. The device complies with functional class C; class A can be reached depending on the application and external components.
  2. Current limitation is set above 50mA but thermal shutdown can occur for currents above 30mA.
  3. Equivalent to discharging a 150pF capacitor through a 330Ω resistor conform to IEC Standard 1000-4-2. The specified values are a target to be verified on first prototypes. Based on the evaluation results, additional external protection components might be recommended to reach the specified system ESD levels.
  4. Equivalent to discharging a 100pF capacitor through a 1.5kΩ resistor conform to MIL STD 883 method 3015.7.
  5. V<sub>cc</sub> voltage must be properly stabilized by external capacitors: capacitor of min. 80nF with ESR<10mΩ in parallel with a capacitor of min. 8μF, ESR<1Ω.

### 5.0 Block Diagram

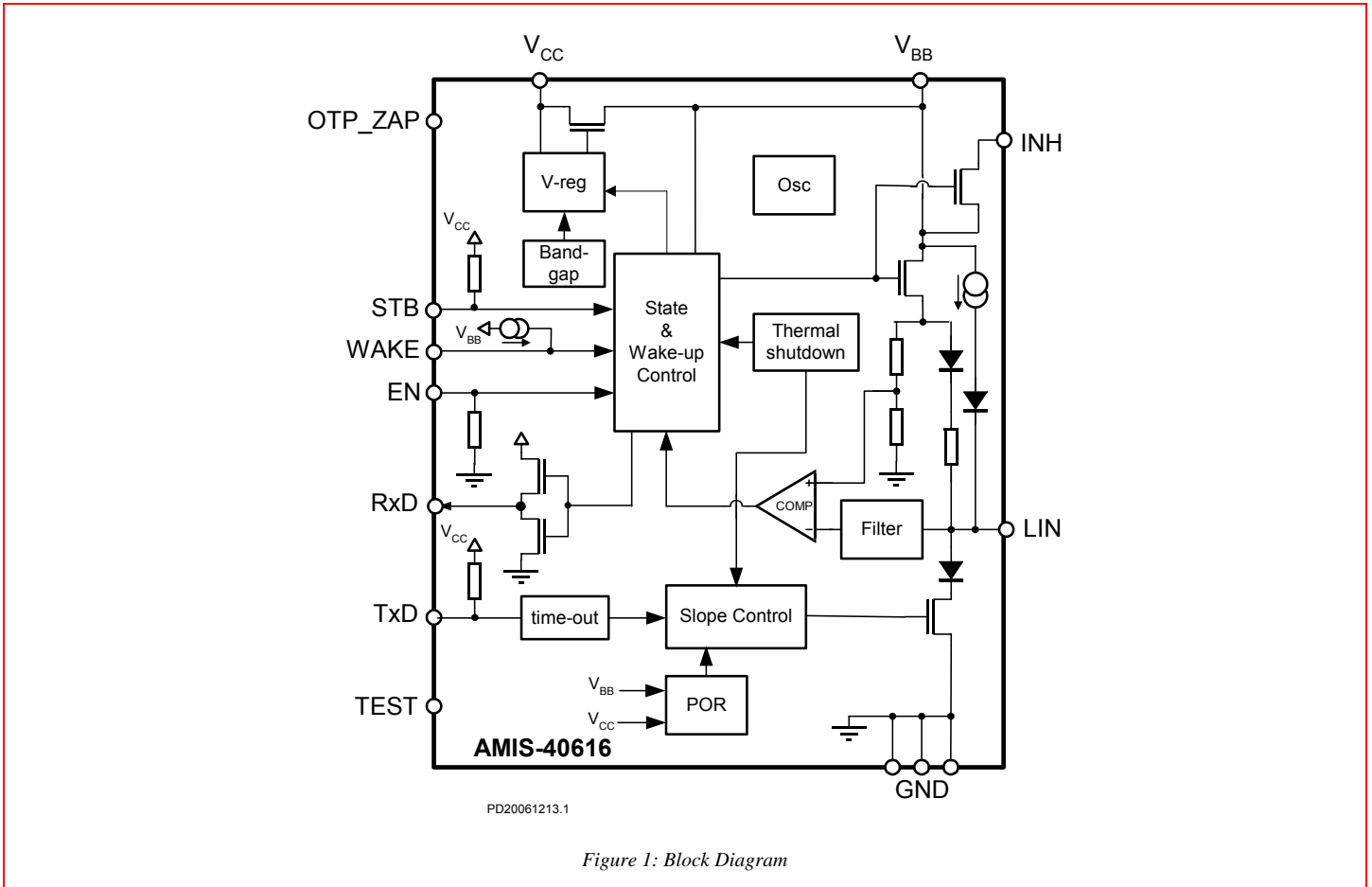

Figure 1: Block Diagram

### 6.0 Typical Application

#### 6.1 Application Schematic

The EMC immunity of the master-mode device can be further enhanced by adding a capacitor between the LIN output and ground. The optimum value of this capacitor is determined by the length and capacitance of the LIN bus, the number and capacitance of slave devices, the pull-up resistance of all devices (master & slave), and the required time constant of the system, respectively.

V<sub>CC</sub> voltage must be properly stabilized by external capacitors: capacitor of min. 80nF (ESR<10mΩ) in parallel with a capacitor of min. 8μF (ESR<1Ω).

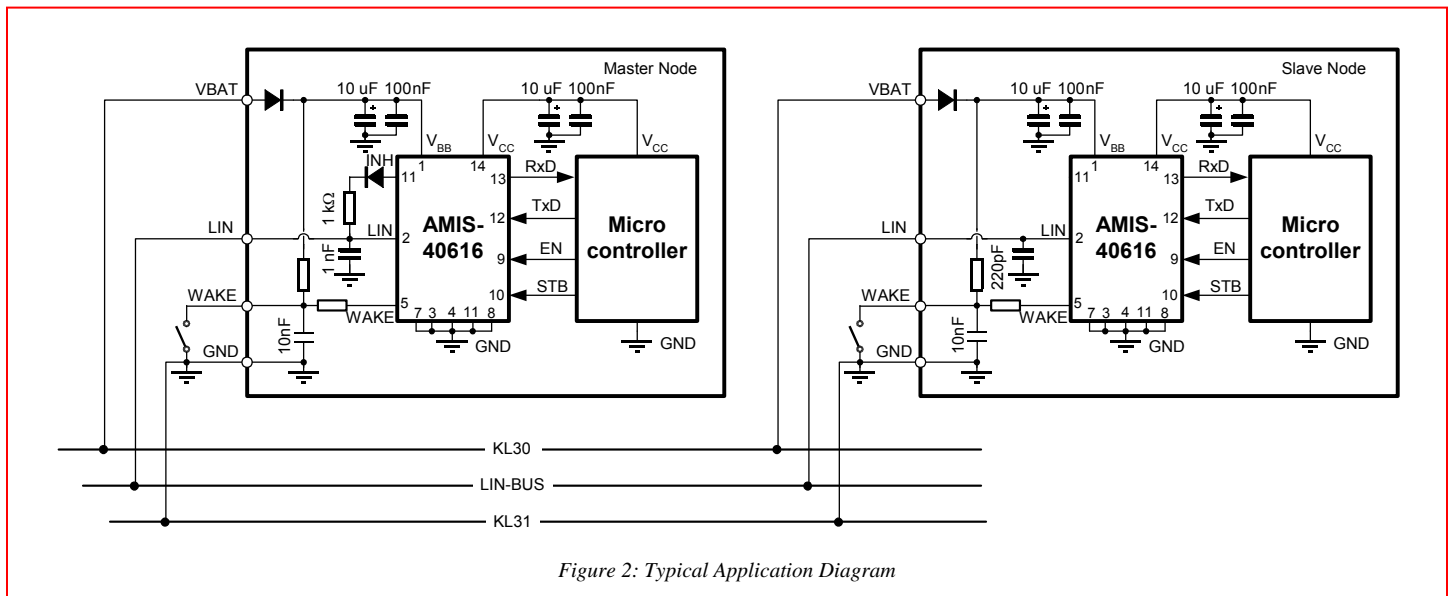

#### 6.2 Pin Description

##### 6.2.1. Pin Out (top view)

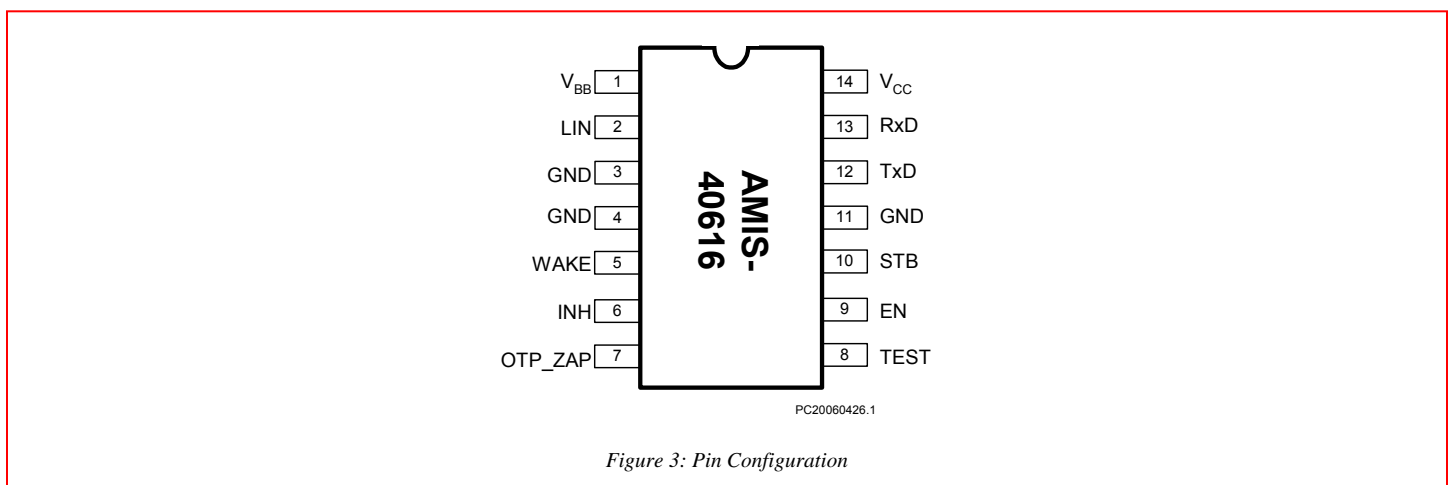

# AMIS-40616

## LIN Transceiver with 5V Voltage Regulator

### 6.2.2. Pin Description

Table 3: Pin Description

Pin	Name	Description
1	VBB	Battery supply input
2	LIN	LIN bus output/input
3	GND	Ground
4	GND	Ground
5	WAKE	High voltage digital input pin to switch the part from sleep- to stand-by-mode
6	INH	Inhibit output
7	OTP_ZAP	Supply for programming of trimming bits at factory testing, should be grounded in the application
8	TEST	Digital input for factory testing, should be grounded in the application
9	EN	Enable input, transceiver in normal operation mode when high
10	STB	Standby mode control input
11	GND	Ground
12	TxD	Transmit data input, low in dominant state
13	RxD	Receive data output; low in dominant state; push-pull output
14	Vcc	Supply voltage (output)

## 7.0 Functional Description

### 7.1 Overall Functional Description

LIN is a serial communication protocol that efficiently supports the control of mechatronic nodes in distributed automotive applications. The domain is class-A multiplex buses with a single master node and a set of slave nodes.

AMIS-40616 is designed as a master or slave node for the LIN communication interface with integrated 5V voltage regulator having a current capability up to 50mA for supplying any external components (microcontroller).

AMIS-40616 contains the LIN transmitter, LIN receiver, voltage regulator, power-on-reset (POR) circuits and thermal shutdown (TSD). The LIN transmitter is optimized for the maximum specified transmission speed of 20kBaud with EMC performance due to reduced slew rate of the LIN output.

The junction temperature is monitored via a thermal shutdown circuit that switches the LIN transmitter and voltage regulator off when temperature exceeds the TSD trigger level.

AMIS-40616 has four operating states (normal mode, low slope mode, stand-by mode, and sleep mode) that are determined by the input signals EN, WAKE, STB, and TxD.

### 7.2 Operating States

AMIS-40616 provides four operating states, two modes for normal operation with communication, one stand-by without communication and one low power mode with very low current consumption. See Figure 4.

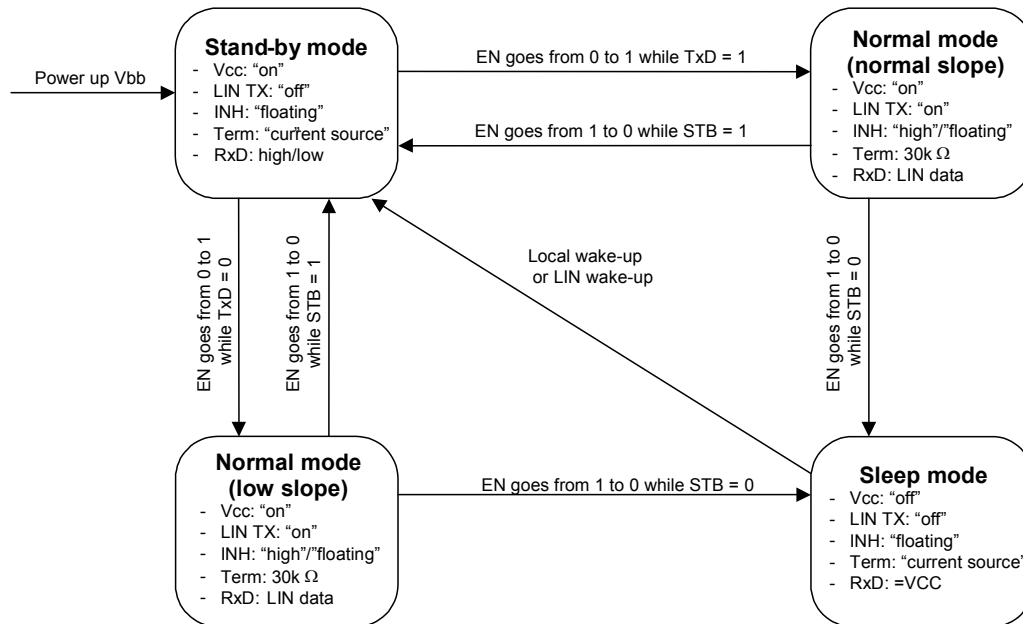

Figure 4: State Diagram

Table 4: Mode Selection

Mode	Vcc	RxD	INH	LIN	30kΩ on LIN	Note
Normal - Slope	On	Low = dominant state High = recessive state	High if STB = High during state transition; floating otherwise	Normal slope	On	(1)
Normal - Low Slope	On	Low = dominant state High = recessive state	High if STB = High during state transition; floating otherwise	Low slope	On	(2)
Stand-by	On	Low after LIN wake-up, high otherwise	Floating	Off	Off	(3)
Sleep	Off	Clamped to V <sub>cc</sub>	Floating	Off	Off	

- Notes:**
1. The normal slope mode is entered when pin EN goes high while TxD is in high state during EN transition.
  2. The low slope mode is entered when pin EN goes high while TxD is in low state during EN transition. LIN transmitter gets on only after TxD returns to high after the state transition.
  3. The stand-by mode is entered automatically after power-up.

### 7.2.1. Normal Slope Mode

In normal slope mode the transceiver can transmit and receive data via LIN bus with speed up to 20kBaud. The transmit data stream of the LIN protocol is present on the TxD pin and converted by the transmitter into a LIN bus signal with controlled slew rate to minimize EMC emission. The receiver consists of the comparator that has a threshold with hysteresis in respect to the supply voltage and an input filter to remove bus noise. The LIN output is pulled high via an internal 30kΩ pull-up resistor. For master applications it is needed to put an external 1kΩ resistor with a serial diode between LIN and V<sub>bb</sub> (or INH). See Figure 2. The mode selection is done by EN=HIGH when TxD pin is high. If STB pin is high during the standby-to-normal slope mode transition, INH pin is pulled high. Otherwise, it stays floating.

### 7.2.2. Low Slope Mode

In low slope mode the slew rate of the signal on the LIN bus is reduced (rising and falling edges of the LIN bus signal are longer). This further reduces the EMC emission. As a consequence the maximum speed on the LIN bus is reduced up to 10kBaud. This mode is suited for applications where the communication speed is not critical. The mode selection is done by EN=HIGH when TxD pin is low. In order not to transmit immediately a dominant state on the bus (because TxD=LOW), the LIN transmitter is enabled only after TxD returns to high. If STB pin is high during the standby-to-low slope mode transition, INH pin is pulled high. Otherwise, it stays floating.

### 7.2.3. Stand-by Mode

The stand-by mode is always entered after power-up of the AMIS-40616. It can also be entered from normal mode when the EN pin is low and the stand-by pin is high. From sleep mode it can be entered after a local wake-up or LIN wakeup. In stand-by mode the V<sub>cc</sub> voltage regulator for supplying external components (e.g. a microcontroller) stays active. Also the LIN receiver stays active to be able to detect a remote wake-up via bus. The LIN transmitter is disabled and the slave internal termination resistor of 30kΩ between LIN and V<sub>bb</sub> is disconnected in order to minimize current consumption. Only a pull-up current source between V<sub>bb</sub> and LIN is active.

### 7.2.4. Sleep Mode

The sleep mode provides extreme low current consumption. This mode is entered when both EN and STB pins are low coming from normal mode. The internal termination resistor of 30kΩ between LIN and V<sub>bb</sub> is disconnected and also the V<sub>cc</sub> regulator is switched off to minimize current consumption.

### 7.2.5. Wake-up

AMIS-40616 has two possibilities to wake-up from sleep or stand-by mode (see Figure 4):

- Local wake-up: enables the transition from sleep mode to stand-by mode.
- Remote wake-up via LIN: enables the transition from sleep- to stand-by mode and can be also detected when already in standby mode.

A local wake-up is **only** detected in sleep mode if a transition from low to high or from high to low is seen on the wake pin.

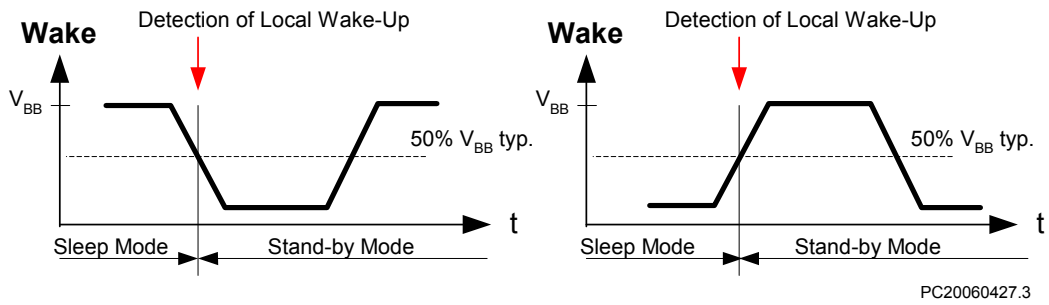

Figure 5: Local Wake-up Signal

A remote wake-up is **only** detected if a combination of (1) a falling edge at the LIN pin (transition from recessive to dominant) is followed by (2) a dominant level maintained for a time period  $> t_{WAKE}$  and (3) again a rising edge at pin LIN (transition from dominant to recessive) happens.

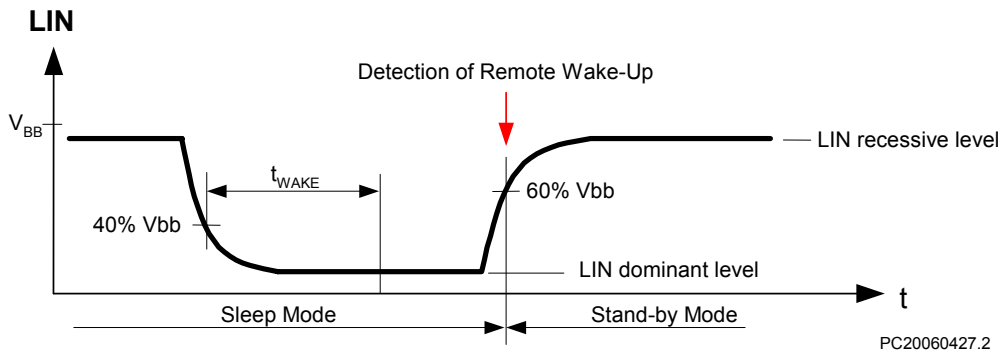

Figure 6: Remote Wake-up Behavior

The wake-up source is distinguished by pin RxD in the stand-by mode:

- RxD remains high after power-up or local wake-up.
- RxD is kept low until normal mode is entered after a remote wake-up (LIN).



### 8.0 Electrical Characteristics

#### 8.1 Definitions

All voltages are referenced to GND (Pin 13). Positive currents flow into the IC.

#### 8.2 Absolute Maximum Ratings

Stresses above those listed in this clause may cause permanent device failure. Exposure to absolute maximum ratings for extended periods may affect device reliability.

Table 5: Absolute Maximum Ratings

Symbol	Parameter	Min.	Max.	Unit
V <sub>bb</sub>	Battery voltage on pin V <sub>bb</sub> <sup>(1)</sup>	-0.3	+45	V
V <sub>cc</sub>	DC voltage on pin V <sub>cc</sub>	0	+7	V
I <sub>Vcc</sub>	Current delivered by the V <sub>cc</sub> regulator	50		mA
V <sub>LIN</sub>	LIN bus voltage <sup>(2)</sup>	-40	+45	V
V <sub>INH</sub>	DC voltage on inhibit pin	-0.3	V <sub>bb</sub> + 0.3	V
V <sub>WAKE</sub>	DC voltage on WAKE pin	-45	V <sub>bb</sub> + 0.3	V
V <sub>Dig_in</sub>	DC input voltage on pins TxD, RxD, EN, STB	-0.3	V <sub>cc</sub> + 0.3	V
T <sub>junc</sub>	Maximum junction temperature	-40	+165	°C
V <sub>esd</sub>	Electrostatic discharge voltage (pins LIN, INH, WAKE, and V <sub>bb</sub> ) system HBM <sup>(3)</sup>	-8	+8	kV
	Electrostatic discharge voltage (pins LIN, INH, WAKE, and V <sub>bb</sub> ) HBM <sup>(4)</sup>	-4	+4	kV
	Electrostatic discharge voltage (other pins) HBM <sup>(4)</sup>	-2.0	+2.0	kV
	Electrostatic discharge voltage; charge device model <sup>(5)</sup>	-250	+250	V

- Notes:**
- The applied transients shall be in accordance with ISO 7637 part 1, test pulses 1, 2, 3a, 3b, and 5. The device complies with functional class C; class A can be reached depending on the application and external components.
  - The applied transients shall be in accordance with ISO 7637 part 1, test pulses 1, 2, 3a, and 3b. The device complies with functional class C; class A can be reached depending on the application and external components.
  - Equivalent to discharging a 150pF capacitor through a 330Ω resistor conform to IEC Standard 1000-4-2. The specified values are a target to be verified on first prototypes. Based on the evaluation results, additional external protection components might be recommended to reach the specified system ESD levels.
  - Equivalent to discharging a 100pF capacitor through a 1.5k Ω resistor conform to MIL STD 883 method 3015.7.
  - Conform to EOS/ESD-DS5.3 (socket mode).

#### 8.3 DC Characteristics

V<sub>BB</sub> = 6V to 26V; T<sub>junc</sub> = -40°C to +150°C; unless otherwise specified.

Table 6: DC Characteristics Supply

Symbol	Parameter	Conditions	Min.	Typ.	Max.	Unit
<b>Pins VBB and VCC</b>						
I <sub>bb_ON</sub>	Supply current	Normal mode; LIN recessive			1	mA
I <sub>bb_STB</sub>	Supply current	Stand-by mode, V <sub>bb</sub> = 6 – 18V			60	µA
I <sub>bb_SLP</sub>	Supply current	Sleep mode, V <sub>bb</sub> = 6 – 18V			20	µA
V <sub>cc_out</sub>	Regulator output voltage	Normal mode, V <sub>cc</sub> load 1mA-30mA	4.9	5.0	5.1	V
	Regulator output voltage	Normal mode, V <sub>cc</sub> load 0mA-50mA	4.83	5.0	5.17	V
	Regulator output voltage	Stand-by mode, V <sub>cc</sub> load 0mA-50mA	4.8	5.0	5.2	V
I <sub>out_max_cont</sub>	Maximum output current	V <sub>bb</sub> = 16V; T <sub>amb</sub> = 105°C			30	mA
I <sub>out_max_conta</sub>	Maximum output current	V <sub>bb</sub> = 26V; limited lifetime			30	mA
I <sub>out_max_abs</sub>	Absolute maximum output current	Thermal shutdown can occur			50	mA
I <sub>out_lim</sub>	Over-current limitation		50		150	mA

# AMIS-40616

## LIN Transceiver with 5V Voltage Regulator

Table 7: DC Characteristics LIN Transmitter

Symbol Pin LIN	Parameter	Conditions	Min.	Typ.	Max.	Unit
VLin_dom_LoSup	LIN dominant output voltage	TXD = low; V <sub>bb</sub> = 7.3V			1.2	V
VLin_dom_HiSup	LIN dominant output voltage	TXD = low; V <sub>bb</sub> = 18V			2.0	V
VLin_rec	LIN recessive output voltage	TXD = high; I <sub>lin</sub> = 0mA		V <sub>bb</sub> - V <sub>γ</sub> <sup>(1)</sup>		V
ILIN_lim	Short circuit current limitation	VLin = V <sub>bb_max</sub>	40		130	mA
Rslave	Internal pull-up resistance		20	33	47	kΩ
ILIN_off_dom	LIN output current bus in dominant state	Driver off; V <sub>bb</sub> = 12V	-1			mA
ILIN_off_rec	LIN output current bus in recessive state	Driver off; V <sub>bb</sub> = 12V			20	μA
ILIN_no_GND	Communication not affected	V <sub>bb</sub> = GND = 12V; 0 < VLin < 18V	-1		1	mA
ILIN_no_Vbb	LIN bus remains operational	V <sub>bb</sub> = GND = 0V; 0 < VLin < 18V			100	μA

**Note:**

- V<sub>γ</sub> is the forward diode voltage. Typically (over the complete temperature) V<sub>γ</sub> = 1V.

Table 8: DC Characteristics LIN Receiver

Symbol Pin LIN	Parameter	Conditions	Min.	Typ.	Max.	Unit
Vrec_dom	Receiver threshold	LIN bus recessive → dominant	0.4		0.6	V <sub>bb</sub>
Vrec_rec	Receiver threshold	LIN bus dominant → recessive	0.4		0.6	V <sub>bb</sub>
Vrec_cnt	Receiver center voltage	(V <sub>bus_dom</sub> + V <sub>bus_rec</sub> ) / 2	0.475		0.525	V <sub>bb</sub>
Vrec_hys	Receiver hysteresis		0.05		0.175	V <sub>bb</sub>

Table 9: DC Characteristics I/Os

Symbol Pin WAKE	Parameter	Conditions	Min.	Typ.	Max.	Unit
V_wake_th	Threshold voltage		0.35		0.65	V <sub>bb</sub>
I_leak	Input leakage current <sup>(1)</sup>	Vwake = 0V; V <sub>bb</sub> = 18V	-1	-0.5	1	μA
T_wake_min	Debounce time	Sleep mode; rising and falling edge	8		54	μs
<b>Pins TxD and STB</b>						
Vil	Low level input voltage		0		0.3	V <sub>cc</sub>
Vih	High level input voltage		0.7		1	V <sub>cc</sub>
Rpu	Pull-up resistance to V <sub>cc</sub> <sup>(1)</sup>		50		200	kΩ
<b>Pin INH</b>						
Delta_VH	High level voltage drop	IINH = 15mA		0.35	0.75	V
I_leak	Leakage current	Sleep mode; VINH = 0V	-1		1	μA
<b>Pin EN</b>						
Vil	Low level input voltage		0		0.3	V <sub>cc</sub>
Vih	High level input voltage		0.7		1	V <sub>cc</sub>
Rpd	Pull-down resistance to ground <sup>(1)</sup>		50		200	kΩ
<b>Pin RxD</b>						
Vol	Low level output voltage	I <sub>sink</sub> = 2mA	0		0.2	V <sub>cc</sub>
Voh	High level output voltage	I <sub>source</sub> = -2mA	0.8		1	V <sub>cc</sub>

**Note:**

- By one of the trimming bits, following reconfiguration can be done during chip-level testing in order to fit the AMIS-40616 into different interface: pins TxD, EN and STB will have typ. 10kΩ pull-down resistor to ground and pin WAKE will have typ. 10μA pull-down current source.

Table 10: DC Characteristics

Symbol POR	Parameter	Conditions	Min.	Typ.	Max.	Unit
PORH_Vbb	POR high level V <sub>bb</sub> comparator				4.5	V
PORL_Vbb	POR low level V <sub>bb</sub> comparator		3			V
POR_Vbb_hyst	Hysteresis of POR level V <sub>bb</sub> comparator		100			mV
POR_Vbb_sl	Maximum slope on V <sub>bb</sub> to guarantee POR				50	V/ms
PORH_Vcc	POR high level V <sub>cc</sub> comparator				3	V
PORL_Vcc	POR low level V <sub>cc</sub> comparator		2			V
POR_Vcc_hyst	Hysteresis of POR level V <sub>cc</sub> comparator		100			mV
<b>TSD</b>						
Tj	Junction temperature	For shutdown	165		195	°C
Tj_hyst	Thermal shutdown hysteresis		9		18	°C

### 8.4 AC Characteristics

$V_{BB} = 7V$  to  $18V$ ;  $T_{junc} = -40^{\circ}C$  to  $+150^{\circ}C$ ; unless otherwise specified.

Table 11: AC Characteristics LIN Transmitter

Symbol Pin LIN	Parameter	Conditions	Min.	Typ.	Max.	Unit
D1	Duty cycle 1 = $t_{BUS\_REC(min)} / (2 \times T_{Bit})$	$TH_{REC(min)} = 0.284 \times V_{bb}$ $TH_{DOM(min)} = 0.422 \times V_{bb}$ $T_{Bit} = 50\mu s$	0.396			
D2	Duty cycle 2 = $t_{BUS\_REC(max)} / (2 \times T_{Bit})$	$TH_{REC(max)} = 0.744 \times V_{bb}$ $TH_{DOM(max)} = 0.581 \times V_{bb}$ $T_{Bit} = 50\mu s$			0.581	
T_fall_norm	LIN falling edge	Normal slope mode; $V_{bb} = 12V$ ; L1, L2 <sup>(1)</sup>			22.5	$\mu s$
T_rise_norm	LIN rising edge	Normal slope mode; $V_{bb} = 12V$ ; L1, L2 <sup>(1)</sup>			22.5	$\mu s$
T_sym_norm	LIN slope symmetry	Normal slope mode; $V_{bb} = 12V$ ; L1, L2 <sup>(1)</sup>	-4		4	$\mu s$
T_fall_norm	LIN falling edge	Normal slope mode; $V_{bb} = 12V$ ; L3 <sup>(1)</sup>			27	$\mu s$
T_rise_norm	LIN rising edge	Normal slope mode; $V_{bb} = 12V$ ; L3 <sup>(1)</sup>			27	$\mu s$
T_sym_norm	LIN slope symmetry	Normal slope mode; $V_{bb} = 12V$ ; L3 <sup>(1)</sup>	-5		5	$\mu s$
T_fall_low	LIN falling edge	Low slope mode <sup>(2)</sup> ; $V_{bb} = 12V$ ; L3 <sup>(1)</sup>			62	$\mu s$
T_rise_low	LIN rising edge	Low slope mode <sup>(2)</sup> ; $V_{bb} = 12V$ ; L3 <sup>(1)</sup>			62	$\mu s$
T_wake	Dominant time-out for wake-up via LIN bus		30		150	$\mu s$
T_dom	TxD dominant time-out	TxD = low	6		20	ms

**Notes:**

1. The AC parameters are specified for following RC loads on the LIN bus: L1 =  $1k\Omega / 1nF$ ; L2 =  $660\Omega / 6.8nF$ ; L3 =  $500\Omega / 10nF$ .
2. Low slope mode is not compliant to the LIN 1.3 or LIN 2.0 standard.

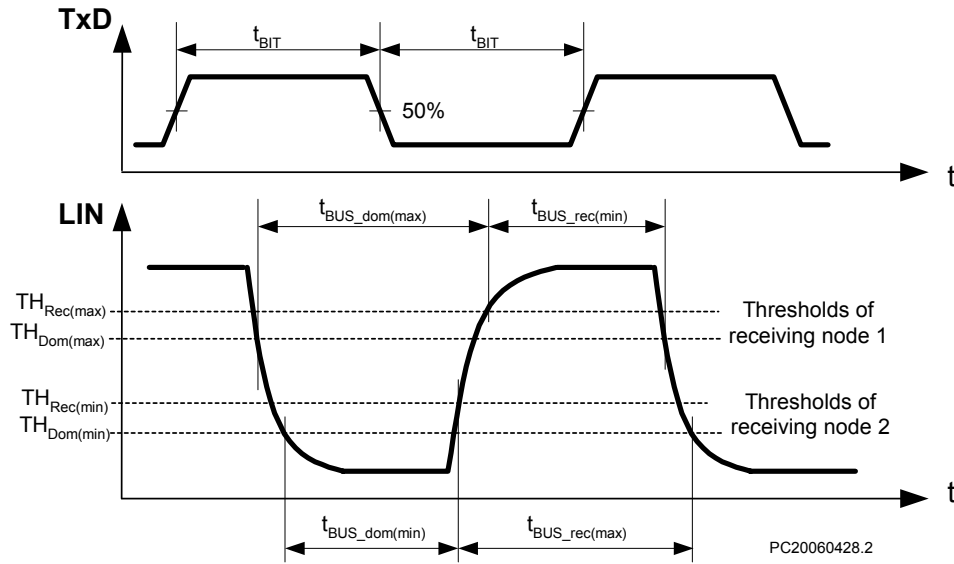

Figure 7: LIN Transmitter Duty Cycle

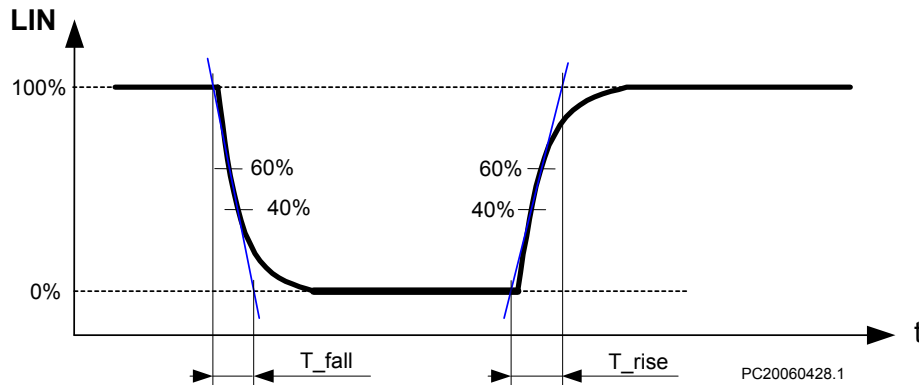

Figure 8: LIN Transmitter Rising and Falling Times

Table 12: AC Characteristics LIN Receiver

Symbol	Parameter	Conditions	Min.	Typ.	Max.	Unit
Pin LIN						
Trec_prop_down	Propagation delay of receiver falling edge		0.1		6	$\mu\text{s}$
Trec_prop_up	Propagation delay of receiver rising edge		0.1		6	$\mu\text{s}$
Trec_sym	Propagation delay symmetry	Trec_prop_down - Trec_prop_up	-2		2	$\mu\text{s}$

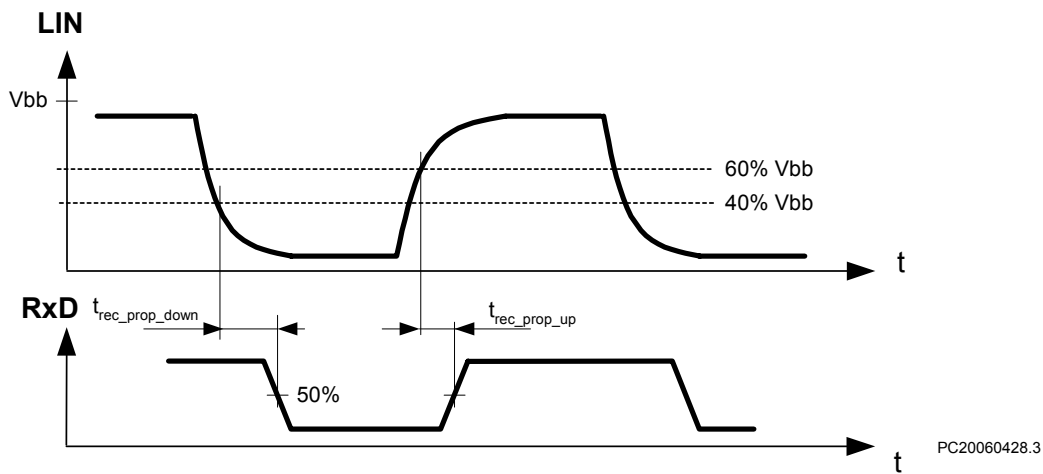

Figure 9: LIN Receiver Timing

# AMIS-40616

## LIN Transceiver with 5V Voltage Regulator

### 9.0 Package Outline

SOIC-14: Plastic small outline; 14 leads; body width 150mil; JEDEC: MS-012

AMIS reference: SOIC150 14 150 G

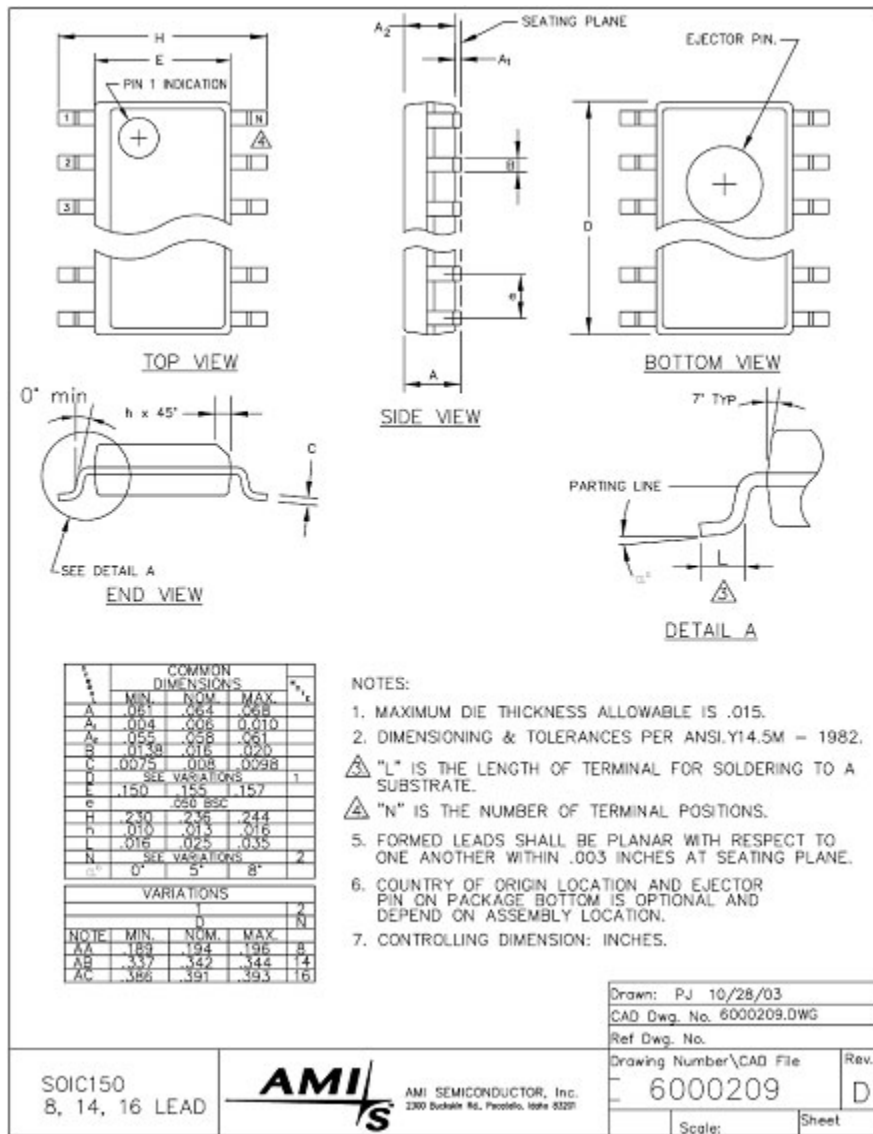

## 10.0 Soldering

---

### 10.1 Introduction to Soldering Surface Mount Packages

This text gives a very brief insight to a complex technology. A more in-depth account of soldering ICs can be found in the AMIS “Data Handbook IC26; Integrated Circuit Packages” (document order number 9398 652 90011). There is no soldering method that is ideal for all surface mount IC packages. Wave soldering is not always suitable for surface mount ICs, or for printed-circuit boards (PCBs) with high population densities. In these situations re-flow soldering is often used.

### 10.2 Re-flow Soldering

Re-flow soldering requires solder paste (a suspension of fine solder particles, flux and binding agent) to be applied to the PCB by screen printing, stenciling or pressure-syringe dispensing before package placement. Several methods exist for re-flowing; for example, infrared/convection heating in a conveyor type oven. Throughput times (preheating, soldering and cooling) vary between 100 and 200 seconds depending on heating method. Typical re-flow peak temperatures range from 215 to 260°C.

### 10.3 Wave Soldering

Conventional single wave soldering is not recommended for surface mount devices (SMDs) or PCBs with a high component density, as solder bridging and non-wetting can present major problems. To overcome these problems the double-wave soldering method was specifically developed.

If wave soldering is used the following conditions must be observed for optimal results:

- Use a double-wave soldering method comprising a turbulent wave with high upward pressure followed by a smooth laminar wave.
- For packages with leads on two sides and a pitch (e):
  - Larger than or equal to 1.27mm, the footprint longitudinal axis is preferred to be parallel to the transport direction of the PCB;
  - Smaller than 1.27mm, the footprint longitudinal axis must be parallel to the transport direction of the PCB. The footprint must incorporate solder thieves at the downstream end.
- For packages with leads on four sides, the footprint must be placed at a 45° angle to the transport direction of the PCB. The footprint must incorporate solder thieves downstream and at the side corners.

During placement and before soldering, the package must be fixed with a droplet of adhesive. The adhesive can be applied by screen printing, pin transfer or syringe dispensing. The package can be soldered after the adhesive is cured. Typical dwell time is four seconds at 250°C. A mildly-activated flux will eliminate the need for removal of corrosive residues in most applications.

### 10.4 Manual Soldering

Fix the component by first soldering two diagonally-opposite end leads. Use a low voltage (24V or less) soldering iron applied to the flat part of the lead. Contact time must be limited to 10 seconds at up to 300°C.

When using a dedicated tool, all other leads can be soldered in one operation within two to five seconds between 270 and 320°C.

# AMIS-40616

## LIN Transceiver with 5V Voltage Regulator

Table 13: Soldering Process

Package	Soldering Method	
	Wave	Re-flow <sup>(1)</sup>
BGA, SQFP	Not suitable	Suitable
HLQFP, HSQFP, HSOP, HTSSOP, SMS	Not suitable <sup>(2)</sup>	Suitable
PLCC <sup>(3)</sup> , SO, SOJ	Suitable	Suitable
LQFP, QFP, TQFP	Not recommended <sup>(3)(4)</sup>	Suitable
SSOP, TSSOP, VSO	Not recommended <sup>(5)</sup>	Suitable

- Notes:**
- All SMD packages are moisture sensitive. Depending upon the moisture content, the maximum temperature (with respect to time) and body size of the package, there is a risk that internal or external package cracks may occur due to vaporization of the moisture in them (the so called popcorn effect). For details, refer to the dry pack information in the "Data Handbook IC26; Integrated Circuit Packages; Section: Packing Methods".
  - These packages are not suitable for wave soldering as a solder joint between the PCB and heat sink (at bottom version) can not be achieved, and as solder may stick to the heat sink (on top version).
  - If wave soldering is considered, then the package must be placed at a 45° angle to the solder wave direction. The package footprint must incorporate solder thieves downstream and at the side corners.
  - Wave soldering is only suitable for LQFP, TQFP and QFP packages with a pitch (e) equal to or larger than 0.8mm; it is definitely not suitable for packages with a pitch (e) equal or smaller than 0.65mm.
  - Wave soldering is only suitable for SSOP and TSSOP packages with a pitch (e) equal to or larger than 0.65mm; it is definitely not suitable for packages with a pitch (e) equal to or smaller than 0.5mm.

## 11.0 Revision History

Table 14: Revision History

Revision	Date	Format	Description
1.0	24 May 2006	Preliminary	Initial document
1.1	9 August 2006	Preliminary	Major update according AMIS40615
1.6	18 January 2007	Preliminary	<ul style="list-style-type: none"> <li>▪ major update according AMIS40616</li> <li>▪ version numbering aligned with AMIS40615</li> </ul>



### 12.0 Company or Product Inquiries

---

For more information about AMI Semiconductor's LIN transceivers, send an email to [auto\\_assp@amis.com](mailto:auto_assp@amis.com).

For more information about AMI Semiconductor's products or services visit our Web site at <http://www.amis.com>.

Devices sold by AMIS are covered by the warranty and patent indemnification provisions appearing in its Terms of Sales only. AMIS makes no warranty, express, statutory, implied or by description, regarding the information set forth herein or regarding the freedom of the described from patent infringement. AMIS makes no warranty of merchantability or fitness for any purposes. AMIS reserves the right to discontinue production and change specifications and prices at any time and without notice. AMI Semiconductor's products are intended for use in commercial applications. Applications requiring extended temperature range, unusual environmental requirements, or high reliability applications, such as military, medical life-support or life-sustaining equipment, are specifically not recommended without additional processing by AMIS for such applications. Copyright© 2007 AMI Semiconductor, Inc.