

## Triple dual Common Source NPT IGBT Power Module

$V_{CES} = 600V$   
 $I_C = 90A @ T_c = 80^\circ C$

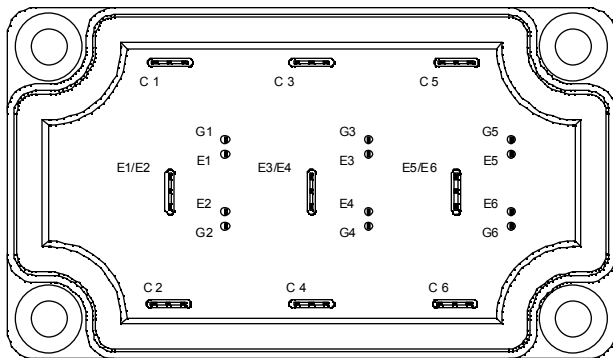
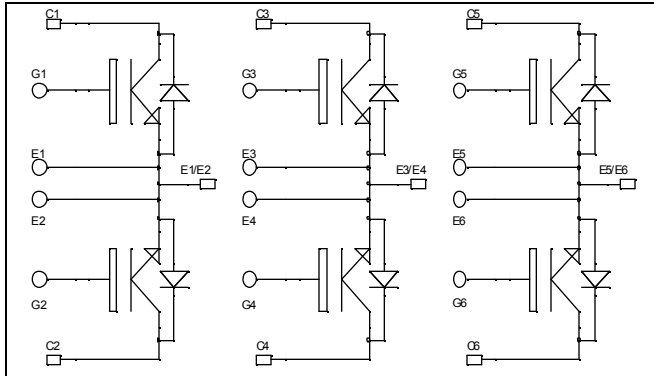

### Application

- AC Switches
- Switched Mode Power Supplies
- Uninterruptible Power Supplies

### Features

- Non Punch Through (NPT) THUNDERBOLT IGBT®
  - Low voltage drop
  - Low tail current
  - Switching frequency up to 100 kHz
  - Soft recovery parallel diodes
  - Low diode VF
  - Low leakage current
  - Avalanche energy rated
  - RBSOA and SCSOA rated
- Kelvin emitter for easy drive
- Very low stray inductance
  - Symmetrical design
  - Lead frames for power connections
- High level of integration

### Benefits

- Outstanding performance at high frequency operation
- Direct mounting to heatsink (isolated package)
- Low junction to case thermal resistance
- Solderable terminals both for power and signal for easy PCB mounting
- Very low (12mm) profile
- Easy paralleling due to positive TC of VCEsat
- Each leg can be easily paralleled to achieve a dual common source configuration of three times the current capability

### Absolute maximum ratings

Symbol	Parameter	Max ratings	Unit
$V_{CES}$	Collector - Emitter Breakdown Voltage	600	V
$I_C$	Continuous Collector Current	$T_c = 25^\circ C$	110
		$T_c = 80^\circ C$	90
$I_{CM}$	Pulsed Collector Current	$T_c = 25^\circ C$	315
$V_{GE}$	Gate - Emitter Voltage	$\pm 20$	V
$P_D$	Maximum Power Dissipation	$T_c = 25^\circ C$	416
RBSOA	Reverse Bias Safe Operating Area	$T_j = 150^\circ C$	315A @ 600V

 **CAUTION:** These Devices are sensitive to Electrostatic Discharge. Proper Handling Procedures Should Be Followed.

All ratings @  $T_j = 25^\circ\text{C}$  unless otherwise specified

## Electrical Characteristics

Symbol	Characteristic	Test Conditions	Min	Typ	Max	Unit
$BV_{CES}$	Collector - Emitter Breakdown Voltage	$V_{GE} = 0V, I_C = 100\mu A$	600			V
$I_{CES}$	Zero Gate Voltage Collector Current	$V_{GE} = 0V$			100	$\mu A$
		$V_{CE} = 600V$			1000	
$V_{CE(on)}$	Collector Emitter on Voltage	$V_{GE} = 15V$		2.0	2.5	V
		$I_C = 90A$		2.2		
$V_{GE(th)}$	Gate Threshold Voltage	$V_{GE} = V_{CE}, I_C = 1mA$	3		5	V
$I_{GES}$	Gate - Emitter Leakage Current	$V_{GE} = 20V, V_{CE} = 0V$			$\pm 150$	nA

## Dynamic Characteristics

Symbol	Characteristic	Test Conditions	Min	Typ	Max	Unit	
$C_{ies}$	Input Capacitance	$V_{GE} = 0V$		4300		pF	
$C_{oes}$	Output Capacitance	$V_{CE} = 25V$		470			
$C_{res}$	Reverse Transfer Capacitance	$f = 1MHz$		400			
$Q_g$	Total gate Charge	$V_{GS} = 15V$		330		nC	
$Q_{ge}$	Gate - Emitter Charge	$V_{Bus} = 300V$		290			
$Q_{gc}$	Gate - Collector Charge	$I_C = 90A$		200			
$T_{d(on)}$	Turn-on Delay Time	Inductive Switching ( $25^\circ\text{C}$ ) $V_{GE} = 15V$ $V_{Bus} = 400V$ $I_C = 90A$ $R_G = 5\Omega$		26		ns	
$T_r$	Rise Time			25			
$T_{d(off)}$	Turn-off Delay Time			150			
$T_f$	Fall Time			30			
$E_{on}$	Turn-on Switching Energy ①			3.35			mJ
$E_{off}$	Turn-off Switching Energy ②			2.85			
$T_{d(on)}$	Turn-on Delay Time	Inductive Switching ( $125^\circ\text{C}$ ) $V_{GE} = 15V$ $V_{Bus} = 400V$ $I_C = 90A$ $R_G = 5\Omega$		26		ns	
$T_r$	Rise Time			25			
$T_{d(off)}$	Turn-off Delay Time			170			
$T_f$	Fall Time			40			
$E_{on}$	Turn-on Switching Energy ①			4.3			mJ
$E_{off}$	Turn-off Switching Energy ②			3.5			

①  $E_{on}$  includes diode reverse recovery

② In accordance with JEDEC standard JESD24-1

## Diode ratings and characteristics

Symbol	Characteristic	Test Conditions		Min	Typ	Max	Unit
V <sub>RRM</sub>	Maximum Peak Repetitive Reverse Voltage			600			V
I <sub>RM</sub>	Maximum Reverse Leakage Current	V <sub>R</sub> =600V	T <sub>j</sub> = 25°C			250	μA
			T <sub>j</sub> = 125°C			500	
I <sub>F(AV)</sub>	Maximum Average Forward Current	50% duty cycle	T <sub>c</sub> = 70°C		60		A
V <sub>F</sub>	Diode Forward Voltage	I <sub>F</sub> = 60A			1.6	1.8	V
		I <sub>F</sub> = 120A			1.9		
		I <sub>F</sub> = 60A	T <sub>j</sub> = 125°C		1.4		
t <sub>rr</sub>	Reverse Recovery Time	I <sub>F</sub> = 60A V <sub>R</sub> = 400V di/dt = 200A/μs	T <sub>j</sub> = 25°C		130		ns
			T <sub>j</sub> = 125°C		170		
Q <sub>rr</sub>	Reverse Recovery Charge	I <sub>F</sub> = 60A V <sub>R</sub> = 400V di/dt = 200A/μs	T <sub>j</sub> = 25°C		220		nC
			T <sub>j</sub> = 125°C		920		

## Thermal and package characteristics

Symbol	Characteristic			Min	Typ	Max	Unit
R <sub>thJC</sub>	Junction to Case	IGBT				0.3	°C/W
		Diode				0.9	
V <sub>ISOL</sub>	RMS Isolation Voltage, any terminal to case t=1 min, I <sub>isol</sub> <1mA, 50/60Hz			2500			V
T <sub>J</sub>	Operating junction temperature range			-40		150	°C
T <sub>STG</sub>	Storage Temperature Range			-40		125	
T <sub>C</sub>	Operating Case Temperature			-40		100	
Torque	Mounting torque	To heatsink	M6	3		5	N.m
Wt	Package Weight					250	g

## Package outline

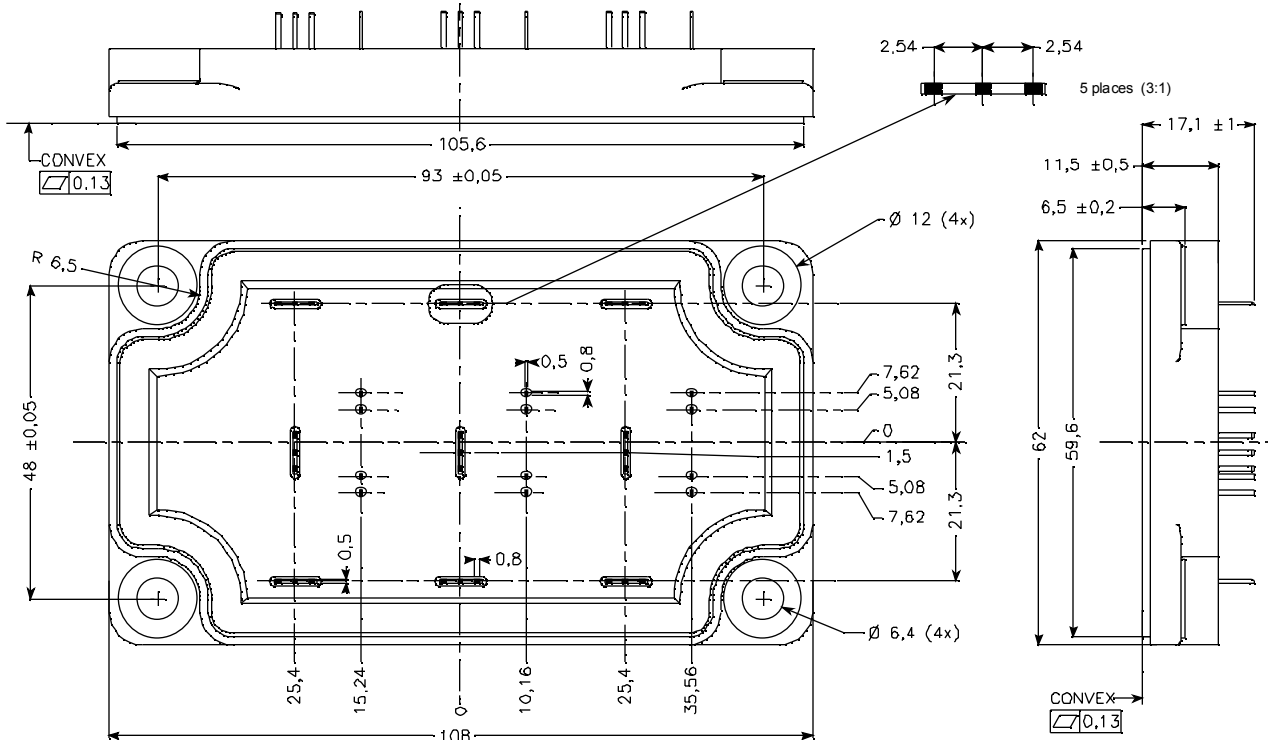

**Typical Performance Curve**

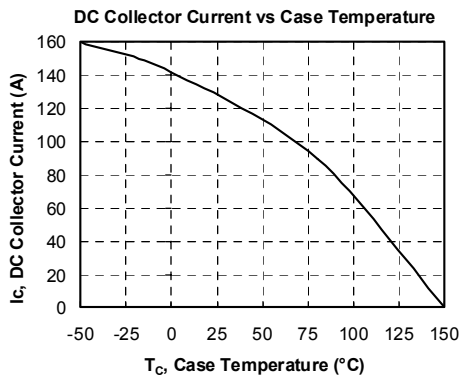
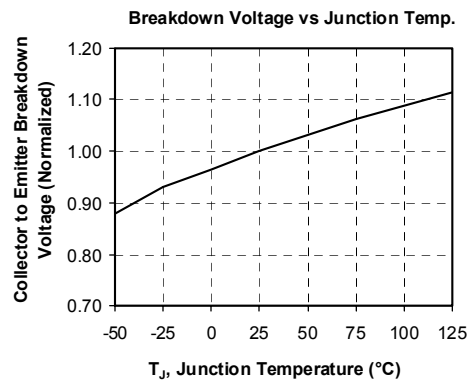
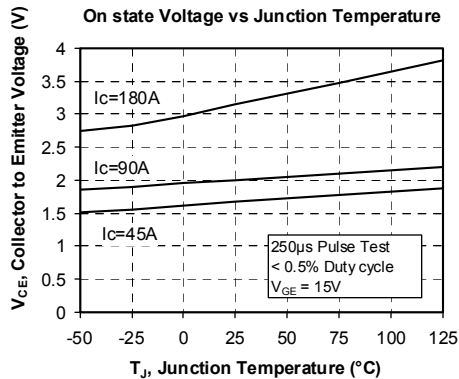
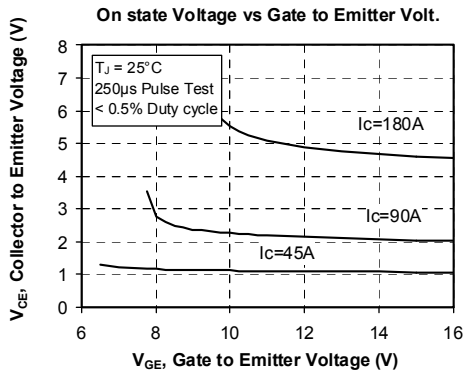
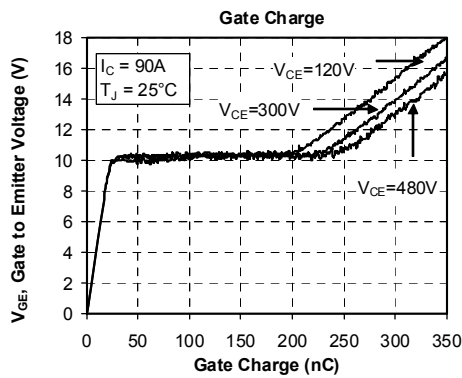
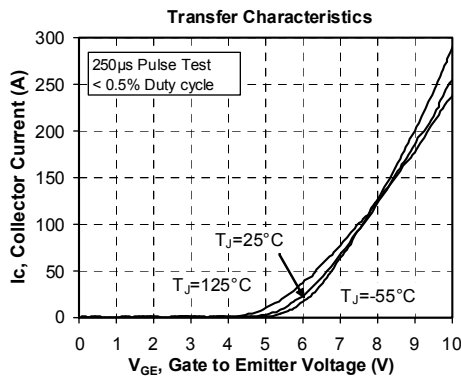
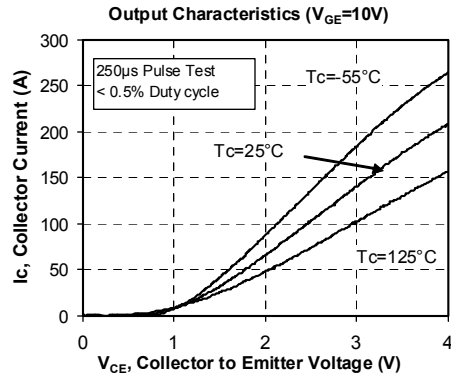
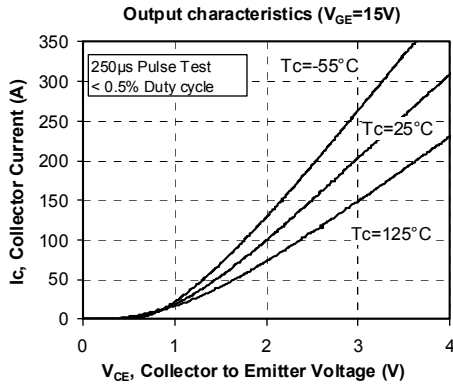

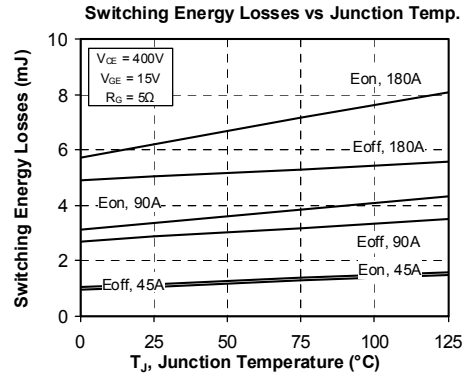
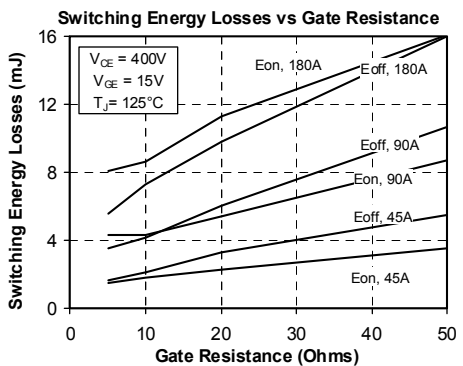
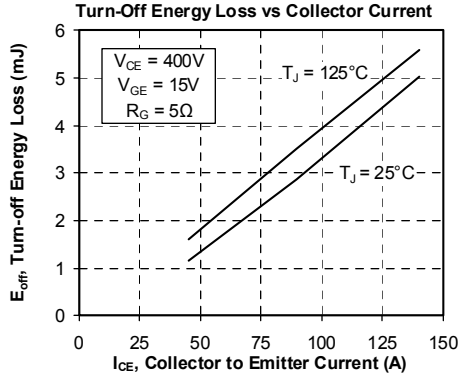
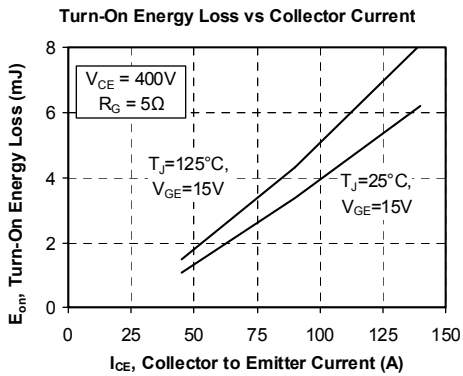
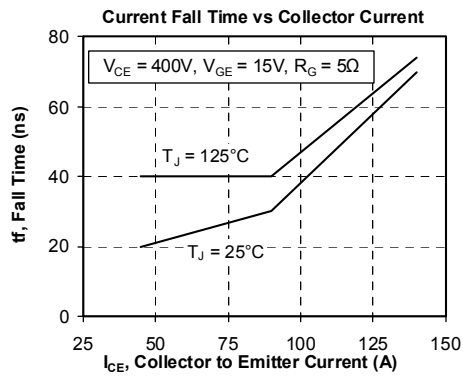
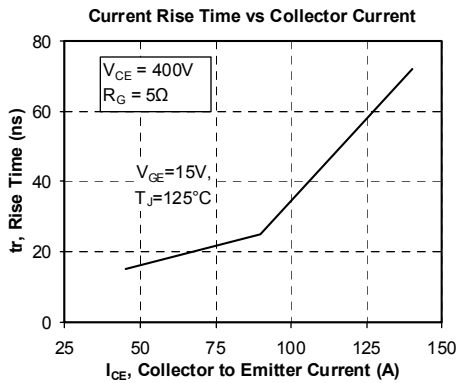
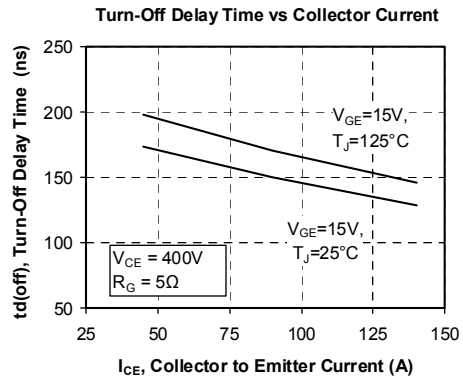
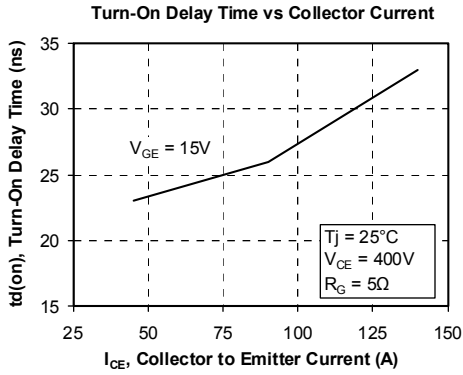

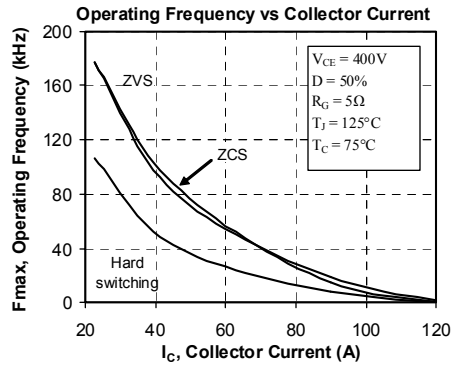
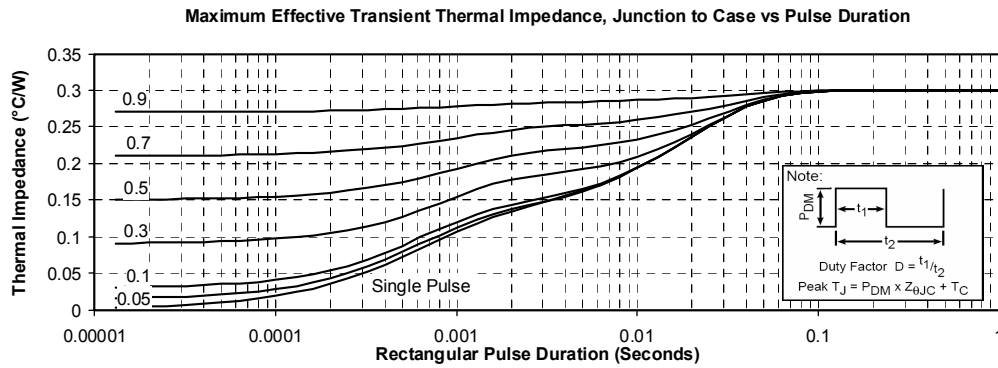
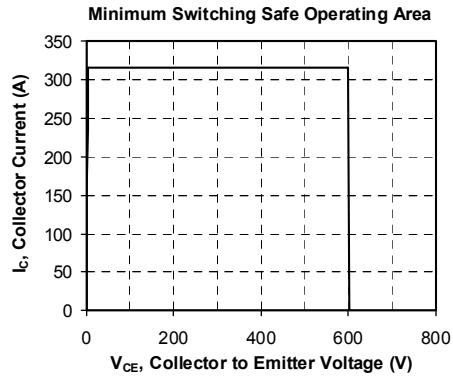
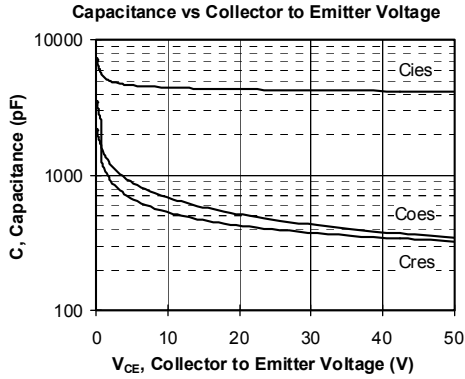

APT reserves the right to change, without notice, the specifications and information contained herein

APT's products are covered by one or more of U.S. patents 4,895,810 5,045,903 5,089,434 5,182,234 5,019,522 5,262,336 6,503,786 5,256,583 4,748,103 5,283,202 5,231,474 5,434,095 5,528,058 and foreign patents. U.S. and Foreign patents pending. All Rights Reserved.