



5V 1M×16 CMOS DRAM (fast-page mode)

Features

- Organization: 1,048,576 words × 16 bits
- High speed
 - 50/60 ns $\overline{\text{RAS}}$ access time
 - 20/25 ns fast page cycle time
 - 13/17 ns $\overline{\text{CAS}}$ access time
- Low power consumption
 - Active: 880 mW max (AS4C1M16E0-60)
 - Standby: 11 mW max, CMOS DQ
- Fast page mode
- 1024 refresh cycles, 16 ms refresh interval
 - $\overline{\text{RAS}}$ -only or $\overline{\text{CAS}}$ -before- $\overline{\text{RAS}}$ refresh
- Read-modify-write
- TTL-compatible, three-state DQ
- JEDEC standard package and pinout
 - 400 mil, 42-pin SOJ
 - 400 mil, 44/50-pin TSOP II
- 5V power supply
- Industrial and commercial temperature available

Pin arrangement

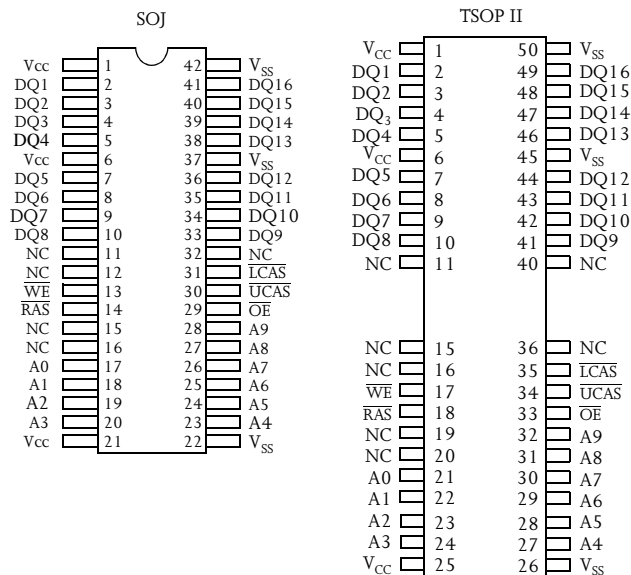

Pin designation

Pin(s)	Description
A0 to A9	Address inputs
$\overline{\text{RAS}}$	Row address strobe
DQ1 to DQ16	Input/output
$\overline{\text{OE}}$	Output enable
$\overline{\text{WE}}$	Write enable
$\overline{\text{UCAS}}$	Column address strobe, upper byte
$\overline{\text{LCAS}}$	Column address strobe, lower byte
V_{CC}	Power
V_{SS}	Ground

Selection guide

	Symbol	AS4C1M16F5-50	AS4C1M16F5-60	Unit
Maximum $\overline{\text{RAS}}$ access time	t_{RAC}	50	60	ns
Maximum column address access time	t_{AA}	25	30	ns
Maximum $\overline{\text{CAS}}$ access time	t_{CAC}	13	17	ns
Maximum output enable ($\overline{\text{OE}}$) access time	t_{OEA}	13	15	ns
Minimum read or write cycle time	t_{RC}	84	104	ns
Minimum fast page mode cycle time	t_{PC}	20	25	ns
Maximum operating current	I_{CC1}	170	160	mA
Maximum CMOS standby current	I_{CC5}	2.0	2.0	mA



Functional description

The AS4C1M16F5 is a high performance 16-megabit CMOS Dynamic Random Access Memory (DRAM) organized as 1,048,576 words \times 16 bits. The AS4C1M16F5 is fabricated using advanced CMOS technology and innovative design techniques resulting in high speed, extremely low power and wide operating margins at component and system levels. The Alliance 16Mb DRAM family is optimized for use as main memory in personal and portable PCs, workstations, and multimedia and router switch applications.

The AS4C1M16F5 features high speed page mode operation where read and write operations within a single row (or page) can be executed at very high speed (15 ns from $\overline{\text{XCAS}}$) by toggling column addresses within that row. Row and column addresses are alternately latched into input buffers using the falling edge of $\overline{\text{RAS}}$ and $\overline{\text{XCAS}}$ inputs respectively. Also, $\overline{\text{RAS}}$ is used to make the column address latch transparent, enabling application of column addresses prior to $\overline{\text{XCAS}}$ assertion. The AS4C1M16F5 provides dual $\overline{\text{UCAS}}$ and $\overline{\text{LCAS}}$ for independent byte control of read and write access.

Refresh on the 1024 address combinations of A0 to A9 must be performed every 16 ms using:

- $\overline{\text{RAS}}$ -only refresh: $\overline{\text{RAS}}$ is asserted while $\overline{\text{XCAS}}$ is held high. Each of the 1024 rows must be strobed. Outputs remain high impedance.
- Hidden refresh: $\overline{\text{XCAS}}$ is held low while $\overline{\text{RAS}}$ is toggled. Outputs remain low impedance with previous valid data.
- $\overline{\text{CAS}}$ -before- $\overline{\text{RAS}}$ refresh (CBR): At least one $\overline{\text{XCAS}}$ is asserted prior to $\overline{\text{RAS}}$. Refresh address is generated internally. Outputs are high-impedance ($\overline{\text{OE}}$ and $\overline{\text{WE}}$ are don't care).
- Normal read or write cycles refresh the row being accessed.

The AS4C1M16F5 is available in the standard 42-pin plastic SOJ and the 44/50-pin TSOP II packages, respectively. It operates with a single power supply of $5V \pm 0.5V$. The device provides TTL compatible inputs and outputs.

Logic block diagram

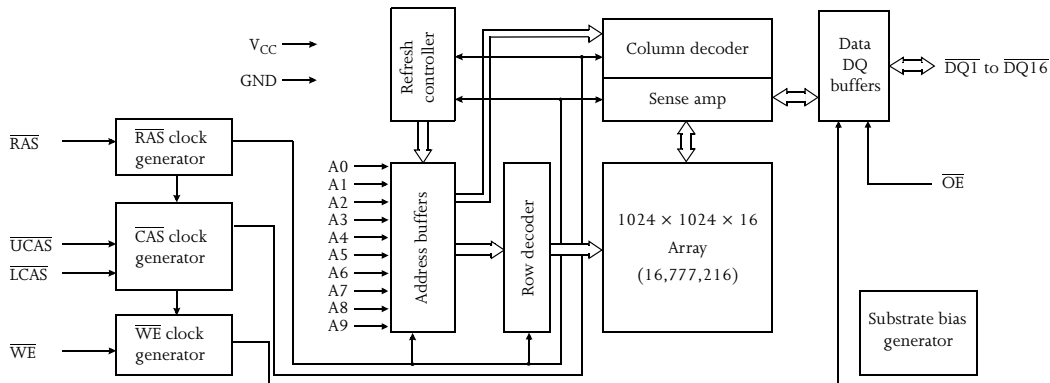

Recommended operating conditions

Parameter		Symbol	Min	Nominal	Max	Unit
Supply voltage	AS4C1M16F5	V_{CC}	4.5	5.0	5.5	V
		GND	0.0	0.0	0.0	V
Input voltage	AS4C1M16F5	V_{IH}	2.4	—	V_{CC}	V
		V_{IL}	-0.5 [†]	—	0.8	V
Ambient operating temperature	Commercial	T_A	0	—	70	°C
	Industrial		-40	—	85	

[†] V_{IL} min -3.0V for pulse widths less than 5 ns.

Recommended operating conditions apply throughout this document unless otherwise specified.



Absolute maximum ratings

Parameter	Symbol	Min	Max	Unit
Input voltage	V_{in}	-1.0	+7.0	V
Input voltage (DQs)	V_{DQ}	-1.0	$V_{CC} + 0.5$	V
Power supply voltage	V_{CC}	-1.0	+7.0	V
Storage temperature (plastic)	T_{STG}	-55	+150	°C
Soldering temperature × time	T_{SOLDER}	–	260 × 10	°C × sec
Power dissipation	P_D	–	1	W
Short circuit output current	I_{out}	–	50	mA

DC electrical characteristics

Parameter	Symbol	Test conditions	-50		-60		Unit	Notes
			Min	Max	Min	Max		
Input leakage current	I_{IL}	$0V \leq V_{in} \leq +5.5V$, Pins not under test = 0V	-5	+5	-5	+5	μA	
Output leakage current	I_{OL}	D_{OUT} disabled, $0V \leq V_{out} \leq +5.5V$	-5	+5	-5	+5	μA	
Operating power supply current	I_{CC1}	\overline{RAS} , \overline{UCAS} , \overline{LCAS} , Address cycling; $t_{RC} = \text{min}$	–	170	–	160	mA	1,2
TTL standby power supply current	I_{CC2}	$\overline{RAS} = \overline{UCAS} = \overline{LCAS} \geq V_{IH}$	–	2.5	–	2.5	mA	
Average power supply current, \overline{RAS} refresh mode or CBR	I_{CC3}	\overline{RAS} cycling, $\overline{UCAS} = \overline{LCAS} \geq V_{IH}$, $t_{RC} = \text{min of } \overline{RAS} \text{ low after } \overline{XCAS} \text{ low.}$	–	170	–	160	mA	1
Fast page mode average power supply current	I_{CC4}	$\overline{RAS} = V_{IL}$, \overline{UCAS} or \overline{LCAS} , address cycling: $t_{PC} = \text{min}$	–	120	–	110	mA	1, 2
CMOS standby power supply current	I_{CC5}	$\overline{RAS} = \overline{UCAS} = \overline{LCAS} = V_{CC} - 0.2V$	–	2.0	–	2.0	mA	
Output voltage	V_{OH}	$I_{OUT} = -5.0 \text{ mA}$	2.4	–	2.4	–	V	
	V_{OL}	$I_{OUT} = 4.2 \text{ mA}$	–	0.4	–	0.4	V	
\overline{CAS} before \overline{RAS} refresh current	I_{CC6}	\overline{RAS} , \overline{UCAS} or \overline{LCAS} cycling, $t_{RC} = \text{min}$	–	170	–	160	mA	



AC parameters common to all waveforms

Symbol	Parameter	-50		-60		Unit	Notes
		Min	Max	Min	Max		
t_{RC}	Random read or write cycle time	84	–	104	–	ns	
t_{RP}	\overline{RAS} precharge time	30	–	40	–	ns	
t_{RAS}	\overline{RAS} pulse width	50	10K	60	10K	ns	
t_{CAS}	\overline{CAS} pulse width	8	10K	10	10K	ns	
t_{RCD}	\overline{RAS} to \overline{CAS} delay time	15	35	15	43	ns	6
t_{RAD}	\overline{RAS} to column address delay time	12	25	12	30	ns	7
t_{RSH}	\overline{CAS} to \overline{RAS} hold time	10	–	10	–	ns	
t_{CSH}	\overline{RAS} to \overline{CAS} hold time	40	–	50	–	ns	
t_{CRP}	\overline{CAS} to \overline{RAS} precharge time	5	–	5	–	ns	
t_{ASR}	Row address setup time	0	–	0	–	ns	
t_{RAH}	Row address hold time	8	–	10	–	ns	
t_T	Transition time (rise and fall)	1	50	1	50	ns	4,5
t_{REF}	Refresh period	–	16	–	16	ms	3
t_{CP}	CAS precharge time	8	–	10	–	ns	
t_{RAL}	Column address to \overline{RAS} lead time	25	–	30	–	ns	
t_{ASC}	Column address setup time	0	–	0	–	ns	
t_{CAH}	Column address hold time	8	–	10	–	ns	

Read cycle

Symbol	Parameter	-50		-60		Unit	Notes
		Min	Max	Min	Max		
t_{RAC}	Access time from \overline{RAS}	–	50	–	60	ns	6
t_{CAC}	Access time from \overline{CAS}	–	13	–	17	ns	6,13
t_{AA}	Access time from address	–	25	–	30	ns	7,13
t_{RCS}	Read command setup time	0	–	0	–	ns	
t_{RCH}	Read command hold time to \overline{CAS}	0	–	0	–	ns	9
t_{RRH}	Read command hold time to \overline{RAS}	0	–	0	–	ns	9



Write cycle

Symbol	Parameter	-50		-60		Unit	Notes
		Min	Max	Min	Max		
t_{WCS}	Write command setup time	0	–	0	–	ns	11
t_{WCH}	Write command hold time	10	–	10	–	ns	11
t_{WP}	Write command pulse width	10	–	10	–	ns	
t_{RWL}	Write command to \overline{RAS} lead time	10	–	10	–	ns	
t_{CWL}	Write command to \overline{CAS} lead time	8	–	10	–	ns	
t_{DS}	Data-in setup time	0	–	0	–	ns	12
t_{DH}	Data-in hold time	8	–	10	–	ns	12

Read-modify-write cycle

Symbol	Parameter	-50		-60		Unit	Notes
		Min	Max	Min	Max		
t_{RWC}	Read-write cycle time	113	–	135	–	ns	
t_{RWD}	\overline{RAS} to \overline{WE} delay time	67	–	77	–	ns	11
t_{CWD}	\overline{CAS} to \overline{WE} delay time	32	–	35	–	ns	11
t_{AWD}	Column address to \overline{WE} delay time	42	–	47	–	ns	11

Refresh cycle

Symbol	Parameter	-50		-60		Unit	Notes
		Min	Max	Min	Max		
t_{CSR}	\overline{CAS} setup time (\overline{CAS} -before- \overline{RAS})	5	–	5	–	ns	3
t_{CHR}	\overline{CAS} hold time (\overline{CAS} -before- \overline{RAS})	8	–	10	–	ns	3
t_{RPC}	\overline{RAS} precharge to \overline{CAS} hold time	0	–	0	–	ns	
t_{CPT}	\overline{CAS} precharge time (CBR counter test)	10	–	10	–	ns	



Fast page mode cycle

Symbol	Parameter	-50		-60		Unit	Notes
		Min	Max	Min	Max		
t _{CPA}	Access time from $\overline{\text{CAS}}$ precharge	–	28	–	35	ns	13
t _{RASP}	$\overline{\text{RAS}}$ pulse width	50	100K	60	100K	ns	
t _{PC}	Read-write cycle time	30	–	35	–	ns	
t _{CP}	$\overline{\text{CAS}}$ precharge time (fast page)	10	–	10	–	ns	
t _{PCM}	Fast page mode RMW cycle	80	–	85	–	ns	
t _{CRW}	Page mode $\overline{\text{CAS}}$ pulse width (RMW)	54	–	60	–	ns	

Output enable

Symbol	Parameter	-50		-60		Unit	Notes
		Min	Max	Min	Max		
t _{CLZ}	$\overline{\text{CAS}}$ to output in Low Z	0	–	0	–	ns	8
t _{ROH}	$\overline{\text{RAS}}$ hold time referenced to $\overline{\text{OE}}$	8	–	10	–	ns	
t _{OEa}	$\overline{\text{OE}}$ access time	–	13	–	15	ns	
t _{OED}	$\overline{\text{OE}}$ to data delay	13	–	15	–	ns	
t _{OEZ}	Output buffer turnoff delay from $\overline{\text{OE}}$	0	13	0	15	ns	8
t _{OEh}	$\overline{\text{OE}}$ command hold time	10	–	10	–	ns	
t _{OLZ}	$\overline{\text{OE}}$ to output in Low Z	0	–	0	–	ns	
t _{OFF}	Output buffer turn-off time	0	13	0	15	ns	8,10



Notes

- I_{CC1} , I_{CC3} , and I_{CC4} are dependent on frequency.
- I_{CC1} and I_{CC4} depend on output loading. Specified values are obtained with the output open.
- An initial pause of 200 μ s is required after power-up followed by any 8 $\overline{\text{RAS}}$ cycles before proper device operation is achieved. In the case of an internal refresh counter, a minimum of 8 $\overline{\text{CAS}}$ -before- $\overline{\text{RAS}}$ initialization cycles instead of 8 $\overline{\text{RAS}}$ cycles are required. 8 initialization cycles are required after extended periods of bias without clocks (greater than 8 ms).
- AC Characteristics assume $t_T = 2$ ns. All AC parameters are measured with a load equivalent to two TTL loads and 100 pF, $V_{IL}(\text{min}) \geq \text{GND}$ and $V_{IH}(\text{max}) \leq V_{CC}$.
- $V_{IH}(\text{min})$ and $V_{IL}(\text{max})$ are reference levels for measuring timing of input signals. Transition times are measured between V_{IH} and V_{IL} .
- Operation within the $t_{\text{RCD}}(\text{max})$ limit insures that $t_{\text{RAC}}(\text{max})$ can be met. $t_{\text{RCD}}(\text{max})$ is specified as a reference point only. If t_{RCD} is greater than the specified $t_{\text{RCD}}(\text{max})$ limit, then access time is controlled exclusively by t_{CAC} .
- Operation within the $t_{\text{RAD}}(\text{max})$ limit insures that $t_{\text{RAC}}(\text{max})$ can be met. $t_{\text{RAD}}(\text{max})$ is specified as a reference point only. If t_{RAD} is greater than the specified $t_{\text{RAD}}(\text{max})$ limit, then access time is controlled exclusively by t_{AA} .
- Assumes three state test load (5 pF and a 380 Ω Thevenin equivalent).
- Either t_{RCH} or t_{RRH} must be satisfied for a read cycle.
- $t_{\text{OFF}}(\text{max})$ defines the time at which the output achieves the open circuit condition; it is not referenced to output voltage levels. t_{OFF} is referenced from rising edge of $\overline{\text{RAS}}$ or $\overline{\text{CAS}}$, whichever occurs last.
- t_{WCS} , t_{WCH} , t_{RWD} , t_{CWD} and t_{AWD} are not restrictive operating parameters. They are included in the datasheet as electrical characteristics only. If $t_{\text{WS}} \geq t_{\text{WS}}(\text{min})$ and $t_{\text{WH}} \geq t_{\text{WH}}(\text{min})$, the cycle is an early write cycle and data out pins will remain open circuit, high impedance, throughout the cycle. If $t_{\text{RWD}} \geq t_{\text{RWD}}(\text{min})$, $t_{\text{CWD}} \geq t_{\text{CWD}}(\text{min})$ and $t_{\text{AWD}} \geq t_{\text{AWD}}(\text{min})$, the cycle is a read-write cycle and the data out will contain data read from the selected cell. If neither of the above conditions is satisfied, the condition of the data out at access time is indeterminate.
- These parameters are referenced to $\overline{\text{CAS}}$ leading edge in early write cycles and to $\overline{\text{WE}}$ leading edge in read-write cycles.
- Access time is determined by the longest of t_{CAA} or t_{CAC} or t_{CPA}
- $t_{\text{ASC}} \geq t_{\text{CP}}$ to achieve $t_{\text{PC}}(\text{min})$ and $t_{\text{CPA}}(\text{max})$ values.
- These parameters are sampled and not 100% tested.
- These characteristics apply to AS4C1M16F5 5V devices.

AC test conditions

- Access times are measured with output reference levels of $V_{\text{OH}} = 2.4\text{V}$ and $V_{\text{OL}} = 0.4\text{V}$, $V_{\text{IH}} = 2.4\text{V}$ and $V_{\text{IL}} = 0.8\text{V}$
- Input rise and fall times: 2 ns

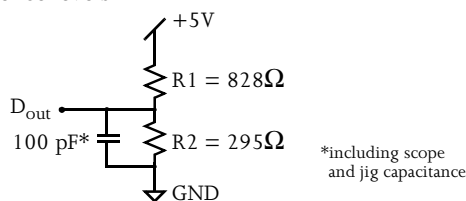

Figure A: Equivalent output load

Key to switching waveforms



Rising input



Falling input



Undefined output/don't care



Read waveform

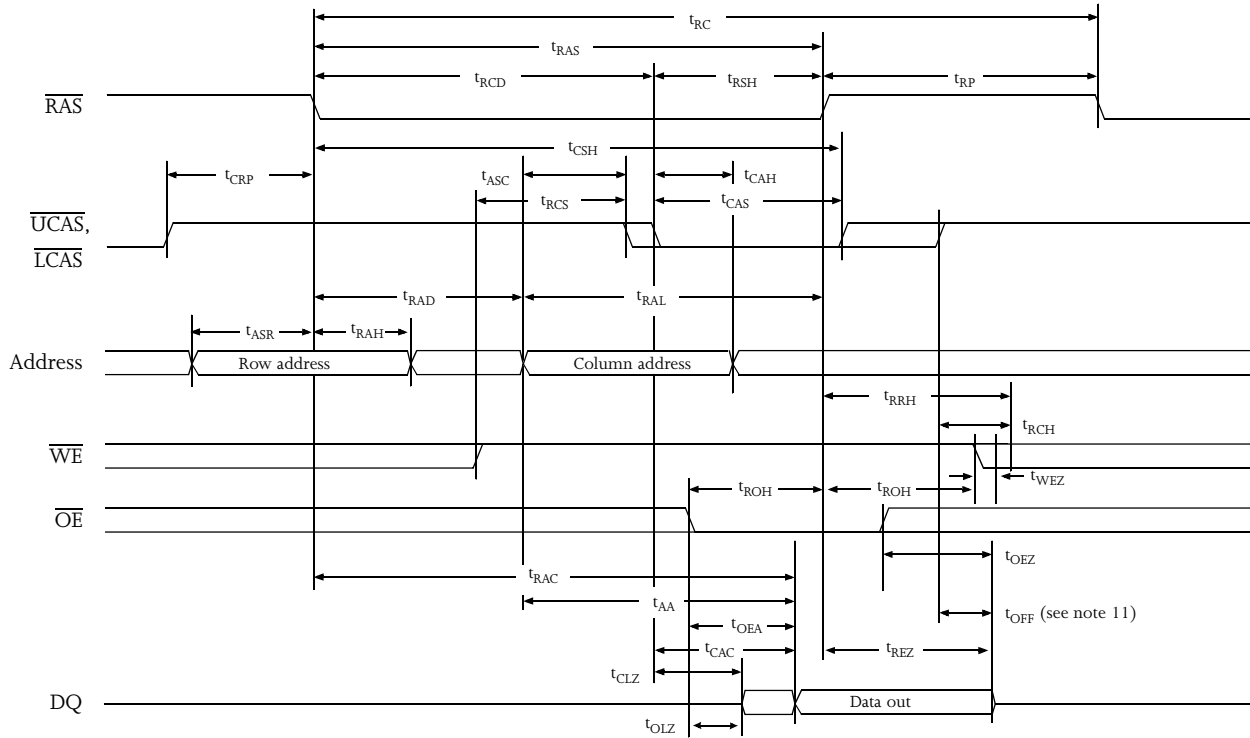

Upper byte read waveform

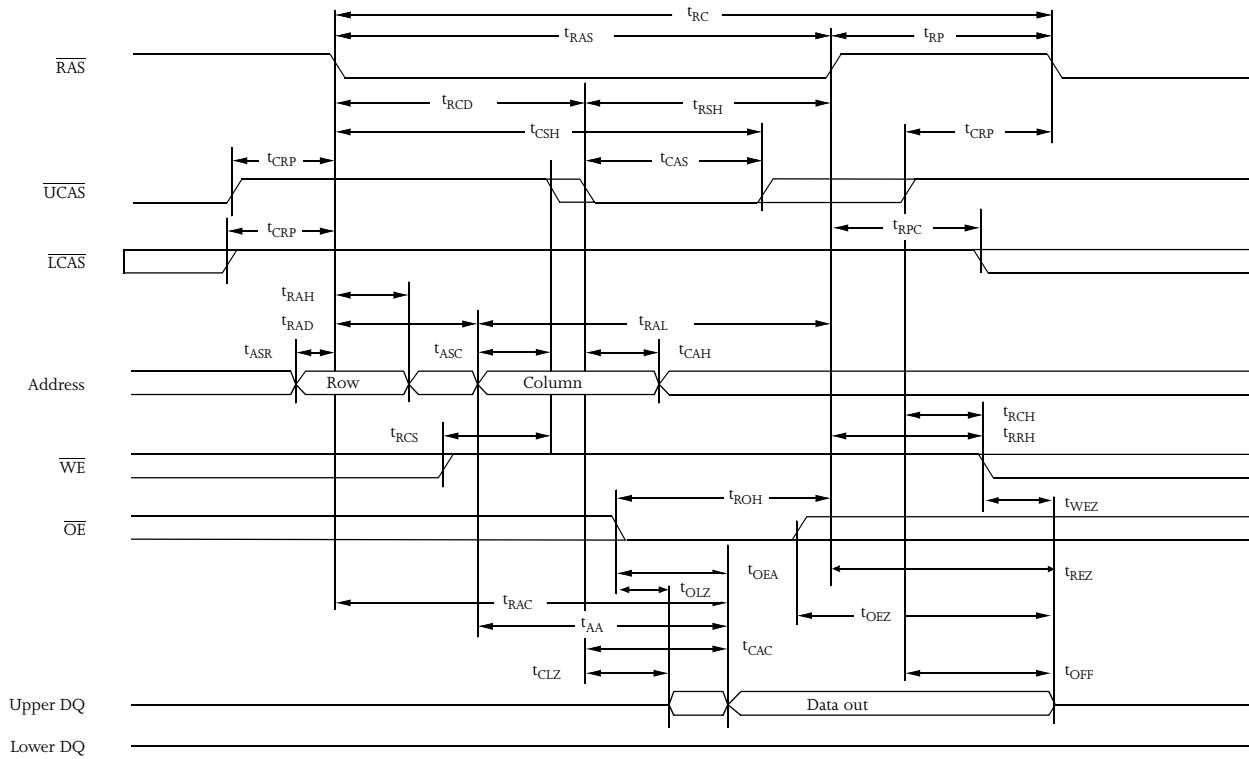



Lower byte read waveform

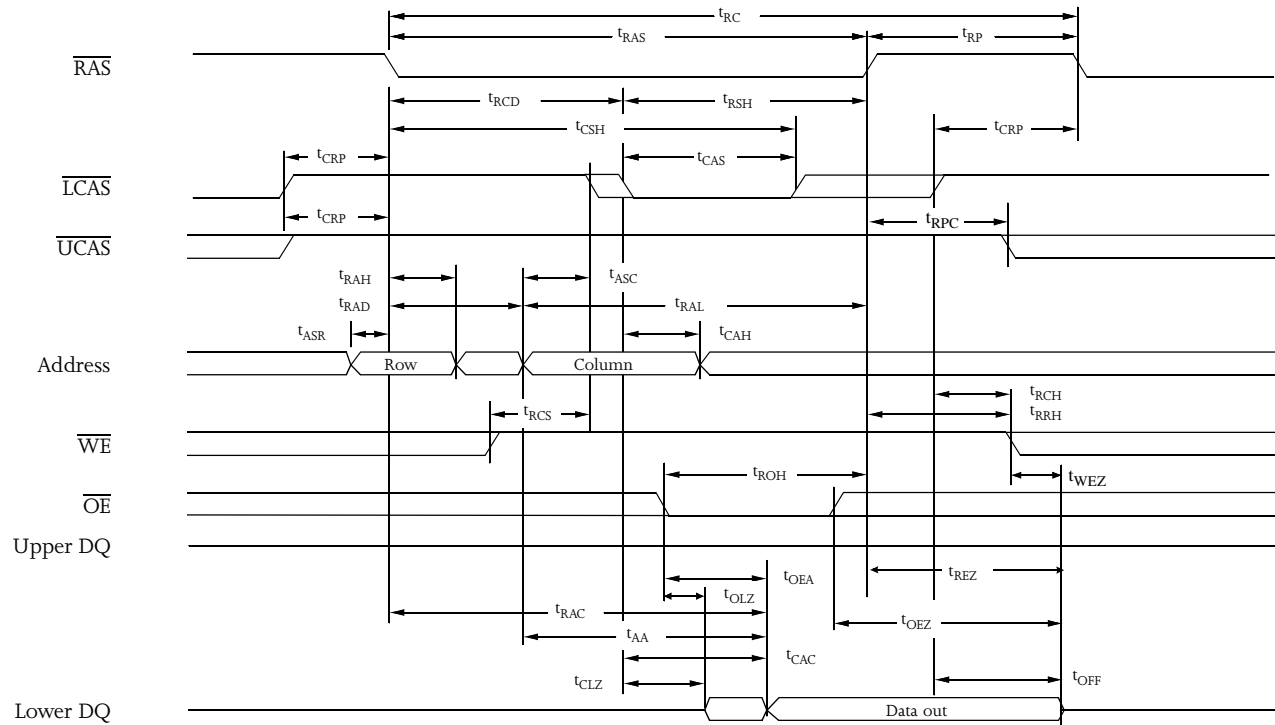

Early write waveform

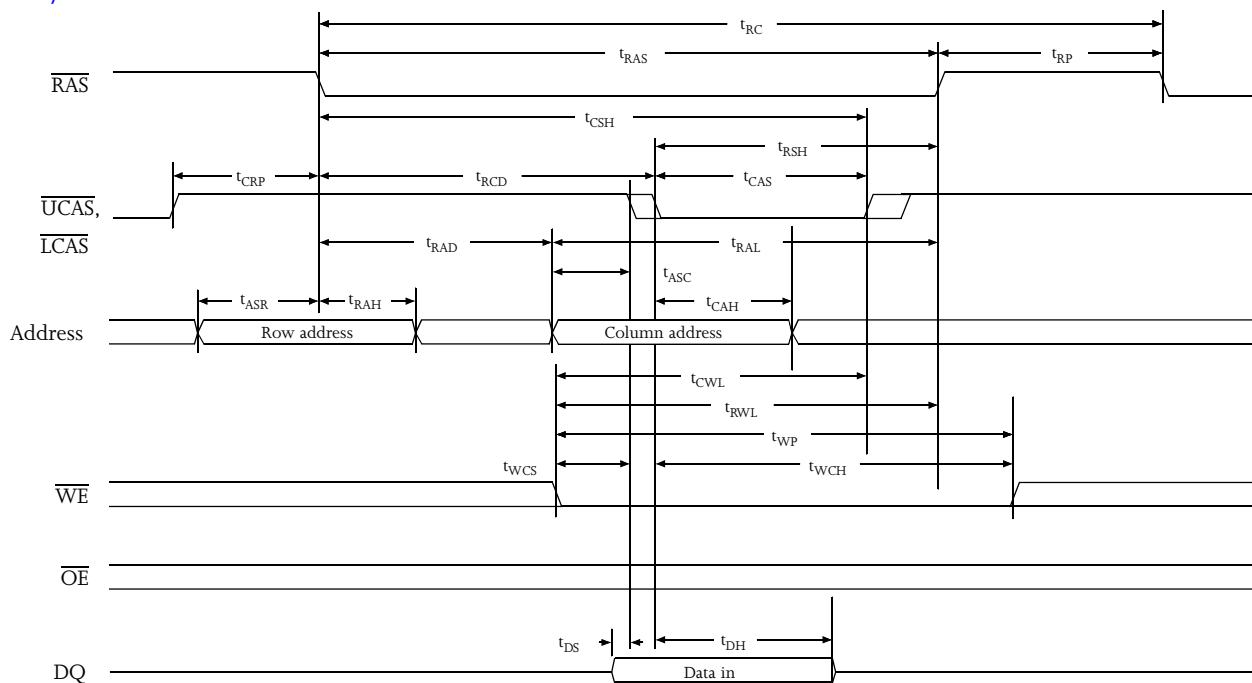



Upper byte early write waveform

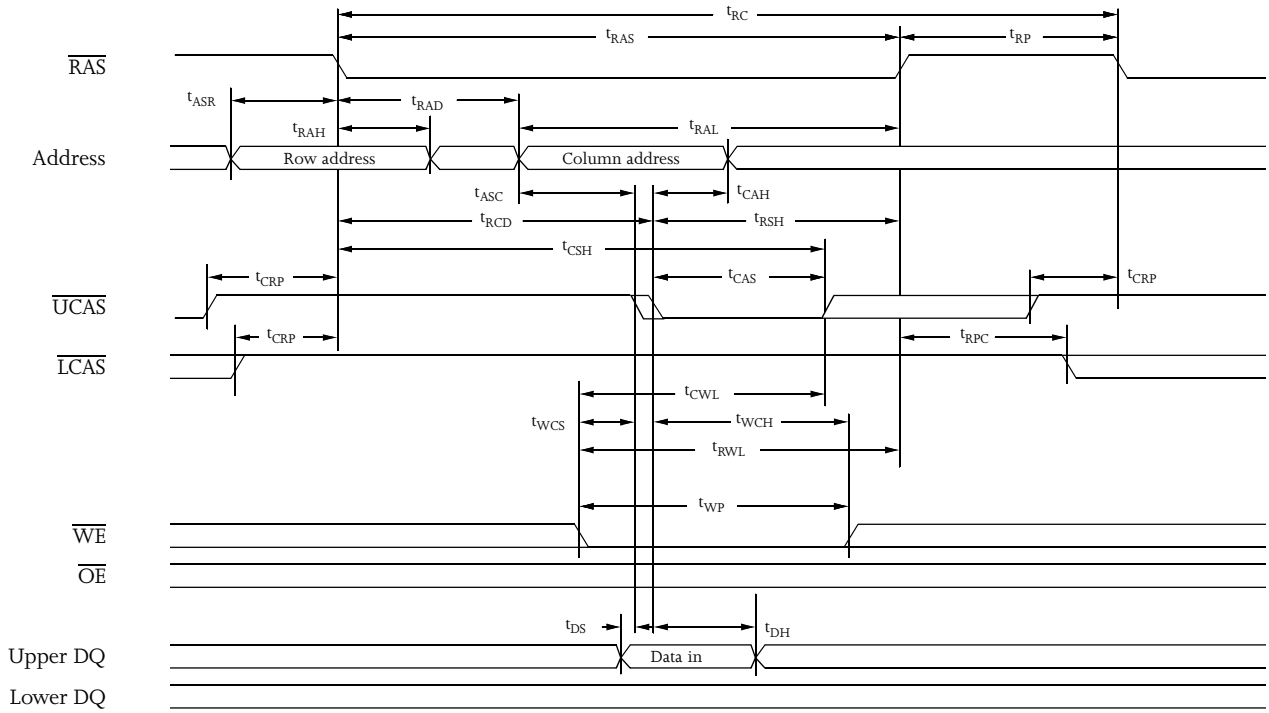

Lower byte early write waveform

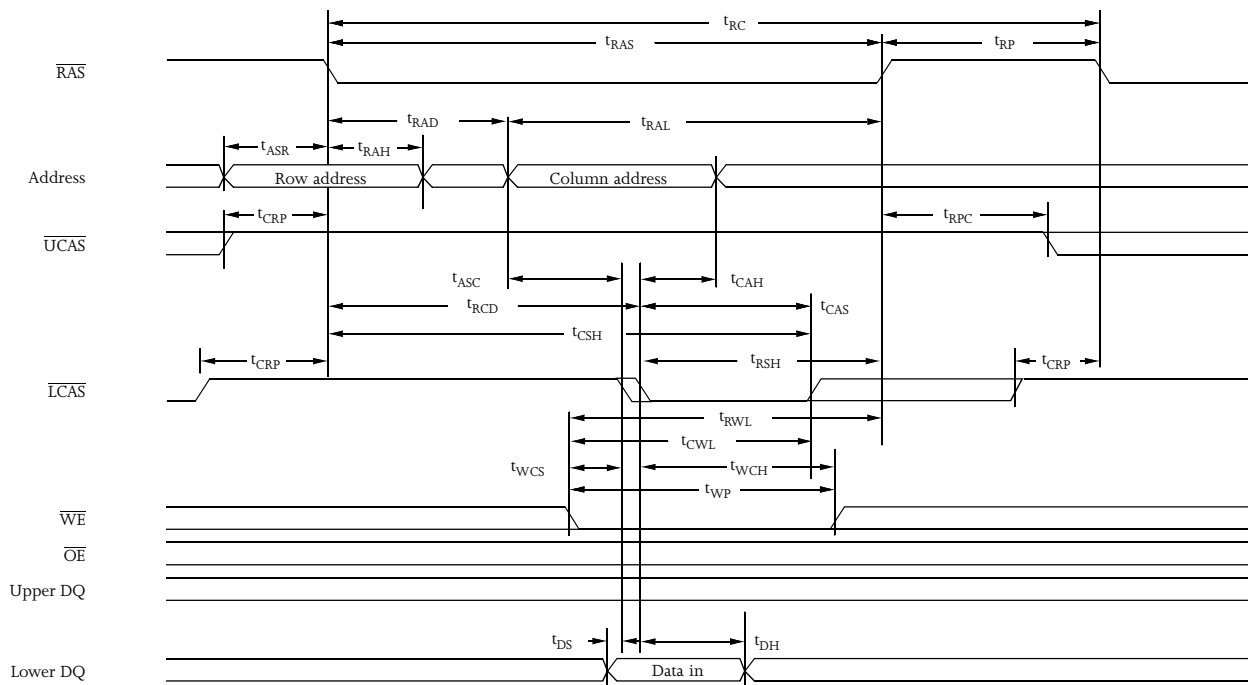



Write waveform

\overline{OE} controlled

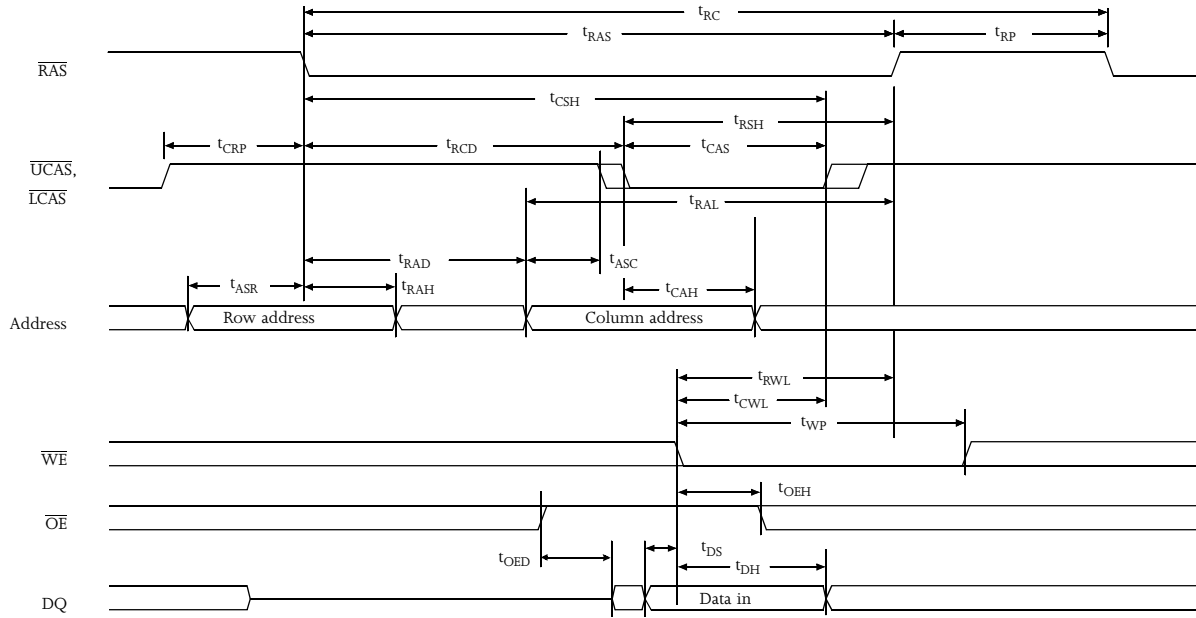

Upper byte write waveform

\overline{OE} controlled

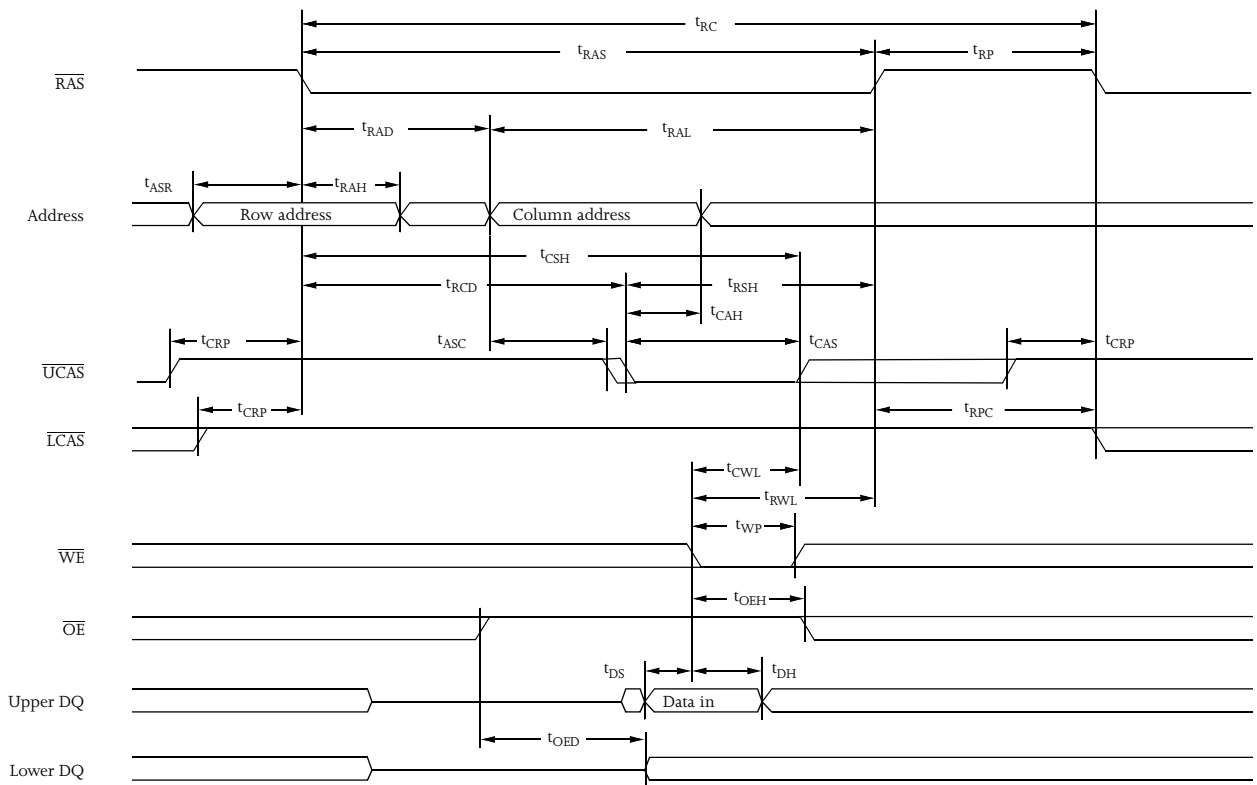



Lower byte write waveform

\overline{OE} controlled

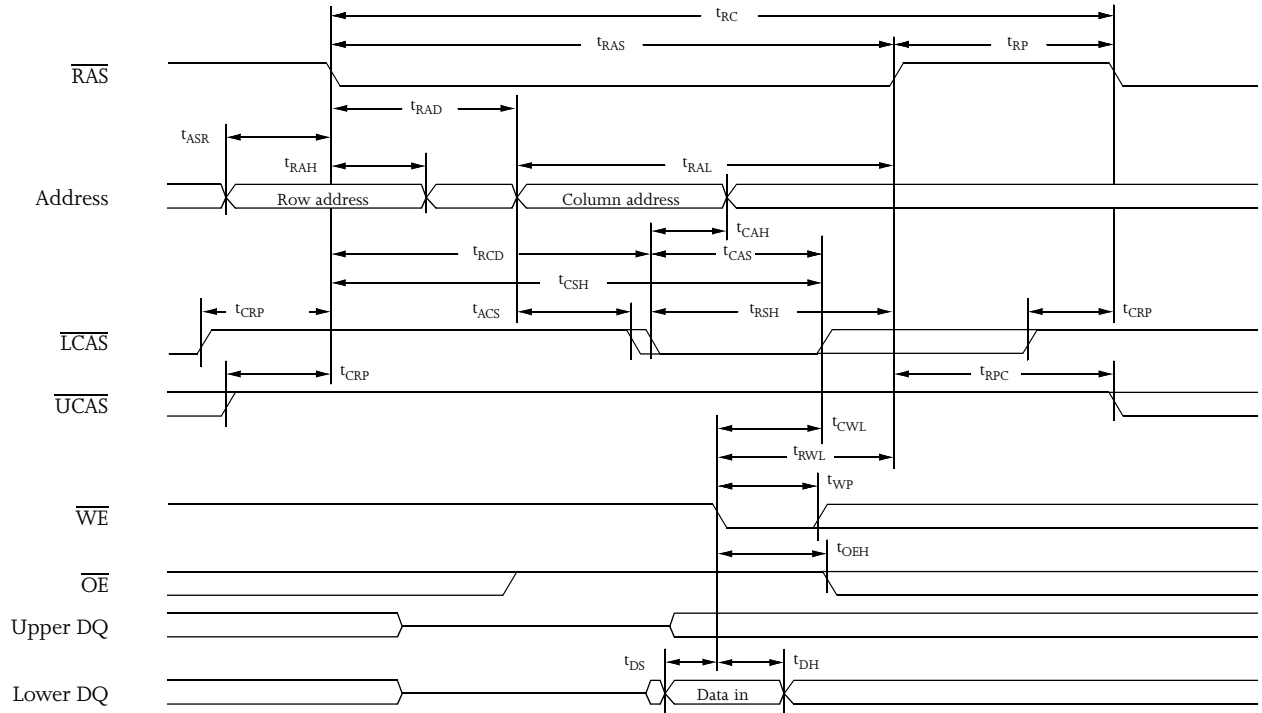

Read-modify-write waveform

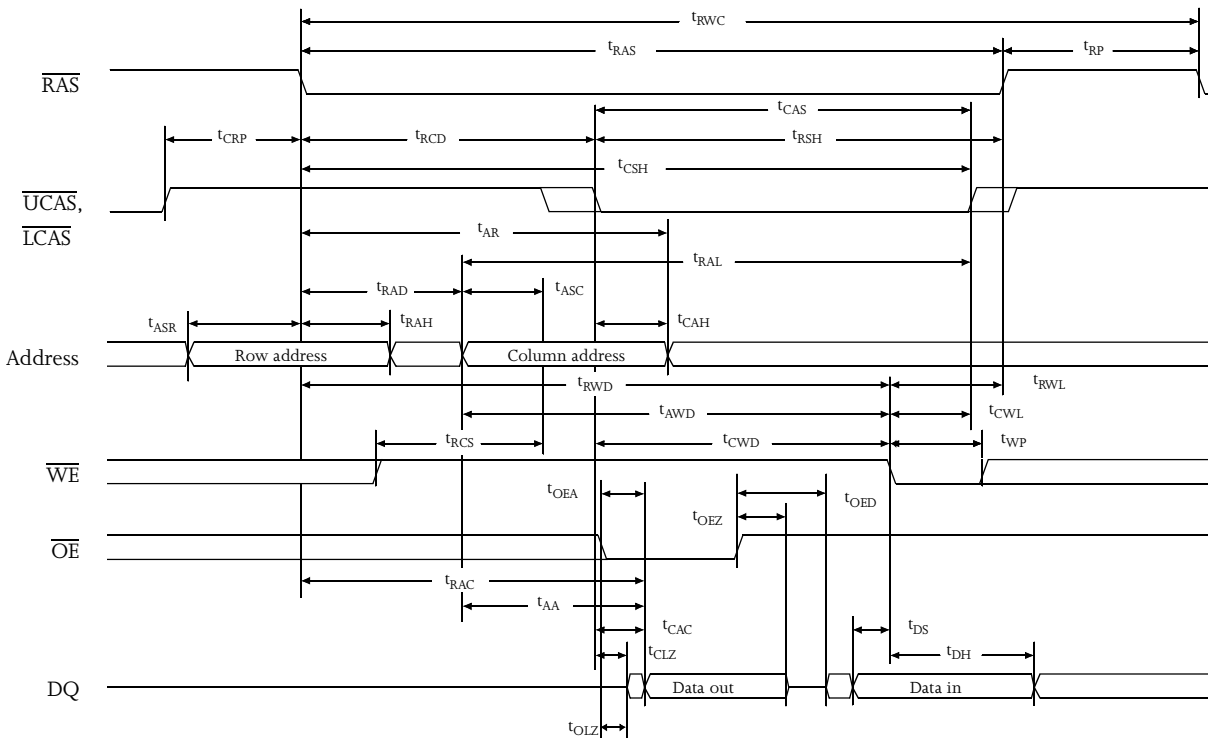



Upper byte read-modify-write waveform

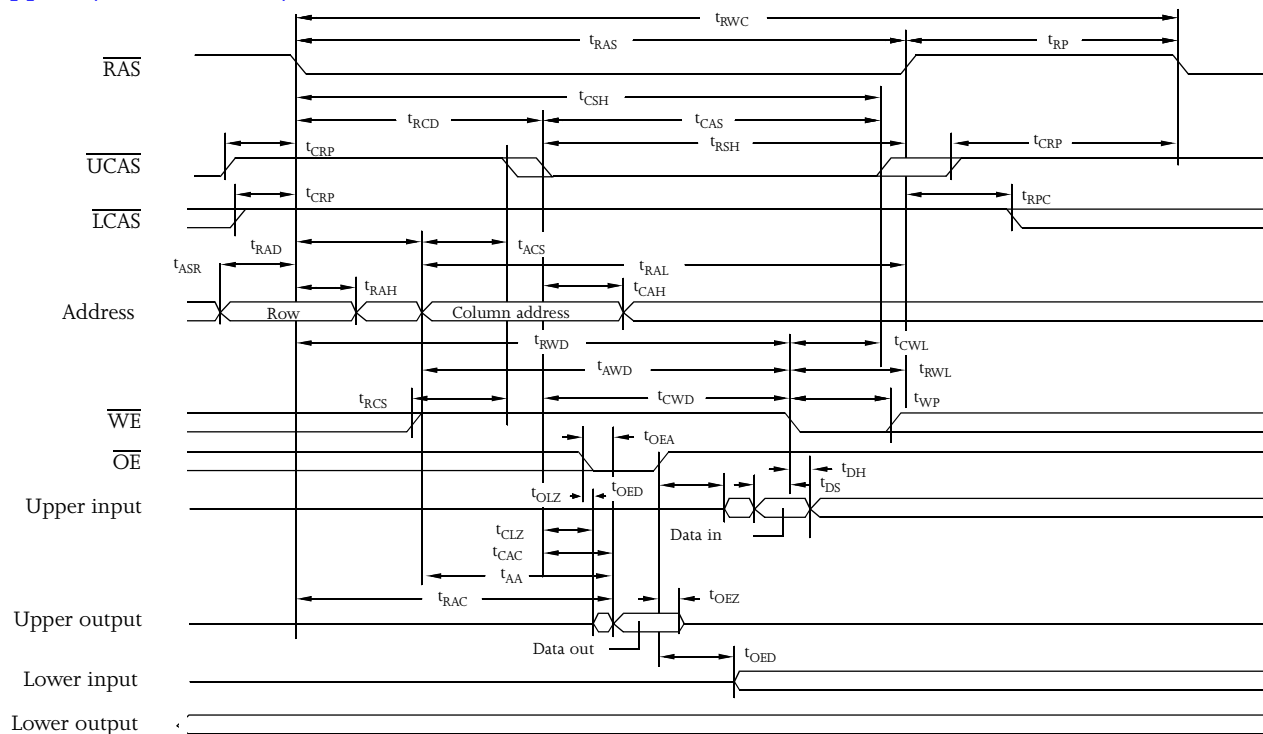

Lower byte read-modify-write waveform

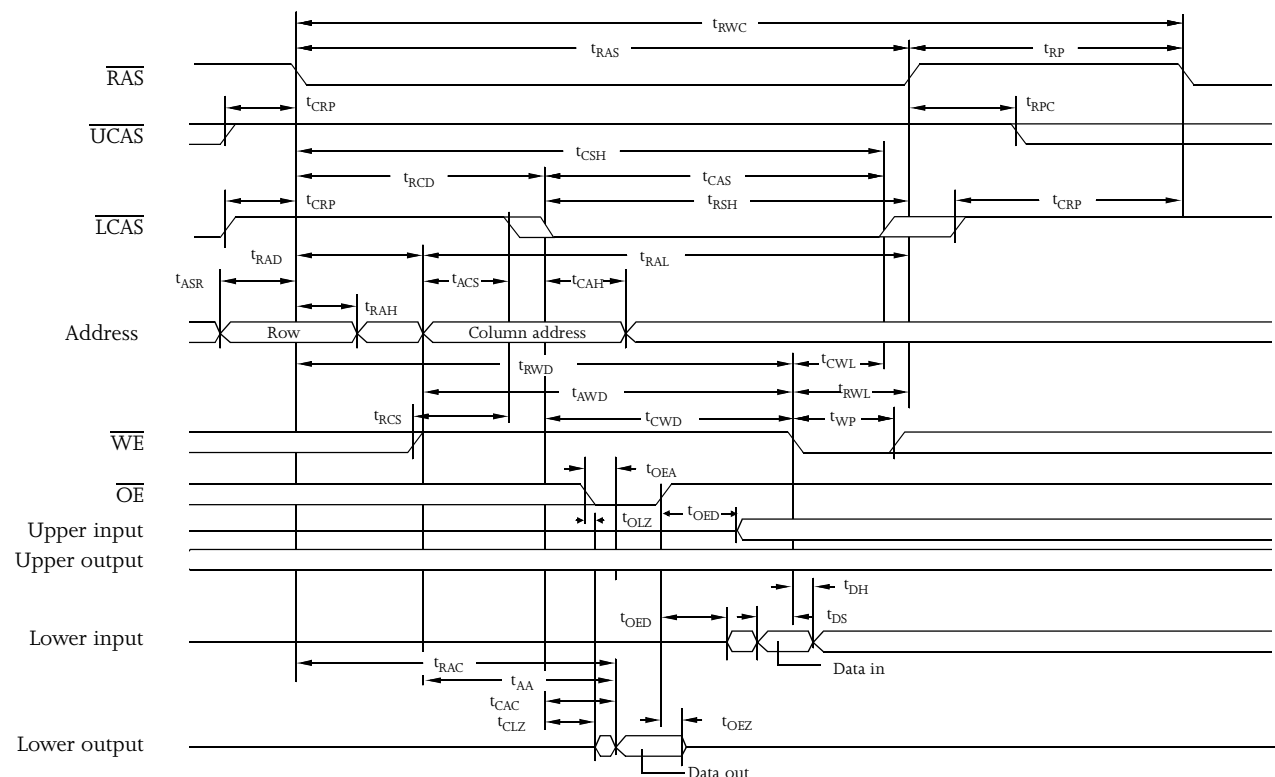



Fast page mode read waveform

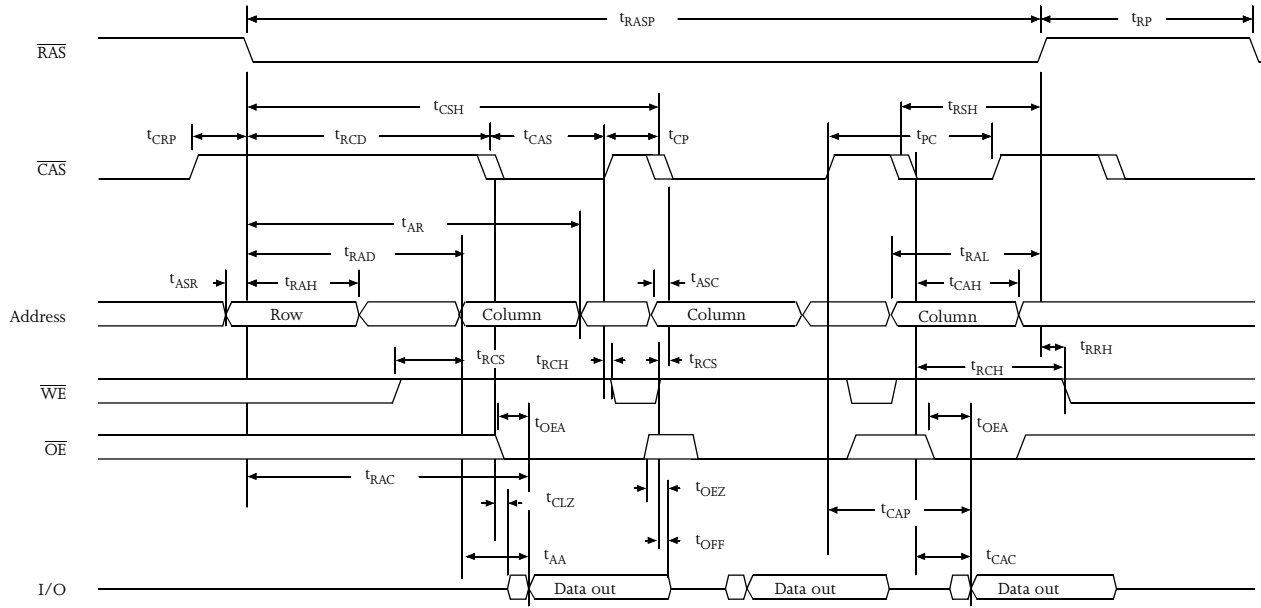

Fast page mode byte write waveform

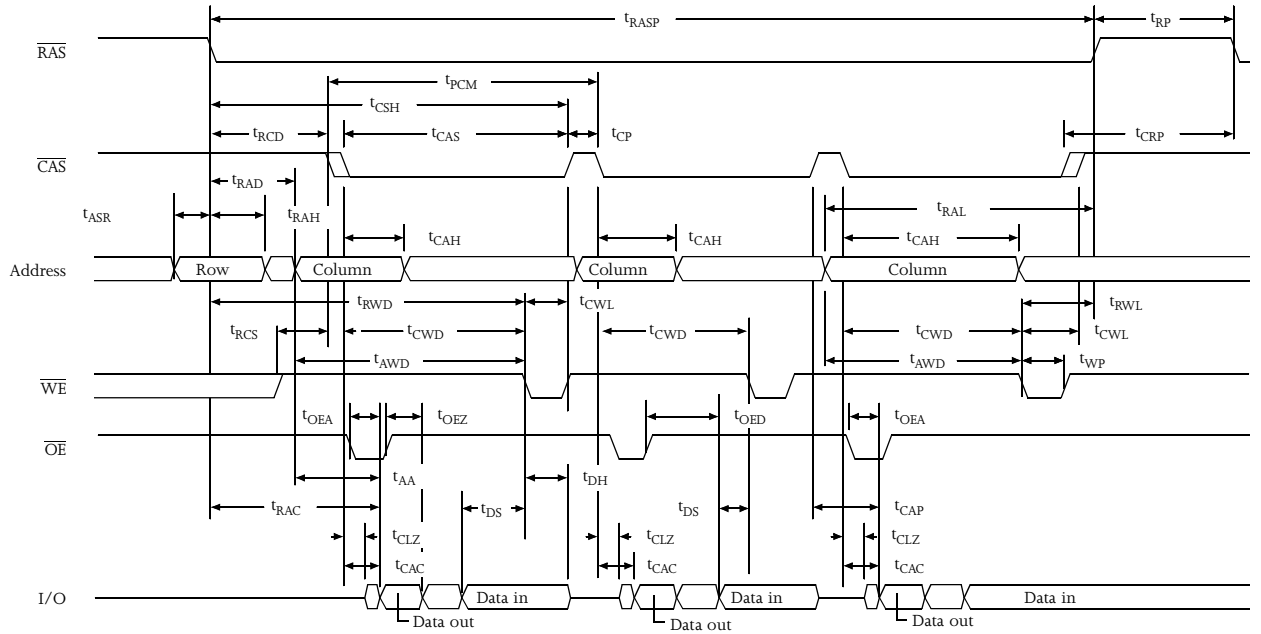



Fast page mode early write waveform

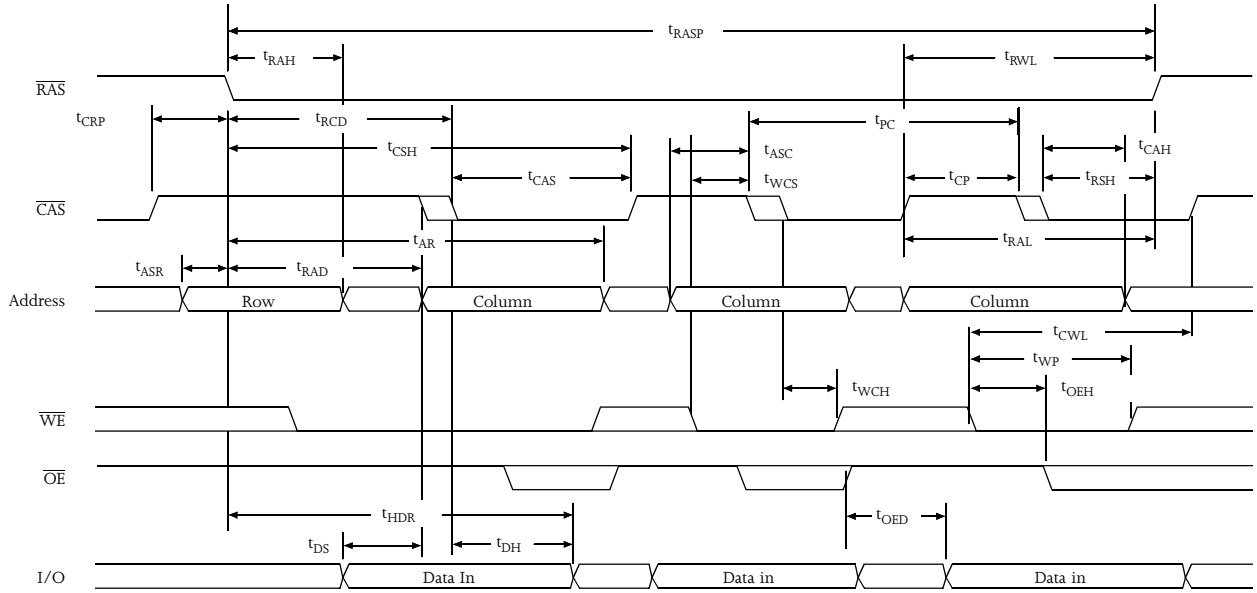

CAS before RAS refresh waveform

$\overline{WE} = V_{IH}$

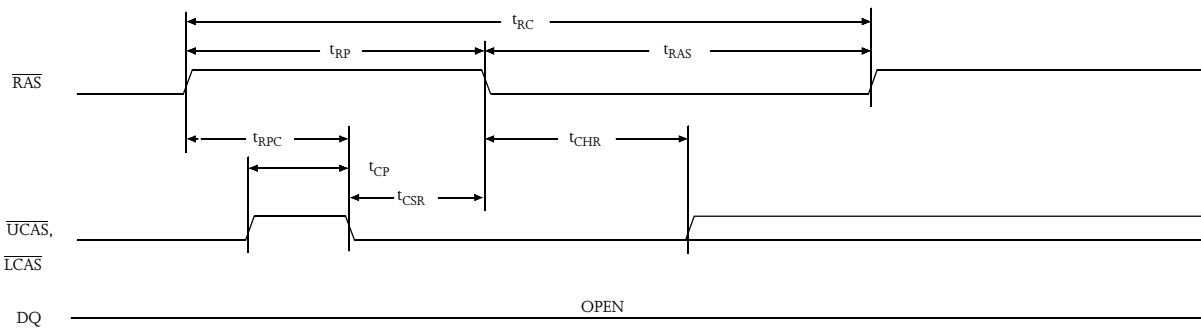

RAS only refresh waveform

$\overline{WE} = \overline{OE} = V_{IH} \text{ or } V_{IL}$

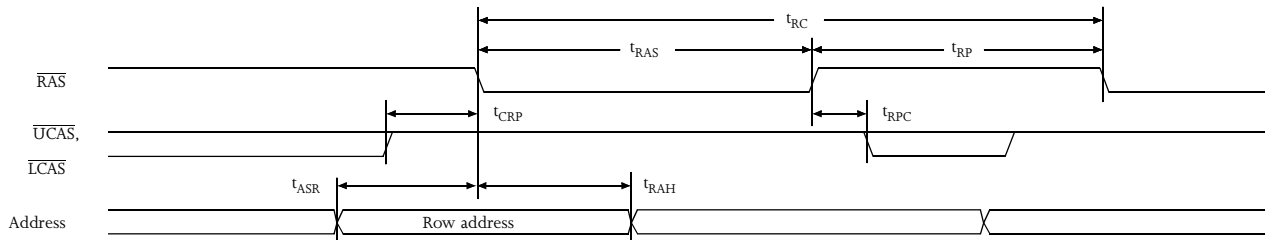



Hidden refresh waveform (read)

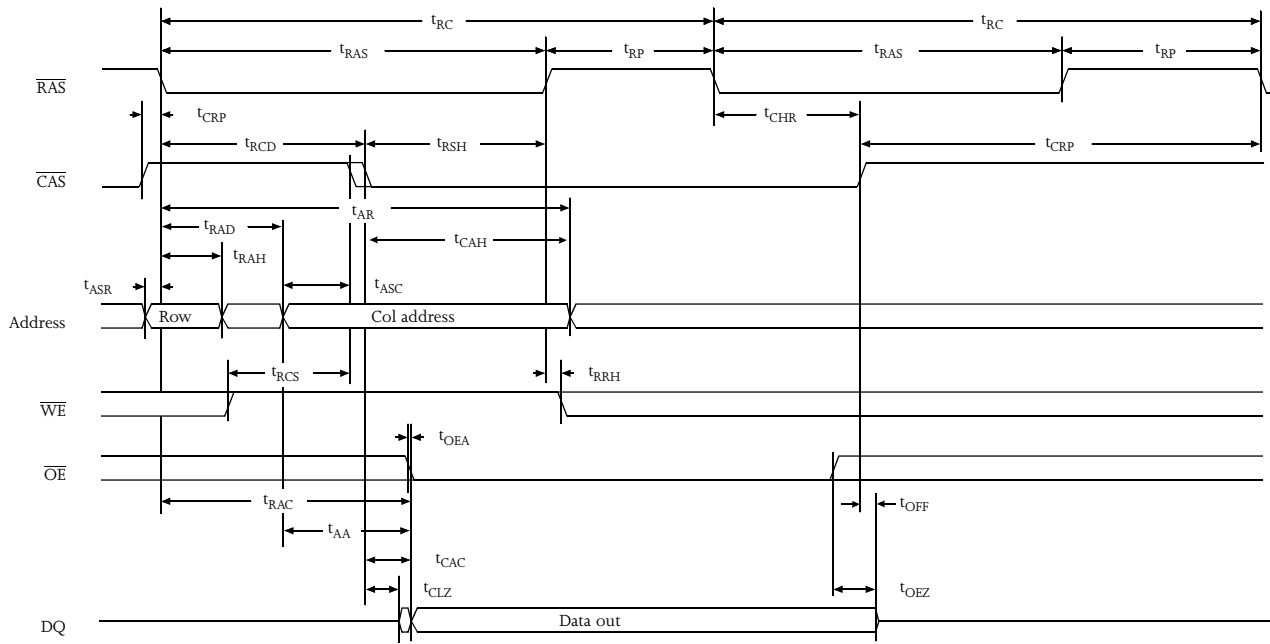

Hidden refresh waveform (write)

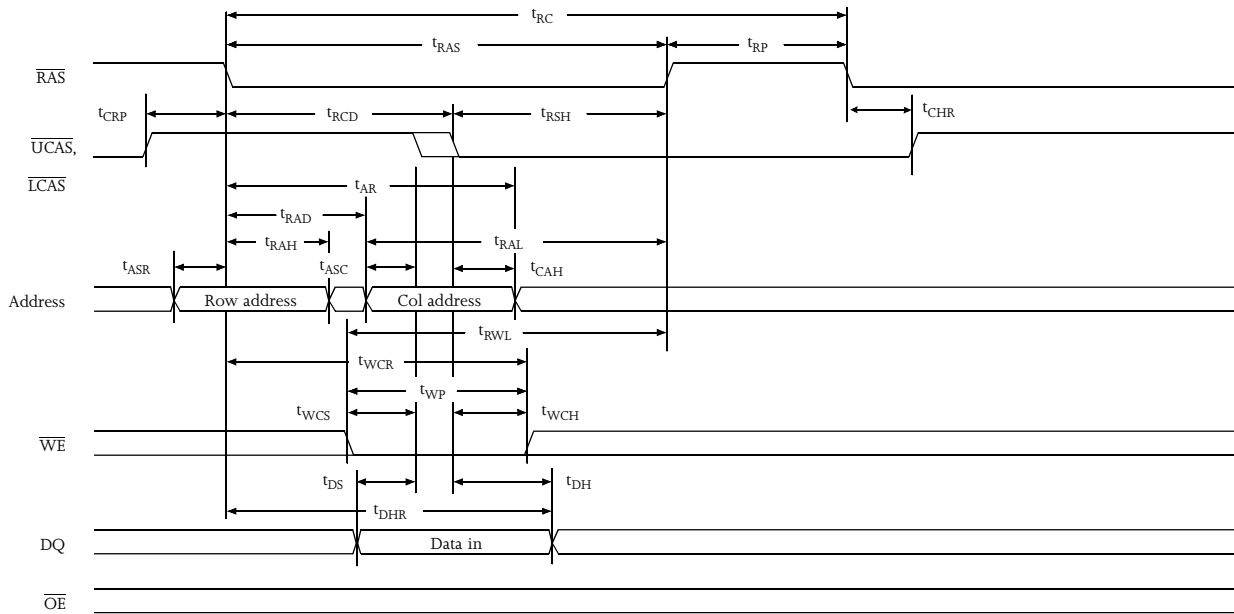



$\overline{\text{CAS}}$ before $\overline{\text{RAS}}$ refresh counter test waveform

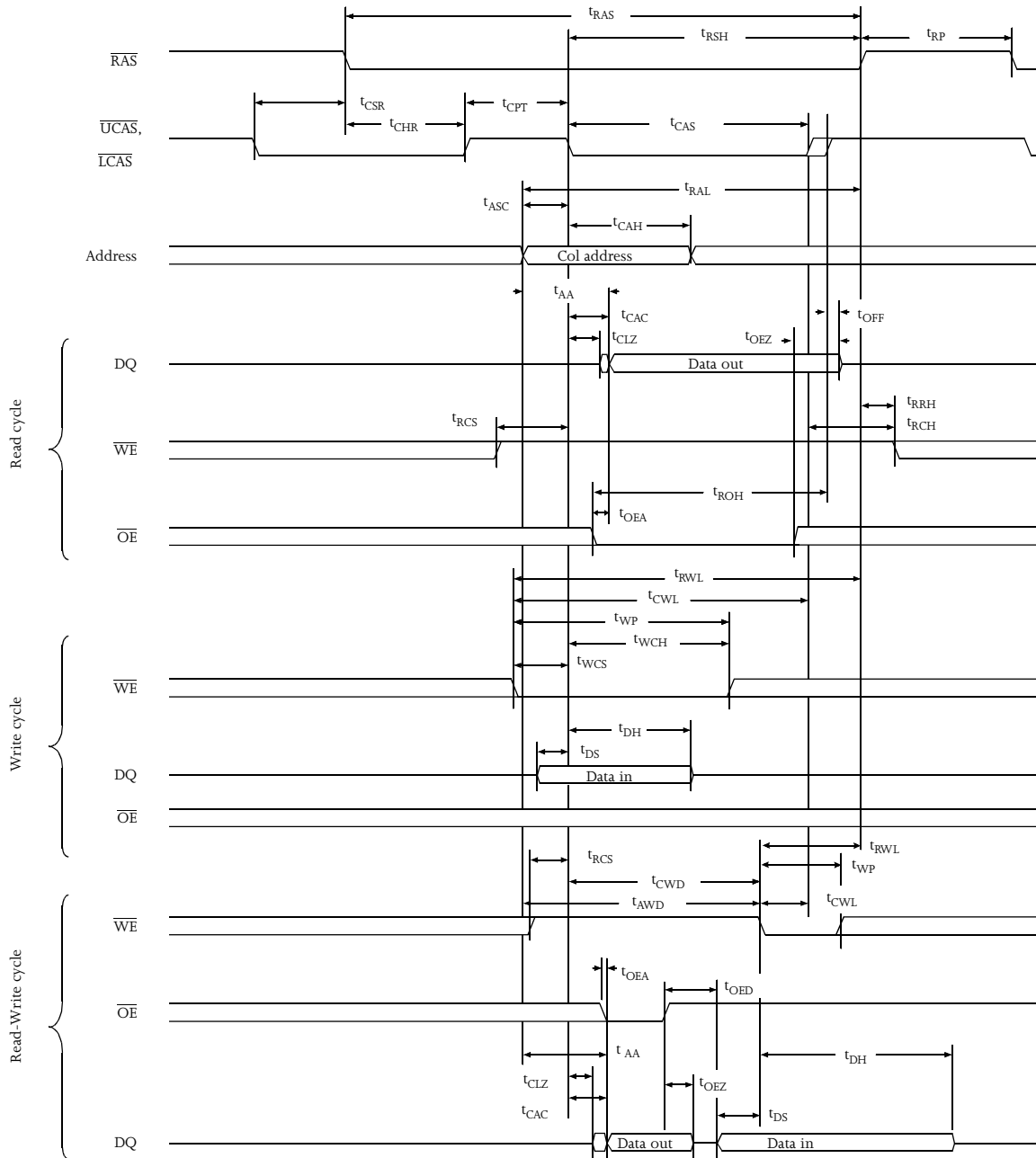



Package dimensions

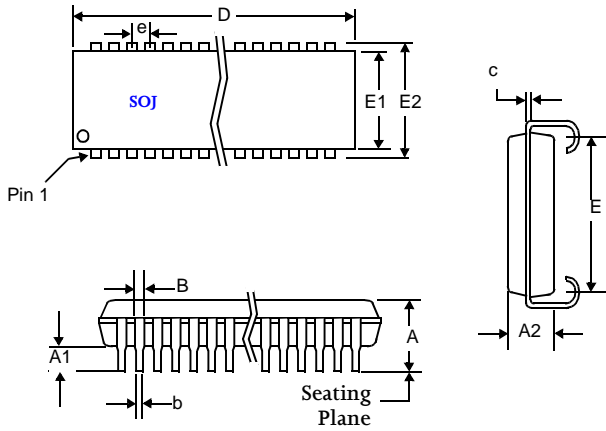

42-pin SOJ
400 mil

	Min	Max
A	0.128	0.148
A1	0.025	-
A2	0.105	0.115
B	0.026	0.032
b	0.015	0.020
c	0.007	0.013
D	1.070	1.080
E	0.370 NOM	
E1	0.395	0.405
E2	0.435	0.445
e	0.050 NOM	

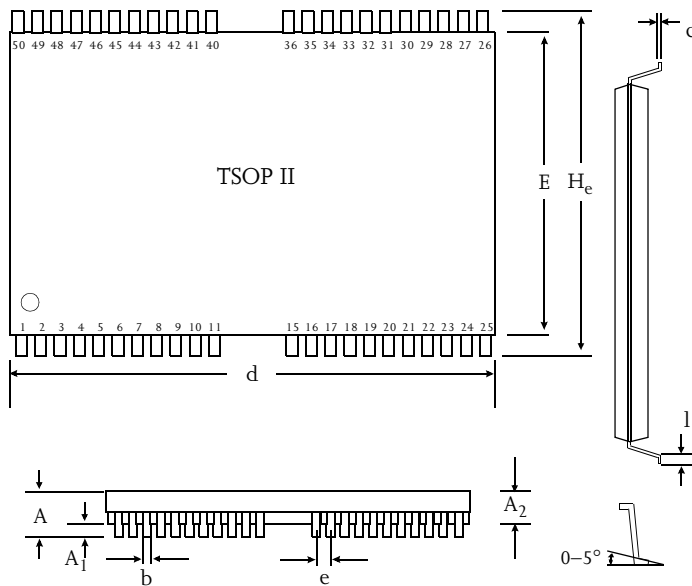

50-pin TSOP II

	Min (mm)	Max (mm)
A		1.2
A1	0.05	
A2	0.95	1.05
b	0.30	0.45
c	0.12	0.21
d	20.85	21.05
E	10.03	10.29
H _c	11.56	11.96
e	0.80 (typical)	
l	0.40	0.60



Typical DC and AC characteristics

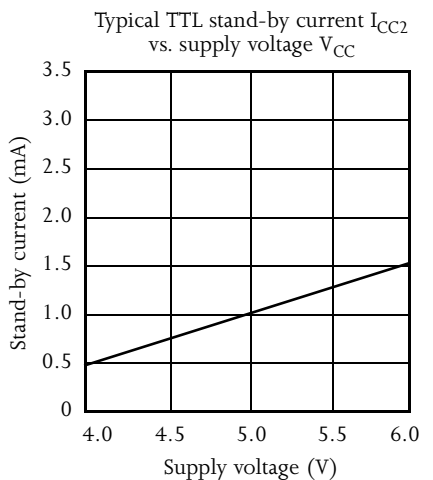
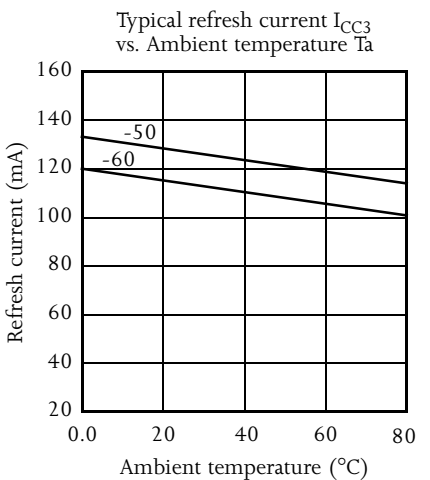
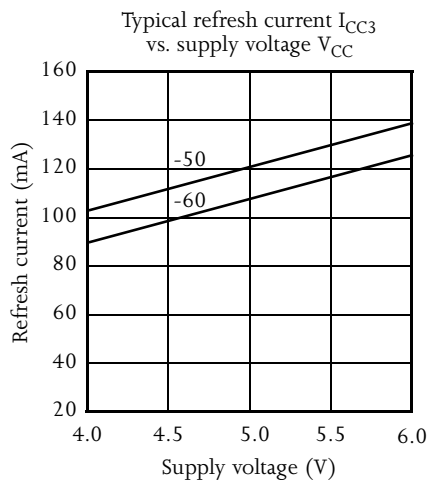
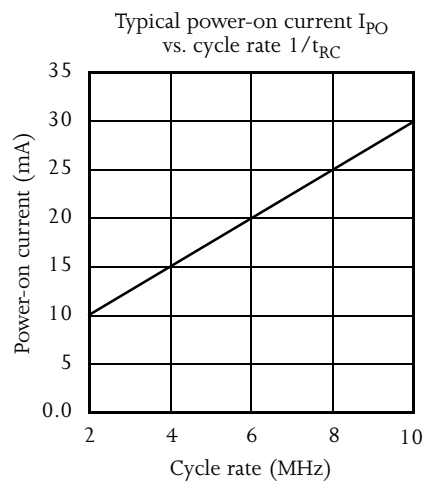
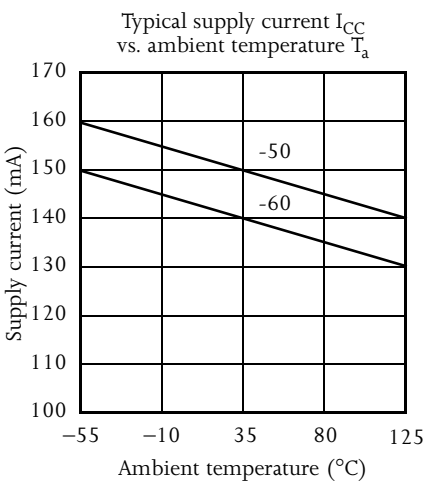
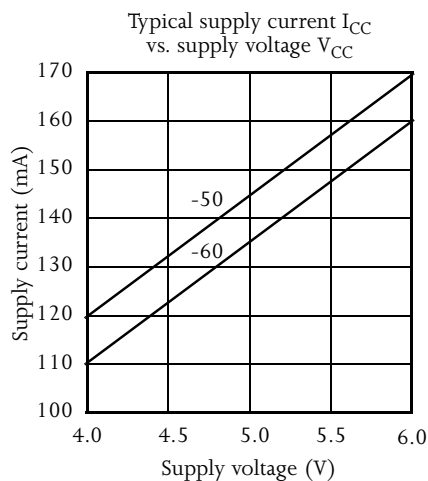
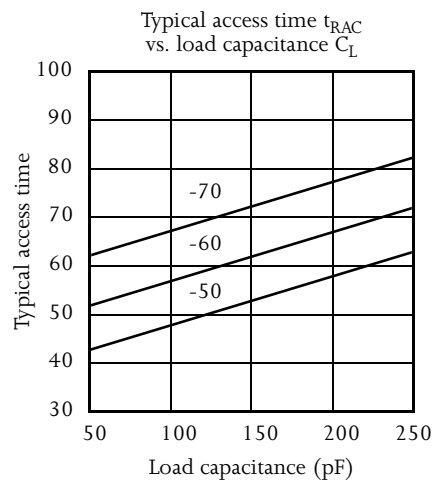
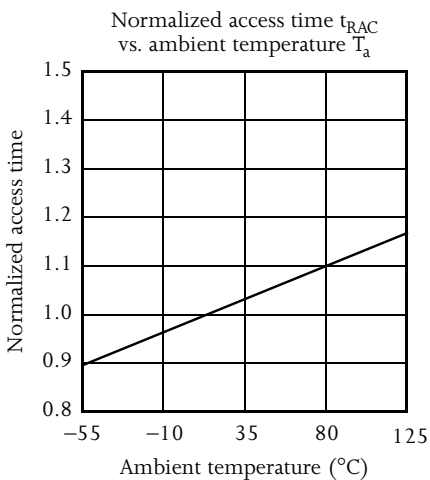
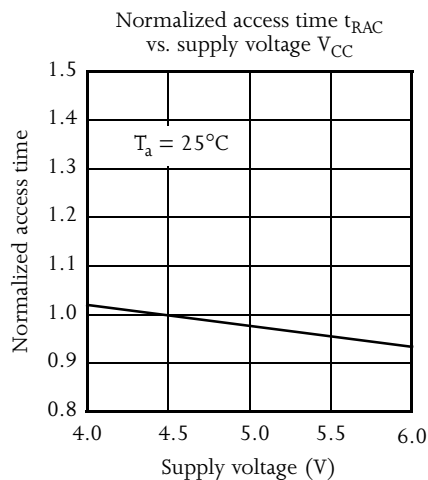

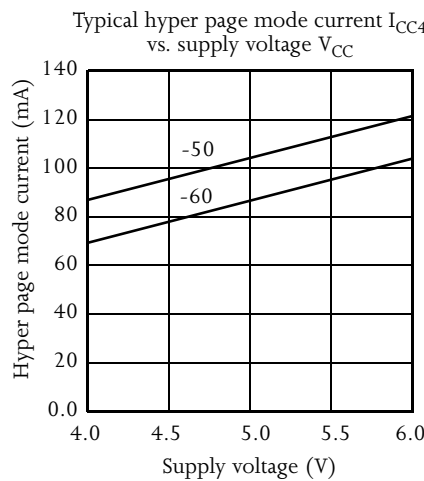
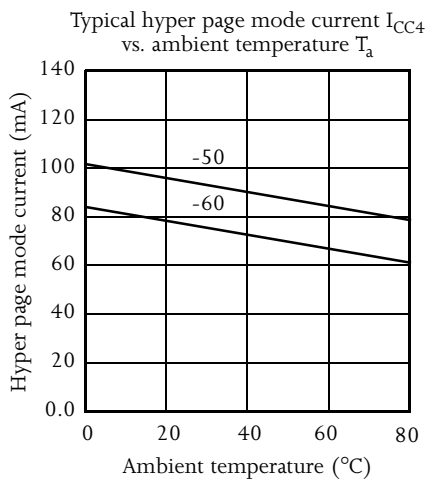
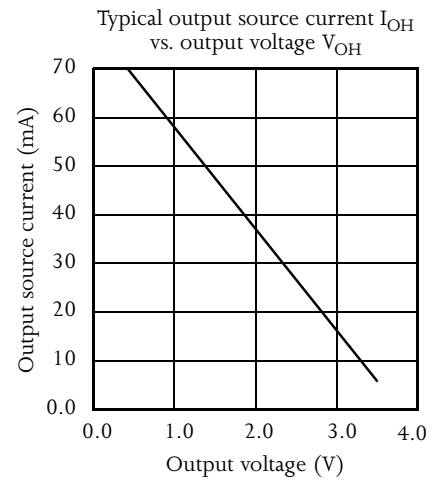
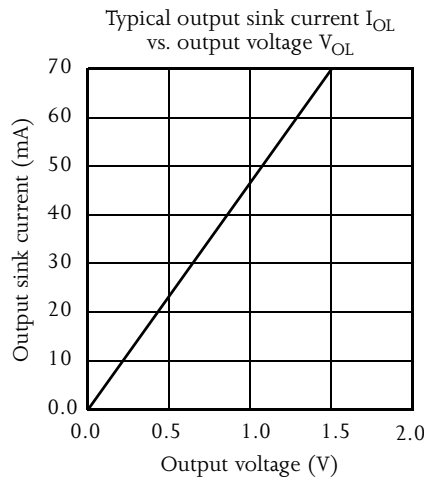
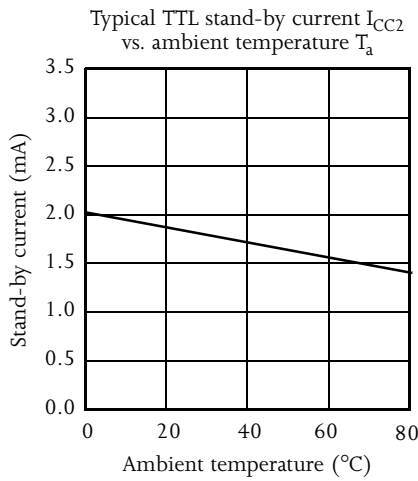

Capacitance ¹⁵

$f = 1 \text{ MHz}, T_a = \text{Room temperature}$

Parameter	Symbol	Signals	Test conditions	Max	Unit
Input capacitance	C_{IN1}	A0 to A9	$V_{in} = 0V$	5	pF
	C_{IN2}	$\overline{\text{RAS}}, \overline{\text{UCAS}}, \overline{\text{LCAS}}, \overline{\text{WE}}, \overline{\text{OE}}$	$V_{in} = 0V$	7	pF
DQ capacitance	C_{DQ}	DQ0 to DQ15	$V_{in} = V_{out} = 0V$	7	pF

AS4C1M16F5 ordering information

Package \ $\overline{\text{RAS}}$ access time	50 ns		60 ns
	Plastic SOJ, 400 mil, 42-pin	5V	AS4C1M16F5-50JC
AS4C1M16F5-50JI			AS4C1M16F5-60JI
TSOP II, 400 mil, 44/50-pin	5V	AS4C1M16F5-50TC	AS4C1M16F5-60TC
		AS4C1M16F5-50TI	AS4C1M16F5-60TI



AS4C1M16F5 part numbering system

AS4	C	1M16E0	-XX	X	X
DRAM prefix	C = 5V CMOS	Device number	$\overline{\text{RAS}}$ access time	Package: J = 42-pin SOJ 400 mil T=44/50-pin TSOP II 400 mil	Temperature range C=Commercial, 0°C to 70°C I=Industrial, -40°C to 85°C