

Features

- High-accuracy reference voltage circuit ($\pm 1\%$).
- Built-in short-circuit protection circuit.
- Built-in Undervoltage Lockout protection.
- Internal 2.5V Reference supply.
- Variable Dead time provides control over total Range.

Applications

- LCD Display
- Portable equipment

General Description

The AT1743 is 2-channel PWM switching regulator controllers that contains an on-chip 2.5V reference, two error amplifier, an adjustable oscillator, two dead-time comparators, under-voltage lockout circuitry and 2 common-emitter output. It is idea for step-up, step-down, and inverting converter.

Block Diagram

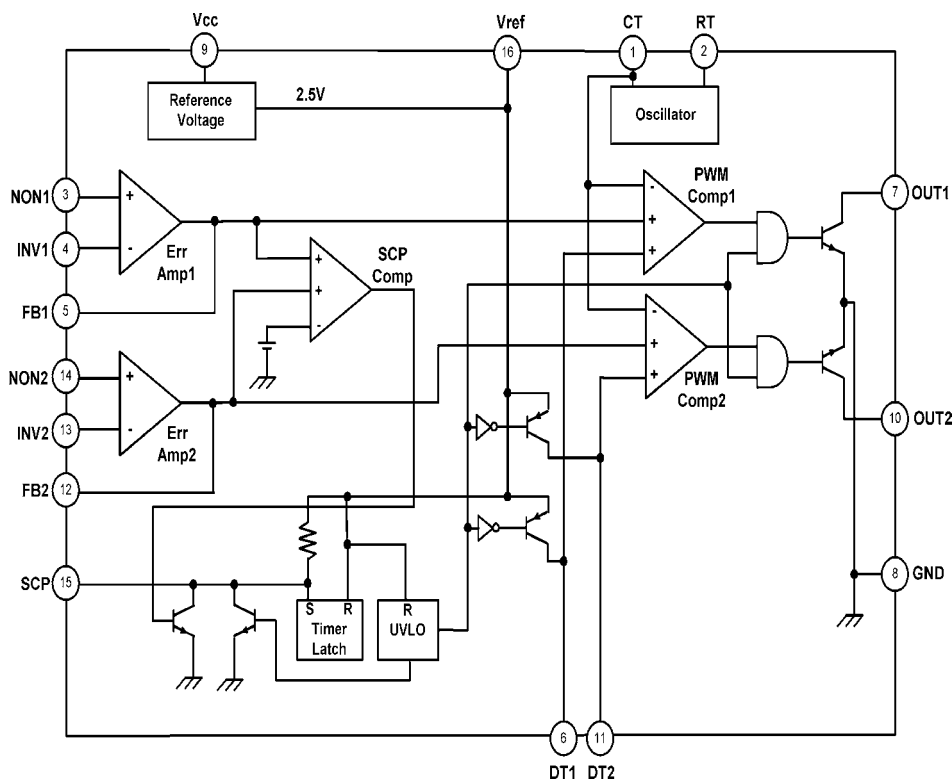

Pin Configuration

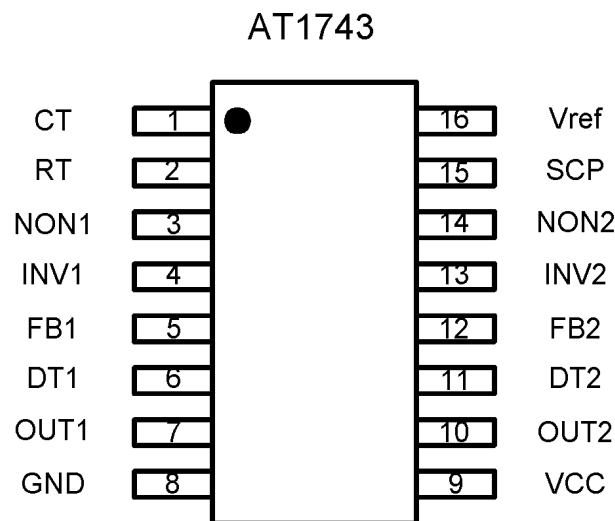

Ordering Information

Part number	Package	Marking
AT1743	TSSOP16	AT1743P
-	-	-

Pin Description

Pin No.	Symbol	I/O	Description
1	CT	--	External timing capacitor
2	RT	--	External timing resistor
3	NON1	I	Positive input for error amplifier 1
4	INV1	I	Negative input for error amplifier 1
5	FB1	O	Error amplifier 1 output
6	DT1	I	Output 1 dead time / soft start setting
7	OUT1	O	Output 1
8	GND	--	Ground
9	Vcc	--	Power supply
10	OUT2	O	Output 2
11	DT2	I	Output 2 dead time / soft start setting
12	FB2	O	Error amplifier 2 output
13	INV2	I	Negative input for error amplifier 2
14	NON2	I	Positive input for error amplifier 2
15	SCP	--	Time latch setting
16	Vref	O	Reference voltage output (2.5V)

Absolute Maximum Ratings

(Ta=+25°C)

Parameter	Symbol	Limits	Unit
Power supply voltage	V _{cc}	30	V
Power dissipation	P _d	450* ¹	mW
Operating temperture	T _{opr}	-30~+85	°C
Storage temperture	T _{stg}	-55~+125	°C
Output current	I _o	120* ²	mA
Output voltage	V _o	30	V

* 1 When mounted on 70mm×70mm×1.6mm glass epoxy board. Reduced by 6.5mw for each increase in Ta of 1°C over 25°C.

* 2 Should not exceed Pd and values.

Recommended Operating Conditions

(Ta=+25°C)

Parameter	Symbol	Values			Unit
		Min.	Typ.	Max.	
Power supply voltage	V _{CC}	3.6	6.0	25	V
Output current	I _o	--	--	100	mA
Output voltage	V _o	--	--	25	V
Error amplifier input voltage	V _{OM}	0.3	--	1.6	V
Timing capacitor	C _{CT}	100	--	15000	pF
Timing resistor	R _{RT}	5.1	--	50	kΩ
Oscillator frequency	F _{OSC}	10	--	800	kHz

Timing chart

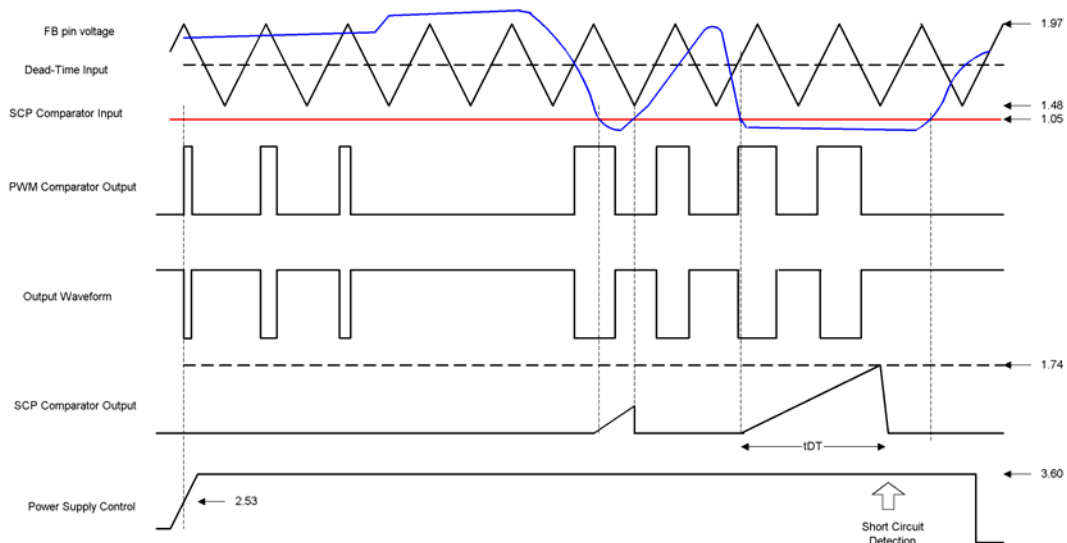

Electrical Characteristics

(unless otherwise noted, Ta=25°C, and Vcc=6V)

Parameter	Symbol	Condition	Values			Unit	
			Min.	Typ.	Max.		
Reference voltage block	Output voltage	Vref	Iref=1mA	2.48	2.5	2.53	V
	Input stability	V _{DLI}	Vcc=3.6~25V	--	1	10	mV
	Load stability	V _{DLO}	Iref=0~5mA	--	1	10	mV
Triangular wave oscillator	Oscillation frequency	Fosc	R _{RT} =10kΩ, C _{CT} =220pF	320	400	480	kHz
	Frequency deviation	F _{DV}	Vcc=3.6~25V	--	1	--	%
Protection circuit	Threshold voltage	V _{IT}	--	1.48	1.64	1.80	V
	Standby voltage	V _{STB}	No pull up	--	50	100	mV
	Latch voltage	V _{LT}	No pull up	--	30	100	mV
	Source current	I _{SCP}	--	1.5	2.5	3.5	μA
	Comparator threshold voltage	V _{CT}	Pin 5, Pin 12	0.9	1.05	1.2	V
Rest period adjustment circuit	Input threshold voltage (fosc=10kHz)	V _{I0}	Duty cycle=0%	1.79	1.97	2.15	V
		V _{I100}	Duty cycle=100%	1.32	1.48	1.64	V
	On duty cycle	D _{ON}	Divide Vref using 13 kΩ and 27 kΩ	45	55	65	%
	Input bias current	I _{BDT}	DT1, DT2=2.0V	--	0.1	1	μA
	Latch mode source current	I _{DT}	DT1, DT2=0V	200	560	--	μA
	Latch input voltage	V _{DT}	I _{DT} =40 μA	2.28	2.48	--	V
Low-voltage input miss-operation prevention circuit	Threshold voltage	V _{UT}	--	--	2.53	--	V
Error amplifier	Input offset voltage	V _{IO}	--	--	--	6	mV
	Input offset current	I _{IO}	--	--	--	30	nA
	Input bias current	I _{IB}	--	--	15	100	nA
	Open circuit gain	AV	--	70	85	--	dB
	Common-mode input voltage range	V _{OM}	Vcc=3.6~25V	0.3	--	1.6	V
	Common-mode rejection ratio	CMRR	--	60	80	--	dB
	Maximum output voltage	V _{OH}	--	2.3	2.5	--	V
	Minimum input voltage	V _{OL}	--	--	0.7	0.9	V
	Output sink current	I _{OI}	FB=1.25V	3	20	--	mA
Output source current	I _{OO}	FB=1.25V	45	75	--	μA	
PWM comparator	Input threshold voltage (fosc=10kHz)	V _{I0}	Duty cycle=0%	1.79	1.97	2.15	V
		V _{I100}	Duty cycle=100%	1.32	1.48	1.64	V
Output block	Saturation voltage	V _{SAT}	I _o =75mA	--	0.8	1.2	V
	Leak current	I _{REAK}	V _o =25V	--	0	5	μA
Total device	Standby current	I _{CCS}	When output is off	--	1.3	1.8	mA
	Average current consumption	I _{CCA}	R _{RT} =10 kΩ	--	1.6	2.3	mA

Timing Curve

Ambient Temperature vs. Reference Voltage Variation

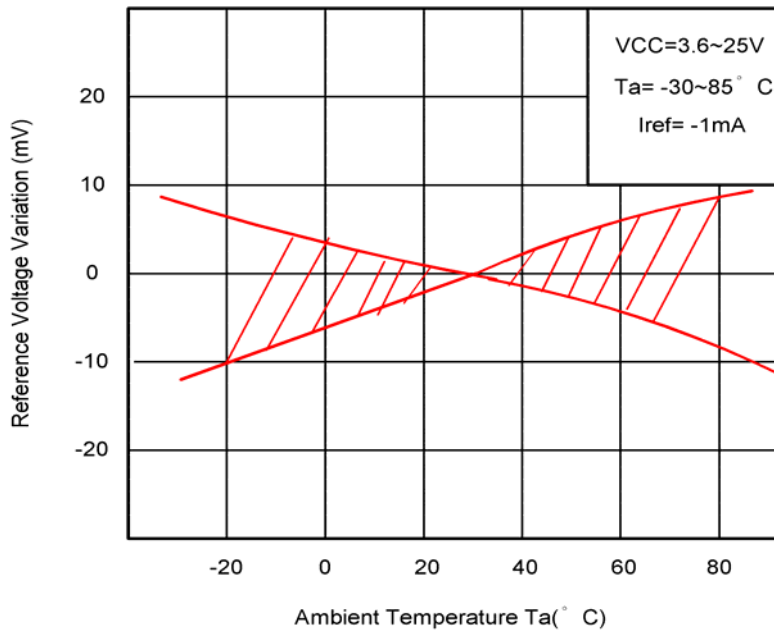

Output Saturation Voltage vs. Output Current

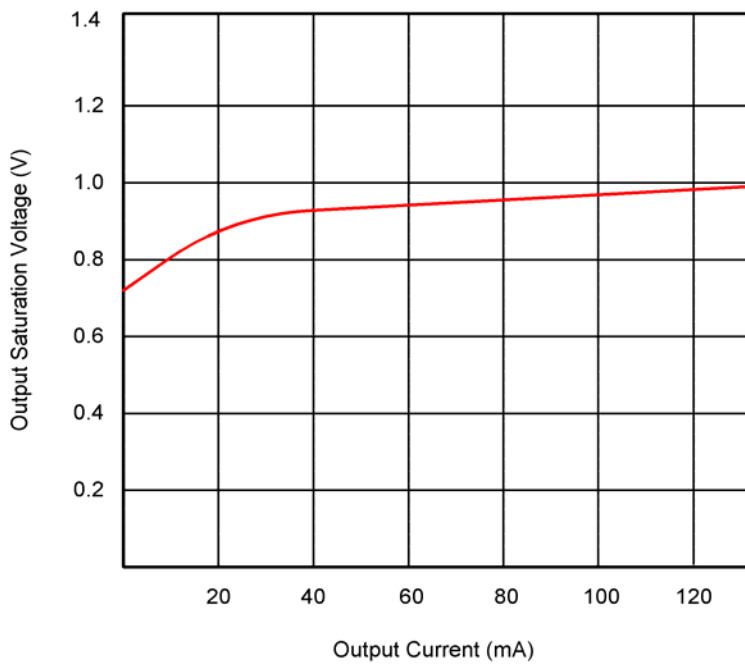

Standby Current vs. Supply Voltage

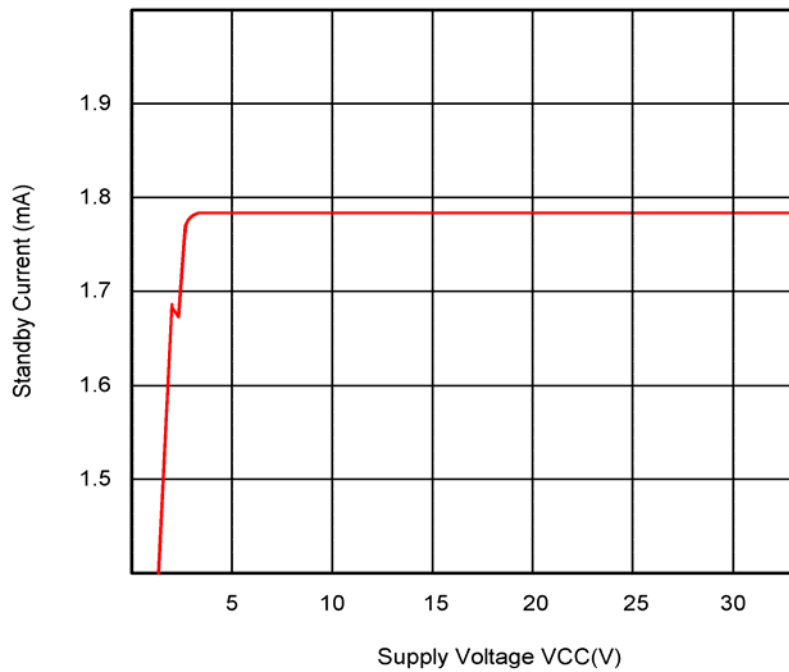

Supply Voltage vs. Reference voltage

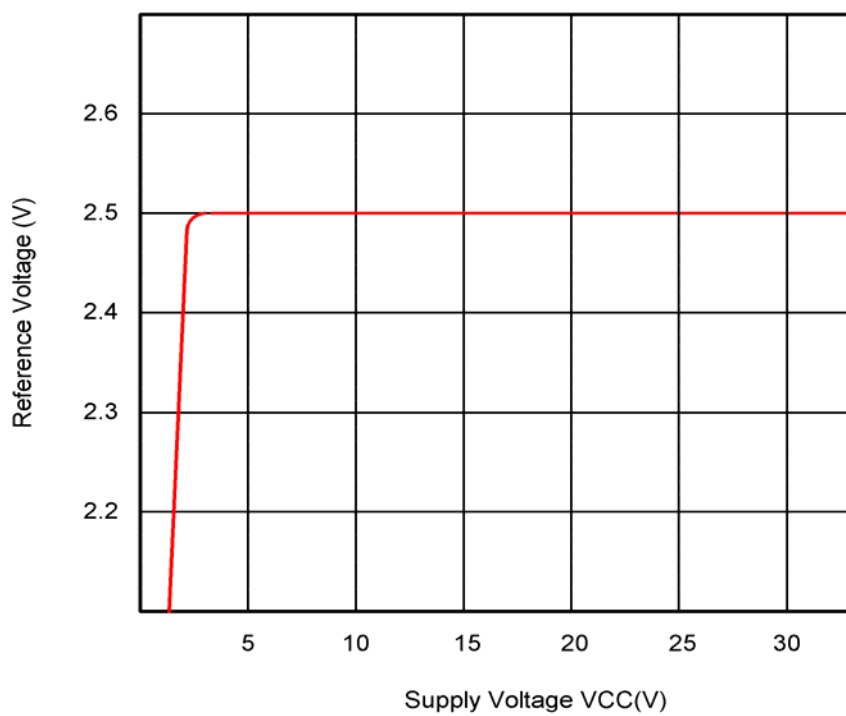

Application Circuit: Step-Down converter

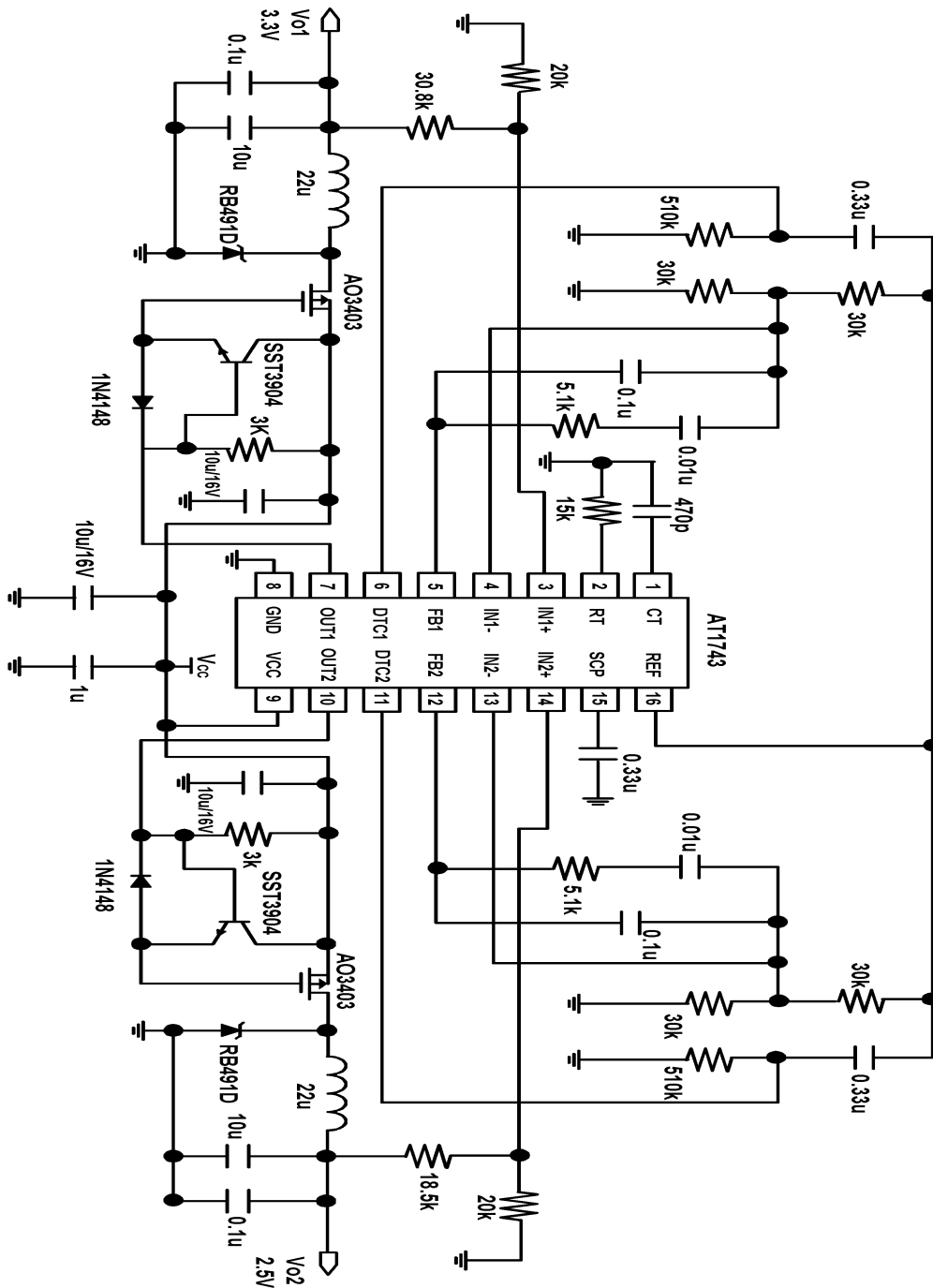

Package Outline 16-pin TSSOP

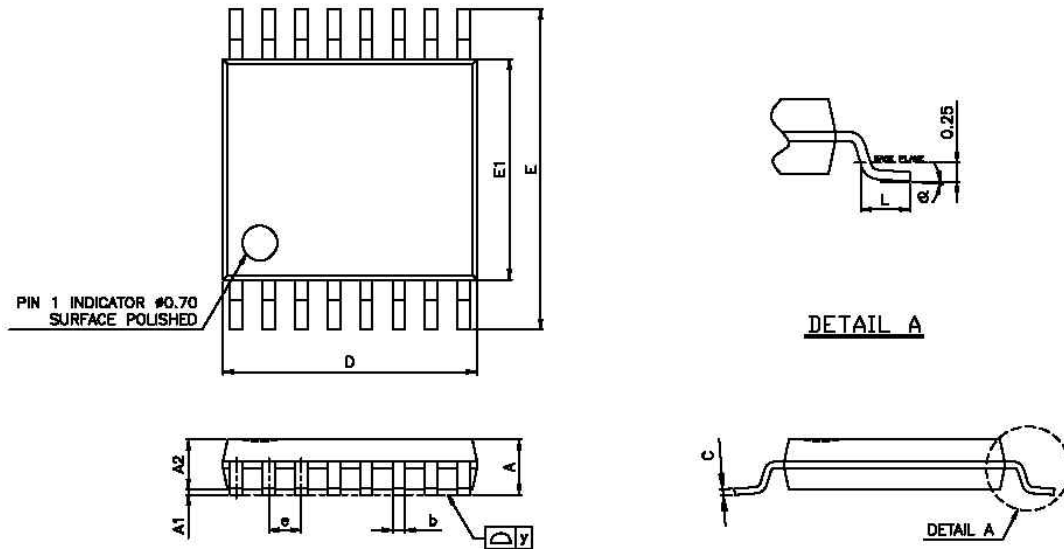

SYMBOL	MILLIMETERS			INCHES		
	MIN	TYP	MAX	MIN	TYP	MAX
A	1.05	1.10	1.20	0.041	0.043	0.047
A1	0.05	0.10	0.15	0.002	0.004	0.006
A2	-	1.00	1.05	-	0.039	0.041
b	0.20	0.25	0.28	0.008	0.010	0.011
C	-	0.127	-	-	0.005	-
D	4.90	5.075	5.10	0.193	0.1998	0.200
E	6.20	6.40	6.60	0.244	0.252	0.260
E1	4.30	4.40	4.50	0.170	0.173	0.177
L	0.50	0.60	0.70	0.020	0.024	0.028
e	-	0.65	-	-	0.026	-
y	-	-	0.076	-	-	0.003
θ	0°		8°	0°		8°

Reflow Condition (IR/Convection or VPR Reflow)

Reference JEDEC Standard J-STD-020A

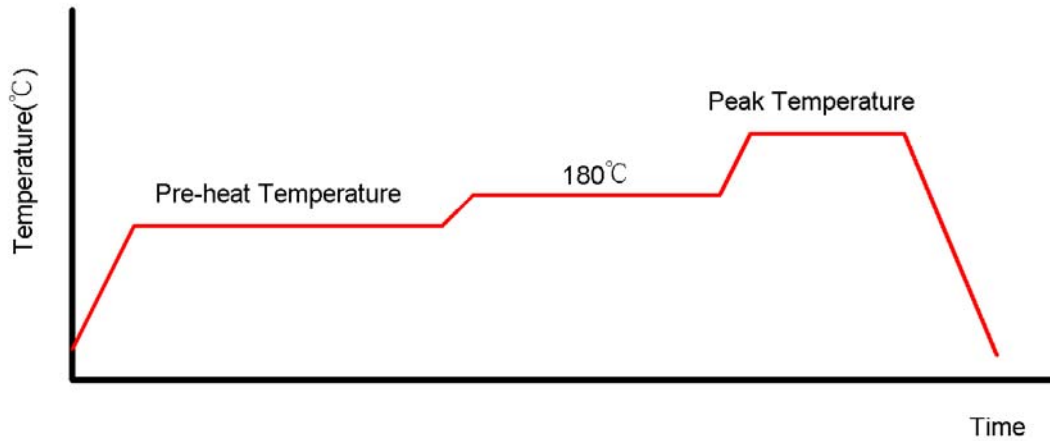

Classification Reflow Profiles

	Convection or IR/Convection	VPR
Average Heating Rate(180°C to peak)	5°C/second max.	10°C/second max.
Preheat Temperature(125±20°C)	120 seconds max.	
Temperature maintained above 180°C	10~150 seconds	
Time within 5°C of actual Peak Temperature	10~20 seconds	60 seconds
Peak Temperature Range(Note 1)	219~225°C or 235~240°C	219~225°C or 235~240°C
Cooling Rate	6°C /second max.	10°C/second max.
Time 25°C to Peak Temperature	6 minutes max.	

*1 The maximum peak temperatures for IR and VP reflow are depending on package dimensions.

Package Reflow Conditions

Pkg. Thickness ≥2.5mm and all bags	Pkg. Thickness <2.5mm and Pkg. Volume ≥350 mm ³	Pkg. Thickness <2.5mm and Pkg. Volume <350 mm ³
Convection 219~225°C		Convection 235~240°C
VPR 219~225°C		VPR 235~240°C
IR/Convection 219~225°C		IR/Convection 235~240°C