

Features

- 1 CH(Forward-reverse) control DC motor driver
- 4 CH BTL(Balanced Transformerless) driver
- Built-in Thermal shutdown circuit
- Built-in 5V regulator (with an external PNP TR)
- Built-in mute circuit
- Built-in Tray motor speed control circuit
- Wide operating supply voltage range: 6V~13.2V

General Description

The AT5659 is a monolithic integrated circuit, and suitable for 5-ch motor driver which drives focus actuator, tracking actuator, sled motor, spindle motor and Tray motor of CDP & VCD system.

Applications

- CD-PLAYER
- VIDEO-CD
- CAR-CD

Block Diagram

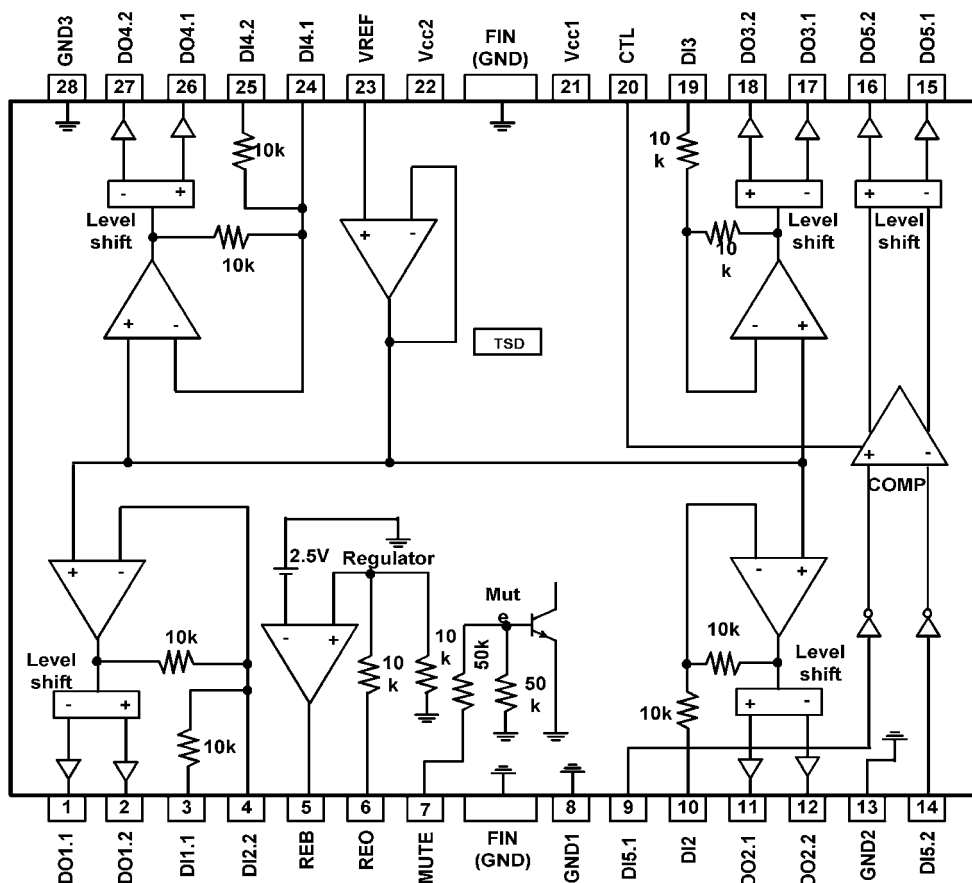

Aimtron reserves the right without notice to change this circuitry and specifications.

Pin Configuration

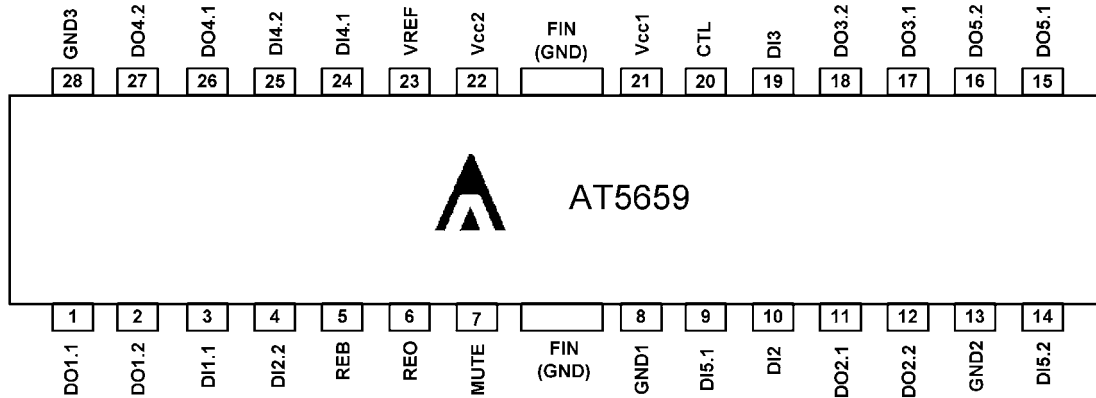

Ordering Information

Part number	Package	Marking
AT5659H	28-pin HSOP	AT5659H

Pin Description

Pin No.	Symbol	Descript	Pin No.	Symbol	Descript
1	DO1.1	CH1 output (-)	15	DO5.1	CH5 output (+)
2	DO1.2	CH1 output (+)	16	DO5.2	CH5 output (-)
3	DI1.1	CH1 input 1	17	DO3.1	CH3 output (-)
4	DI1.2	CH1 input 2 (Adjustable)	18	DO3.2	CH3 output (+)
5	REB	Regulator base	19	DI3	CH3 input
6	REO	Regulator output, 5V	20	CTL	CH5 motor speed control
7	MUTE	Mute	21	V _{CC1}	Supply voltage 1
8	GND1	Ground 1	22	V _{CC2}	Supply Voltage 2
9	DI5.1	CH5 input 1	23	VREF	CH bias input
10	DI2	CH2 input	24	DI4.1	CH4 input 1 (Adjustable)
11	DO2.1	CH2 output (+)	25	DI4.2	CH4 input 2
12	DO2.2	CH2 output (-)	26	DO4.1	CH4 output (+)
13	GND2	Ground 2	27	DO4.2	CH4 output (-)
14	DI5.2	CH5 input 2	28	GND3	Ground 3

Absolute Maximum Ratings

(Ta=+25°C)

Parameter	Symbol	Limits	Unit
Maximum supply voltage	V _{CCMAX}	13.5	V
Power dissipation	P _D	*1.7	W
Operating temperature	T _{OPR}	-25~+75	°C
Storage temperature	T _{STG}	-55~+150	°C
Maximum current output	I _{OMAX}	1	A

NOTE:*

1. When mounted on 76mm×114mm×1.57mm PCB (Phenolic resin material).
2. Power dissipation reduces 13.6mW / °C for using above Ta=25°C
3. Do not exceed Pd and SOA.

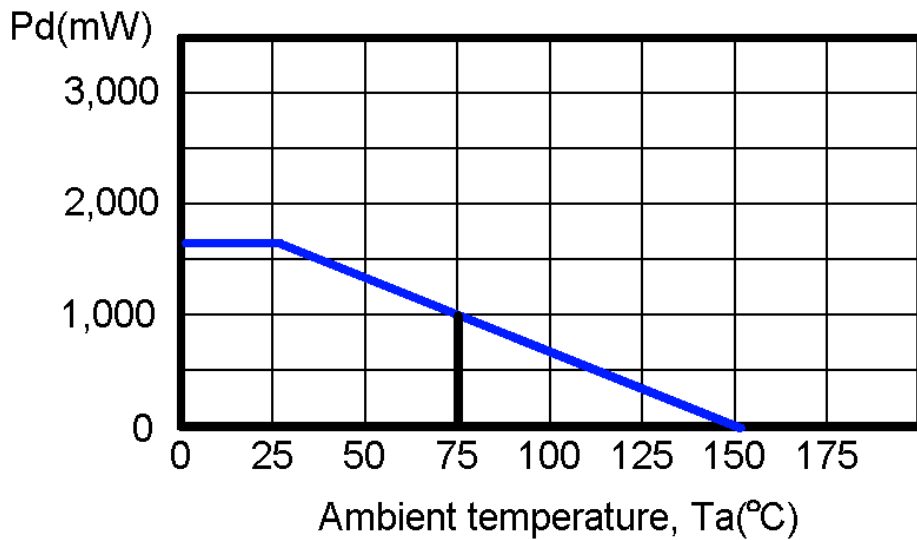

Recommended Operating Conditions

(Ta=+25°C)

Parameter	Symbol	Values			Unit
		Min.	Typ.	Max.	
Operatong supply voltage	Vcc	5.5	--	13.2	V

Electrical Characteristics

(unless otherwise noted, $T_a=25^{\circ}\text{C}$, $V_{CC1}=V_{CC2}=8\text{V}$, $R_L=8\Omega$, and $f=1\text{kHz}$)

Parameter	Symbol	Condition	Values			Unit	
			Min.	Typ.	Max.		
Total Device	Quiescent circuit current	I_{CCQ}	Under no-load	7	10	15	mA
	Mute-on current	I_{MUTE}	Pin 7=GND	--	4	7	mA
	Mute-on voltage	V_{MON}	--	--	--	0.5	V
	Mute-off voltage	V_{MOFF}	--	2	--	--	V
Regulator	Output voltage	V_{REG}	$I_L=100\text{mA}$	4.7	5.0	5.3	V
	Load regulation	ΔV_{RL3}	$I_L=0\sim 200\text{mA}$	-50	0	50	mV
	Line regulation	ΔV_{CC}	$V_{CC}=6\sim 13\text{V}$, $I_L=100\text{mA}$	-20	0	80	mV
BTL Driver (Except for Tray motor driver)	Input offset voltage	V_{IO}	--	-15	--	15	mV
	Output offset voltage 1	V_{OO1}	--	-40	--	40	mV
	Maximum source current 1	$I_{SOURCE1}$	$R_L=8\Omega \rightarrow V_{CC}$	0.25	0.4	--	A
	Maximum sink current 1	I_{SINK1}	$R_L=8\Omega \rightarrow \text{GND}$	0.25	0.4	--	A
	Maximum output voltage 1	V_{OM1}	$V_{IN}=0.7\text{V}$	2.5	3.3	--	V
	Maximum output voltage 2	V_{OM2}	$V_{IN}=7\text{V}$	--	-4.5	-3.7	V
	Closed-loop voltage gain	A_{VF}	$V_{IN}=0.1V_{RMS}$	5	6.5	8	dB
	Ripple rejection ratio	RR	$V_{IN}=0.1V_{RMS}$, $f=120\text{Hz}$	40	60	--	dB
	Slew rate	SR	120Hz, $V_{IN}=1V_{RMS}$, Square wave	1	2	--	V/ μs
Tray Motor Driver (Unless otherwise specified, $V_{CTL}=\text{opened}$)	Output voltage 1	V_{O1}	$V_{PIN9}=5\text{V}$, $V_{PIN14}=0\text{V}$, $R_L=45\Omega$	2.5	3.1	3.8	V
	Output voltage 2	V_{O2}	$V_{PIN9}=0\text{V}$, $V_{PIN14}=5\text{V}$, $R_L=45\Omega$	2.5	3.1	3.8	V
	Output voltage regulation 1 (CTL)	V_{OCTL1}	$V_{CTL}=3.5\sim 4.5\text{V}$, $V_{PIN9}=5\text{V}$, $V_{PIN14}=0\text{V}$, $R_L=45\Omega$	0.5	1.0	1.5	V
	Output voltage regulation 2 (CTL)	V_{OCTL2}	$V_{CTL}=3.5\sim 4.5\text{V}$, $V_{PIN9}=0\text{V}$, $V_{PIN14}=5\text{V}$, $R_L=45\Omega$	0.5	1.0	1.5	V
	Load regulation 1	ΔV_{RL1}	$I_L=100\sim 400\text{mA}$, $V_{PIN9}=5\text{V}$, $V_{PIN14}=0\text{V}$	--	300	700	mV
	Load regulation 2	ΔV_{RL2}	$I_L=100\sim 400\text{mA}$, $V_{PIN9}=0\text{V}$, $V_{PIN14}=5\text{V}$	--	300	700	mV
	Output offset voltage 2	V_{OO2}	$V_{PIN9}=5\text{V}$, $V_{PIN14}=5\text{V}$	-40	--	40	mV
	Output offset voltage 3	V_{OO3}	$V_{PIN9}=0\text{V}$, $V_{PIN14}=0\text{V}$	-40	--	40	mV

Application Information

1. Mute

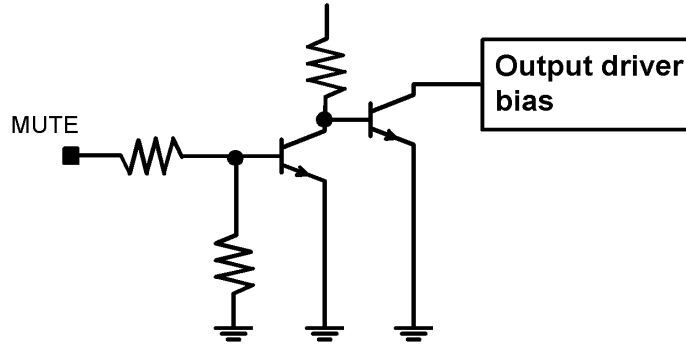

MUTE	Mute circuit
High(>2.0V)	Turn-OFF
Low(<0.5V)	Turn-ON
Open	Turn-ON

2. Thermal Shutdown

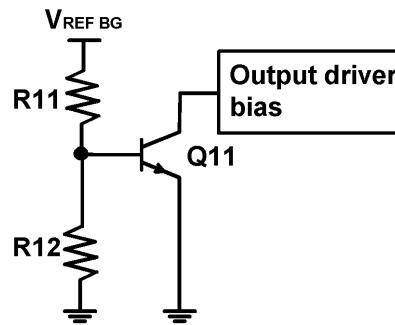

- The V_{REFBG} is the output voltage of the band-gap-referenced biasing circuit and acts as the input voltage of the TSD circuit. The base-emitter voltage of the TR, Q11 is designed to turn-on at below voltage.

$$V_{BE} = V_{REFBG} \times R12 / (R11+R12) = 460mV$$

- When the chip temperature rises up to 175°C, then the turn-on voltage of the Q11 would drop down to 460mV.(Hysteresis: 25°C), the Q11 would turn on so the output circuit will be muted.

3. Regulator

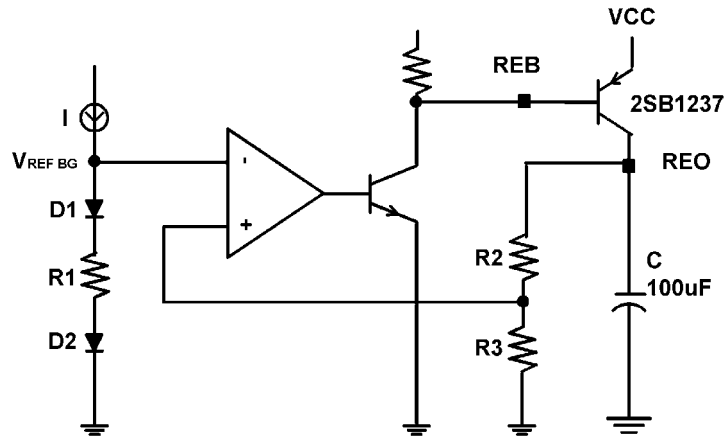

$$V_{OUT} = V_{REFBG} \times 2 = 2.5 \times 2 = 5V \quad (R2 = R3)$$

4. BTL Driver(Except for Tray Motor Driver)

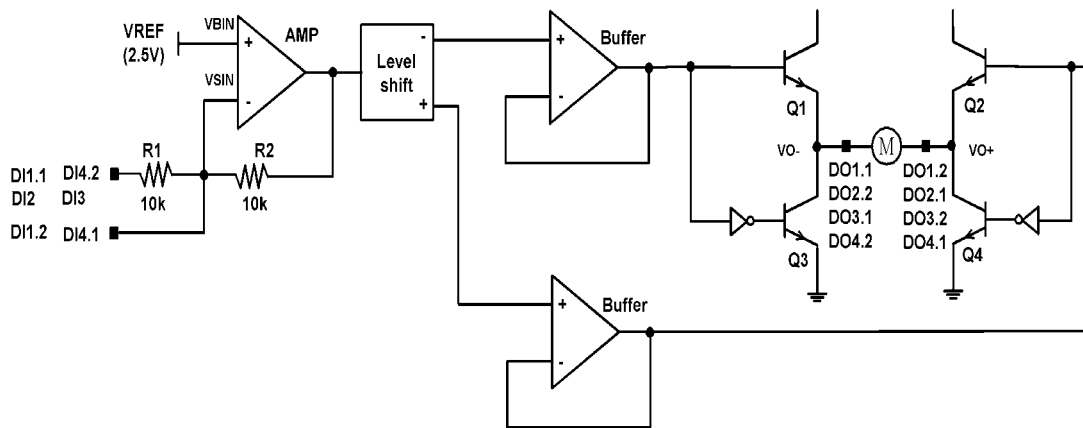

$$Gain(dB) \approx 20 \times \log\left(2 \times \frac{R2}{R1}\right)$$

- The voltage, V_{REF} , is the reference voltage given by the bias voltage of the pin 23. It can be reduced the total gain of BTL drive part, use additional series resistor into the input pin (pin3,10,19,25). It can also increase or decrease the voltage gain of the CH1,CH4 using adjustable pin (pin4,24) by inserting an external series resistor.

Input	Output		
	VO+	VO-	Status
VSIN > VBIN	High	Low	Forward
VSIN = VBIN	VP	VP	Break
VSIN < VBIN	Low	High	Reverse

$$* VP = \frac{1}{2} VCC1$$

5. Tray Driver

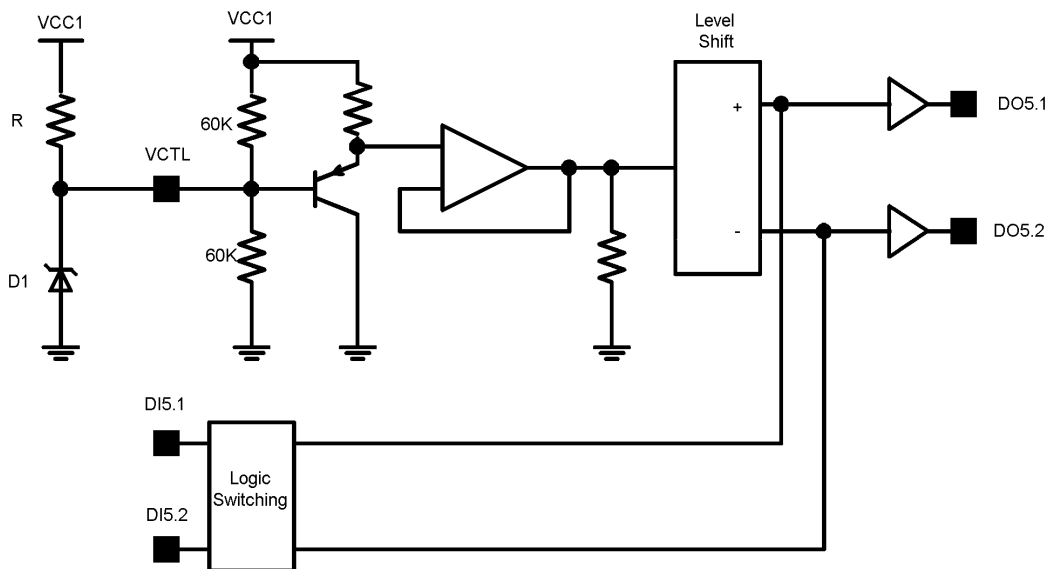

Input		Output		
DI5.1	DI5.2	OUT5.1	OUT5.2	Status
High	High	VP	VP	Break
High	Low	High	Low	Forward
Low	High	Low	High	Reverse
Low	Low	VP	VP	Break

$$* VP = \frac{1}{2} VCC1$$

Tray Motor Speed Control:

The amplitude of the output voltage is controlled by VCTL(pin20). Normally, the differential output voltage is VP when the VCTL is open. If you want to control differential output voltage of the tray, insert external resistor R and zener diode D1 as shown in figure 1. Zener diode D1 is only needed when you want to obtain a precision output voltage. In other case you only insert an external resistor R.

- 5. If the bias pin (23pin) drops below 1.4V, the output current is muted. Make sure that under normal operating conditions, this pin is at 1.6V or above.**
- 6. If the power supply voltage drops below 4.5V typ., the drivers are turned OFF. When the voltage exceeds 4.7V typ., the drivers return to their previous state.**

Typical Application Circuit

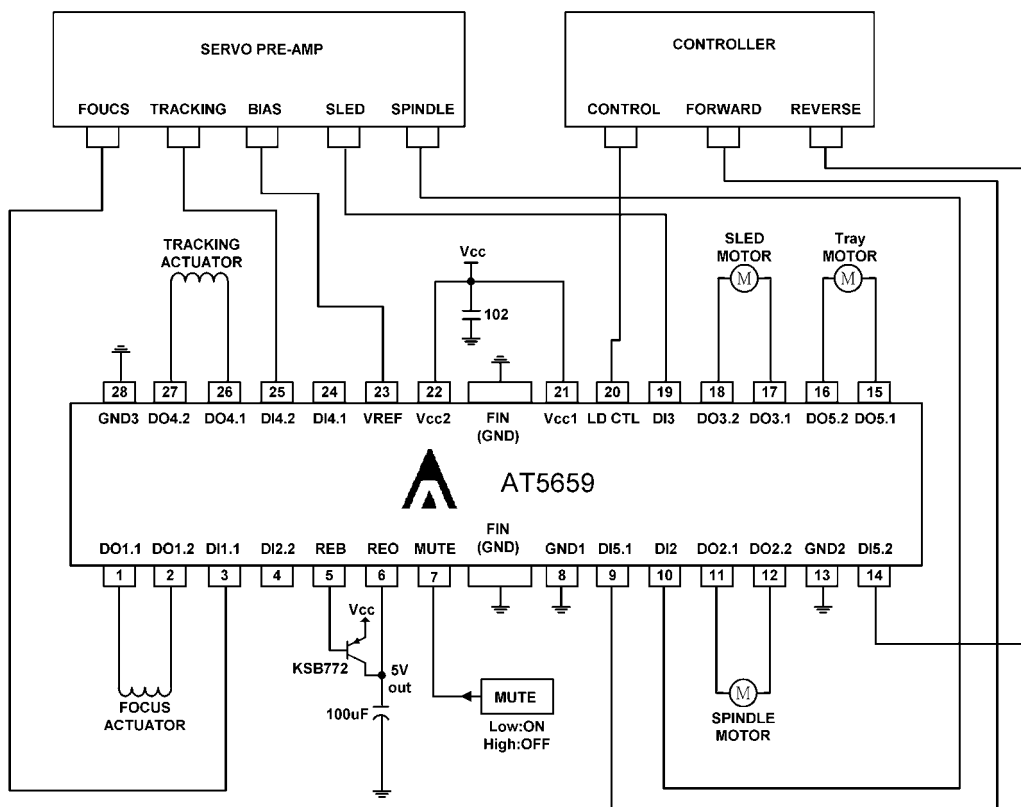

VCD Player Motor Driver Circuit

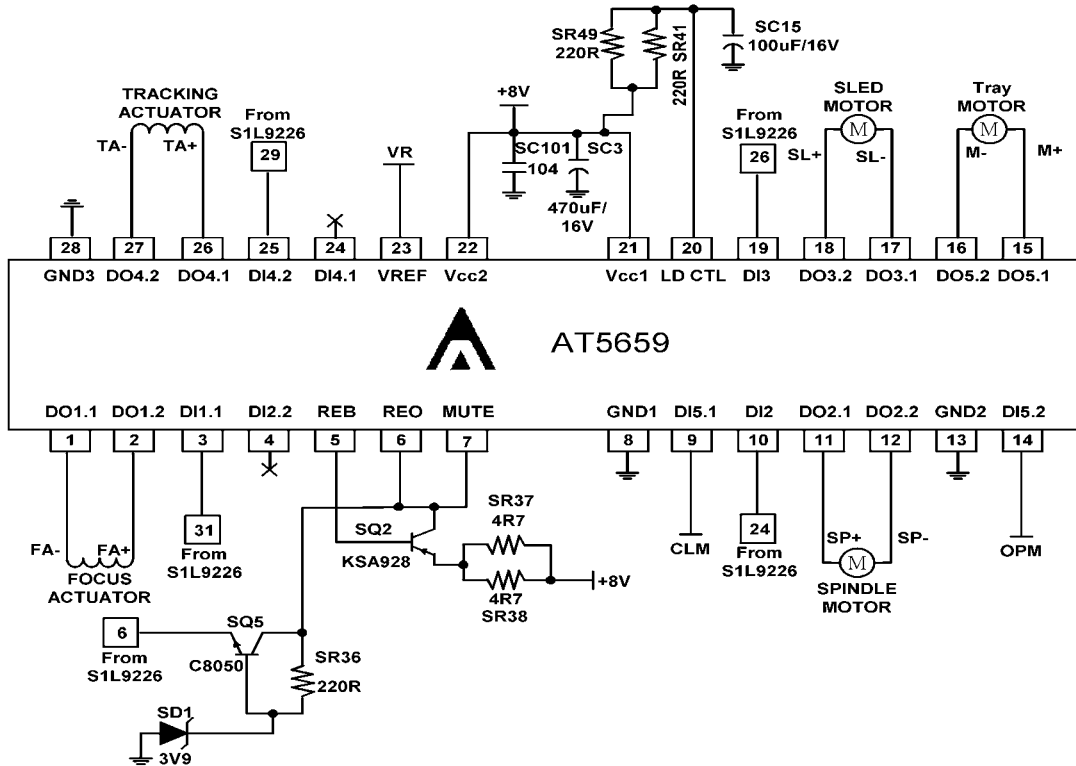

Package Outlines (units:mm): HSOP-28

5-CH MOTOR DRIVER IC

