Features

- Temperature and Voltage Compensated Frequency (Fully Integrated Oscillator)
- Warning Indication of Lamp Failure by Means of Frequency Doubling
- Voltage Dependence of the Indicator Lamps also Compensated for Lamp Failure
- Relay Output with High Current Capability and Low Saturation Voltage
- Frequency Doubling only During Direction Mode
- Temperature Compensated Threshold for Lamp Failure Detection
- Overvoltage and Undervoltage Shut Down of the Relay Outputs
- Quiescent Current $I \leq 10 \mu\text{A}$ (Switches Open)
- EMI Protection According to ISO TR 7637/1, Test Level 4 (Exclusive Load Dump)
- Reversed Battery Protection by Means of a Serial Resistor and Relay Coil Connected
- Load Dump Protection 80V with External Protection Components
- 12V/24V Application
- Package: SO16



Electrostatic sensitive device.

Observe precautions for handling.



1. Description

The integrated circuit ATA6140 is used in relay-controlled automotive flashers. With two output stages, each side of the vehicle is controlled separately. A left and a right direction indicator input with only a small control current makes switch contacts for small loads possible. The separate hazard warning input simplifies the construction of the hazard switch. Lamp outage is indicated by frequency doubling during direction mode. Thanks to the extreme low current consumption the ATA6140 can be connected to the battery directly.



Two-relay Flasher

ATA6140

Rev. 4560E-AUTO-09/05



Figure 1-1. Block Diagram

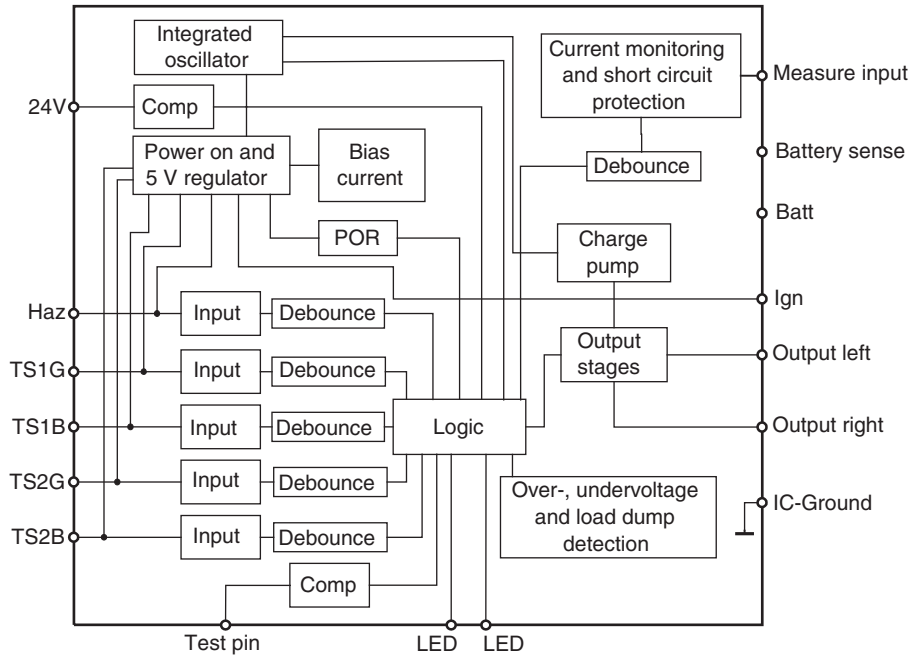

2. Pin Configuration

Figure 2-1. Pinning SO16

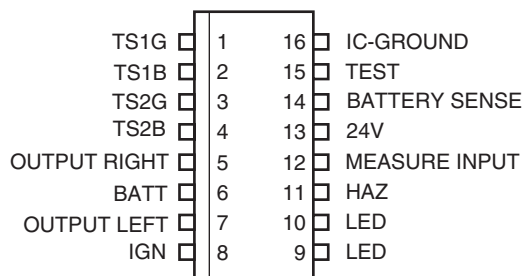

Table 2-1. Pin Description

Pin	Symbol	Direction	Function
1	TS1G	In	Input left turn switch to ground ⁽¹⁾
2	TS1B	In	Input left turn switch to battery ⁽¹⁾
3	TS2G	In	Input right turn switch to ground
4	TS2B	In	Input right turn switch to battery
5	OUTPUT RIGHT	Out	Relay driver right side
6	BATT	Supply	Power battery voltage Battery force
7	OUTPUT LEFT	Out	Relay driver left side
8	IGN	In	Ignition input
9	LED	In	Open: regular frequency Switch to IC-ground: LED outage left side, external signal frequency doubling left side ⁽²⁾
10	LED	In	Open: normal work Switch to IC-ground: LED outage right side, external signal frequency doubling right side ⁽²⁾
11	HAZ	In	Input switch to hazard warning
12	MEASURE INPUT	In	Voltage drop at the shunt resistor
13	24V	In	Switch to 24V version: Open enables overvoltage shut down function, connecting to IC-ground disables overvoltage shut down function
14	BATTERY SENSE	In	Sense battery voltage for the internal comparator with high precision
15	TEST PIN		Either not connected or connected to IC-ground
16	IC-GROUND	Supply	IC-ground

- Note:
1. Use either switches to ground pin 1 and 3 or switches to battery pin 2 and 4
 2. These pins can be connected optional by using LED flashlights to indicate outage. If a LED pin is on low level, frequency doubling is active, independent of pin MEASURE INPUT.

3. Absolute Maximum Ratings

Stresses beyond those listed under “Absolute Maximum Ratings” may cause permanent damage to the device. This is a stress rating only and functional operation of the device at these or any other conditions beyond those indicated in the operational sections of this specification is not implied. Exposure to absolute maximum rating conditions for extended periods may affect device reliability.

Parameters	Symbol	Value	Unit
Supply voltage, pin 6	V_{VS}	6 to 40	V
Ambient temperature range	T_{amb}	-40 to +105	°C
Junction temperature range	T_j	-40 to +150	°C
Storage temperature range	T_{stg}	-55 to +150	°C

4. Thermal Resistance

Parameters	Symbol	Value	Unit
Maximum thermal resistance SO16	R_{thJA}	110	K/W

5. Operating Range

Parameters	Symbol	Value	Unit
Supply voltage, pin 6	V_{VS}	6 to 24	V
Supply voltage, pin 6 (24V version, pin 13 to GND)	V_{VS}	18 to 33	V

6. Noise and Surge Immunity

Parameters	Test Conditions	Value
Conducted interferences ⁽¹⁾	ISO 7637-1	Level 4
ESD (Human Body Model)	MIL-STD-883D Method 3015.7 ⁽²⁾	2 kV
	MIL-STD-883D Method 3015.7 (pin 12 and pin 14)	1 kV
ESD FCDM (Field induced Charge Device Model)	ESD - S. 5.3	500V

- Note:
1. At both outputs a relay of minimum 130 Ω should be added (for details see application circuits [Figure 11-2 on page 8](#) to [Figure 11-9 on page 12](#)).
 2. Exclusive pin 12 and pin 14.

7. Electrical Characteristics

No.	Parameters	Test Conditions	Pin	Symbol	Min.	Typ.	Max.	Unit	Type*
1	Supply Voltage Range								
1.1	Supply voltage		6	V_{VS}	8		16	V	C
1.1	Supply voltage (24V version)		6	V_{VS}	18		33	V	C
2	Current Consumption								
2.1	Quiescent current (V_S)	$V_{VS} < 16V$ switches open	6	I_{VS}			10	μA	A
2.1	Quiescent current (V_S , 24V version)	$V_{VS} < 33V$ switches open	6	I_{VS}			20	μA	A
2.2	Supply current (V_S)	$V_{VS} < 16V$	6	I_{VS}			6	mA	A
2.2	Supply current (V_S , 24V version)	$V_{VS} < 33V$	6	I_{VS}			8	mA	A
3	Under and Overvoltage Detection								
3.1	Undervoltage detection threshold		6	V_{VU}	6		8	V	A
3.2	Undervoltage detection delay time			t_{dUV}	2.5		10	ms	A
3.3	Overvoltage detection threshold		6	V_{VO}	18		22	V	A
3.3	Overvoltage detection threshold (24V version)	Disabled in 24V version (pin 13 to GND)	6	V_{VO}				V	A
4	Relay Outputs								
4.1	Current output right		5	I_{I5}			170	mA	A
4.2	Current output left		7	I_{I7}			170	mA	A
4.3	Saturation voltage right	170 mA at 23°C	5	V_{SATR}			1	V	A
4.4	Saturation voltage left	170 mA at 23°C	7	V_{SATL}			1	V	A
4.5	Leakage current right		5	I_{LEAKR}			3	μA	A
4.5	Leakage current right (24V version)		5	I_{LEAKR}			6	μA	A
4.6	Leakage current left		7	I_{LEAKL}			3	μA	A
4.6	Leakage current left (24V version)		7	I_{LEAKL}			6	μA	A
4.7	Start delay time right		5	T_{DR}	10		40	ms	A
4.8	Start delay time left		7	T_{DL}	10		40	ms	A
5	Control Signal Thresholds								
5.1	Frequency doubling	$V_S = 9V$	12	V_{THFD9}	42	45	48	mV	A
5.2	Frequency doubling	$V_S = 15V$	12	V_{THFD15}	50	53	57	mV	A
5.2	Frequency doubling (24V version)	$V_S = 24V$	12	V_{THFD24}		65		mV	A
5.3	Short circuit detection	$V_S = 13.5V$	12	V_{THSC}	425	475	525	mV	B
5.3	Short circuit detection (24V version)	$V_S = 24V$	12	V_{THSC}		650		mV	B

*) Type means: A = 100% tested, B = 100% correlation tested, C = Characterized on samples, D = Design parameter

7. Electrical Characteristics (Continued)

No.	Parameters	Test Conditions	Pin	Symbol	Min.	Typ.	Max.	Unit	Type*
5.4	Temperature coefficient	-40°C to +105°C	12	C_{TH}		30		$\mu\text{V/K}$	C
5.5	Input current	$V_S = 13.5\text{ V}$	12	I_{TH}			2	μA	A
5.5	Input current (24V version)	$V_S = 24\text{ V}$	12	I_{TH}			4	μA	A
6	LED Inputs								
6.1	Threshold left	$V_S = 13.5\text{ V}$	9	V_{LEDL}	1		4.5	V	A
6.2	Threshold right	$V_S = 13.5\text{ V}$	10	V_{LEDR}	1		4.5	V	A
6.3	Pull-up resistor left		9	R_{LEDL}	10		75	$\text{k}\Omega$	A
6.4	Pull-up resistor right		10	R_{LEDR}	10		75	$\text{k}\Omega$	A
7	Timing								
7.1	Basic frequency	$1/f = 706\text{ ms}$		F_B	-10.5		+12	%	A
7.2	Bright period					50		%	A
7.3	Bright period in failure mode					40		%	A
7.4	Failure frequency			F_F			$2.2 \times F_B$		A
7.5	Debounce time	Bulb outage detection	12		3.6	5	6.2	ms	

*) Type means: A = 100% tested, B = 100% correlation tested, C = Characterized on samples, D = Design parameter

8. Short Circuit or Overload Detection Delay

Direction mode:

100 ms during the first bright phase, 50 ms during all following bright phases

Hazard mode: 100 ms during all bright phases

In case of overload the relay output switches off (not stored)

9. Bulb Outage Detection

The detection of bulb outage takes place during the bright phase. There is a delay time of typically 128 ms before ATA6140 measures the bulb current with a debounce period of 5 ms. After this time the inrush current dropped significantly.

Application hint:

It has to be considered that a slow relay contact may shorten the inrush current decay time and too high current would be measured and falsely an outage may not be detected. If operated with low supply voltage (e.g., 8V) the relay speed could be even slower.

10. Flasher Operating Mode

Ignition	Input Left Ground	Input Right Ground	Input Left Ignition	Input Right Ignition	Input Hazard	Left Lamps ⁽¹⁾	Right Lamps ⁽¹⁾	Frequency in Case of Lamp Failure ⁽¹⁾
Off	Open	Open	IC-ground	IC-ground	Open	x	x	x
Off	Ground	Open	IC-ground	IC-ground	Open	x	x	x
Off	Open	Ground	IC-ground	IC-ground	Open	x	x	x
Off	Open	Open	IC-ground	IC-ground	Ground	Flash	Flash	Normal
Off	Ground	Open	IC-ground	IC-ground	Ground	Flash	Flash	Normal
Off	Open	Ground	IC-ground	IC-ground	Ground	Flash	Flash	Normal
Off	Ground	Ground	IC-ground	IC-ground	Ground	Flash	Flash	Normal
Off	Ground	Ground	IC-ground	IC-ground	Open	x	x	x ⁽²⁾
On	Open	Open	IC-ground	IC-ground	Open	x	x	x
On	Ground	Open	IC-ground	IC-ground	Open	Flash	x	Double
On	Open	Ground	IC-ground	IC-ground	Open	x	Flash	Double
On	Open	Open	IC-ground	IC-ground	Ground	Flash	Flash	Normal
On	Ground	Open	IC-ground	IC-ground	Ground	Flash	Flash	Normal
On	Open	Ground	IC-ground	IC-ground	Ground	Flash	Flash	Normal
On	Ground	Ground	IC-ground	IC-ground	Ground	Flash	Flash	Normal
On	Ground	Ground	IC-ground	IC-ground	Open	Flash	Flash	Normal
Off	V _{BATT}	V _{BATT}	Open	Open	Open	x	x	x
Off	V _{BATT}	V _{BATT}	Ignition	Open	Open	x	x	x
Off	V _{BATT}	V _{BATT}	Open	Ignition	Open	x	x	x
Off	V _{BATT}	V _{BATT}	Open	Open	Ground	Flash	Flash	Normal
Off	V _{BATT}	V _{BATT}	Ignition	Open	Ground	Flash	Flash	Normal
Off	V _{BATT}	V _{BATT}	Open	Ignition	Ground	Flash	Flash	Normal
Off	V _{BATT}	V _{BATT}	Ignition	Ignition	Ground	Flash	Flash	Normal
Off	V _{BATT}	V _{BATT}	Ignition	Ignition	Open	x	x	x ⁽³⁾
On	V _{BATT}	V _{BATT}	Open	Open	Open	x	x	x
On	V _{BATT}	V _{BATT}	Ignition	Open	Open	Flash	x	Double
On	V _{BATT}	V _{BATT}	Open	Ignition	Open	x	Flash	Double
On	V _{BATT}	V _{BATT}	Open	Open	Ground	Flash	Flash	Normal
On	V _{BATT}	V _{BATT}	Ignition	Open	Ground	Flash	Flash	Normal
On	V _{BATT}	V _{BATT}	Open	Ignition	Ground	Flash	Flash	Normal
On	V _{BATT}	V _{BATT}	Ignition	Ignition	Ground	Flash	Flash	Normal
On	V _{BATT}	V _{BATT}	Ignition	Ignition	Open	Flash	Flash	Normal

Notes: 1. x = no flashing

2. If ignition is OFF, the input level cannot be sensed (the IC is in the sleep mode). For hazard mode use the input hazard.

3. For hazard mode use input hazard or switch to battery as shown in [Figure 11-4 on page 9](#) and [Figure 11-8 on page 11](#).

11. Diagrams

Figure 11-1. Timing Diagram

Basic Frequency

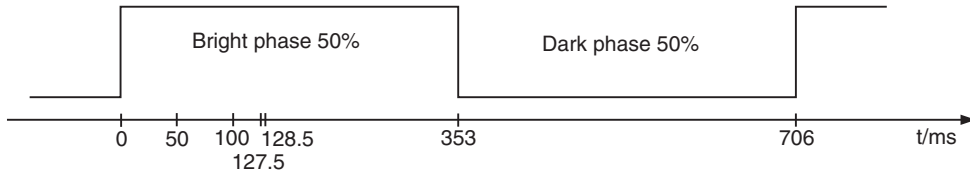

50 ms - 353 ms => short circuit detection
 100 ms - 353 ms => short circuit detection during first bright phase (turn signal mode)
 100 ms - 353 ms => short circuit detection during each bright phase (hazard signal mode)
 127.5 ms - 128.5 ms => lamp outage detection

Doubled Frequency

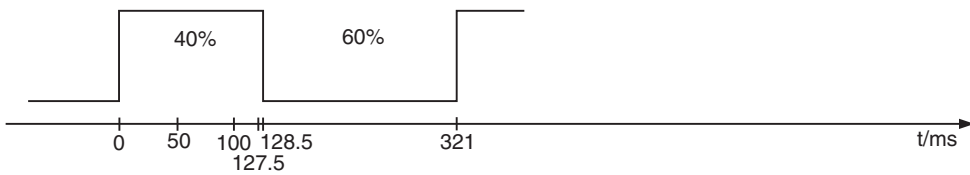

Figure 11-2. Application 1: 12V Version, Turn Signal Switches to GND, Hazard Switch to GND

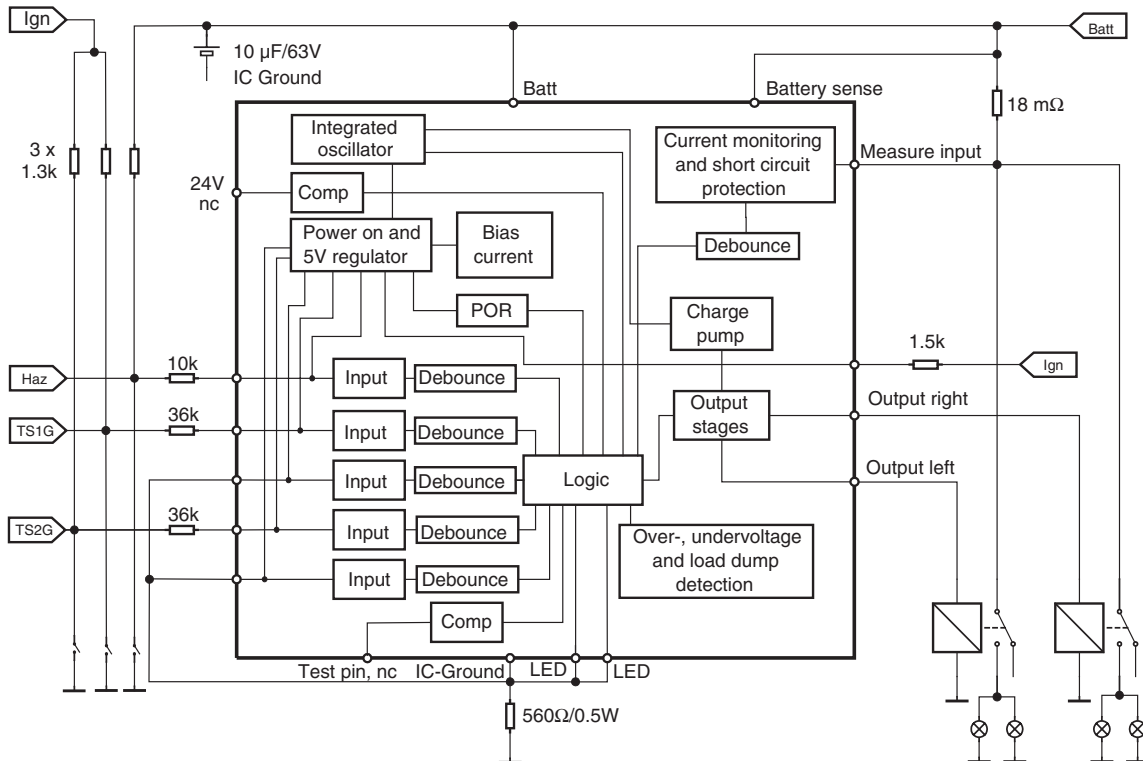

Figure 11-3. Application 2: 12V Version, Turn Signal Switches to Ignition, Hazard Switch to GND

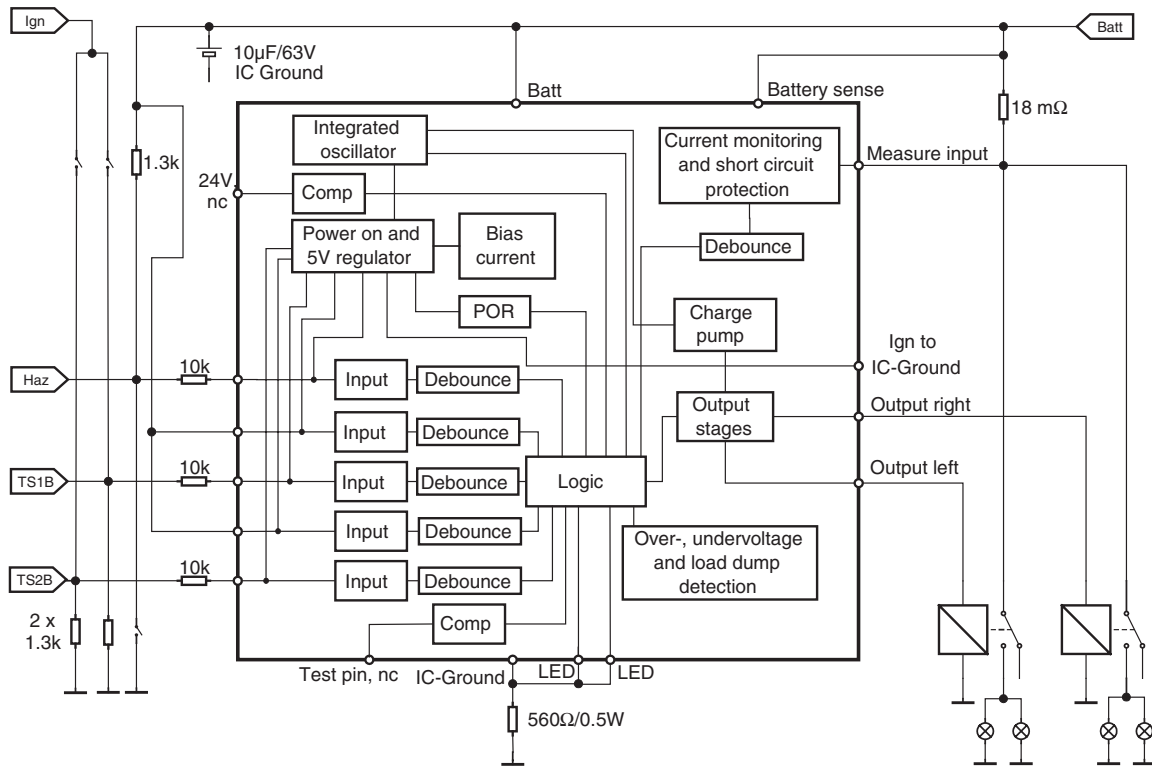

Figure 11-4. Application 3: 12V Version, Turn Signal Switches to Ignition, Hazard Switch to Battery

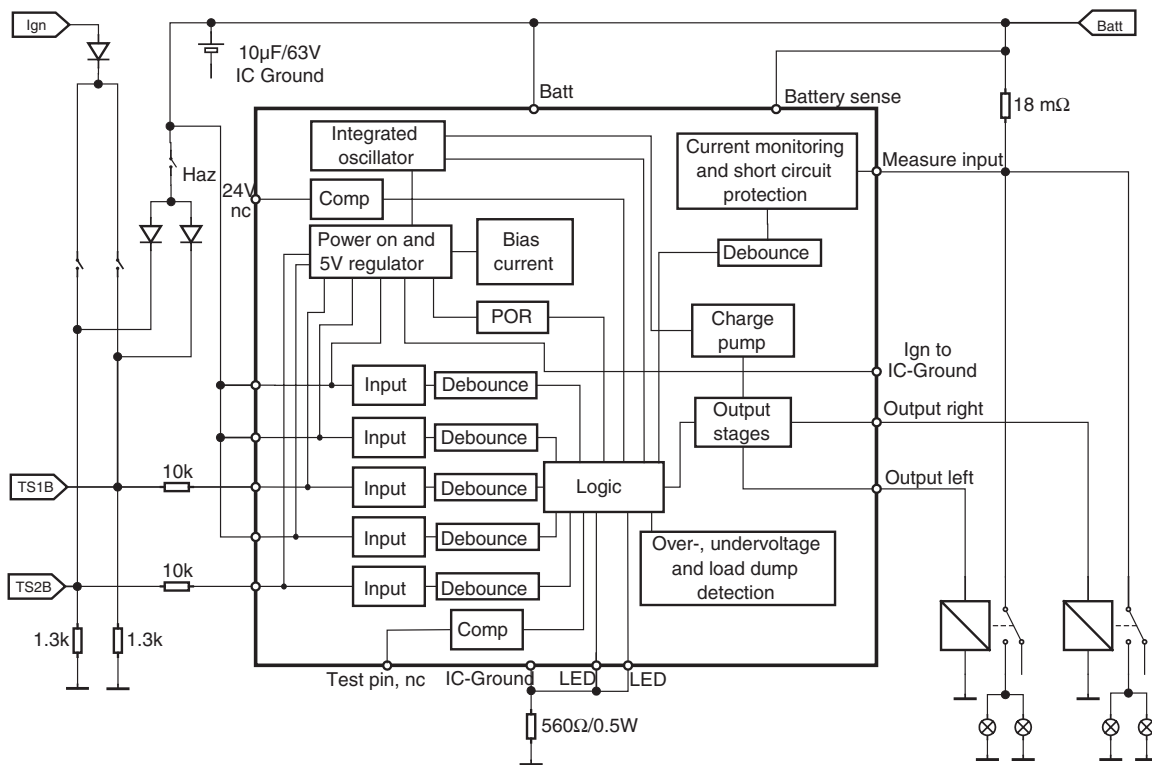

Figure 11-5. Application 4: 12V Version, Turn Signal Switches to Ignition, Hazard Switch to GND, additional LED Outage

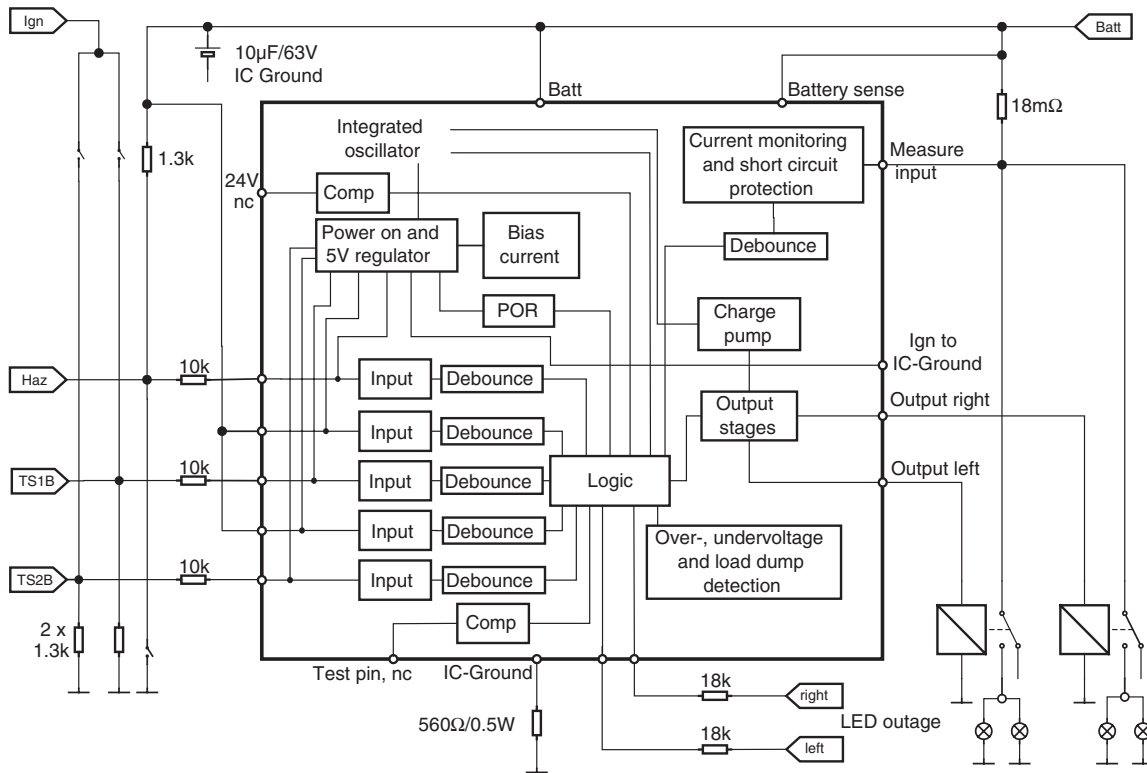

Figure 11-6. Application 1: 24V Version, Turn Signal Switches to GND, Hazard Switch to GND

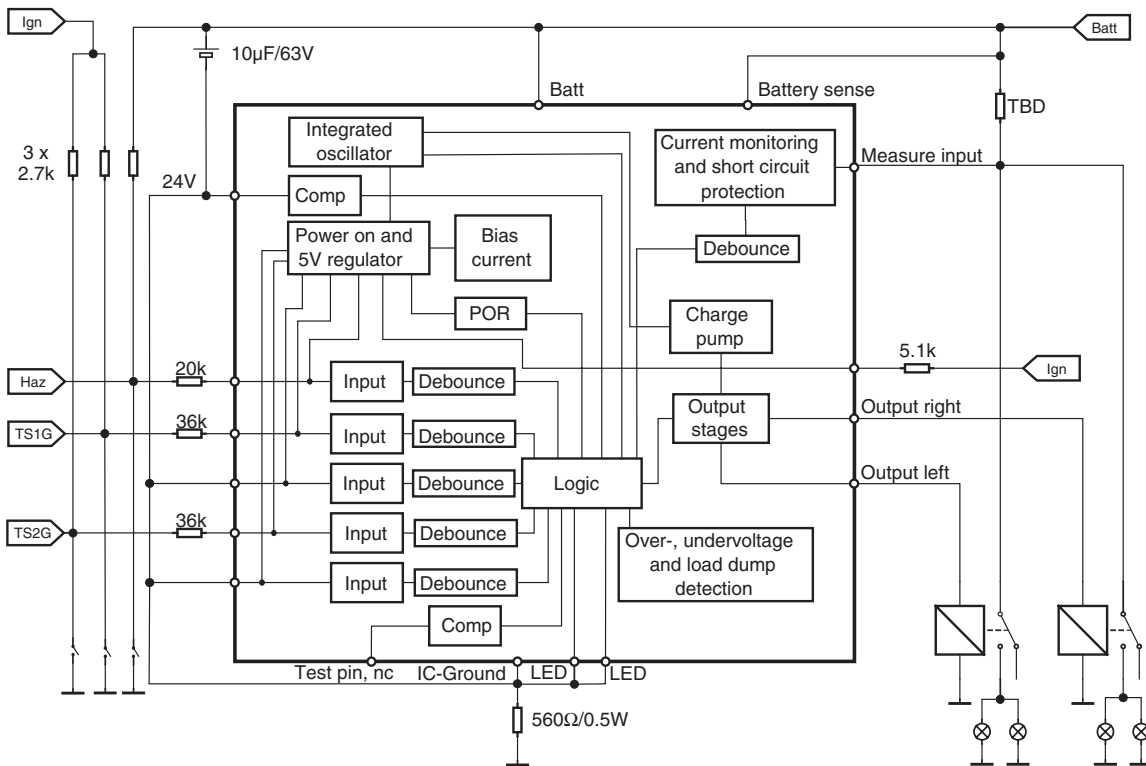

Figure 11-7. Application 2: 24V Version, Turn Signal Switches to Ignition, Hazard Switch to GND

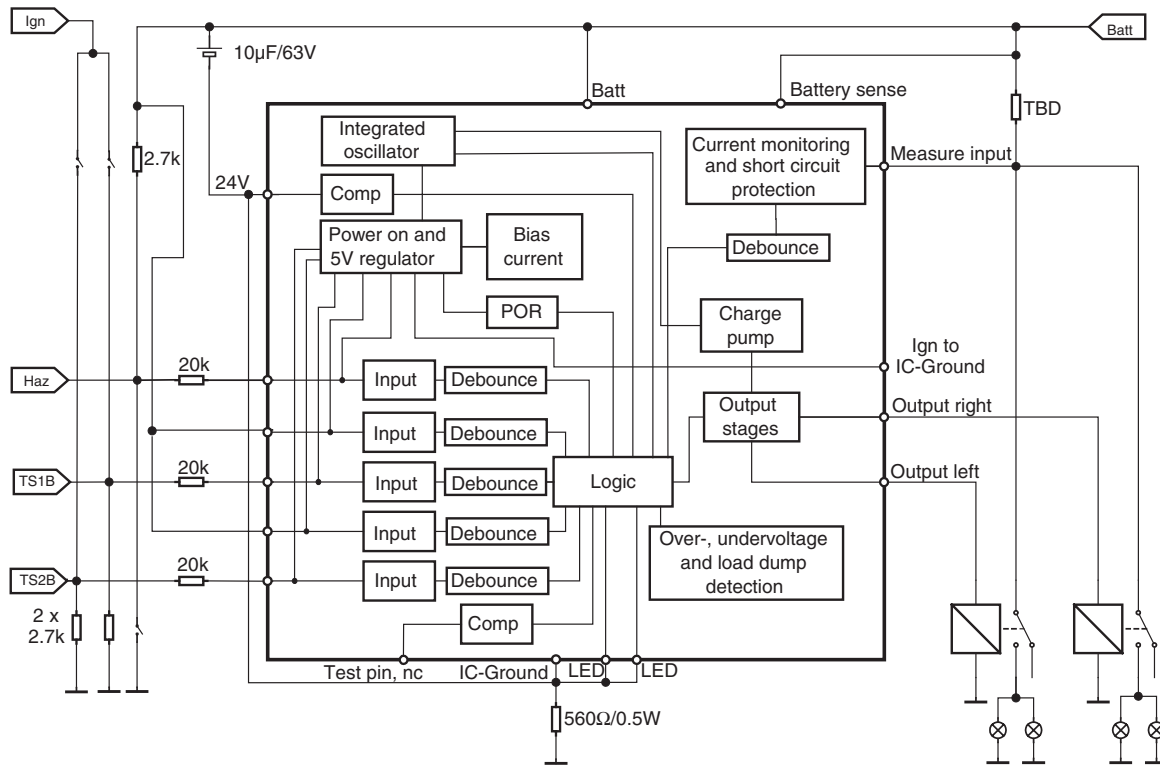

Figure 11-8. Application 3: 24V Version, Turn Signal Switches to Ignition, Hazard Switch to Battery

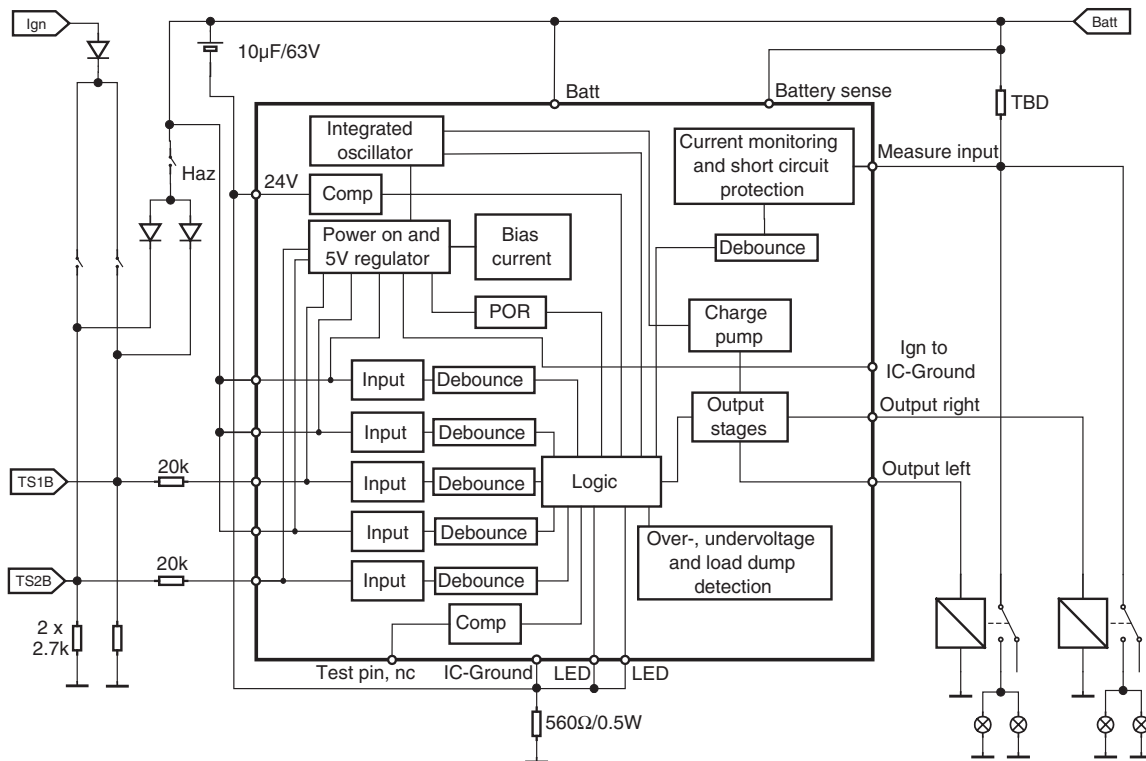
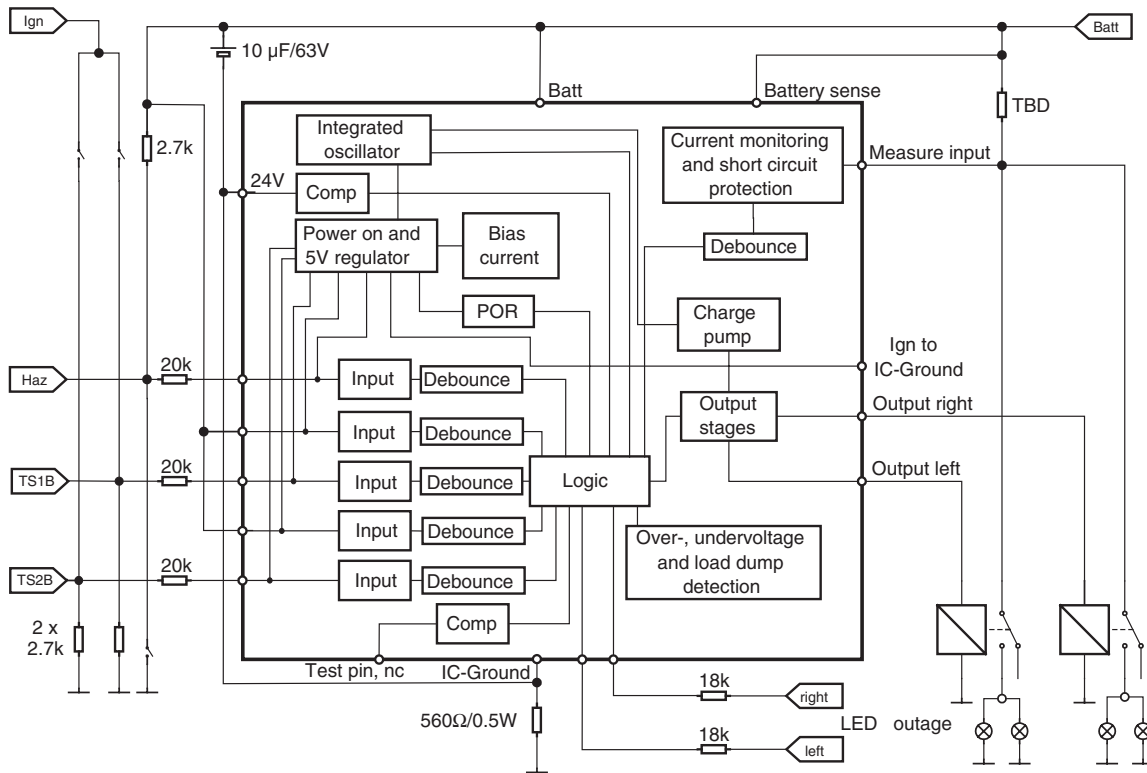

Figure 11-9. Application 4: 24V Version, Turn Signal Switches to Ignition, Hazard Switch to GND, additional LED Outage



12. Ordering Information

Extended Type Number	Package	Remarks
ATA6140-TBQY	SO16	Taped and reeled, Pb-free

13. Package Information

Package SO16
Dimensions in mm

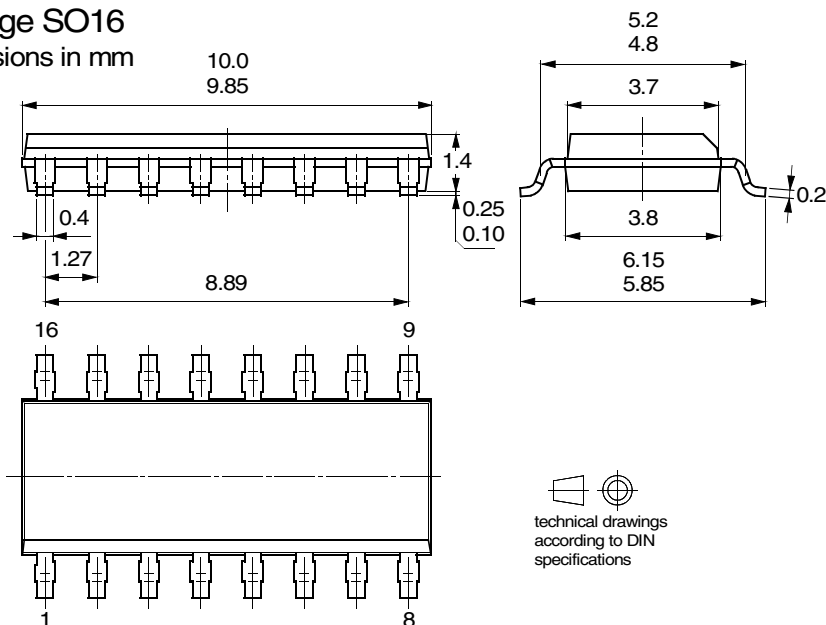

14. Revision History

Please note that the following page numbers referred to in this section refer to the specific revision mentioned, not to this document.

Revision No.	History
4560E-AUTO-09/05	<ul style="list-style-type: none"> Put datasheet in a new template Pb-free logo on page 1 added Ordering Information on page 13 changed



Atmel Corporation

2325 Orchard Parkway
San Jose, CA 95131, USA
Tel: 1(408) 441-0311
Fax: 1(408) 487-2600

Regional Headquarters

Europe

Atmel Sarl
Route des Arsenaux 41
Case Postale 80
CH-1705 Fribourg
Switzerland
Tel: (41) 26-426-5555
Fax: (41) 26-426-5500

Asia

Room 1219
Chinachem Golden Plaza
77 Mody Road Tsimshatsui
East Kowloon
Hong Kong
Tel: (852) 2721-9778
Fax: (852) 2722-1369

Japan

9F, Tonetsu Shinkawa Bldg.
1-24-8 Shinkawa
Chuo-ku, Tokyo 104-0033
Japan
Tel: (81) 3-3523-3551
Fax: (81) 3-3523-7581

Atmel Operations

Memory

2325 Orchard Parkway
San Jose, CA 95131, USA
Tel: 1(408) 441-0311
Fax: 1(408) 436-4314

Microcontrollers

2325 Orchard Parkway
San Jose, CA 95131, USA
Tel: 1(408) 441-0311
Fax: 1(408) 436-4314

La Chantrerie
BP 70602
44306 Nantes Cedex 3, France
Tel: (33) 2-40-18-18-18
Fax: (33) 2-40-18-19-60

ASIC/ASSP/Smart Cards

Zone Industrielle
13106 Rousset Cedex, France
Tel: (33) 4-42-53-60-00
Fax: (33) 4-42-53-60-01

1150 East Cheyenne Mtn. Blvd.
Colorado Springs, CO 80906, USA
Tel: 1(719) 576-3300
Fax: 1(719) 540-1759

Scottish Enterprise Technology Park
Maxwell Building
East Kilbride G75 0QR, Scotland
Tel: (44) 1355-803-000
Fax: (44) 1355-242-743

RF/Automotive

Theresienstrasse 2
Postfach 3535
74025 Heilbronn, Germany
Tel: (49) 71-31-67-0
Fax: (49) 71-31-67-2340

1150 East Cheyenne Mtn. Blvd.
Colorado Springs, CO 80906, USA
Tel: 1(719) 576-3300
Fax: 1(719) 540-1759

Biometrics/Imaging/Hi-Rel MPU/ High Speed Converters/RF Datacom

Avenue de Rochepleine
BP 123
38521 Saint-Egreve Cedex, France
Tel: (33) 4-76-58-30-00
Fax: (33) 4-76-58-34-80

Literature Requests

www.atmel.com/literature

Disclaimer: The information in this document is provided in connection with Atmel products. No license, express or implied, by estoppel or otherwise, to any intellectual property right is granted by this document or in connection with the sale of Atmel products. **EXCEPT AS SET FORTH IN ATMEL'S TERMS AND CONDITIONS OF SALE LOCATED ON ATMEL'S WEB SITE, ATMEL ASSUMES NO LIABILITY WHATSOEVER AND DISCLAIMS ANY EXPRESS, IMPLIED OR STATUTORY WARRANTY RELATING TO ITS PRODUCTS INCLUDING, BUT NOT LIMITED TO, THE IMPLIED WARRANTY OF MERCHANTABILITY, FITNESS FOR A PARTICULAR PURPOSE, OR NON-INFRINGEMENT. IN NO EVENT SHALL ATMEL BE LIABLE FOR ANY DIRECT, INDIRECT, CONSEQUENTIAL, PUNITIVE, SPECIAL OR INCIDENTAL DAMAGES (INCLUDING, WITHOUT LIMITATION, DAMAGES FOR LOSS OF PROFITS, BUSINESS INTERRUPTION, OR LOSS OF INFORMATION) ARISING OUT OF THE USE OR INABILITY TO USE THIS DOCUMENT, EVEN IF ATMEL HAS BEEN ADVISED OF THE POSSIBILITY OF SUCH DAMAGES.** Atmel makes no representations or warranties with respect to the accuracy or completeness of the contents of this document and reserves the right to make changes to specifications and product descriptions at any time without notice. Atmel does not make any commitment to update the information contained herein. Unless specifically provided otherwise, Atmel products are not suitable for, and shall not be used in, automotive applications. Atmel's products are not intended, authorized, or warranted for use as components in applications intended to support or sustain life.

© Atmel Corporation 2005. All rights reserved. Atmel®, logo and combinations thereof, Everywhere You Are® and others, are registered trademarks or trademarks of Atmel Corporation or its subsidiaries. Other terms and product names may be trademarks of others.



Printed on recycled paper.

4560E-AUTO-09/05