



Capacitors for Power Electronics

Series/Type: B253*

The following products presented in this data sheet are being withdrawn.

Ordering Code	Substitute Product	Date of Withdrawal	Deadline Last Orders	Last Shipments
B25355L8367K004	B25650	2001-04-06	2001-07-31	2001-12-31
B25355L7477K004	B25650	2001-04-06	2001-07-31	2001-12-31
B25355L6627K004	B25650	2001-04-06	2001-07-31	2001-12-31
B25355L4887K004	B25650	2001-04-06	2001-07-31	2001-12-31
B25355L2856K004	B25650	2001-04-06	2001-07-31	2001-12-31
B25355L2805K001	B25650	2001-04-06	2001-07-31	2001-12-31
B25355L2635K001	B25650	2001-04-06	2001-07-31	2001-12-31
B25355L2586K004	B25650	2001-04-06	2001-07-31	2001-12-31
B25355L2566K004	B25650	2001-04-06	2001-07-31	2001-12-31
B25355L2466K004	B25650	2001-04-06	2001-07-31	2001-12-31
B25355L2406K001	B25650	2001-04-06	2001-07-31	2001-12-31
B25355L2326K004	B25650	2001-04-06	2001-07-31	2001-12-31
B25355L2316K001	B25650	2001-04-06	2001-07-31	2001-12-31
B25355L2206K001	B25650	2001-04-06	2001-07-31	2001-12-31

Ordering Code	Substitute Product	Date of Withdrawal	Deadline Last Orders	Last Shipments
B25355L2166K001	B25650	2001-04-06	2001-07-31	2001-12-31
B25355L2107K004	B25650	2001-04-06	2001-07-31	2001-12-31
B25355L2106K001	B25650	2001-04-06	2001-07-31	2001-12-31
B25355L1806K004	B25650	2001-04-06	2001-07-31	2001-12-31
B25355L1406K001	B25650	2001-04-06	2001-07-31	2001-12-31
B25355L1316K001	B25650	2001-04-06	2001-07-31	2001-12-31
B25355L1277K004	B25650	2001-04-06	2001-07-31	2001-12-31
B25355L1227K004	B25650	2001-04-06	2001-07-31	2001-12-31
B25355L1206K001	B25650	2001-04-06	2001-07-31	2001-12-31
B25355L1166K001	B25650	2001-04-06	2001-07-31	2001-12-31
B25355L1147K904	B25650	2001-04-06	2001-07-31	2001-12-31
B25355L1147K004	B25650	2001-04-06	2001-07-31	2001-12-31
B25355L1117K004	B25650	2001-04-06	2001-07-31	2001-12-31
B25355L0307K004	B25650	2001-04-06	2001-07-31	2001-12-31
B25355L0167K004	B25650	2001-04-06	2001-07-31	2001-12-31
B25355J3805K001	B25650	2001-04-06	2001-07-31	2001-12-31
B25355J3635K001	B25650	2001-04-06	2001-07-31	2001-12-31
B25355J3504K001	B25650	2001-04-06	2001-07-31	2001-12-31
B25355J3405K001	B25650	2001-04-06	2001-07-31	2001-12-31
B25355J3254K001	B25650	2001-04-06	2001-07-31	2001-12-31
B25355J3205K001	B25650	2001-04-06	2001-07-31	2001-12-31
B25355J3166K001	B25650	2001-04-06	2001-07-31	2001-12-31
B25355J3106K001	B25650	2001-04-06	2001-07-31	2001-12-31
B25355J3105K001	B25650	2001-04-06	2001-07-31	2001-12-31
B25355J2504K001	B25650	2001-04-06	2001-07-31	2001-12-31
B25355J2405K001	B25650	2001-04-06	2001-07-31	2001-12-31
B25355J2205K001	B25650	2001-04-06	2001-07-31	2001-12-31
B25355J2105K001	B25650	2001-04-06	2001-07-31	2001-12-31
B25355J1805K001	B25650	2001-04-06	2001-07-31	2001-12-31
B25355J1635K001	B25650	2001-04-06	2001-07-31	2001-12-31
B25355J1405K001	B25650	2001-04-06	2001-07-31	2001-12-31
B25355J1205K001	B25650	2001-04-06	2001-07-31	2001-12-31
B25355J1106K001	B25650	2001-04-06	2001-07-31	2001-12-31
B25355J1105K001	B25650	2001-04-06	2001-07-31	2001-12-31
B25355G6405K001	B25650	2001-04-06	2001-07-31	2001-12-31
B25355G6205K001	B25650	2001-04-06	2001-07-31	2001-12-31
B25355G2256K001	B25650	2001-04-06	2001-07-31	2001-12-31
B25355C8297K005	B25650	2001-04-06	2001-07-31	2001-12-31
B25355C8197K005	B25650	2001-04-06	2001-07-31	2001-12-31
B25355C7387K005	B25650	2001-04-06	2001-07-31	2001-12-31
B25355C7247K005	B25650	2001-04-06	2001-07-31	2001-12-31

Ordering Code	Substitute Product	Date of Withdrawal	Deadline Last Orders	Last Shipments
B25355C6527K005	B25650	2001-04-06	2001-07-31	2001-12-31
B25355C6337K005	B25650	2001-04-06	2001-07-31	2001-12-31
B25355C4727K005	B25650	2001-04-06	2001-07-31	2001-12-31
B25355C4477K005	B25650	2001-04-06	2001-07-31	2001-12-31

For further information please contact your nearest EPCOS sales office, which will also support you in selecting a suitable substitute. The addresses of our worldwide sales network are presented at www.epcos.com/sales.

High peak-current capability Wide capacitance and voltage range

Construction

- Self-healing
- Paper dielectric
- Oil and hard-wax-impregnated tubular windings (no PCB)
- Metal-sprayed end faces ensure reliable contacting
- Tubular aluminum case
- 1-pole and 2-pole versions
- Ceramic or plastic lead-throughs
- With mounting bolt
(325 mm high capacitors without mounting bolt)



Terminals

- Screw terminals M12
- Screw-clamping terminals
- Tab connectors 6,3 mm

Mounting parts

- If the vibration stress is $\leq 5 g$ and the capacitors are ≤ 60 mm in diameter and ≤ 160 mm in height, the bolt is used for mounting.
- For capacitors without mounting bolt and in case of a vibration stress $> 5 g$ as well as for larger-sized capacitors refer to chapter "Mounting parts".

Grounding

- Mounting bolt or grounding strap for grounding in accordance with VDE 0100
- Grounding identification in accordance with DIN 40 011

Overpressure disconnecter (mechanical)

When the overpressure disconnecter responds, the capacitor extends by up to 8 mm.

So leave sufficient space above the terminals when mounting the capacitor.

Individual data sheets

Individual capacitors of this series are specified in detail (incl. thermal data) [on pages 78 ... 93](#).

Upon request, these data sheets are available for each capacitor type.

B 25 355

Smoothing, Supporting, Discharge

Technical data

Standards		IEC 1071-1/2 EN 61071-1/2 VDE 0560 part 120 and 121	
Dielectric dissipation factor	$\tan \delta_0$	$50 \cdot 10^{-4}$	
Max. repetitive rate of voltage rise	$(du/dt)_{\max}$	$\frac{\hat{i}}{C}$	
Max. non-repetitive rate of voltage rise	$(du/dt)_s$	$\frac{I_s}{C}$	
Climatic data:			
Min. operating temperature	Θ_{\min}	- 40 °C	
Max. operating temperature	Θ_{\max}	+ 70 °C	
Average relative humidity		≤ 95 % (screw terminals, tab connectors) ≤ 75 % (screw-clamping terminals)	
Failure quota	$\alpha_{FQ(\text{co})}$	300 failures per 10^9 component hours	
	$\alpha_{FQ(\text{sto})}$	3000 failures per 10^9 component hours	
Load duration	$t_{LD(\text{co})}$	100 000 h	
	$t_{LD(\text{sto})}$	10 000 h	
Storage temperature limit	Θ_{stg}	- 55/+ 85 °C (screw terminals, tab connectors) - 55/+ 70 °C (screw-clamping terminals)	
IEC climatic category (IEC 68-1 and 2)		40/070/56	
Test A, cold		- 40 °C	
Test B, dry heat		+ 70 °C	
Test Ca, damp heat, steady state		56 days/40 °C/93 % rel. humidity	
Values after test Ca:			
Capacitance change	$\Delta C/C$	≤ 1 %	
		C_N	Screw terminals, tab connectors
Insulation resistance	R_{is}	≤ 1 μF	≥ 5000 MΩ
			Screw-clamping terminals
Self-discharge time constant $\tau =$	$R_{\text{is}} \cdot C$	> 1 μF	≥ 5000 s
			≥ 1000 s
Dissipation factor change	$\Delta \tan \delta$	≤ $10 \cdot 10^{-4}$	

Technical data

Test data:			
DC test voltage between terminals	U_{TT}	$1,5 \cdot U_{N(cc)}, 10 \text{ s}$	
AC test voltage between terminals and case	U_{TC}	$2 \cdot U_i + 1000 \text{ V}, 50 \text{ Hz}, 10 \text{ s}$	
		C_N	Screw terminals, tab connectors
			Screw-clamping terminals
Insulation resistance	R_{is}	$\leq 1 \mu\text{F}$	$\geq 5000 \text{ M}\Omega$
Self-discharge time constant $\tau =$	$R_{is} \cdot C$	$> 1 \mu\text{F}$	$\geq 5000 \text{ s}$
Dissipation factor	$\tan \delta$	$\leq 10 \mu\text{F}: \leq 100 \cdot 10^{-4}$, measuring frequency 1 kHz	
		$> 10 \mu\text{F}: < 70 \cdot 10^{-4}$, measuring frequency 120 Hz	

B 25 355

Smoothing, Supporting, Discharge

Available ratings

$U_{N(co)}$ (V) DC	450	600	750	850	1200	1400	1600
$U_{N(sto)}$ (V) DC	560	750	940	1100	1500	1800	2000
C_R (μ F)							
0,5							
1,0							
2,0							
4,0							
6,3							
8,0							
10							
16							
20							
31,5							
40							
110							
140							
160							
190							
220							
245							
270							
290							
300							
330							
360							
380							
400							
430							
470							
520							
620							
720							
880							

 Data book range

 Upon request

Available ratings

$U_{N(co)}$ (V) DC	1800	2000	2400	2800	3200	6300	
$U_{N(sto)}$ (V) DC	2300	2500	3000	3500	4000	7900	
C_R (μ F)							
0,25							
0,5							
1,0							
2,0							
4,0							
6,3							
8,0							
10							
16							
20							
25							
31,5							
32							
40							
46							
56							
58							
80							
85							
105							
145							

Data book range

Upon request

B 25 355

Smoothing, Supporting, Discharge

Characteristics and ordering codes

$C_N^{(1)}$	I_{max}	\hat{i}	I_s	R_S 20 °C	L_{self}	Dimensions $d \times l$	Fig.	Appr. weight	Ordering code	Pg.
μF	A	A	A	m Ω	nH	mm		g		
$U_{N(co)} = DC \ 450 \ V$				$U_{N(sto)} = DC$		560 V	$\hat{u} =$	560 V	$U_{TT} = DC \ 680 \ V, \ 10 \ s$	
				$U_i = AC$		400 V	$u_s =$	680 V	$U_{TC} = AC \ 2000 \ V, \ 10 \ s$	
470	40	26000	31000	2,8	240	99,3 × 248	3	2300	B25355-C4477-K005	
720	40	32000	36000	2,6	240	121,6 × 248	3	3500	B25355-C4727-K005	
880	100	40000	48000	1,4	200	121,6 × 325	2a	4500	B25355-L4887-K004	
$U_{N(co)} = DC \ 600 \ V$				$U_{N(sto)} = DC$		750 V	$\hat{u} =$	750 V	$U_{TT} = DC \ 900 \ V, \ 10 \ s$	
				$U_i = AC$		530 V	$u_s =$	900 V	$U_{TC} = AC \ 2100 \ V, \ 10 \ s$	
330	40	23000	33000	2,9	240	99,3 × 248	3	2300	B25355-C6337-K005	78
520	40	36000	42000	2,6	240	121,6 × 248	3	3500	B25355-C6527-K005	
620	100	43000	50000	1,5	200	121,6 × 325	2a	4500	B25355-L6627-K004	
$U_{N(co)} = DC \ 750 \ V$				$U_{N(sto)} = DC$		940 V	$\hat{u} =$	940 V	$U_{TT} = DC \ 1150 \ V, \ 10 \ s$	
				$U_i = AC$		670 V	$u_s =$	1100 V	$U_{TC} = AC \ 2400 \ V, \ 10 \ s$	
245	40	19000	34000	3,0	240	99,3 × 248	3	2300	B25355-C7247-K005	
380	40	30000	42000	2,7	240	121,6 × 248	3	3500	B25355-C7387-K005	
470	100	38000	52000	1,6	200	121,6 × 325	2a	4500	B25355-L7477-K004	80
$U_{N(co)} = DC \ 850 \ V$				$U_{N(sto)} = DC$		1100 V	$\hat{u} =$	1100 V	$U_{TT} = DC \ 1300 \ V, \ 10 \ s$	
				$U_i = AC$		780 V	$u_s =$	1300 V	$U_{TC} = AC \ 2600 \ V, \ 10 \ s$	
190	40	17000	36000	3,1	240	99,3 × 248	3	2300	B25355-C8197-K005	
290	40	26000	44000	2,8	240	121,6 × 248	3	3500	B25355-C8297-K005	
360	100	32000	54000	1,7	200	121,6 × 325	2a	4500	B25355-L8367-K004	
$U_{N(co)} = DC \ 1200 \ V$				$U_{N(sto)} = DC$		1500 V	$\hat{u} =$	1500 V	$U_{TT} = DC \ 1800 \ V, \ 10 \ s$	
				$U_i = AC$		1100 V	$u_s =$	1800 V	$U_{TC} = AC \ 3200 \ V, \ 10 \ s$	
160	80	16000	40000	3,0	180	121,6 × 176	1a	2500	B25355-L0167-K004	
300	100	40000	75000	1,9	200	121,6 × 325	2a	4500	B25355-L0307-K004	82
$U_{N(co)} = DC \ 1400 \ V$				$U_{N(sto)} = DC$		1800 V	$\hat{u} =$	1800 V	$U_{TT} = DC \ 2100 \ V, \ 10 \ s$	
				$U_i = AC$		1300 V	$u_s =$	2100 V	$U_{TC} = AC \ 3600 \ V, \ 10 \ s$	
140	80	14000	35000	3,0	180	121,6 × 176	1a	2500	B25355-L1147-K004	
270	100	27000	67000	1,9	210	121,6 × 325	2a	4500	B25355-L1277-K004	

1) Capacitance tolerance $\pm 10 \%$

Characteristics and ordering codes

$C_N^{1)}$ μF	I_{max} A	\hat{i} A	I_s A	R_S 20 °C mΩ	L_{self} nH	Dimensions $d \times l$ mm	Fig.	Appr. weight g	Ordering code	Pg.
$U_{N(\text{co})} = \text{DC } 1600 \text{ V}$				$U_{N(\text{sto})} = \text{DC } 2000 \text{ V}$ $U_i = \text{AC } 1450 \text{ V}$		$\hat{u} = 2000 \text{ V}$ $u_s = 2400 \text{ V}$		$U_{\text{TT}} = \text{DC } 2400 \text{ V, } 10 \text{ s}$ $U_{\text{TC}} = \text{AC } 3900 \text{ V, } 10 \text{ s}$		
1	16	700	1700	17,0	70	35,0 × 57	4	70	B25355-J1105-K001	84
2	16	400	1000	38,0	110	35,0 × 86	4	100	B25355-J1205-K001	
4	16	800	2000	22,0	110	35,0 × 86	4	100	B25355-J1405-K001	
6,3	16	1200	3100	16,0	110	40,0 × 86	4	130	B25355-J1635-K001	
8	16	1600	4000	14,0	110	45,0 × 86	4	160	B25355-J1805-K001	
10	16	2000	5000	12,0	110	50,0 × 86	4	200	B25355-J1106-K001	
16	20	3200	8000	5,7	110	79,2 × 104	5	600	B25355-L1166-K001	
20	20	4000	10000	4,7	110	79,2 × 104	5	600	B25355-L1206-K001	
31,5	20	6300	15000	3,7	110	99,3 × 104	5	950	B25355-L1316-K001	
40	20	4000	10000	8,3	180	79,2 × 176	5	1000	B25355-L1406-K001	
110	80	11000	27000	3,5	180	121,6 × 176	1a	2500	B25355-L1117-K004	
220	100	22000	55000	2,0	210	121,6 × 325	2a	4500	B25355-L1227-K004	
$U_{N(\text{co})} = \text{DC } 1800 \text{ V}$				$U_{N(\text{sto})} = \text{DC } 2300 \text{ V}$ $U_i = \text{AC } 1700 \text{ V}$		$\hat{u} = 2300 \text{ V}$ $u_s = 2700 \text{ V}$		$U_{\text{TT}} = \text{DC } 2700 \text{ V, } 10 \text{ s}$ $U_{\text{TC}} = \text{AC } 4400 \text{ V, } 10 \text{ s}$		
80	80	11000	28000	3,9	190	121,6 × 176	1a	2500	B25355-L1806-K004	
145	100	20000	51000	2,3	210	121,6 × 325	2a	4500	B25355-L1147-K904	
$U_{N(\text{co})} = \text{DC } 2000 \text{ V}$				$U_{N(\text{sto})} = \text{DC } 2500 \text{ V}$ $U_i = \text{AC } 1800 \text{ V}$		$\hat{u} = 2500 \text{ V}$ $u_s = 3000 \text{ V}$		$U_{\text{TT}} = \text{DC } 3000 \text{ V, } 10 \text{ s}$ $U_{\text{TC}} = \text{AC } 4600 \text{ V, } 10 \text{ s}$		
0,5	16	450	1100	22,0	70	35,0 × 57	4	70	B25355-J2504-K001	
1	16	900	2200	14,0	70	40,0 × 57	4	90	B25355-J2105-K001	
2	16	600	1500	28,0	110	35,0 × 86	4	100	B25355-J2205-K001	
4	16	1200	3000	17,0	110	45,0 × 86	4	160	B25355-J2405-K001	
6,3	20	1800	4700	8,7	110	64,2 × 104	5	400	B25355-L2635-K001	
8	20	2400	6000	7,3	110	79,2 × 104	5	600	B25355-L2805-K001	
10	20	3000	7500	6,0	110	79,2 × 104	5	600	B25355-L2106-K001	
16	20	4800	12000	4,3	110	89,3 × 104	5	800	B25355-L2166-K001	
20	20	6000	15000	3,8	110	99,3 × 104	5	950	B25355-L2206-K001	
31,5	20	3100	7800	8,0	180	89,3 × 176	5	1300	B25355-L2316-K001	
40	20	4000	10000	6,6	180	99,3 × 176	5	1600	B25355-L2406-K001	
58	80	10000	25000	4,4	190	121,6 × 176	1b	2500	B25355-L2586-K004	
105	100	18000	45000	2,6	230	121,6 × 325	2b	4500	B25355-L2107-K004	

1) Capacitance tolerance $\pm 10 \%$

B 25 355

Smoothing, Supporting, Discharge

Characteristics and ordering codes

$C_N^{1)}$	I_{max}	\hat{i}	I_s	R_S 20 °C	L_{self}	Dimensions $d \times l$	Fig.	Appr. weight	Ordering code	Pg.
μF	A	A	A	m Ω	nH	mm		g		
$U_{N(co)} = DC 2400 V$				$U_{N(sto)} = DC 3000 V$		$\hat{u} = 3000 V$		$U_{TT} = DC 3600 V, 10 s$		
				$U_i = AC 2200 V$		$u_s = 3600 V$		$U_{TC} = AC 5400 V, 10 s$		
46	80	9000	22000	4,7	200	121,6 × 176	1b	2500	B25355-L2466-K004	
85	100	16000	40000	2,7	230	121,6 × 325	2b	4500	B25355-L2856-K004	
$U_{N(co)} = DC 2800 V$				$U_{N(sto)} = DC 3500 V$		$\hat{u} = 3500 V$		$U_{TT} = DC 4200 V, 10 s$		
				$U_i = AC 2500 V$		$u_s = 4200 V$		$U_{TC} = AC 6000 V, 10 s$		
25 ²⁾	20	5000	12000	8,0	180	99,3 × 176	6	1600	B25355-G2256-K001	
32	60	7000	18000	5,4	220	121,6 × 176	1b	2500	B25355-L2326-K004	88
56	100	12000	31000	3,2	250	121,6 × 325	2b	4500	B25355-L2566-K004	
$U_{N(co)} = DC 3200 V$				$U_{N(sto)} = DC 4000 V$		$\hat{u} = 4000 V$		$U_{TT} = DC 4800 V, 10 s$		
				$U_i = AC 2900 V$		$u_s = 4800 V$		$U_{TC} = AC 6800 V, 10 s$		
0,25	16	250	600	27,0	70	35,0 × 57	4	70	B25355-J3254-K001	
0,5	16	500	1200	16,0	70	40,0 × 57	4	90	B25355-J3504-K001	90
1	16	500	1200	35,0	110	40,0 × 86	4	130	B25355-J3105-K001	
2	16	1000	2400	20,0	110	50,0 × 86	4	200	B25355-J3205-K001	
4	20	2000	4800	8,7	110	79,2 × 104	5	600	B25355-L3405-K001	
6,3	20	3100	7500	6,0	110	89,3 × 104	5	800	B25355-L3635-K001	
8	20	4000	9600	5,1	110	99,3 × 104	5	950	B25355-L3805-K001	
10	20	5000	12000	7,8	180	79,2 × 176	5	1000	B25355-L3106-K001	
16	20	8000	19000	5,6	180	99,3 × 176	5	1600	B25355-L3166-K001	
$U_{N(co)} = DC 6300 V$				$U_{N(sto)} = DC 7900 V$		$\hat{u} = 7900 V$		$U_{TT} = DC 9500 V, 10 s$		
						$u_s = 9500 V$				
2 ²⁾	20	2000	5000	18,0	180	79,2 × 176	6	1000	B25355-G6205-K001	
4 ²⁾	20	4000	10000	10,0	180	99,3 × 176	6	1600	B25355-G6405-K001	92

1) Capacitance tolerance $\pm 10\%$

2) 1-pole capacitor.

No insulated voltage and test voltage between terminal/case needed.

Dimensional drawing 1a/1b
 Screw terminals M12
 Type with mounting bolt

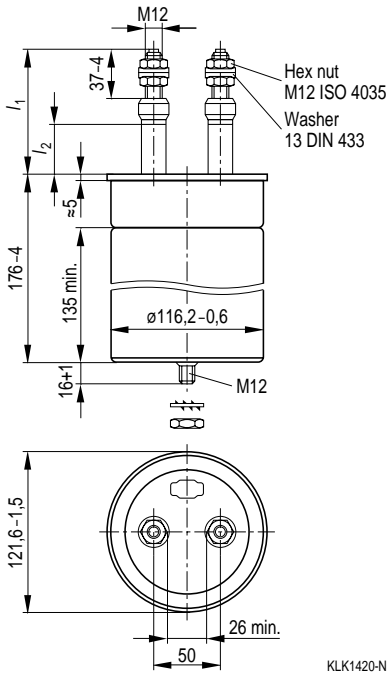

KLK1420-N

Dimensional drawing 2a/2b
 Screw terminals M12
 Type without mounting bolt

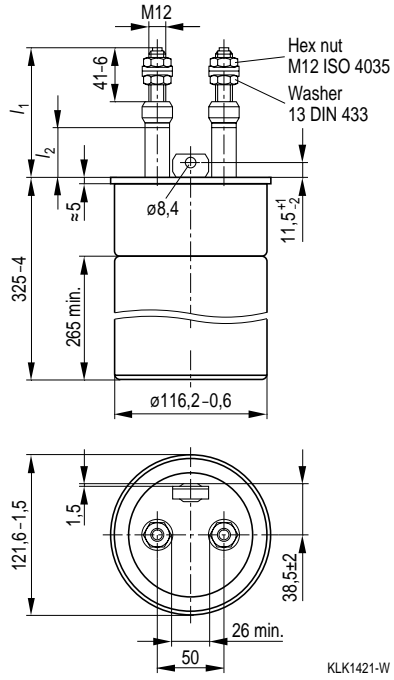

KLK1421-W

Dimensions in mm

Fig.	1a	1b
l_1	72 –6	90 –6
l_2	18 min.	36 min.
Creepage distance	18 mm	36 mm
Clearance	18 mm	26 mm
Max. torque terminals*)	10 Nm	10 Nm

Dimensions in mm

Fig.	2a	2b
l_1	76 –8	94 –8
l_2	18 min.	36 min.
Creepage distance	18 mm	36 mm
Clearance	18 mm	26 mm
Max. torque terminals*)	10 Nm	10 Nm

*) The terminal torque must not act upon the ceramic. So the lead should be locked between two nuts.

Mounting parts (included in delivery)

Threaded bolt	Max. torque	Toothed washer	Hex nut
M12	10 Nm	J 12,5 DIN 6797	M12 ISO 4035

B 25 355

Smoothing, Supporting, Discharge

Dimensional drawing 3
Screw-clamping terminals

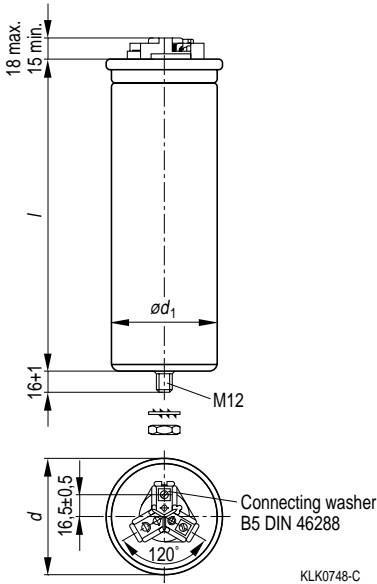

Dimensional drawing 4
Tab connectors 6,3 mm

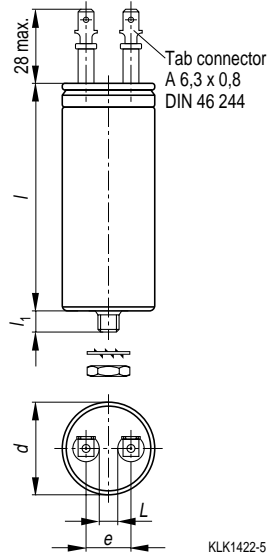

Dimensions in mm

d	$l-4$	$\varnothing d_1$	Creepage distance	Clearance
99,3 -1,2	248	95,2-0,4	12,7	9,6
121,6 -1,5	248	116,2-0,6	12,7	9,6

Dimensions in mm

$d^{+0,5}_{-0,2}$	l^{+1}_{-2}	$l_1 + 1^*)$	$e \pm 1$	Creepage distance	Clearance L
35	57	8	17	10	5,7
35	86	8	17	10	5,7
40	57	8	21	10	9
40	86	8	21	10	9
45	86	8	21	10	9
50	86	12	21	10	9

*) 8 mm = threaded bolt M8
12 mm = threaded bolt M12

Mounting parts (included in delivery)

Threaded bolt	Max. torque	Toothed washer	Hex nut
M8	4 Nm	J 8,2 DIN 6797	M8 ISO 4035
M12	10 Nm	J 12,5 DIN 6797	M12 ISO 4035 (plastic nut upon request)

Dimensional drawing 5

Tab connectors 6,3 mm

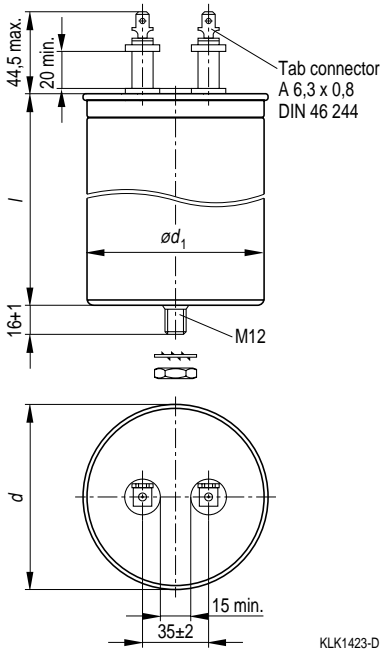

Dimensional drawing 6

Tab connectors 6,3 mm

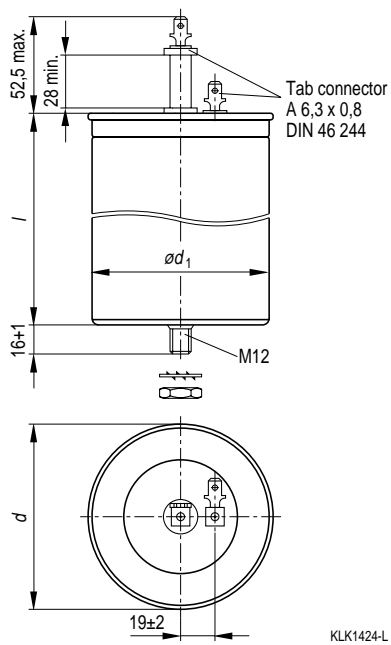

Dimensions in mm

$d-1,2$	$l-4$	$\varnothing d_1-0,4$	Creepage distance	Clearance
64,2	104	60,2	20	15
79,2	104	75,2		
79,2	176	75,2		
89,3	104	85,2		
89,3	176	85,2		
99,3	104	95,2		
99,3	176	95,2		

Dimensions in mm

$d-1,2$	$l-4$	$\varnothing d_1-0,4$	Creepage distance	Clearance
79,2	176	75,2	28	26
99,3	176	95,2	28	26

Mounting parts (included in delivery)

Threaded bolt	Max. torque	Toothed washer	Hex nut
M12	10 Nm	J 12,5 DIN 6797	M12 ISO 4035

B 25 355

Smoothing, Supporting, Discharge

330 μ F / 600 Vdc

Ordering code: B25355-C6337-K005

Characteristics

C_N , tol.	330 μ F \pm 10 %
$U_{N(co)}$	DC 600 V
$U_{N(sto)}$	DC 750 V
U_i	AC 530 V
W_N	60 Ws
I_{max}	40 A
L_{self}	240 nH
$\tan \delta_0$	$50 \cdot 10^{-4}$
R_S	2,9 m Ω

Maximum ratings

\hat{u}	750 V
u_s	900 V
\hat{i}	23 kA
I_s	33 kA
$(du/dt)_{max}$	70 V/ μ s
$(du/dt)_s$	100 V/ μ s

Test data

U_{TT}	DC 900 V, 10 s
U_{TC}	AC 2100 V, 10 s
$R_{is} \cdot C$	≥ 3000 s
$\tan \delta$ (120 Hz)	$\leq 62 \cdot 10^{-4}$

Climatic data

Θ_{min}	- 40 $^{\circ}$ C
Θ_{max}	+ 70 $^{\circ}$ C
Humidity	Average relative humidity ≤ 75 %
$\alpha_{FQ(co)}$	300/10 ⁹ h
$\alpha_{FQ(sto)}$	3000/10 ⁹ h
$t_{LD(co)}$	100000 h
$t_{LD(sto)}$	10000 h
Θ_{stg}	- 55 to + 70 $^{\circ}$ C

IEC climatic category: 40/070/56

(IEC 68-1 and 2)

Θ_{test}	+ 40 $^{\circ}$ C
Rel. humidity	93 %
t_{test}	56 days
$\Delta C/C$	≤ 1 %
$\Delta \tan \delta$	$\leq 10 \cdot 10^{-4}$
$R_{is} \cdot C$	≥ 1000 s

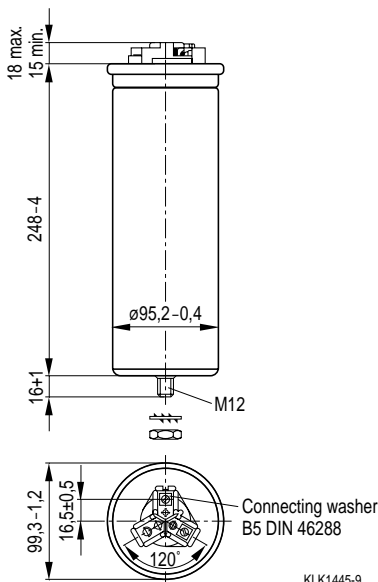

KLK1445-9

Design data

Dimensions $\varnothing \times l$	99,3 mm \times 248 mm
Approx. weight	2300 g
Impregnation	Oil
Fixing	Threaded bolt M12
Mounting hole	14 mm
Max. torque	10 Nm
Terminals	Screw clamps
Terminal cross section	6,0 mm ²
Creepage distance	12,7 mm
Clearance	9,6 mm
Overpressure disconnecter	

Thermal data

B25355-C6337-K005

Dielectric power dissipation P_D
versus repetition frequency f_0

$\hat{u}_{ac} = 60 \text{ V}$ —————
 $\hat{u}_{ac} = 54 \text{ V}$ - - - - -

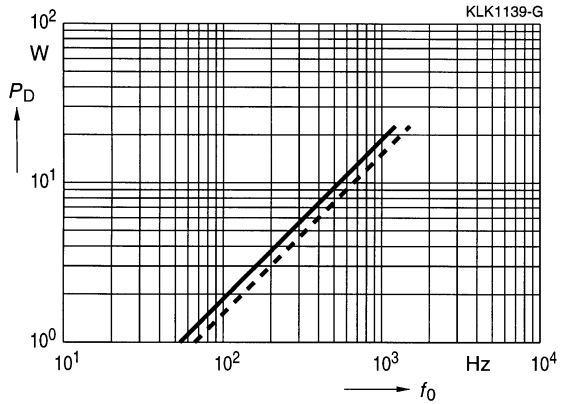

Ohmic power dissipation P_R
versus rms current value I

$R_S (70 \text{ }^\circ\text{C}) = 3,6 \text{ m}\Omega$

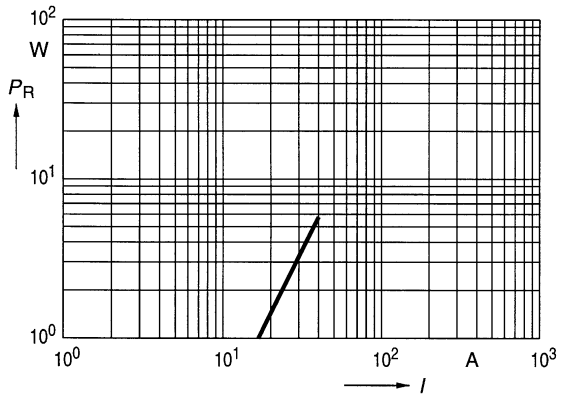

Permissible ambient temperature Θ_A
versus total power dissipation P
(Upright mounting position)

Natural cooling —————
Forced cooling 2 m/s - - - - -
Permissible capacitor
temperature - · - · - ·

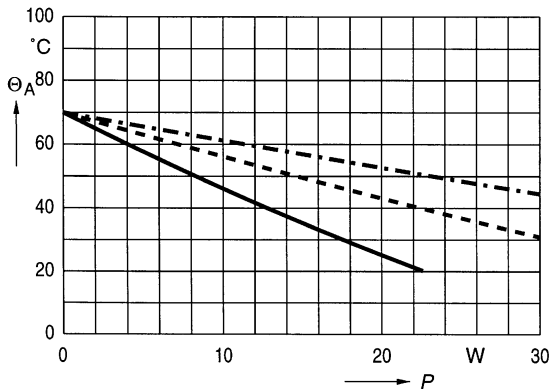

B 25 355

Smoothing, Supporting, Discharge

470 μ F / 750 Vdc

Ordering code: B25355-L7477-K004

Characteristics

C_N , tol.	470 μ F \pm 10 %
$U_{N(co)}$	DC 750 V
$U_{N(sto)}$	DC 940 V
U_i	AC 670 V
W_N	130 Ws
I_{max}	100 A
L_{self}	200 nH
$\tan \delta_0$	$50 \cdot 10^{-4}$
R_S	1,6 m Ω

Maximum ratings

\hat{u}	940 V
u_s	1100 V
\hat{i}	38 kA
I_s	52 kA
$(du/dt)_{max}$	80 V/ μ s
$(du/dt)_s$	110 V/ μ s

Test data

U_{TT}	DC 1150 V, 10 s
U_{TC}	AC 2400 V, 10 s
$R_{is} \cdot C$	≥ 5000 s
$\tan \delta$ (120 Hz)	$\leq 60 \cdot 10^{-4}$

Climatic data

Θ_{min}	- 40 °C
Θ_{max}	+ 70 °C
Humidity	Average relative humidity ≤ 95 %
$\alpha_{FQ(co)}$	$300/10^9$ h
$\alpha_{FQ(sto)}$	$3000/10^9$ h
$t_{LD(co)}$	100000 h
$t_{LD(sto)}$	10000 h
Θ_{stg}	- 55 to + 85 °C

IEC climatic category: 40/070/56

(IEC 68-1 and 2)

Θ_{test}	+ 40 °C
Rel. humidity	93 %
t_{test}	56 days
$\Delta C/C$	≤ 1 %
$\Delta \tan \delta$	$\leq 10 \cdot 10^{-4}$
$R_{is} \cdot C$	≥ 5000 s

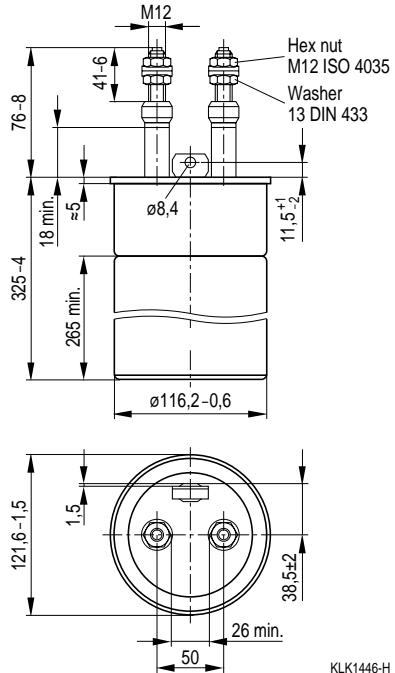

Design data

Dimensions $\varnothing \times l$	121,6 mm \times 325 mm
Approx. weight	4500 g
Impregnation	Oil
Terminals	Screw terminals M12
Max. torque	10 Nm
Terminal cross section	16 mm ²
Creepage distance	18 mm
Clearance	18 mm
Overpressure disconnecter	

Thermal data

B25355-L7477-K004

Dielectric power dissipation P_D
versus repetition frequency f_0

$\hat{u}_{ac} = 75 \text{ V}$ —————
 $\hat{u}_{ac} = 68 \text{ V}$ - - - - -

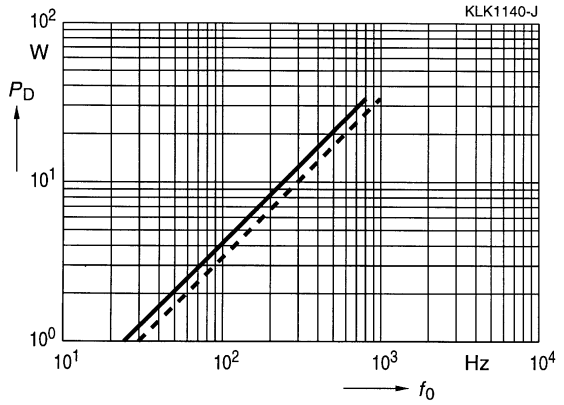

Ohmic power dissipation P_R
versus rms current value I

$R_S (70 \text{ }^\circ\text{C}) = 1,9 \text{ m}\Omega$

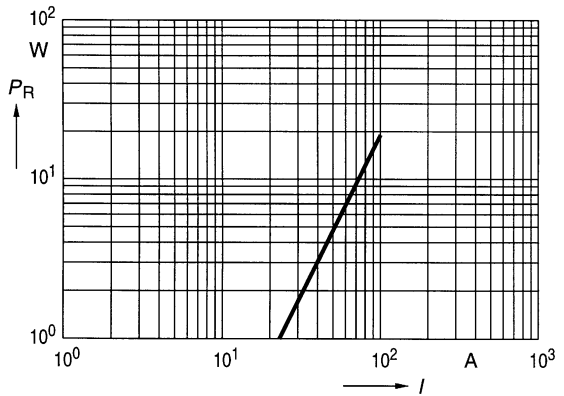

Permissible ambient temperature Θ_A
versus total power dissipation P
(Upright mounting position)

Natural cooling —————
Forced cooling 2 m/s - - - - -
Permissible capacitor
temperature - · - · - ·

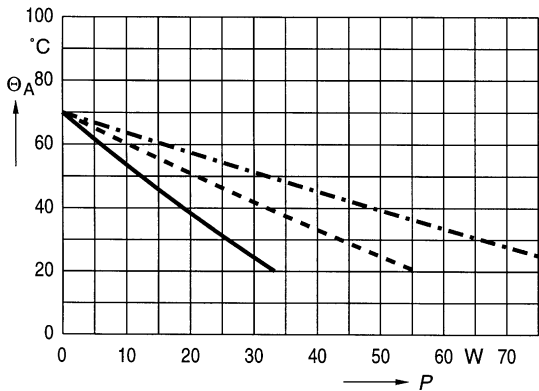

B 25 355

Smoothing, Supporting, Discharge

300 μ F / 1200 Vdc

Ordering code: B25355-L0307-K004

Characteristics

C_N , tol.	300 μ F \pm 10 %
$U_{N(co)}$	DC 1200 V
$U_{N(sto)}$	DC 1500 V
U_i	AC 1100 V
W_N	215 Ws
I_{max}	100 A
L_{self}	200 nH
$\tan \delta_0$	$50 \cdot 10^{-4}$
R_S	1,9 m Ω

Maximum ratings

\hat{u}	1500 V
u_s	1800 V
\hat{i}	40 kA
I_s	75 kA
$(du/dt)_{max}$	100 V/ μ s
$(du/dt)_s$	250 V/ μ s

Test data

U_{TT}	DC 1800 V, 10 s
U_{TC}	AC 3200 V, 10 s
$R_{is} \cdot C$	\geq 5000 s
$\tan \delta$ (120 Hz)	\leq $59 \cdot 10^{-4}$

Climatic data

Θ_{min}	- 40 °C
Θ_{max}	+ 70 °C
Humidity	Average relative humidity \leq 95 %
$\alpha_{FQ(co)}$	$300/10^9$ h
$\alpha_{FQ(sto)}$	$3000/10^9$ h
$t_{LD(co)}$	100000 h
$t_{LD(sto)}$	10000 h
Θ_{stg}	- 55 to + 85 °C

IEC climatic category: 40/070/56

(IEC 68-1 and 2)

Θ_{test}	+ 40 °C
Rel. humidity	93 %
t_{test}	56 days
$\Delta C/C$	\leq 1 %
$\Delta \tan \delta$	\leq $10 \cdot 10^{-4}$
$R_{is} \cdot C$	\geq 5000 s

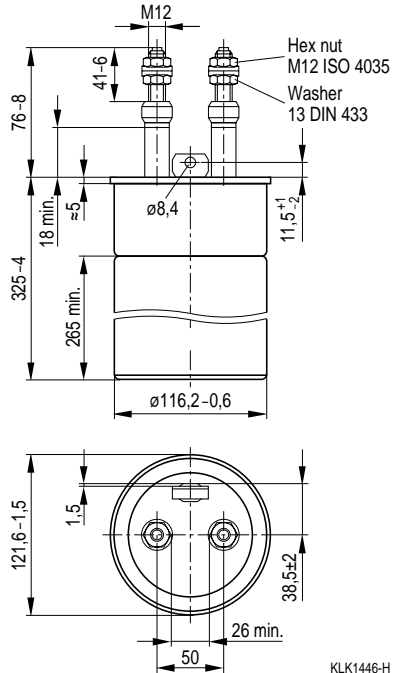

KLK1446-H

Design data

Dimensions $\varnothing \times l$	121,6 mm \times 325 mm
Approx. weight	4500 g
Impregnation	Oil
Terminals	Screw terminals M12
Max. torque	10 Nm
Terminal cross section	16 mm ²
Creepage distance	18 mm
Clearance	18 mm
Overpressure disconnecter	

Thermal data

B25355-L0307-K004

Dielectric power dissipation P_D
versus repetition frequency f_0

$\hat{u}_{ac} = 120 \text{ V}$ —————
 $\hat{u}_{ac} = 108 \text{ V}$ - - - - -

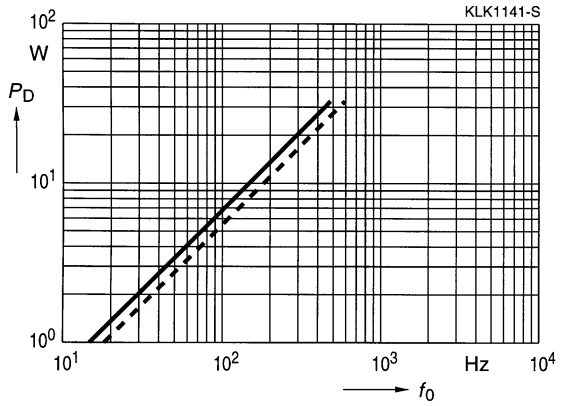

Ohmic power dissipation P_R
versus rms current value I

$R_S (70 \text{ }^\circ\text{C}) = 2,3 \text{ m}\Omega$

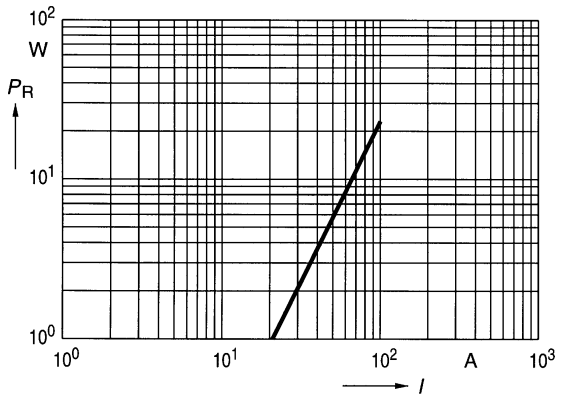

Permissible ambient temperature Θ_A
versus total power dissipation P
(Upright mounting position)

Natural cooling —————
Forced cooling 2 m/s - - - - -
Permissible capacitor
temperature - · - · - ·

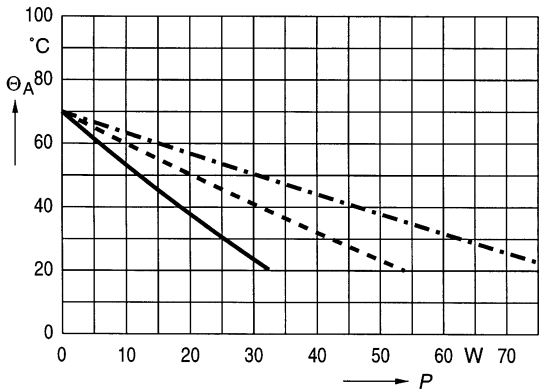

B 25 355

Smoothing, Supporting, Discharge

40 μF / 1600 Vdc

Ordering code: B25355-L1406-K001

Characteristics

C_N , tol.	40 $\mu\text{F} \pm 10\%$
$U_{N(\text{co})}$	DC 1600 V
$U_{N(\text{sto})}$	DC 2000 V
U_i	AC 1450 V
I_{max}	20 A
L_{self}	180 nH
$\tan \delta_0$	$50 \cdot 10^{-4}$
R_S	8,3 m Ω

Maximum ratings

\hat{u}	2000 V
u_s	2400 V
\hat{i}	4 kA
I_s	10 kA
$(du/dt)_{\text{max}}$	100 V/ μs
$(du/dt)_s$	250 V/ μs

Test data

U_{TT}	DC 2400 V, 10 s
U_{TC}	AC 3900 V, 10 s
$R_{is} \cdot C$	≥ 5000 s
$\tan \delta$ (120 Hz)	$\leq 57 \cdot 10^{-4}$

Climatic data

Θ_{min}	-40 °C
Θ_{max}	+70 °C
Humidity	Average relative humidity $\leq 95\%$
$\alpha_{FQ(\text{co})}$	300/10 ⁹ h
$\alpha_{FQ(\text{sto})}$	3000/10 ⁹ h
$t_{LD(\text{co})}$	100000 h
$t_{LD(\text{sto})}$	10000 h
Θ_{stg}	-55 to +85 °C

IEC climatic category: 40/070/56

(IEC 68-1 and 2)

Θ_{test}	+40 °C
Rel. humidity	93 %
t_{test}	56 days
$\Delta C/C$	$\leq 1\%$
$\Delta \tan \delta$	$\leq 10 \cdot 10^{-4}$
$R_{is} \cdot C$	≥ 5000 s

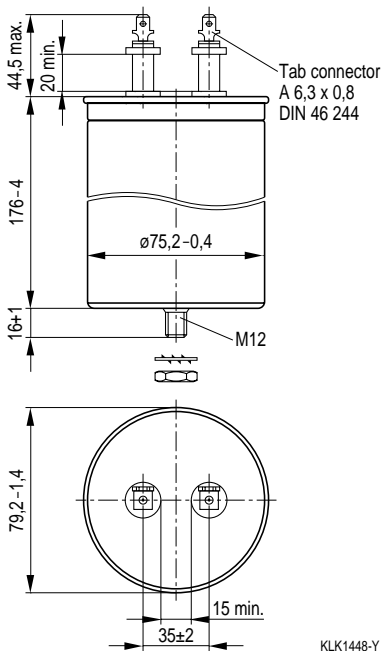

Design data

Dimensions $\varnothing \times l$	79,2 mm \times 176 mm
Approx. weight	1000 g
Impregnation	Oil
Fixing	Threaded bolt M12
Mounting hole	14 mm
Max. torque	10 Nm
Terminals	Tab connector 6,3 mm
Terminal cross section	4 mm ²
Creepage distance	20 mm
Clearance	15 mm
Overpressure disconnecter	

Thermal data

B25355-L1406-K001

Dielectric power dissipation P_D
versus repetition frequency f_0

$\hat{u}_{ac} = 160 \text{ V}$ —————
 $\hat{u}_{ac} = 144 \text{ V}$ - - - - -

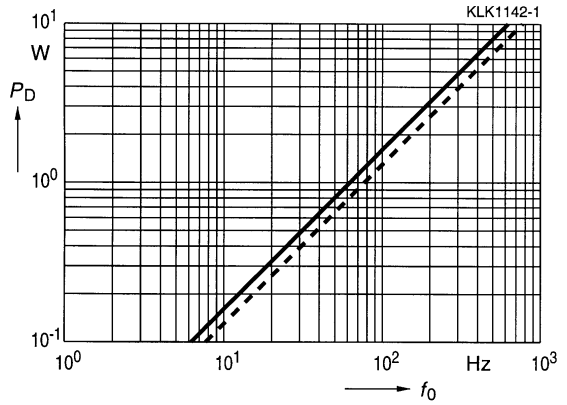

Ohmic power dissipation P_R
versus rms current value I

$R_S (70 \text{ }^\circ\text{C}) = 9,9 \text{ m}\Omega$

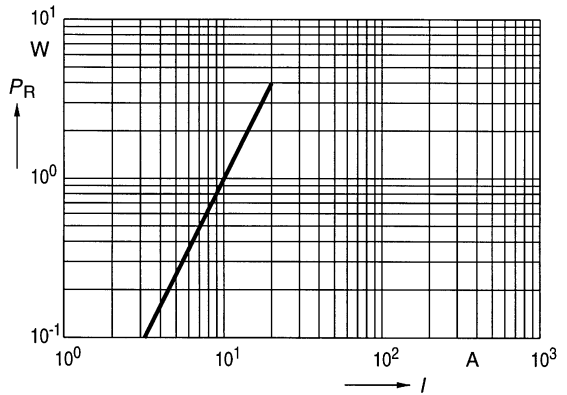

Permissible ambient temperature Θ_A
versus total power dissipation P
(Upright mounting position)

Natural cooling —————
Forced cooling 2 m/s - - - - -
Permissible capacitor
temperature - · - · - ·

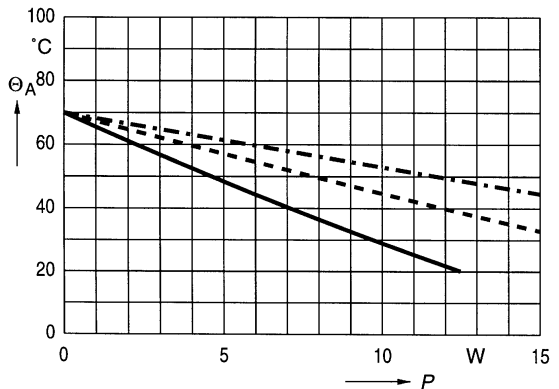

B 25 355

Smoothing, Supporting, Discharge

20 μF / 2000 Vdc

Ordering code: B25355-L2206-K001

Characteristics

C_N , tol.	20 $\mu\text{F} \pm 10\%$
$U_{N(\text{co})}$	DC 2000 V
$U_{N(\text{sto})}$	DC 2500 V
U_i	AC 1800 V
I_{max}	20 A
L_{self}	110 nH
$\tan \delta_0$	$50 \cdot 10^{-4}$
R_S	3,8 m Ω

Maximum ratings

\hat{u}	2500 V
u_s	3000 V
\hat{i}	6 kA
I_s	15 kA
$(du/dt)_{\text{max}}$	300 V/ μs
$(du/dt)_s$	750 V/ μs

Test data

U_{TT}	DC 3000 V, 10 s
U_{TC}	AC 4600 V, 10 s
$R_{is} \cdot C$	≥ 5000 s
$\tan \delta$ (120 Hz)	$\leq 55 \cdot 10^{-4}$

Climatic data

Θ_{min}	-40 $^{\circ}\text{C}$
Θ_{max}	+70 $^{\circ}\text{C}$
Humidity	Average relative humidity $\leq 95\%$
$\alpha_{FQ(\text{co})}$	300/10 ⁹ h
$\alpha_{FQ(\text{sto})}$	3000/10 ⁹ h
$t_{LD(\text{co})}$	100000 h
$t_{LD(\text{sto})}$	10000 h
Θ_{stg}	-55 to +85 $^{\circ}\text{C}$

IEC climatic category: 40/070/56

(IEC 68-1 and 2)

Θ_{test}	+40 $^{\circ}\text{C}$
Rel. humidity	93 %
t_{test}	56 days
$\Delta C/C$	$\leq 1\%$
$\Delta \tan \delta$	$\leq 10 \cdot 10^{-4}$
$R_{is} \cdot C$	≥ 5000 s

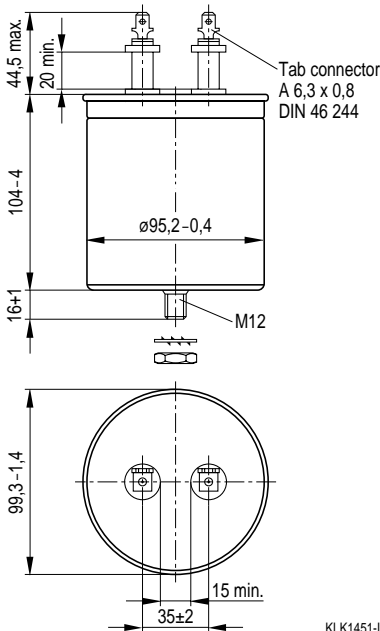

Design data

Dimensions $\varnothing \times l$	99,3 mm \times 104 mm
Approx. weight	950 g
Impregnation	Oil
Fixing	Threaded bolt M12
Mounting hole	14 mm
Max. torque	10 Nm
Terminals	Tab connector 6,3 mm
Terminal cross section	4 mm ²
Creepage distance	20 mm
Clearance	15 mm
Overpressure disconnecter	

Thermal data

B25355-L2206-K001

Dielectric power dissipation P_D
 versus repetition frequency f_0

$\hat{u}_{ac} = 200 \text{ V}$ —————
 $\hat{u}_{ac} = 180 \text{ V}$ - - - - -

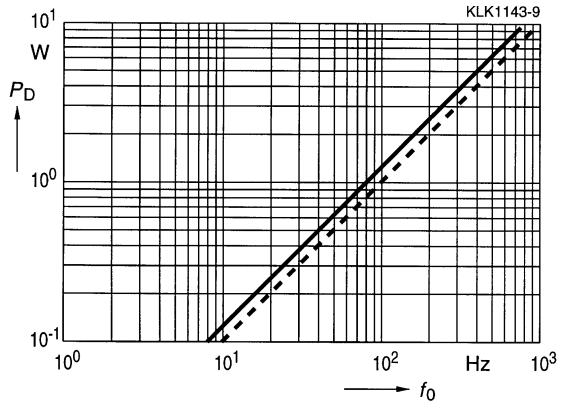

Ohmic power dissipation P_R
 versus rms current value I

$R_S (70 \text{ }^\circ\text{C}) = 4,5 \text{ m}\Omega$

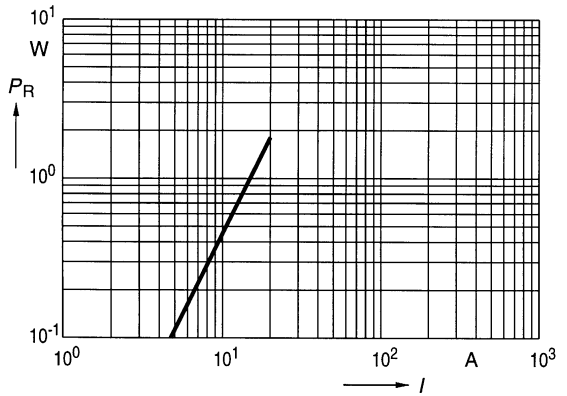

Permissible ambient temperature Θ_A
 versus total power dissipation P
 (Upright mounting position)

Natural cooling —————
 Forced cooling 2 m/s - - - - -
 Permissible capacitor
 temperature - · - · - ·

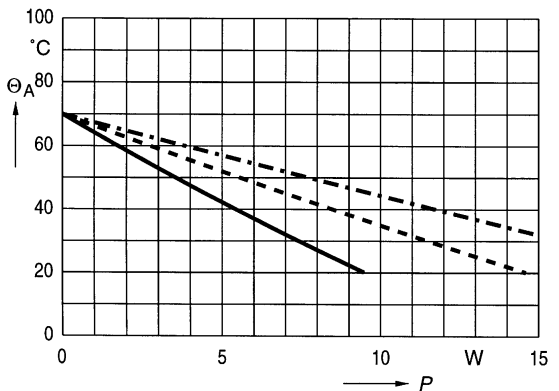

B 25 355

Smoothing, Supporting, Discharge

32 μ F / 2800 Vdc

Ordering code: B25355-L2326-K004

Characteristics

C_N , tol.	32 μ F \pm 10 %
$U_{N(co)}$	DC 2800 V
$U_{N(sto)}$	DC 3500 V
U_i	AC 2500 V
W_N	125 Ws
I_{max}	60 A
L_{self}	220 nH
$\tan \delta_0$	$50 \cdot 10^{-4}$
R_S	5,4 m Ω

Maximum ratings

\hat{u}	3500 V
u_s	4200 V
\hat{i}	7 kA
I_s	18 kA
$(du/dt)_{max}$	220 V/ μ s
$(du/dt)_s$	550 V/ μ s

Test data

U_{TT}	DC 4200 V, 10 s
U_{TC}	AC 6000 V, 10 s
$R_{is} \cdot C$	≥ 5000 s
$\tan \delta$ (120 Hz)	$\leq 56 \cdot 10^{-4}$

Climatic data

Θ_{min}	- 40 $^{\circ}$ C
Θ_{max}	+ 70 $^{\circ}$ C
Humidity	Average relative humidity ≤ 95 %
$\alpha_{FQ(co)}$	300/10 ⁹ h
$\alpha_{FQ(sto)}$	3000/10 ⁹ h
$t_{LD(co)}$	100000 h
$t_{LD(sto)}$	10000 h
Θ_{stg}	- 55 to + 85 $^{\circ}$ C

IEC climatic category: 40/070/56

(IEC 68-1 and 2)

Θ_{test}	+ 40 $^{\circ}$ C
Rel. humidity	93 %
t_{test}	56 days
$\Delta C/C$	≤ 1 %
$\Delta \tan \delta$	$\leq 10 \cdot 10^{-4}$
$R_{is} \cdot C$	≥ 5000 s

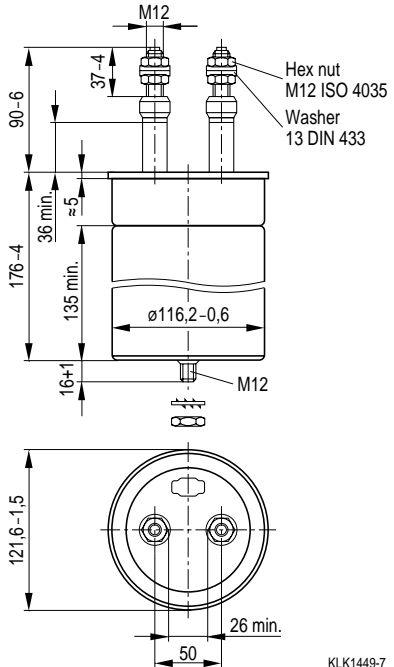

KLK1449-7

Design data

Dimensions $\varnothing \times l$	121,6 mm \times 176 mm
Approx. weight	2500 g
Impregnation	Oil
Fixing	Threaded bolt M12
Mounting hole	14 mm
Max. torque	10 Nm
Terminals	Screw terminals M12
Max. torque	10 Nm
Terminal cross section	16 mm ²
Creepage distance	36 mm
Clearance	26 mm
Overpressure disconnecter	

Thermal data

B25355-L2326-K004

Dielectric power dissipation P_D
versus repetition frequency f_0

$\hat{u}_{ac} = 280 \text{ V}$ —————
 $\hat{u}_{ac} = 252 \text{ V}$ - - - - -

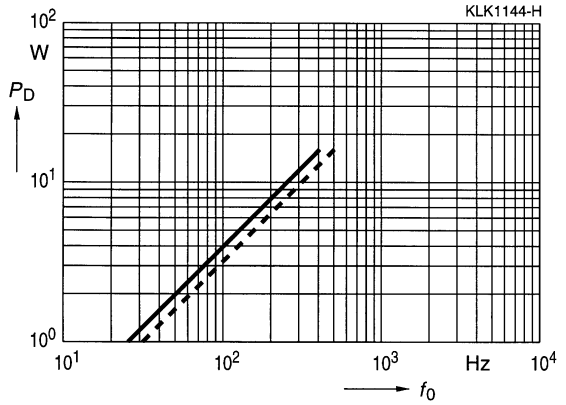

Ohmic power dissipation P_R
versus rms current value I

$R_S (70 \text{ }^\circ\text{C}) = 6,6 \text{ m}\Omega$

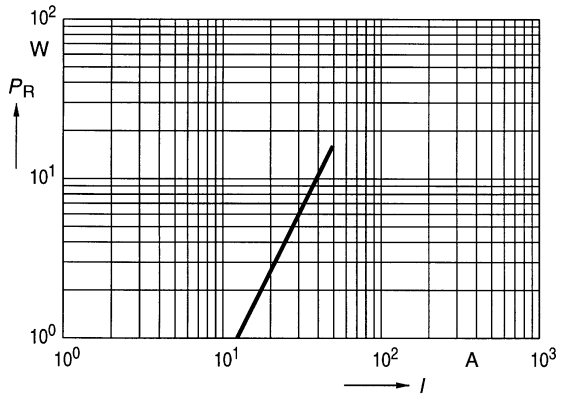

Permissible ambient temperature Θ_A
versus total power dissipation P
(Upright mounting position)

Natural cooling —————
Forced cooling 2 m/s - - - - -
Permissible capacitor
temperature - · - · - ·

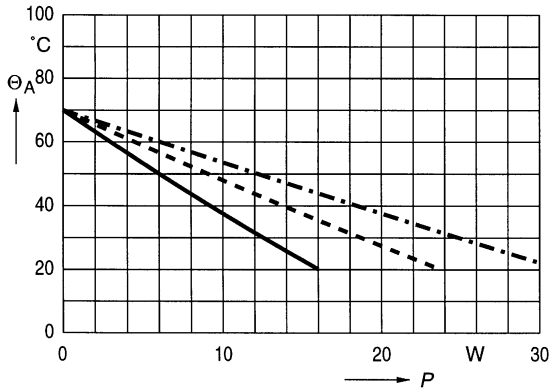

B 25 355

Smoothing, Supporting, Discharge

0,5 μF / 3200 Vdc

Ordering code: B25355-J3504-K001

Characteristics

C_N , tol.	0,5 $\mu\text{F} \pm 10\%$
$U_{N(\text{co})}$	DC 3200 V
$U_{N(\text{sto})}$	DC 4000 V
U_i	AC 2900 V
I_{max}	16 A
L_{self}	70 nH
$\tan \delta_0$	$50 \cdot 10^{-4}$
R_S	16 m Ω

Maximum ratings

\hat{u}	4000 V
u_s	4800 V
\hat{i}	500 A
I_s	1200 A
$(du/dt)_{\text{max}}$	1000 V/ μs
$(du/dt)_s$	2500 V/ μs

Test data

U_{TT}	DC 4800 V, 10 s
U_{TC}	AC 6800 V, 10 s
R_{is}	$\geq 5000 \text{ M}\Omega$
$\tan \delta$ (1 kHz)	$\leq 100 \cdot 10^{-4}$

Climatic data

Θ_{min}	-40 °C
Θ_{max}	+70 °C
Humidity	Average relative humidity $\leq 95\%$
$\alpha_{\text{FQ}(\text{co})}$	$300/10^9 \text{ h}$
$\alpha_{\text{FQ}(\text{sto})}$	$3000/10^9 \text{ h}$
$t_{\text{LD}(\text{co})}$	100000 h
$t_{\text{LD}(\text{sto})}$	10000 h
Θ_{stg}	-55 to +85 °C

IEC climatic category: 40/070/56

(IEC 68-1 and 2)

Θ_{test}	+40 °C
Rel. humidity	93 %
t_{test}	56 days
$\Delta C/C$	$\leq 1\%$
$\Delta \tan \delta$	$\leq 10 \cdot 10^{-4}$
R_{is}	$\geq 5000 \text{ M}\Omega$

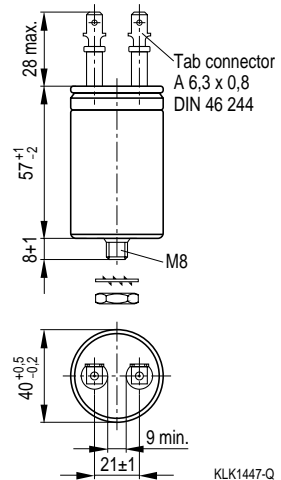

KLK1447-Q

Design data

Dimensions $\varnothing \times l$	40 mm \times 57 mm
Approx. weight	90 g
Impregnation	Oil
Fixing	Threaded bolt M8
Mounting hole	9,5 mm
Max. torque	4 Nm
Terminals	Tab connector 6,3 mm
Terminal cross section	1,5 mm 2
Creepage distance	10,0 mm
Clearance	9,0 mm
Overpressure disconnecter	

Thermal data

B25355-J3504-K001

Dielectric power dissipation P_D
versus repetition frequency f_0

$\hat{u}_{ac} = 320 \text{ V}$ —————
 $\hat{u}_{ac} = 288 \text{ V}$ - - - - -

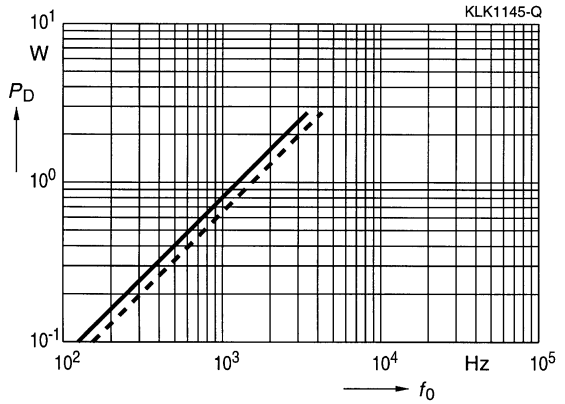

Ohmic power dissipation P_R
versus rms current value I

$R_S (70 \text{ }^\circ\text{C}) = 19 \text{ m}\Omega$

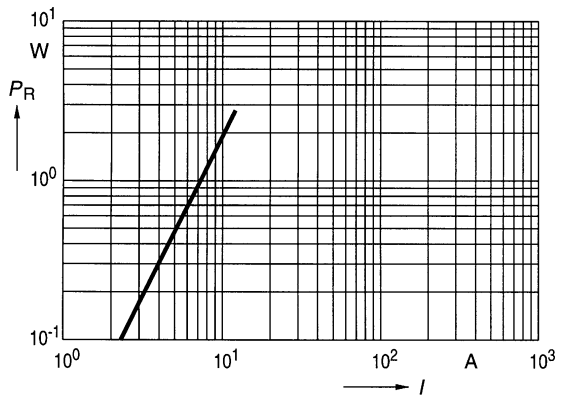

Permissible ambient temperature Θ_A
versus total power dissipation P
(Upright mounting position)

Natural cooling —————
Forced cooling 2 m/s - - - - -
Permissible capacitor
temperature - · - · - ·

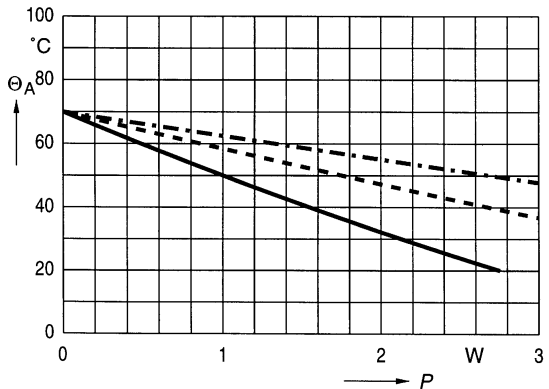

B 25 355

Smoothing, Supporting, Discharge

4 μF / 6300 Vdc

Ordering code: B25355-G6405-K001

Characteristics

C_N , tol.	4 $\mu\text{F} \pm 10\%$
$U_{N(\text{co})}$	DC 6300 V
$U_{N(\text{sto})}$	DC 7900 V
I_{max}	20 A
L_{self}	180 nH
$\tan \delta_0$	$50 \cdot 10^{-4}$
R_S	10 m Ω

Maximum ratings

\hat{u}	7900 V
u_s	9500 V
\hat{i}	4 kA
I_s	10 kA
$(du/dt)_{\text{max}}$	1000 V/ μs
$(du/dt)_s$	2500 V/ μs

Test data

U_{TT}	DC 9500 V, 10 s
$R_{\text{is}} \cdot C$	≥ 5000 s
$\tan \delta$ (1 kHz)	$\leq 100 \cdot 10^{-4}$

Climatic data

Θ_{min}	-40 °C
Θ_{max}	+70 °C
Humidity	Average relative humidity $\leq 95\%$
$\alpha_{\text{FQ}(\text{co})}$	300/10 ⁹ h
$\alpha_{\text{FQ}(\text{sto})}$	3000/10 ⁹ h
$t_{\text{LD}(\text{co})}$	100000 h
$t_{\text{LD}(\text{sto})}$	10000 h
Θ_{stg}	-55 to +85 °C

IEC climatic category: 40/070/56

(IEC 68-1 and 2)

Θ_{test}	+40 °C
Rel. humidity	93 %
t_{test}	56 days
$\Delta C/C$	$\leq 1\%$
$\Delta \tan \delta$	$\leq 10 \cdot 10^{-4}$
$R_{\text{is}} \cdot C$	≥ 5000 s

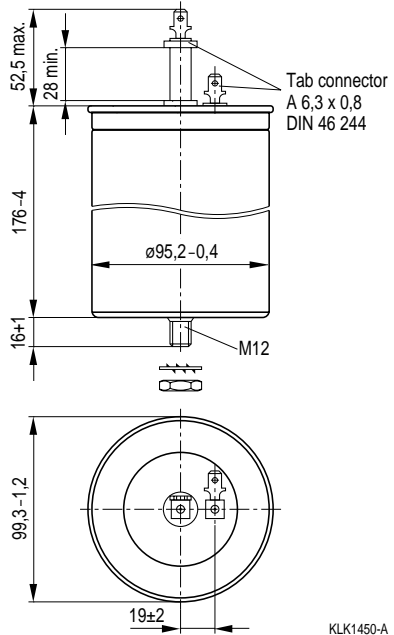

Design data

Dimensions $\varnothing \times l$	99,3 mm \times 176 mm
Approx. weight	1600 g
Impregnation	Oil
Fixing	Threaded bolt M12
Mounting hole	14 mm
Max. torque	10 Nm
Terminals	Tab connector 6,3 mm
Terminal cross section	4 mm ²
Creepage distance	28 mm
Clearance	26 mm
Overpressure disconnecter	

Thermal data

B25355-G6405-K001

Dielectric power dissipation P_D
versus repetition frequency f_0

$\hat{u}_{ac} = 630 \text{ V}$ —————
 $\hat{u}_{ac} = 567 \text{ V}$ - - - - -

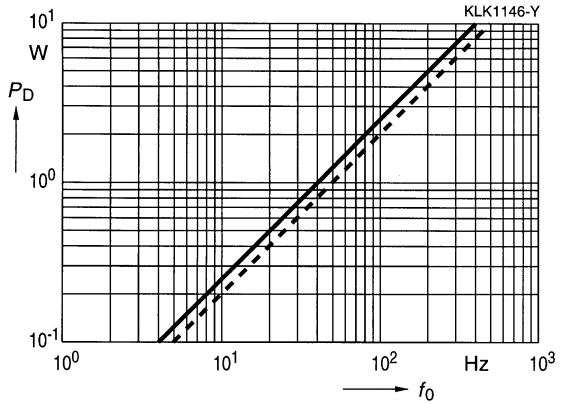

Ohmic power dissipation P_R
versus rms current value I

$R_S (70 \text{ }^\circ\text{C}) = 12 \text{ m}\Omega$

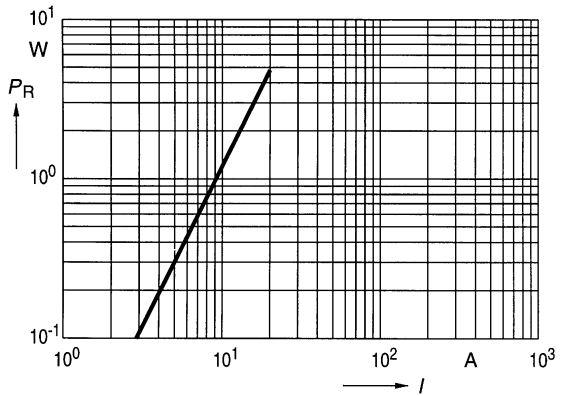

Permissible ambient temperature Θ_A
versus total power dissipation P
(Upright mounting position)

Natural cooling —————
Forced cooling 2 m/s - - - - -
Permissible capacitor
temperature - · - · - ·

