

Silicon Schottky Diode

- For low-loss, fast-recovery, meter protection, bias isolation and clamping applications
- Integrated diffused guard ring
- Low forward voltage

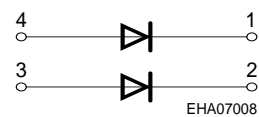
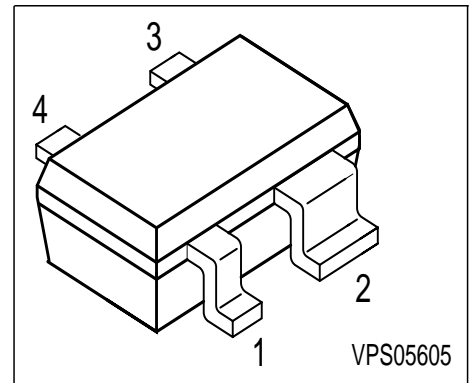

ESD: Electrostatic discharge sensitive device, observe handling precaution!

Type	Marking	Pin Configuration				Package
BAS125-07W	17s	1 = C1	2 = C2	3 = A2	4 = A1	SOT343

Maximum Ratings

Parameter	Symbol	Value	Unit
Diode reverse voltage	V_R	25	V
Forward current	I_F	100	mA
Surge forward current ($t < 100\mu s$)	I_{FSM}	500	
Total power dissipation, $T_S = 96\text{ }^\circ\text{C}$	P_{tot}	250	mW
Junction temperature	T_j	150	$^\circ\text{C}$
Storage temperature	T_{stg}	-55 ... 150	

Maximum Ratings

Junction - soldering point ¹⁾	R_{thJS}	≤ 215	K/W
--	------------	------------	-----

¹⁾For calculation of R_{thJA} please refer to Application Note Thermal Resistance

Electrical Characteristics at $T_A = 25^\circ\text{C}$, unless otherwise specified.

Parameter	Symbol	Values			Unit
		min.	typ.	max.	
DC characteristics					
Reverse current $V_R = 20\text{ V}$ $V_R = 25\text{ V}$	I_R	-	-	100 150	nA
Forward voltage $I_F = 1\text{ mA}$ $I_F = 10\text{ mA}$ $I_F = 35\text{ mA}$	V_F	-	385 530 800	400 650 950	mV
AC characteristics					
Diode capacitance $V_R = 0\text{ V}, f = 1\text{ MHz}$	C_T	-	-	1.1	pF
Differential forward resistance $I_F = 5\text{ mA}, f = 10\text{ kHz}$	R_f	-	16	-	Ω

Forward current $I_F = f(V_F)$

$T_A =$ Parameter

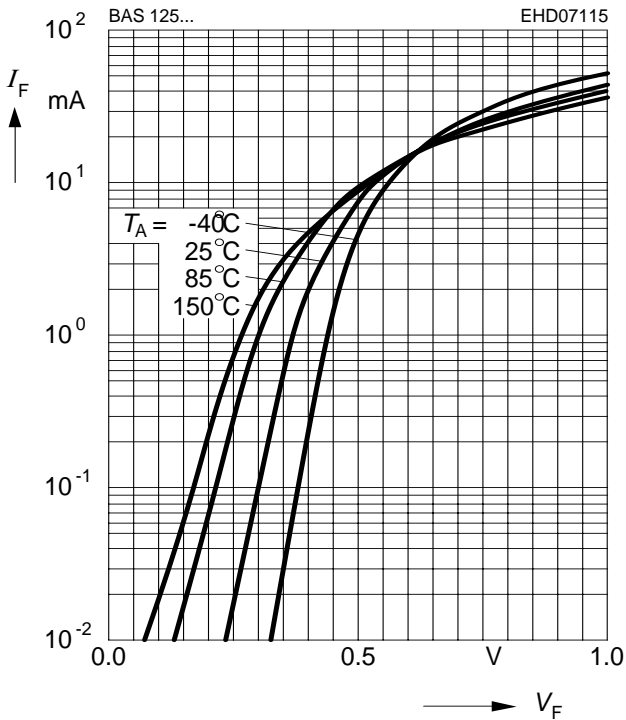

Total power dissipation $P_{tot} = f(T_S)$

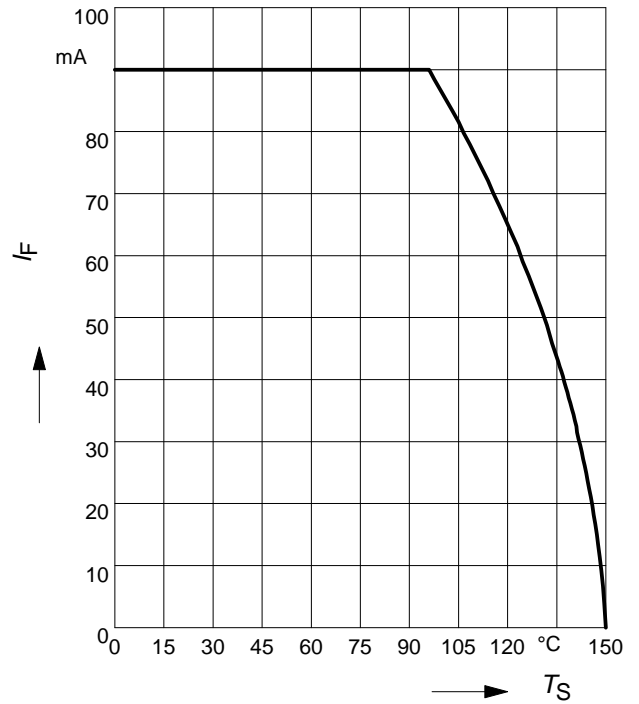

Reverse current $I_R = f(V_R)$

$T_A =$ Parameter

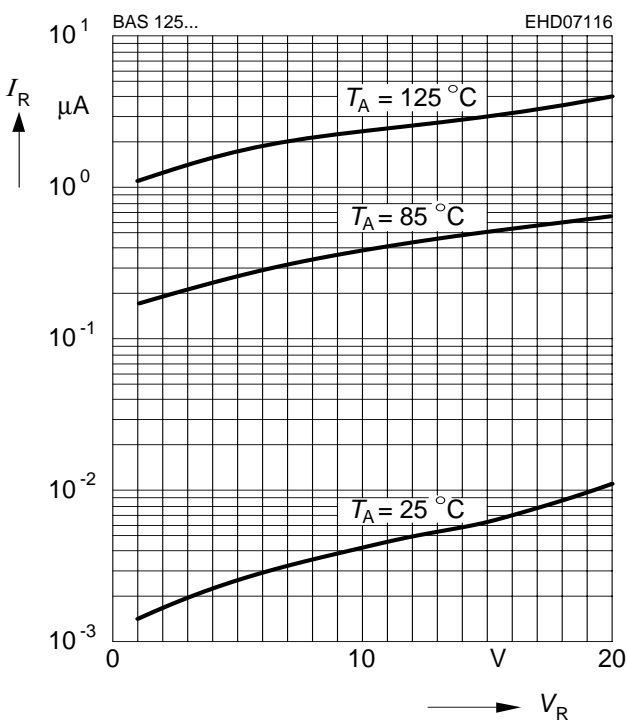

Differential forward resistance $r_f = f(I_F)$

$f = 10 \text{ kHz}$

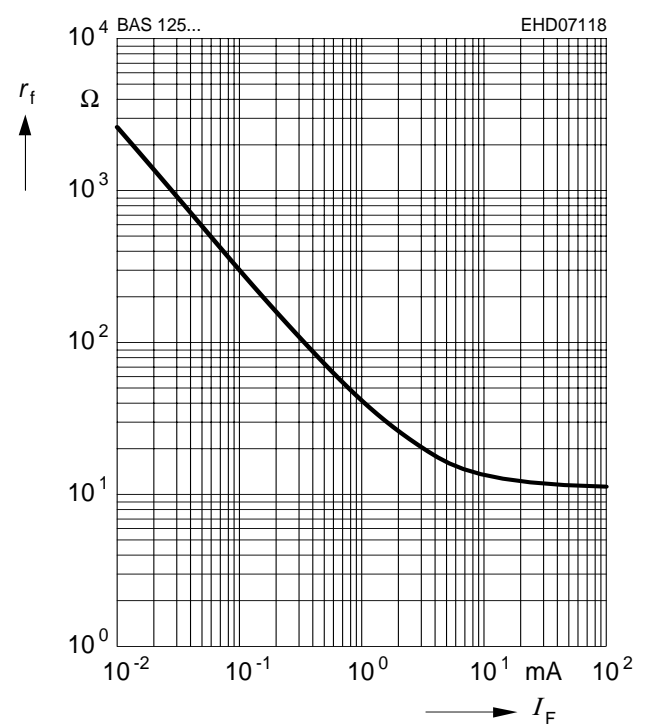

Diode capacitance $C_T = f(V_R)$

$f = 1\text{MHz}$

