



ATSC/VSB DIGITAL CABLE READY DTV RECEIVER

FEATURES

- **Integrated VSB/QAM QAMLink® Receiver**
 - 12-bit A/D converter with internal AGC amplifier
 - Full equalizer architecture spans up to -35 to 49 μ s delays
 - Direct IF sampled architecture reduces system cost
 - Single IF signal path for QAM/VSB to reduce system costs
 - ITU-T J.83 Annex A/B/C FEC modes
 - MPEG-2 transport output (serial/parallel)
 - All-digital clock and carrier recovery
 - Integrated PLLs to minimize external components
 - All acquisition times typically less than 50 ms
- **QPSK Out-of-Band Receiver**
 - 100–200-MHz receiver LO with input AGC and 6-bit A/D
 - Variable symbol rate QPSK receiver
 - Digital demodulator, Nyquist filters, tracking loops, and four-tap adaptive equalizer
 - DVS-167 (Davic™)/DVS-178 (DigiCipherII™) FEC decoder
- **Integrated Acquisition Controller**
- **EIA/CEA-909 Antenna Interface**
- **144-pin LQFP Package**

SUMMARY OF BENEFITS

- Complete DTV single chip receiver solution
- FCC VSB and Digital Cable Ready
- Superior performance under both static and dynamic multi-path channel conditions
- Direct interface to CMOS and discrete DTV tuners
- Reduces system costs through direct IF sampling
- Single IF path for QAM/VSB simplifies board design
- Smart antenna support
- Automatic NTSC co-channel interference and RFI rejection filters
- Integrated de-interleaver RAM for VSB FEC, and QAM for modes up to J=4 reduces system costs
- BSC master to control peripherals

Digital Cable Ready DTV System Solution

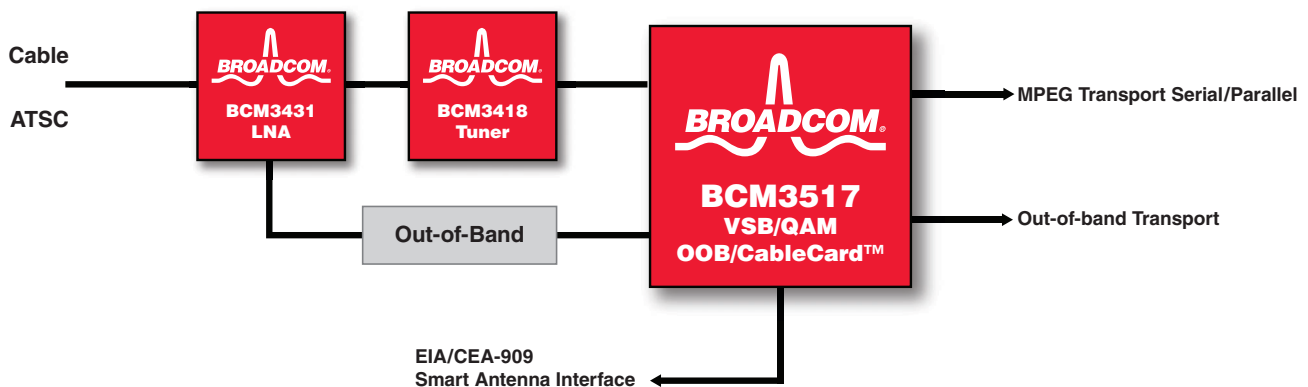

OVERVIEW

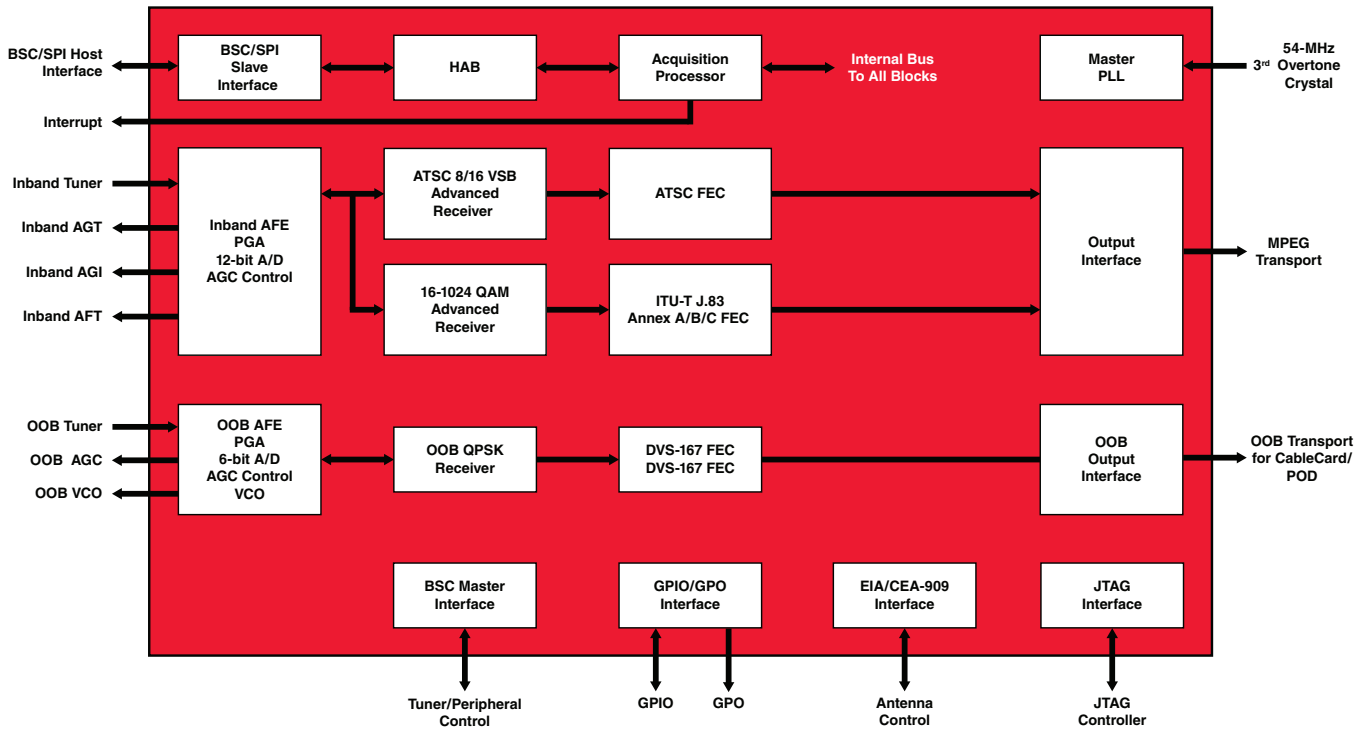

BCM3517 Block Diagram

The BCM3517 is an ATSC/VSB Digital Cable Ready DTV receiver that contains a digital receiver that is compatible with both North American digital cable television and digital terrestrial broadcast television standards. This receiver is capable of receiving all standard-definition and high-definition digital formats (SDTV/HDTV). An out-of-band QPSK receiver is also contained to meet the needs of the CableCARD specification.

The BCM3517's digital receiver accepts an analog signal centered at the standard television IF frequencies, and amplifies and digitizes this signal with an integrated programmable gain amplifier and 12-bit A/D converter. The output of the A/D is sent to the receiver and demodulator. The digital receiver consists of a QAM demodulator and a VSB demodulator. Each demodulator contains adaptive filters that remove

multipath propagation effects, NTSC co-channel interference, and RFI interference. The output of the VSB demodulator goes to an ATSC A/53 coding forward error corrector (FEC), with integrated trellis and Reed-Solomon decoder. The output of the QAM demodulator goes to an ITU-T J.83 Annex A/B/C coding FEC. The output of either QAM or VSB FEC is delivered in either parallel or serial MPEG-2 transport format.

All gain, clock, and carrier, acquisition, and tracking loops are integrated on-chip as are the necessary phase-locked loops, referenced to a single external crystal.

Chip configuration, channel acquisition, and performance monitoring functions are conducted by the on-chip acquisition processor using Broadcom-provided software.

Broadcom®, the pulse logo, QAMLink®, Connecting everything®, and the Connecting everything logo are among the trademarks of Broadcom Corporation and/or its affiliates in the United States, certain other countries and/or the EU. Any other trademarks or trade names mentioned are the property of their respective owners.

Connecting
everything®



BROADCOM CORPORATION
16215 Alton Parkway, P.O. Box 57013
Irvine, California 92619-7013

© 2006 by BROADCOM CORPORATION. All rights reserved.

3517-PB03-R 10/23/06

Phone: 949-450-8700
Fax: 949-450-8710
E-mail: info@broadcom.com
Web: www.broadcom.com