

Type	BMS-2508H
Rated Impedance(Ω)	$8 \pm 15\%$
Rated(Max.) Power(W)	0.1(0.2)
Resonant Frequency(Hz)	$1000 \pm 20\%$
Rated Freq.Range(Hz)	$f_0 \sim 3200$
Sound Pressure Level(dB)	75 ± 3
Magnet(g)	1.7
Operating Temperature($^{\circ}\text{C}$)	$-40 \sim +85$

OEM pin or extented wire with connector

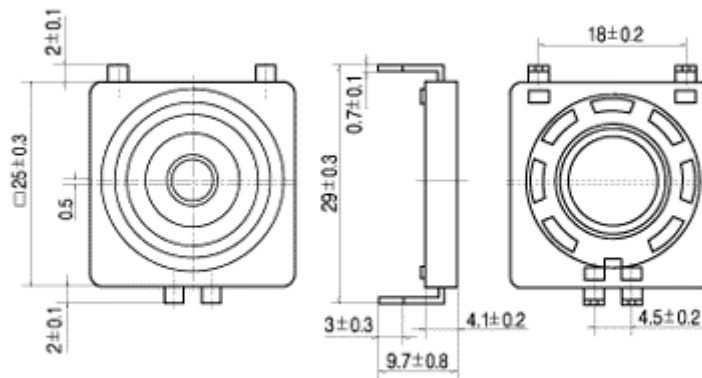

Unit:mm

