

High voltage fast-switching NPN power transistor

General features

- High voltage capability
- Low spread of dynamic parameters
- Minimum lot-to-lot spread for reliable operation
- Very high switching speed
- High ruggedness
- Surface mounting TO-263 (D²PAK) power package
- In compliance with the 2002/93/EC European Directive

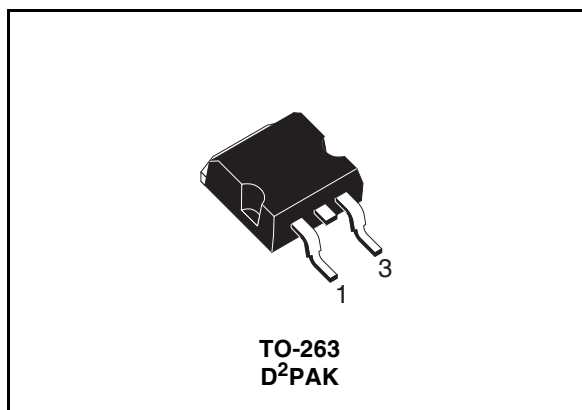

Description

The device is manufactured using high voltage Multi-Epitaxial Planar technology for high switching speeds and high voltage capability.

The device is designed for use in electronic transformer for halogen lamps.

Applications

- Electronic transformers for halogen lamps
- Flyback and forward single transistor low power converters

Internal schematic diagrams

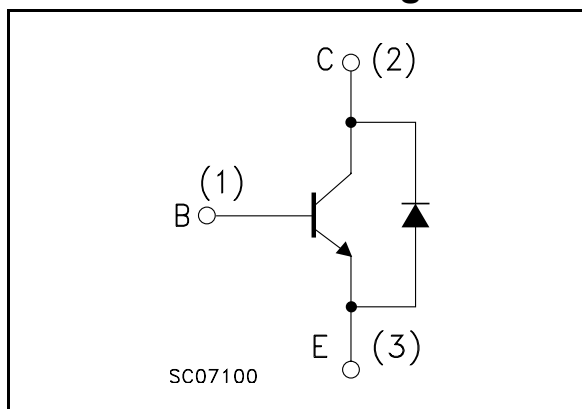

Order codes

Part Number	Marking	Package	Packing
BULB49DT4	BULB49D	D ² PAK	Tape & reel

Contents

1	Electrical ratings	3
2	Electrical characteristics	4
2.1	Electrical characteristics (curves)	5
2.2	Test circuits	7
3	Package mechanical data	8
4	Revision history	10

1 Electrical ratings

Table 1. Absolute maximum ratings

Symbol	Parameter	Value	Unit
V_{CES}	Collector-emitter voltage ($V_{BE} = 0$)	850	V
V_{CEO}	Collector-emitter voltage ($I_B = 0$)	450	V
V_{EBO}	Emitter-base voltage ($I_C = 0, I_B < 2A, t_P < 10ms$)	$V_{(BR)EBO}$	V
I_C	Collector current	5	A
I_{CM}	Collector peak current ($t_P < 5ms$)	10	A
I_B	Base current	2	A
I_{BM}	Base peak current ($t_P < 5ms$)	4	A
P_{tot}	Total dissipation at $T_C \leq 25^\circ C$	80	W
T_{stg}	Storage temperature	-65 to 150	$^\circ C$
T_J	Max. operating junction temperature	150	$^\circ C$

Table 2. Thermal data

Symbol	Parameter	Value	Unit
$R_{thj-case}$	Thermal resistance junction-case max	1.56	$^\circ C/W$
$R_{thj-amb}$	Thermal resistance junction-ambient max	62.5	$^\circ C/W$

2 Electrical characteristics

($T_{\text{case}} = 25^{\circ}\text{C}$ unless otherwise specified)

Table 3. Electrical characteristics

Symbol	Parameter	Test Conditions	Min.	Typ.	Max.	Unit
I_{CES}	Collector cut-off current ($V_{\text{BE}} = 0$)	$V_{\text{CE}} = 850\text{V}$ $V_{\text{CE}} = 850\text{V}$ $T_j = 125^{\circ}\text{C}$			100 500	μA μA
I_{EBO}	Emitter cut-off current ($I_{\text{C}} = 0$)	$V_{\text{EB}} = 9\text{V}$			100	μA
$V_{(\text{BR})\text{EBO}}$	Emitter-base breakdown voltage ($I_{\text{C}} = 0$)	$I_{\text{E}} = 10\text{mA}$	10		18	V
$V_{\text{CEO(sus)}}^{(1)}$	Collector-emitter sustaining voltage ($I_{\text{B}} = 0$)	$I_{\text{C}} = 10\text{mA}$	450			V
$V_{\text{CE(sat)}}^{(1)}$	Collector-emitter saturation voltage	$I_{\text{C}} = 1\text{A}$ $I_{\text{B}} = 0.2\text{A}$ $I_{\text{C}} = 2\text{A}$ $I_{\text{B}} = 0.4\text{A}$ $I_{\text{C}} = 4\text{A}$ $I_{\text{B}} = 0.8\text{A}$		0.1	0.3 0.6 1.2	V V V
$V_{\text{BE(sat)}}^{(1)}$	Base-emitter saturation voltage	$I_{\text{C}} = 1\text{A}$ $I_{\text{B}} = 0.2\text{A}$ $I_{\text{C}} = 4\text{A}$ $I_{\text{B}} = 0.8\text{A}$			1 1.3	V V
$h_{\text{FE}}^{(1)}$	DC current gain	$I_{\text{C}} = 10\text{mA}$ $V_{\text{CE}} = 5\text{V}$ $I_{\text{C}} = 500\text{mA}$ $V_{\text{CE}} = 5\text{V}$ $I_{\text{C}} = 7\text{A}$ $V_{\text{CE}} = 10\text{V}$	10 4		60 10	
$V_{\text{CEW}}^{(1)}$	Maximum collector- emitter voltage without snubber	$I_{\text{C}} = 8\text{A}$ $V_{\text{BB}} = -2.5\text{V}$ $L = 50\mu\text{H}$ $R_{\text{BB}} = 0$ $t_{\text{p}} = 10\mu\text{s}$	450			V
t_{s} t_{f}	Resistive load Storage time Fall time	$V_{\text{CC}} = 250\text{V}$ $I_{\text{C}} = 2\text{A}$ $I_{\text{B1}} = -I_{\text{B2}} = 400\text{mA}$ $t_{\text{p}} = 30\mu\text{s}$ (see figure 11)	2		3 0.8	μs μs
t_{s} t_{f}	Inductive load Storage time Fall time	$V_{\text{CL}} = 300\text{V}$ $I_{\text{C}} = 4\text{A}$ $I_{\text{B(on)}} = 800\text{mA}$ $R_{\text{BB(off)}} = 0$ $V_{\text{BE(off)}} = -5\text{V}$ $L = 1\text{mH}$ (see figure 12)		0.5 50	1.3 100	μs ns
V_{F}	Diode forward voltage	$I_{\text{C}} = 3\text{A}$			1.5	V

Note (1) Pulsed duration = 300 μs , duty cycle $\leq 1.5\%$

2.1 Electrical characteristics (curves)

Figure 1. Safe operating area

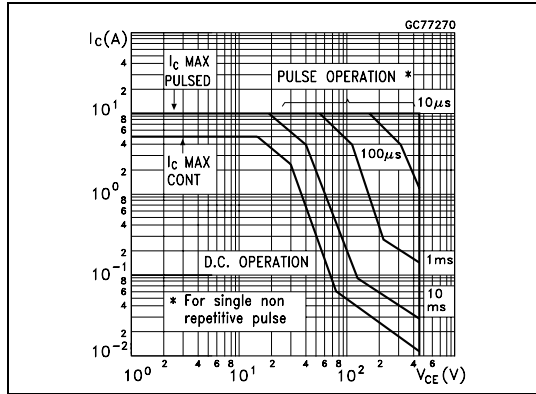

Figure 2. Derating current

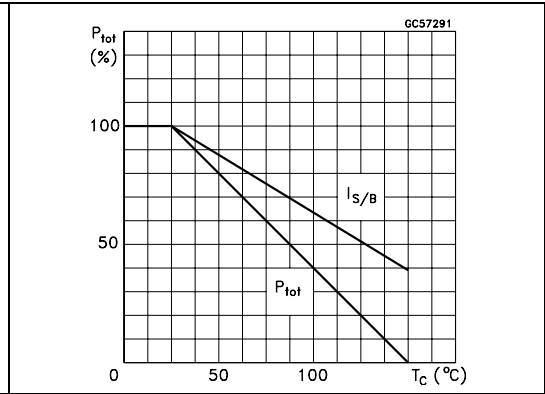

Figure 3. Output characteristics

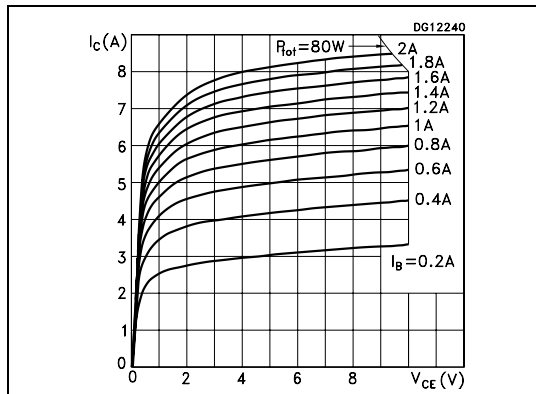

Figure 4. Collector-emitter saturation voltage

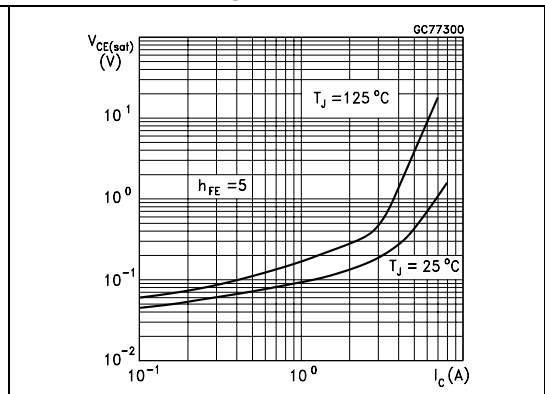

Figure 5. Base-emitter saturation voltage

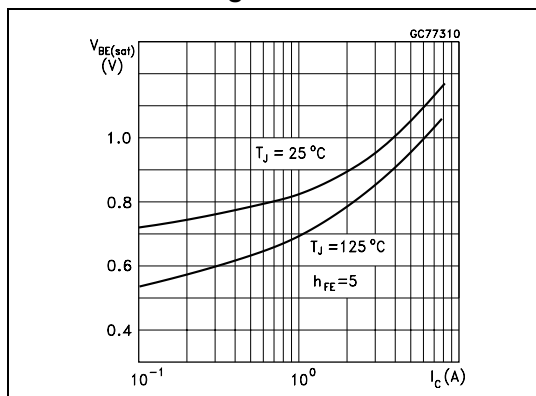

Figure 6. DC current gain

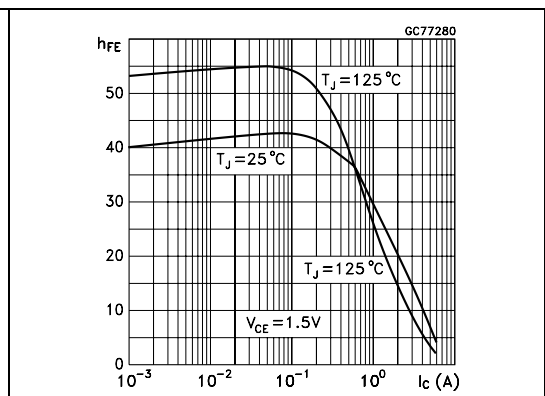

Figure 7. DC current gain

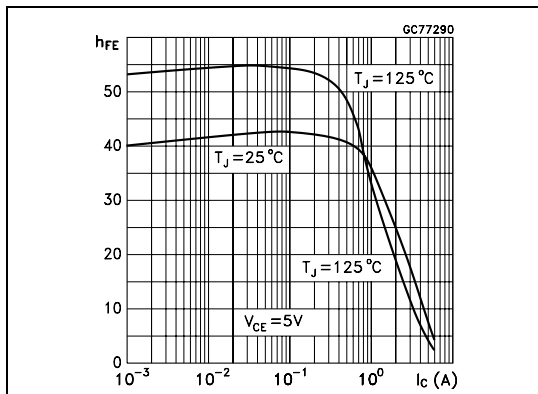

Figure 8. Inductive load storage time

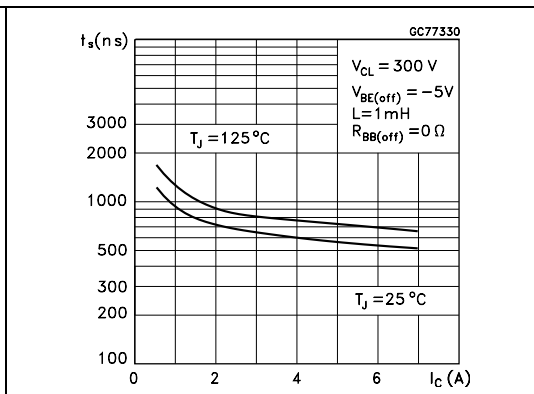

Figure 9. Inductive load fall time

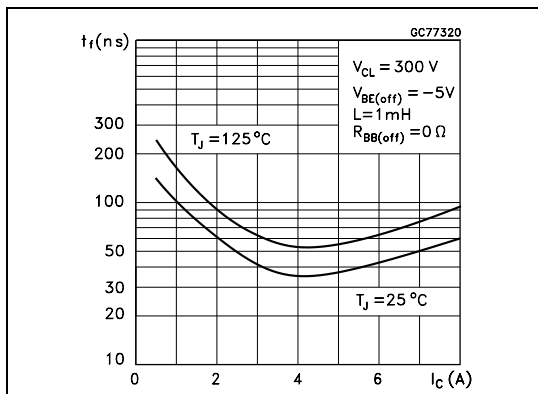
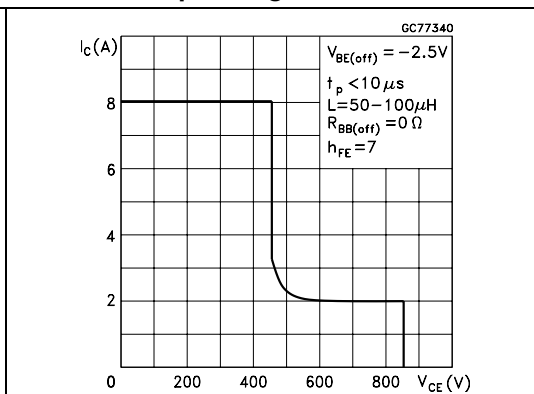

Figure 10. Reverse biased safe operating area



2.2 Test circuits

Figure 11. Resistive load switching test circuit

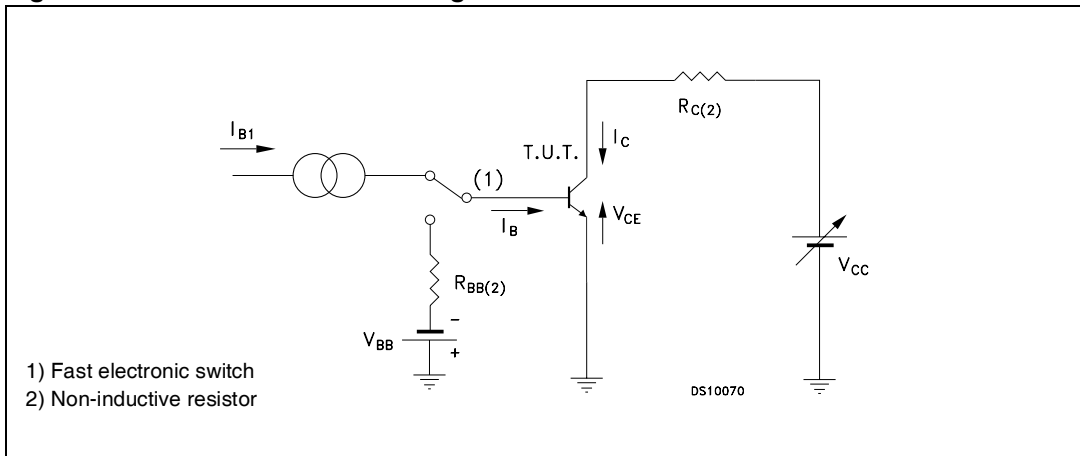
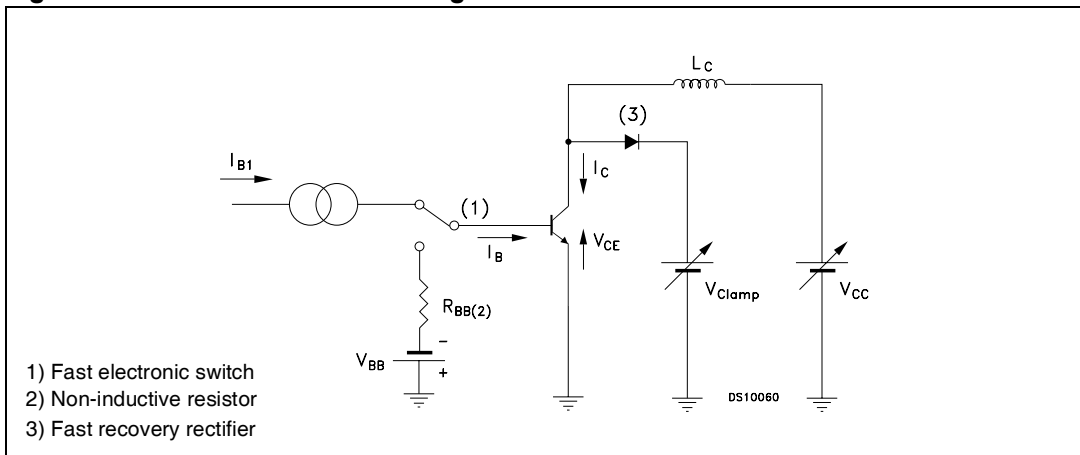

Figure 12. Inductive load switching test circuit



3 Package mechanical data

In order to meet environmental requirements, ST offers these devices in ECOPACK® packages. These packages have a Lead-free second level interconnect. The category of second level interconnect is marked on the package and on the inner box label, in compliance with JEDEC Standard JESD97. The maximum ratings related to soldering conditions are also marked on the inner box label. ECOPACK is an ST trademark. ECOPACK specifications are available at: www.st.com

TO-263 (D²PAK) MECHANICAL DATA

DIM.	mm			inch		
	MIN.	TYP.	MAX.	MIN.	TYP.	MAX.
A	4.40		4.60	0.173		0.181
A1	2.49		2.69	0.098		0.106
A2	0.03		0.23	0.001		0.009
B	0.70		0.93	0.027		0.036
B2	1.14		1.70	0.044		0.067
C	0.45		0.60	0.017		0.023
C2	1.23		1.36	0.048		0.053
D	8.95		9.35	0.352		0.368
D1		8.00			0.315	
E	10.00		10.40	0.393		0.409
E1		8.50			0.334	
G	4.88		5.28	0.192		0.208
L	15.00		15.85	0.590		0.624
L2	1.27		1.4	0.050		0.055
L3	1.40		1.75	0.055		0.068
M	2.40		3.2	0.094		0.126
R		0.40			0.016	
V2	0°		8°	0°		8°

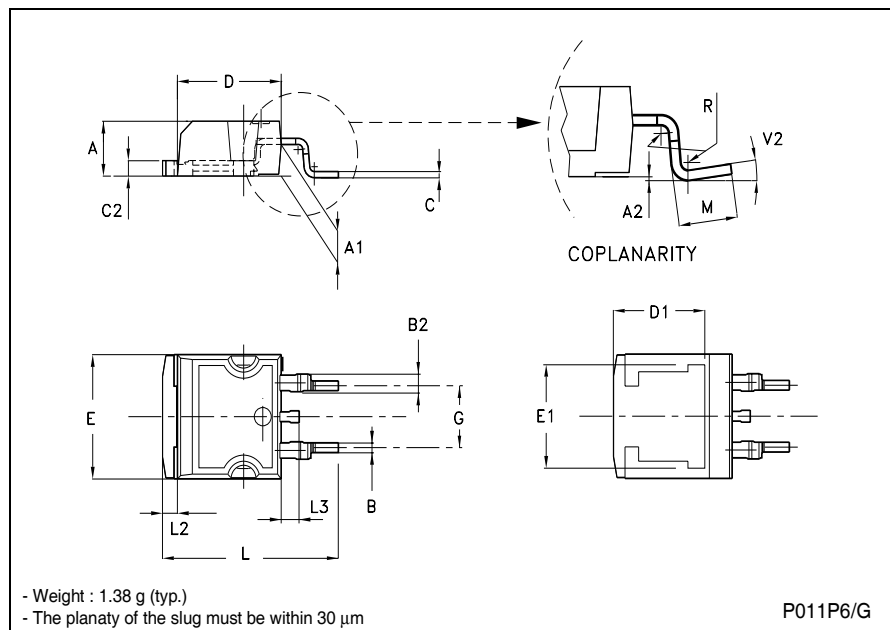

4 Revision history

Table 4. Revision history

Date	Revision	Changes
10-Sep-2003	1	First release.
21-Jul-2006	2	New template

Please Read Carefully:

Information in this document is provided solely in connection with ST products. STMicroelectronics NV and its subsidiaries ("ST") reserve the right to make changes, corrections, modifications or improvements, to this document, and the products and services described herein at any time, without notice.

All ST products are sold pursuant to ST's terms and conditions of sale.

Purchasers are solely responsible for the choice, selection and use of the ST products and services described herein, and ST assumes no liability whatsoever relating to the choice, selection or use of the ST products and services described herein.

No license, express or implied, by estoppel or otherwise, to any intellectual property rights is granted under this document. If any part of this document refers to any third party products or services it shall not be deemed a license grant by ST for the use of such third party products or services, or any intellectual property contained therein or considered as a warranty covering the use in any manner whatsoever of such third party products or services or any intellectual property contained therein.

UNLESS OTHERWISE SET FORTH IN ST'S TERMS AND CONDITIONS OF SALE ST DISCLAIMS ANY EXPRESS OR IMPLIED WARRANTY WITH RESPECT TO THE USE AND/OR SALE OF ST PRODUCTS INCLUDING WITHOUT LIMITATION IMPLIED WARRANTIES OF MERCHANTABILITY, FITNESS FOR A PARTICULAR PURPOSE (AND THEIR EQUIVALENTS UNDER THE LAWS OF ANY JURISDICTION), OR INFRINGEMENT OF ANY PATENT, COPYRIGHT OR OTHER INTELLECTUAL PROPERTY RIGHT.

UNLESS EXPRESSLY APPROVED IN WRITING BY AN AUTHORIZED REPRESENTATIVE OF ST, ST PRODUCTS ARE NOT RECOMMENDED, AUTHORIZED OR WARRANTED FOR USE IN MILITARY, AIR CRAFT, SPACE, LIFE SAVING, OR LIFE SUSTAINING APPLICATIONS, NOR IN PRODUCTS OR SYSTEMS, WHERE FAILURE OR MALFUNCTION MAY RESULT IN PERSONAL INJURY, DEATH, OR SEVERE PROPERTY OR ENVIRONMENTAL DAMAGE. ST PRODUCTS WHICH ARE NOT SPECIFIED AS "AUTOMOTIVE GRADE" MAY ONLY BE USED IN AUTOMOTIVE APPLICATIONS AT USER'S OWN RISK.

Resale of ST products with provisions different from the statements and/or technical features set forth in this document shall immediately void any warranty granted by ST for the ST product or service described herein and shall not create or extend in any manner whatsoever, any liability of ST.

ST and the ST logo are trademarks or registered trademarks of ST in various countries.

Information in this document supersedes and replaces all information previously supplied.

The ST logo is a registered trademark of STMicroelectronics. All other names are the property of their respective owners.

© 2006 STMicroelectronics - All rights reserved

STMicroelectronics group of companies

Australia - Belgium - Brazil - Canada - China - Czech Republic - Finland - France - Germany - Hong Kong - India - Israel - Italy - Japan - Malaysia - Malta - Morocco - Singapore - Spain - Sweden - Switzerland - United Kingdom - United States of America

www.st.com

