

FM IF Amplifier-Limiter, Detector, and Audio Preamplifier

For FM IF Amplifier Applications Up To 20 MHz In
Communications Receivers And High-Fidelity Receivers

Features:

- Good sensitivity: Input limiting voltage (knee) = 250 μ V typ. at 10.7 MHz
- Excellent AM rejection: 55 dB typ. at 10.7 MHz
- Internal Zener diode regulation for the IF amplifier section
- Low harmonic distortion
- Differential peak detection: Permits simplified single-coil tuning
- Audio preamplifier voltage gain: 21 dB typ.
- Minimum number of external parts required

RCA CA3075 is an integrated circuit which provides, in a single monolithic chip, an FM IF subsystem for Communications and High-Fidelity Receivers. This device, shown in the schematic diagram (Fig. 2), consists of a multistage IF amplifier-limiter section with a Zener regulated power supply, an FM detector stage, and an AF preamplifier section. A typical application of the CA3075, in FM receiver circuits, is shown in the block diagram (Fig. 1).

The three-stage, emitter-follower-coupled IF amplifier section provides a 60-dB typ. voltage gain at an operating frequency of 10.7 MHz and features, because of its

transistor constant-current sink, an output stage with exceptionally good limiting characteristics.

The FM detector section, which utilizes a differential-peak-detection circuit, requires only a single coil in the associated outboard detector circuit; hence, tuning the detector circuit is a simple procedure.

The audio preamplifier circuit provides a 21-dB voltage gain with low impedance output for driving subsequent audio amplifier stages.

The CA3075 utilizes a 14-lead dual-in-line plastic package with leads in a special quad-formed arrangement.

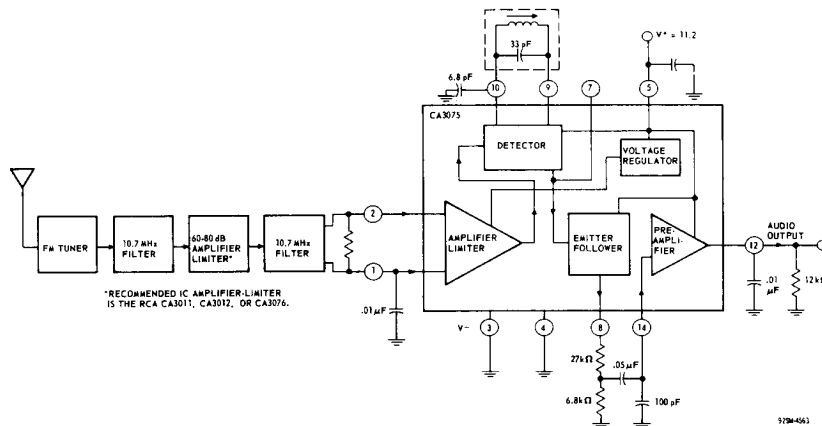

Fig. 1 - Block diagram of typical FM receiver utilizing the CA3075

File Number 429

CA3075

MAXIMUM RATINGS, Absolute-Maximum Values at $T_A = 25^\circ\text{C}$

DC Supply Voltage [between Terminals 5 (V^+) and 3 (V^-)]	12.5	V
DC Current (into Terminal 5)	30	mA
Device Dissipation:		
Up to $T_A = 50^\circ\text{C}$	760	mW
Above $T_A = 50^\circ\text{C}$	derate linearly	7.6 mW/ $^\circ\text{C}$
Ambient Temperature Range:		
Operating	- 40 to + 85	$^\circ\text{C}$
Storage	- 65 to + 150	$^\circ\text{C}$
Lead Temperature (During soldering for 10 s max.)	+ 260	$^\circ\text{C}$

ELECTRICAL CHARACTERISTICS at $T_A = 25^\circ\text{C}$

CHARACTERISTIC	SYMBOL	TEST CONDITIONS	LIMITS			UNITS	TEST CIRCUIT FIG. NO.
			MIN.	TYP.	MAX.		
Static Characteristics							
DC Voltage:							
At Terminal 7	V_7	$V^+ = 11.2\text{V}$	-	6.1	-	V	6
At Terminal 8	V_8		-	5.4	-	V	
At Terminal 12	V_{12}		-	5.2	-	V	
DC Current (into Terminal 5):							
At $V^+ = 8.5\text{V}$	I_5	-	8.5	15	-	mA	6
At $V^+ = 11.2\text{V}$			-	17.5	-	mA	
At $V^+ = 12.5\text{V}$			-	19	29	mA	
Dynamic Characteristics at $V^+ = 11.2$							
IF AMPLIFIER							
Input Limiting Voltage (knee, - 3 dB point)	$V_1(\text{lim})$	$f_0 = 10.7\text{ MHz}$ $f(\text{Modulation}) = 400\text{ Hz}$ Deviation = $\pm 75\text{ kHz}$	-	250	600	μV	3
AM Rejection	AMR	$f_0 = 10.7\text{ MHz}$ $f(\text{Modulation}) = 400\text{ Hz}$ FM: Deviation = $\pm 75\text{ kHz}$ AM: Modulation = 30%	-	55	-	dB	5
Input Impedance Components:							
Parallel Resistance	R_i	$f_0 = 10.7\text{ MHz}$ $V_{\text{IN}} = 10\text{ mV RMS}$	-	4.5	-	$\text{k}\Omega$	-
Parallel Capacitance	C_i		-	4.5	-	pF	
DETECTOR							
Recovered AF Voltage (at Terminal 12)	$V_0(\text{AF})$	$f_0 = 10.7\text{ MHz}$ $f(\text{Modulation}) = 400\text{ Hz}$ Deviation = $\pm 75\text{ kHz}$	-	1.5	-	V	3
Total Harmonic Distortion	THD		-	1	2	%	
AUDIO PREAMPLIFIER							
Voltage Gain	A(AF)	$V_{\text{IN}} = 100\text{ mV}$, $f_0 = 400\text{ Hz}$	-	21	-	dB	4
Total Harmonic Distortion	THD	$V_{\text{OUT}} = 2\text{ V}$, $f_0 = 400\text{ Hz}$	-	1.5	5	%	4

CA3075

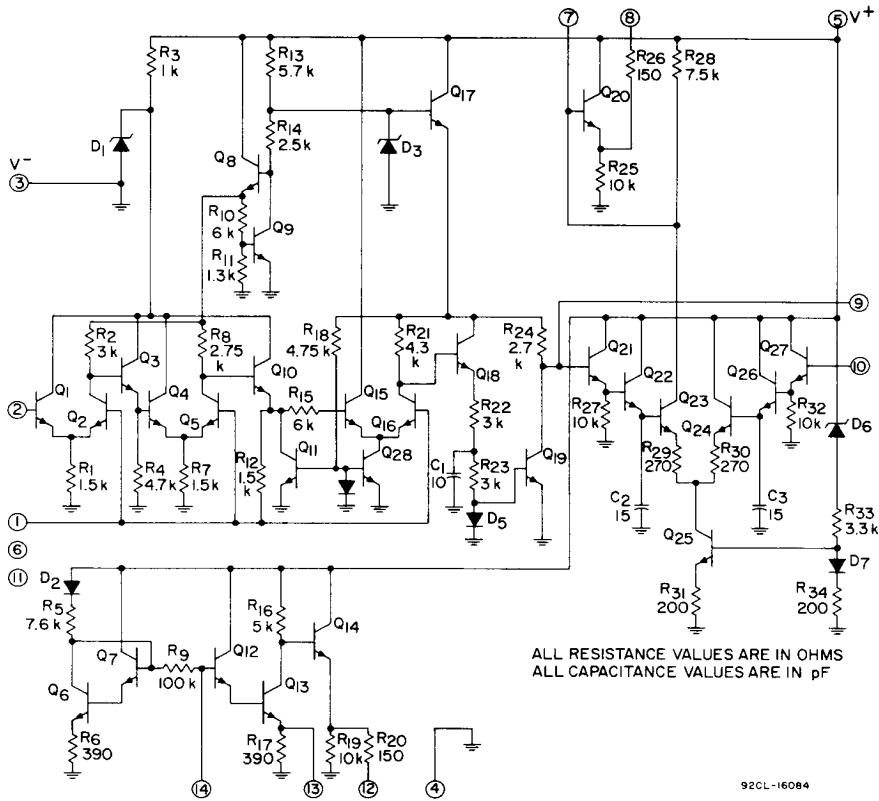

Fig. 2 - Schematic diagram of CA3075

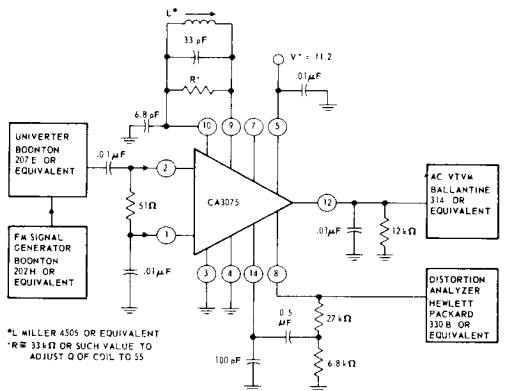

Fig. 3 - Test circuit for input limiting voltage, recovered AF voltage, and total harmonic distortion

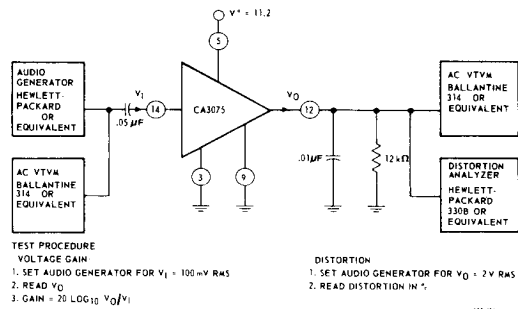

Fig. 4 - Test circuit for audio preamplifier voltage gain and total harmonic distortion

CA3075

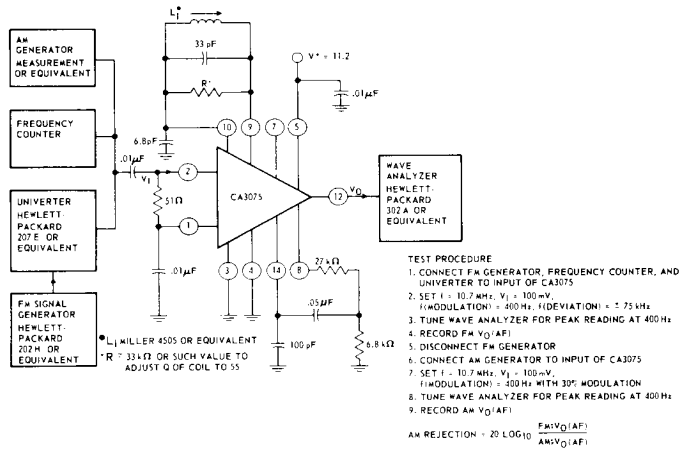

Fig. 5 - Test circuit for AM rejection

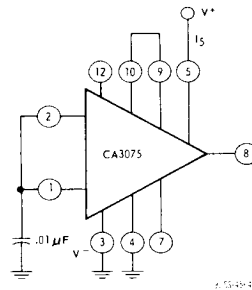
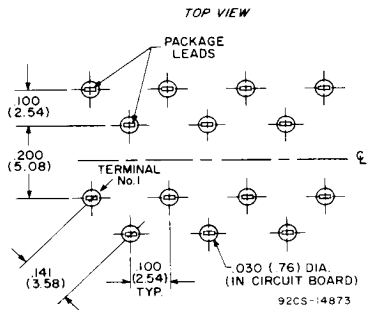

Fig. 6 - Test circuit for static characteristics

Recommended Mounting-Hole Dimensions and Spacings.



Dimensions in parentheses are in millimeters and are derived from the basic inch dimensions as indicated.