



# CAT34RC02

2-kb I<sup>2</sup>C Serial EEPROM, Serial Presence Detect

## FEATURES

- 400 kHz I<sup>2</sup>C bus compatible\*
- 1.7 to 5.5 volt operation
- 16-byte page write buffer
- Hardware write protection for entire memory
- Permanent and reversible software write protection for lower 128 bytes
- Schmitt trigger on SCL and SDA inputs
- Low power CMOS technology
- 1,000,000 program/erase cycles
- 100 year data retention
- 8-pin DIP, SOIC, TSSOP and TDFN packages
- Industrial and extended temperature ranges

## DESCRIPTION

The CAT34RC02 is a 2-kb Serial CMOS EEPROM internally organized as 256 words of 8 bits each. Catalyst's advanced CMOS technology substantially reduces device power requirements. The CAT34RC02 features

a 16-byte page write buffer. The device operates via the I<sup>2</sup>C bus serial interface and is available in 8-pin DIP, SOIC, TSSOP and TDFN packages.

## PIN CONFIGURATION

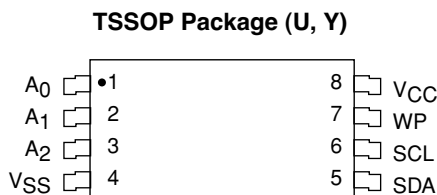
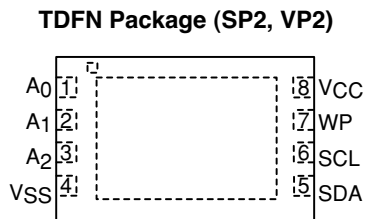
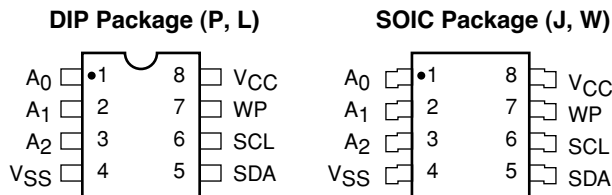

## FUNCTIONAL SYMBOL

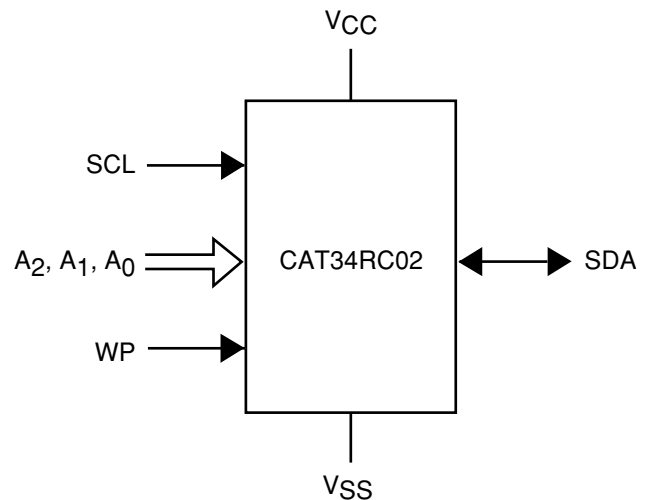

## PIN FUNCTIONS

| Pin Name   | Function                    |
|--|-----------------------------|
| A <sub>0</sub> , A <sub>1</sub> , A <sub>2</sub> | Device Address Inputs       |
| SDA  | Serial Data/Address         |
| SCL  | Serial Clock                |
| WP   | Write Protect               |
| V <sub>CC</sub>                                  | 1.7 V to 5.5 V Power Supply |
| V <sub>SS</sub>                                  | Ground                      |

\* Catalyst Semiconductor is licensed by Philips Corporation to carry the I<sup>2</sup>C Bus Protocol.

**ABSOLUTE MAXIMUM RATINGS\***

Temperature Under Bias ..... -55°C to +125°C  
 Storage Temperature ..... -65°C to +150°C  
 Voltage on Any Pin with  
 Respect to Ground<sup>(1)</sup> ..... -2.0 V to V<sub>CC</sub> + 2.0 V  
 Voltage on A<sub>0</sub> ..... -2.0 V to +12.0 V  
 V<sub>CC</sub> with Respect to V<sub>SS</sub> ..... -2.0 V to +7.0 V

**\*COMMENT**

Stresses above those listed under “Absolute Maximum Ratings” may cause permanent damage to the device. These are stress ratings only, and functional operation of the device at these or any other conditions outside of those listed in the operational sections of this specification is not implied. Exposure to any absolute maximum rating for extended periods may affect device performance and reliability.

**RELIABILITY CHARACTERISTICS**

| Symbol                             | Parameter          | Reference Test Method         | Min       | Units                 |
|------------------------------------|--------------------|-------------------------------|-----------|-----------------------|
| N <sub>END</sub> <sup>(2)(*)</sup> | Endurance          | MIL-STD-883, Test Method 1033 | 1,000,000 | Program/ Erase Cycles |
| T <sub>DR</sub> <sup>(2)(*)</sup>  | Data Retention     | MIL-STD-883, Test Method 1008 | 100       | Years                 |
| V <sub>ZAP</sub> <sup>(2)(*)</sup> | ESD Susceptibility | MIL-STD-883, Test Method 3015 | 4000      | Volts                 |
| I <sub>LTH</sub> <sup>(2)(3)</sup> | Latch-up           | JEDEC Standard 17             | 100       | mA                    |

(\*) Page Mode, V<sub>CC</sub> = 5 V, 25°C

**D.C. OPERATING CHARACTERISTICS**

V<sub>CC</sub> = 1.7 V to 5.5 V, unless otherwise specified.

| Symbol                         | Parameter  | Test Conditions                           | Min                   | Typ | Max                   | Units |
|--------------------------------|--|---|-----------------------|-----|-----------------------|-------|
| I <sub>CC</sub>                | Power Supply Current (Read)  | f <sub>SCL</sub> = 100 kHz                |                       |     | 1                     | mA    |
| I <sub>CC</sub>                | Power Supply Current (Write)   | f <sub>SCL</sub> = 100 kHz                |                       |     | 3                     | mA    |
| I <sub>SB</sub> <sup>(4)</sup> | Standby Current (V <sub>CC</sub> = 5.0 V)                              | V <sub>IN</sub> = GND or V <sub>CC</sub>  |                       |     | 1                     | μA    |
| I <sub>LI</sub>                | Input Leakage Current  | V <sub>IN</sub> = GND to V <sub>CC</sub>  |                       |     | 1                     | μA    |
| I <sub>LO</sub>                | Output Leakage Current   | V <sub>OUT</sub> = GND to V <sub>CC</sub> |                       |     | 1                     | μA    |
| V <sub>IL</sub>                | Input Low Voltage  |   | -1                    |     | V <sub>CC</sub> x 0.3 | V     |
| V <sub>IH</sub>                | Input High Voltage   |   | V <sub>CC</sub> x 0.7 |     | V <sub>CC</sub> + 1.0 | V     |
| V <sub>OL1</sub>               | Output Low Voltage (V <sub>CC</sub> = 3.0 V)                           | I <sub>OL</sub> = 3 mA                    |                       |     | 0.4                   | V     |
| V <sub>OL2</sub>               | Output Low Voltage (V <sub>CC</sub> = 1.7 V)                           | I <sub>OL</sub> = 1.5 mA                  |                       |     | 0.5                   | V     |
| ΔV <sub>HV</sub>               | RSWP Set/Clear Overdrive Voltage, (V <sub>HV</sub> - V <sub>CC</sub> ) | V <sub>CC</sub> > 3.0 V                   | 5.5                   |     |                       | V     |

**CAPACITANCE** T<sub>A</sub> = 25°C, f = 400 kHz, V<sub>CC</sub> = 5 V

| Symbol                          | Test                           | Conditions                              | Min | Typ | Max | Units |
|---------------------------------|--------------------------------|---|-----|-----|-----|-------|
| C <sub>I/O</sub> <sup>(2)</sup> | Input/Output Capacitance (SDA) | V <sub>I/O</sub> = 0 V                  |     |     | 8   | pF    |
| C <sub>IN</sub> <sup>(2)</sup>  | Input Capacitance (other pins) | V <sub>IN</sub> = 0 V                   |     |     | 6   | pF    |
| Z <sub>WPL</sub>                | WP Input Impedance             | V <sub>IN</sub> < 0.5 V                 | 5   |     | 70  | kΩ    |
| Z <sub>WPH</sub>                | WP Input Impedance             | V <sub>IN</sub> > V <sub>CC</sub> x 0.7 | 500 |     |     | kΩ    |

Note:

- (1) The DC input voltage on any pin should not be lower than -0.5 V or higher than V<sub>CC</sub> + 0.5 V. During transitions, the voltage on any pin may undershoot to no less than -2.0 V or overshoot to no more than V<sub>CC</sub> + 2.0 V, for periods of less than 20 ns. The maximum DC voltage on address pin A<sub>0</sub> is +12.0 V.
- (2) This parameter is tested initially and after a design or process change that affects the parameter.
- (3) Latch-up protection is provided for stresses up to 100 mA on I/O pins from -1.0 V to V<sub>CC</sub> + 1.0 V.
- (4) Standby Current, I<sub>SB</sub> = 10 μA max at extended temperature range.

**A.C. CHARACTERISTICS**

$V_{CC} = 1.7\text{ V}$  to  $5.5\text{ V}$ , unless otherwise specified.

**Read & Write Cycle Limits**

| Symbol          | Parameter   | 1.7 V - 5.5 V |     | 2.5 V - 5.5 V |     | Units         |
|-----------------|---|---------------|-----|---------------|-----|---------------|
|                 |   | Min           | Max | Min           | Max |               |
| $F_{SCL}$       | Clock Frequency   |               | 100 |               | 400 | kHz           |
| $T_I^{(1)}$     | Noise Suppression Time Constant at SCL, SDA Inputs            |               | 100 |               | 100 | ns            |
| $t_{AA}$        | SCL Low to SDA Data Out and ACK Out                           |               | 3.5 |               | 0.9 | $\mu\text{s}$ |
| $t_{BUF}^{(1)}$ | Time the Bus Must be Free Before a New Transmission Can Start | 4.7           |     | 1.3           |     | $\mu\text{s}$ |
| $t_{HD:STA}$    | Start Condition Hold Time                                     | 4             |     | 0.6           |     | $\mu\text{s}$ |
| $t_{LOW}$       | Clock Low Period  | 4.7           |     | 1.3           |     | $\mu\text{s}$ |
| $t_{HIGH}$      | Clock High Period   | 4             |     | 0.6           |     | $\mu\text{s}$ |
| $t_{SU:STA}$    | Start Condition Setup Time (for a Repeated Start Condition)   | 4.7           |     | 0.6           |     | $\mu\text{s}$ |
| $t_{HD:DAT}$    | Data In Hold Time   | 0             |     | 0             |     | ns            |
| $t_{SU:DAT}$    | Data In Setup Time  | 250           |     | 100           |     | ns            |
| $t_R^{(1)}$     | SDA and SCL Rise Time   |               | 1   |               | 0.3 | $\mu\text{s}$ |
| $t_F^{(1)}$     | SDA and SCL Fall Time   |               | 300 |               | 300 | ns            |
| $t_{SU:STO}$    | Stop Condition Setup Time                                     | 4             |     | 0.6           |     | $\mu\text{s}$ |
| $t_{DH}$        | Data Out Hold Time  | 100           |     | 100           |     | ns            |

**Power-Up Timing<sup>(1)(2)</sup>**

| Symbol    | Parameter                   | Min | Typ | Max | Units |
|-----------|-----------------------------|-----|-----|-----|-------|
| $t_{PUR}$ | Power-up to Read Operation  |     |     | 1   | ms    |
| $t_{PUW}$ | Power-up to Write Operation |     |     | 1   | ms    |

**Write Cycle Limits**

| Symbol   | Parameter        | Min | Typ | Max | Units |
|----------|------------------|-----|-----|-----|-------|
| $t_{WR}$ | Write Cycle Time |     |     | 5   | ms    |

The write cycle time is the time elapsed between the STOP command (following the write instruction) and the completion of the internal write cycle. During the internal

write cycle, SDA is released by the Slave and the device does not acknowledge external commands.

Note:

- (1) This parameter is tested initially and after a design or process change that affects the parameter.  
 (2)  $t_{PUR}$  and  $t_{PUW}$  are the delays required from the time  $V_{CC}$  is stable until the specified operation can be initiated.

## FUNCTIONAL DESCRIPTION

The CAT34RC02 supports the I<sup>2</sup>C (2-wire) Bus data transmission protocol. This Inter-Integrated Circuit Bus protocol defines any device that sends data to the bus to be a transmitter and any device receiving data to be a receiver. Data transfer is controlled by the Master device which generates the serial clock and all START and STOP conditions for bus access. The CAT34RC02 operates as a Slave device. Both the Master and Slave devices can operate as either transmitter or receiver, but the Master alone assigns those roles. A maximum of 8 devices may be connected to the bus as determined by the device address inputs A<sub>0</sub>, A<sub>1</sub>, and A<sub>2</sub>.

## PIN DESCRIPTIONS

### SCL: Serial Clock

The serial clock input pin is used to clock all data transfers into or out of the device.

### SDA: Serial Data/Address

The bidirectional serial data/address pin is used to transfer data into and out of the device. This pin is an open drain output in transmit mode.

### A<sub>0</sub>, A<sub>1</sub>, A<sub>2</sub>: Device Address Inputs

These inputs set the device address. When left floating, the address pins are internally pulled to ground.

### WP: Write Protect

This input, when grounded or left floating, allows write operations to the entire memory. When this pin is tied to V<sub>CC</sub>, the entire memory is write protected.

Figure 1. Bus Timing

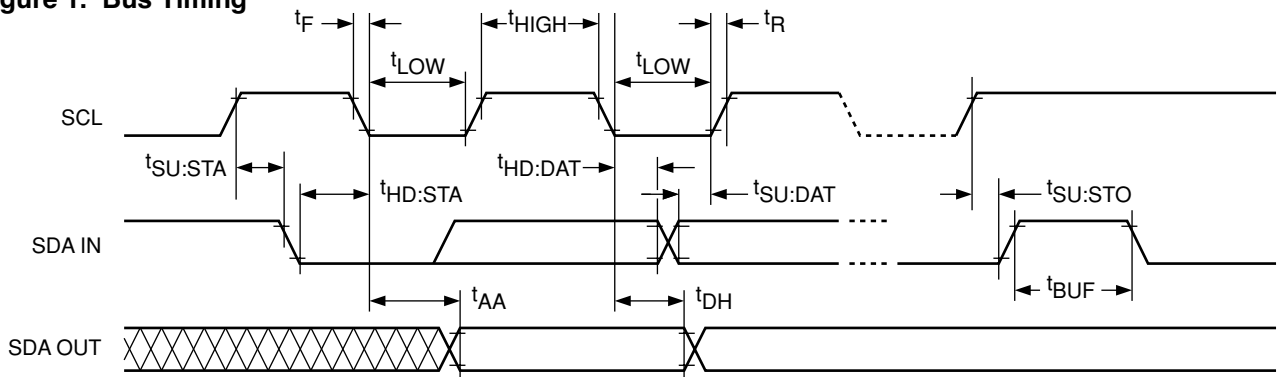

Figure 2. Write Cycle Timing

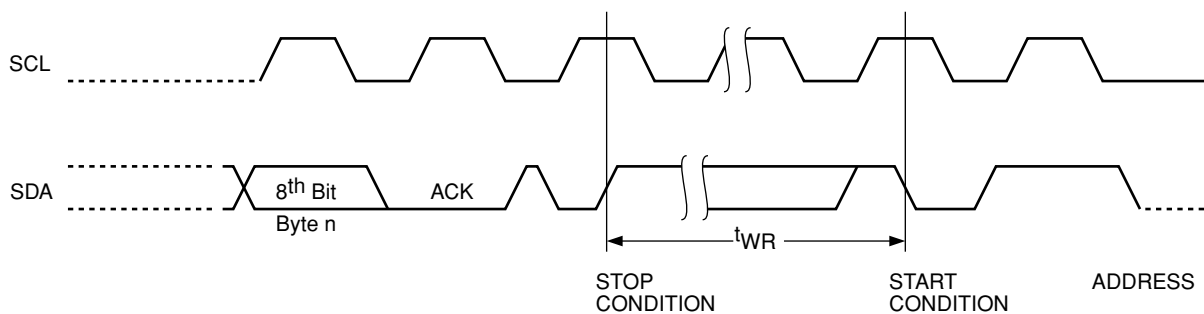
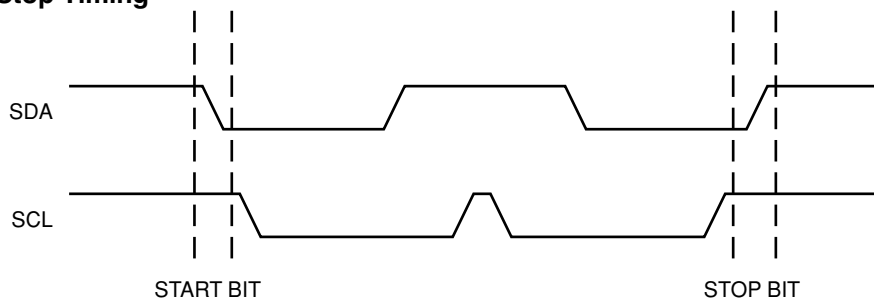

Figure 3. Start/Stop Timing



## I<sup>2</sup>C BUS PROTOCOL

The I<sup>2</sup>C bus consists of two 'wires', SCL and SDA. The two 'wires' are connected to the supply (V<sub>CC</sub>) via pull-up resistors. Master and Slave devices connect to the bus via their respective SCL and SDA pins. The transmitting device pulls down the SDA line to 'transmit' a '0' and releases it to 'transmit' a '1'.

- (1) Data transfer may be initiated only when the bus is not busy (see A.C. Characteristics).
- (2) During a data transfer, the data line must remain stable whenever the SCL line is high. An SDA transition while SCL is high will be interpreted as a START or STOP condition.

### START Condition

The START Condition precedes all commands. It consists of a HIGH to LOW transition on SDA while SCL is HIGH. The START condition acts as a 'wake-up' call for the Slave devices. A Slave will not respond to commands unless the MASTER generates a START condition.

### STOP Condition

The STOP condition completes all commands. It consists of a LOW to HIGH transition on SDA while SCL is HIGH. The STOP condition starts the internal write cycle, when following a WRITE command and sends the Slave into standby mode, when following a READ command.

## Device Addressing

The Master initiates a data transfer by creating a START condition on the bus. The Master then broadcasts an 8-bit serial Slave address. The four most significant bits of the Slave address (the 'preamble') are fixed to 1010 (Ah), for normal read/write operations and 0110 (6h) for Software Write Protect (SWP) operations (Fig. 5). The next three bits, A<sub>2</sub>, A<sub>1</sub> and A<sub>0</sub>, select one of eight possible Slave devices. The last bit, R/W, specifies whether a Read (1) or Write (0) operation is to be performed.

### Acknowledge

After processing the Slave address, the Slave responds with an acknowledge (ACK) by pulling down the SDA line during the 9<sup>th</sup> clock cycle. The Slave will also acknowledge the 8-bit byte address and every data byte presented in WRITE mode. In READ mode the Slave shifts out eight bits of data, and then 'releases' the SDA line during the 9<sup>th</sup> clock cycle. If the Master acknowledges in the 9<sup>th</sup> clock cycle (by pulling down the SDA line), then the Slave continues transmitting. When data transfer is complete, the Master responds with a NoACK (it does not acknowledge the last data byte) and the Slave stops transmitting and waits for a STOP condition.

Figure 4. Acknowledge Timing

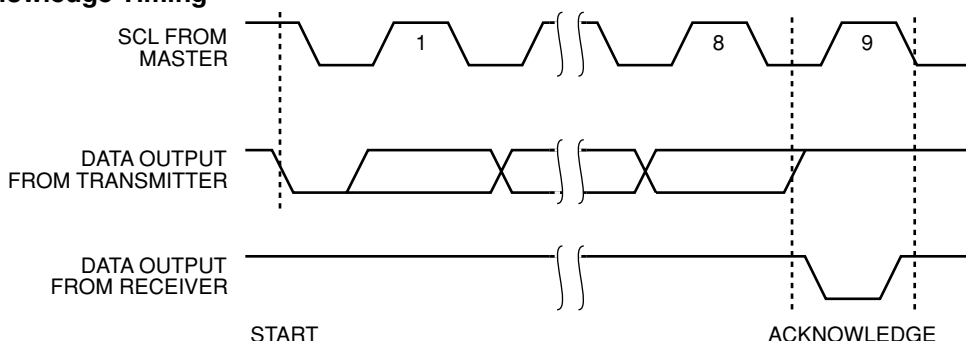
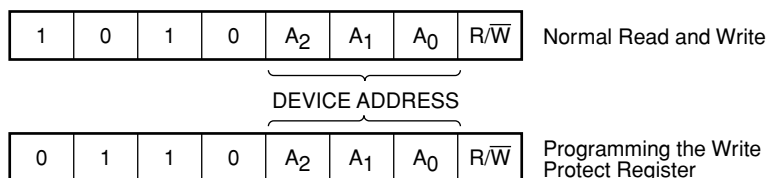

Figure 5. Slave Address Bits



## WRITE OPERATIONS

### Byte Write

In Byte Write mode the Master creates a START condition, and then broadcasts the Slave address, byte address and data to be written. The Slave acknowledges the three bytes by pulling down the SDA line during the 9<sup>th</sup> clock cycle following each byte. The Master creates a STOP condition after the last ACK from the Slave, which then starts the internal write operation (Fig. 6). During internal write, the Slave will ignore any read/write request from the Master.

### Page Write

The CAT34RC02 contains 256 bytes of data, arranged in 16 pages of 16 bytes each. The page is selected by the four most significant bits of the address byte presented to the device after the Slave address, while the four least significant bits point to the byte within the page. By 'loading' more than one data byte into the device, up to an entire page can be written in one write cycle (Fig. 7). The internal byte address counter will increment after each data byte. If the Master transmits more than 16 data bytes, then earlier bytes will be overwritten by later bytes in a 'wrap-around' fashion within the selected page. The internal write cycle is started following the STOP condition created by the Master.

### Acknowledge Polling

Acknowledge polling can be used to determine if the CAT34RC02 is busy writing or is ready to accept commands. Polling is implemented by sending a 'Selective Read' command (described under READ OPERATIONS) to the device. The CAT34RC02 will

acknowledge the Slave address, as long as internal write is in progress.

## WRITE PROTECTION

### Hardware Write Protection

With the WP pin held HIGH, the entire memory, as well as the SWP flags are protected against WRITE operations (Fig. 9). If the WP pin is left floating or is grounded, then it has no impact on the operation of the CAT34RC02.

### Software Write Protection

The lower half of memory (first 128 bytes) can be protected against WRITE operations by setting one of two Software Write Protection (SWP) flags/switches. The PSWP (Permanent Software Write Protection) flag can be set but not cleared by the user. The RSWP (Reversible Software Write Protection) flag can be set and cleared by the user. Whereas the PSWP flag can be set 'in-system', the RSWP flag is meant to be used during testing. RSWP commands require the presence of a very high voltage (higher than VCC) on address pin A<sub>0</sub> and fixed logic levels for the other two address pins.

The CAT34RC02 is shipped 'unprotected'. The state of the SWP flags can be read by issuing an 'Immediate Address Read' command, with the Slave address 'preamble' set to 0110 (6h) instead of the 'normal' 1010 (Ah). A SWP READ will return the complemented versions of the two flags in the last two slots of the resulting data byte; the other six more significant bits in the data byte have no meaning to the user (Fig. 11).

Figure 6. Byte Write Timing

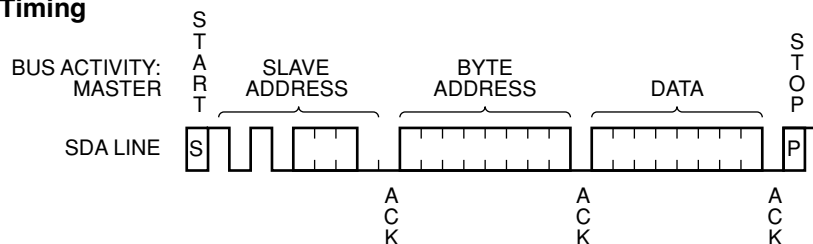
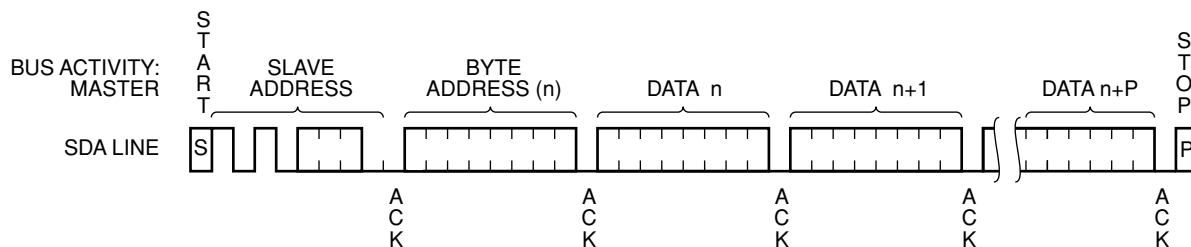

Figure 7. Page Write Timing



NOTE: IN THIS EXAMPLE n = XXXX 0000(B); X = 1 or 0

The PSWP flag can be set (forever) by issuing a 'Byte Write' command, with the Slave address preamble set to '6h', followed by a 'don't care' address, followed by 'don't care' data and a STOP condition. The CAT34RC02 will acknowledge the Slave address, dummy byte address and dummy data (Fig. 10). The PSWP flag will be permanently set (after the internal write cycle is completed).

The SWP commands are shown in Table 1.

**Table 1. SWP Commands**

| Command    | PIN |    |     | Slave Address |    |    |    |                |    |    |     |
|------------|-----|----|-----|---------------|----|----|----|----------------|----|----|-----|
|            | A2  | A1 | A0  | Preamble      |    |    |    | Device Address |    |    | R/W |
|            | B7  | B6 | B5  | B4            | B3 | B2 | B1 | B0             |    |    |     |
| SWP READ   | A2  | A1 | A0  | 0             | 1  | 1  | 0  | A2             | A1 | A0 | 1   |
| RSWP SET   | 0   | 0  | VHV | 0             | 1  | 1  | 0  | 0              | 0  | 1  | 0   |
| RSWP CLEAR | 0   | 1  | VHV | 0             | 1  | 1  | 0  | 0              | 1  | 1  | 0   |
| PSWP SET   | A2  | A1 | A0  | 0             | 1  | 1  | 0  | A2             | A1 | A0 | 0   |

The CAT34RC02 will not acknowledge RSWP or PSWP commands, once the PSWP flag is set. If the PSWP flag is not set, but the WP pin is HIGH, then the CAT34RC02 will react to RSWP or PSWP commands as follows: if the command attempts to 'flip' one of the two SWP switches, then the CAT34RC02 will respond the same way the regular memory would, i.e. the command and address (in this case dummy) are acknowledged, but the data (in this case dummy) will not be acknowledged; if the

command attempts to 'reaffirm' one of the two switches, then the CAT34RC02 will not acknowledge the command itself. In addition, the CAT34RC02 will not acknowledge a 'reaffirming' SWP command, even if the WP pin is LOW.

## READ OPERATIONS

### Immediate Address Read

In standby mode, the CAT34RC02 internal address counter points to the data byte immediately following the last byte accessed by a previous operation. If the 'previous' byte was the last byte in memory, then the address counter will point to the first memory byte, etc. If the CAT34RC02 decodes a Slave address with a '1' in the R/W bit position (Fig. 8), it will issue an ACK in the 9<sup>th</sup> clock cycle, and will then transmit the data byte being pointed at by the address counter. The Master can then stop further transmission by issuing a NoACK, followed by a STOP condition.

### Selective Read

The READ operation can also be started at an address different from the one stored in the address counter. The address counter can be 'initialized' by performing a 'dummy' WRITE operation (Fig. 12). The START condition is followed by the Slave address (with the R/W bit set to '0') and the desired byte address. Instead of following up with data, the Master then issues a 2<sup>nd</sup> START, followed by the 'Immediate Address Read' sequence, as described earlier.

### Sequential Read

If the Master acknowledges the 1<sup>st</sup> data byte transmitted

**Figure 8. Immediate Address Read Timing**

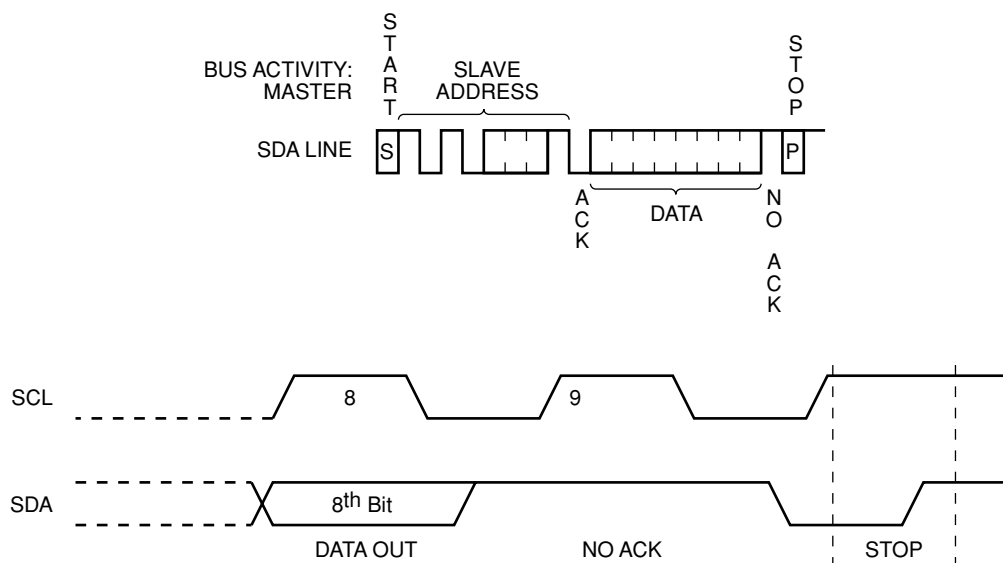

by the CAT34RC02, then the device will continue transmitting as long as each data byte is acknowledged by the Master (Fig. 13). If the end of memory is reached during sequential READ, the address counter will 'wrap-around' to the beginning of memory, etc. Sequential READ works with either 'Immediate Address Read' or 'Selective Read', the only difference being the starting byte address.

Figure 9. Memory Array

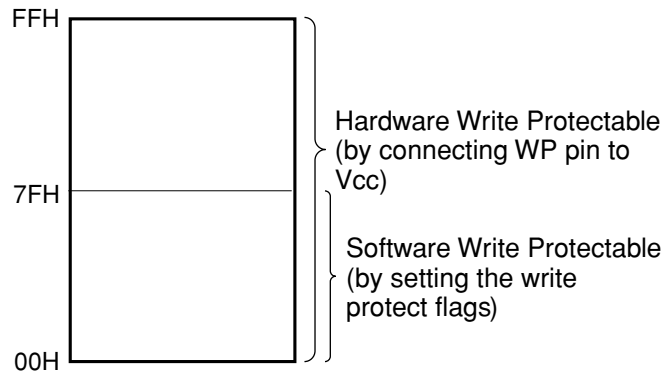
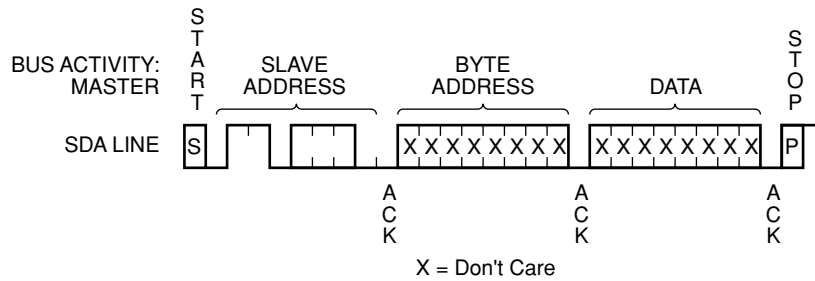

Figure 10. Software Write Protect (Write)



\* For PSWP  $A_0$  is at normal CMOS levels and for RSWP,  $A_0$  is at  $V_{HV}$  which must be held high beyond the end of the STOP condition (approximately  $1\mu s$  of "overlap" is sufficient).



Figure 11. Software Write Protect (Read)

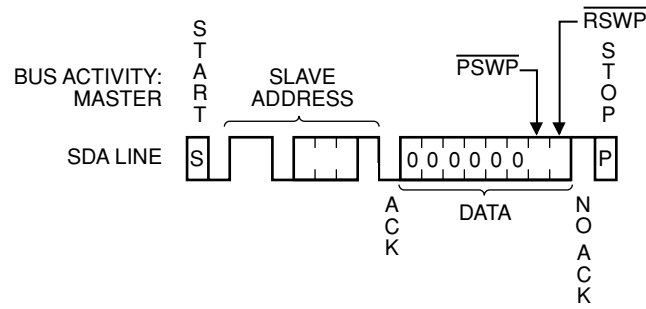

Figure 12. Selective Read Timing

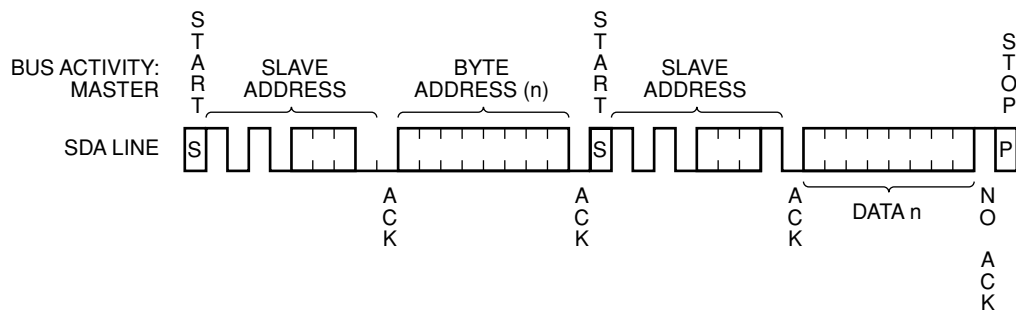
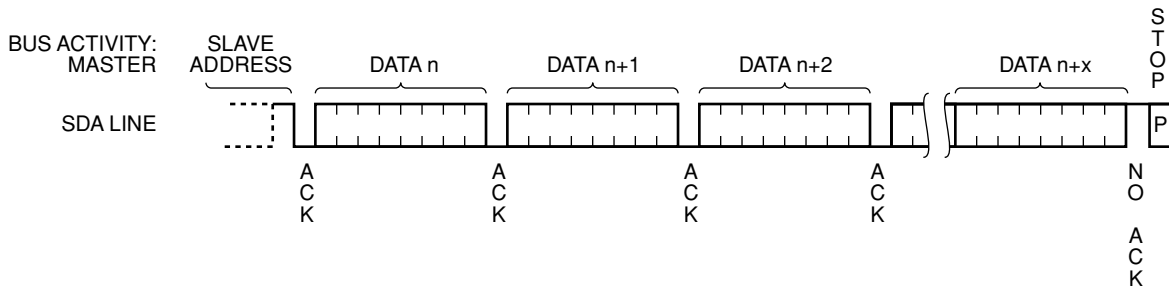
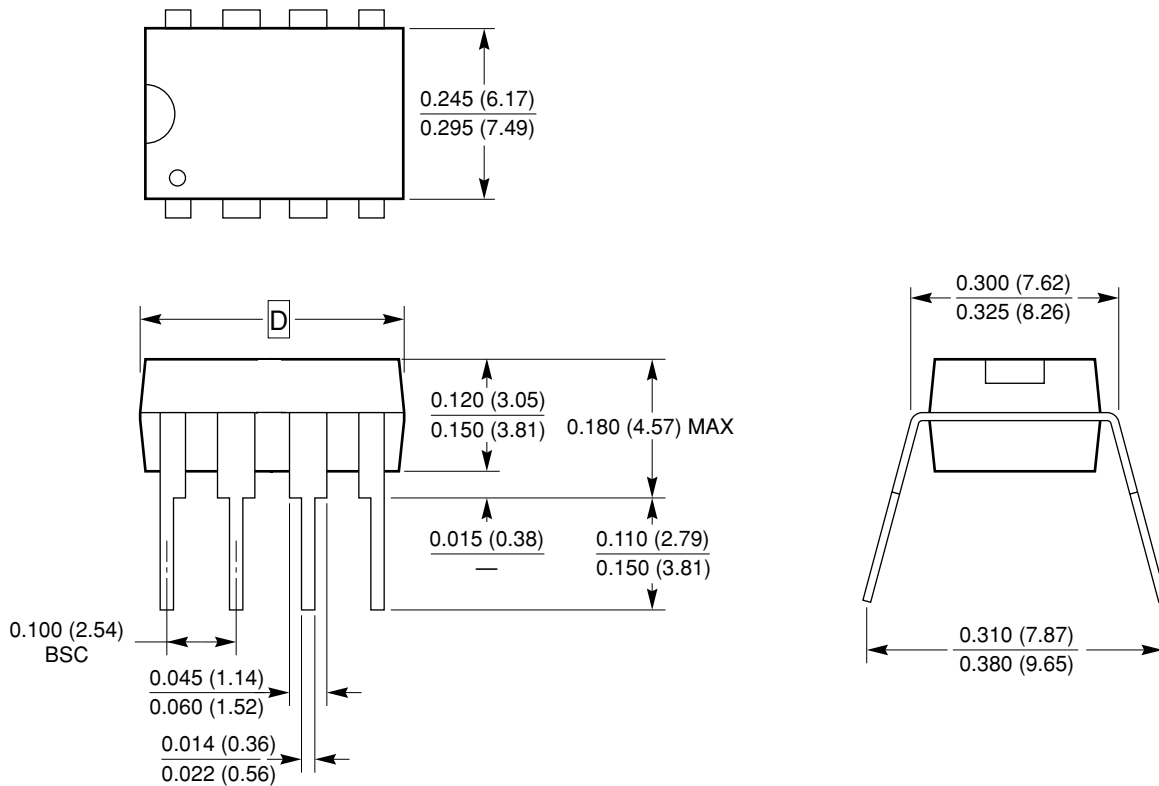

Figure 13. Sequential Read Timing



8-22-LEAD 300 MIL WIDE PLASTIC DIP (P, L)



| Dimension D |              |               |
|-------------|--------------|---------------|
| Pkg         | Min          | Max           |
| 8L          | 0.355 (9.02) | 0.400 (10.16) |

Notes:

1. Complies with JEDEC Publication 95 MS001 dimensions; however, some of the dimensions may be more stringent.
2. All linear dimensions are in inches and parenthetically in millimeters.

8-LEAD 150 MIL WIDE SOIC (J, W)

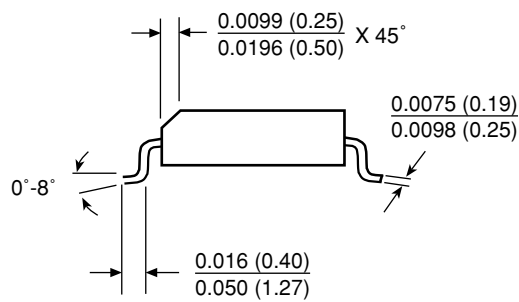
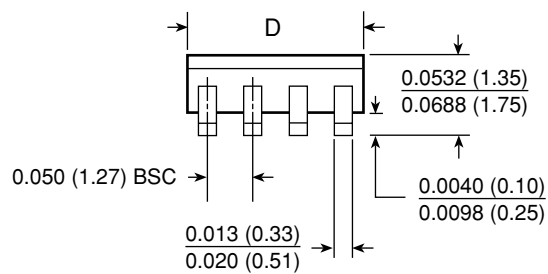
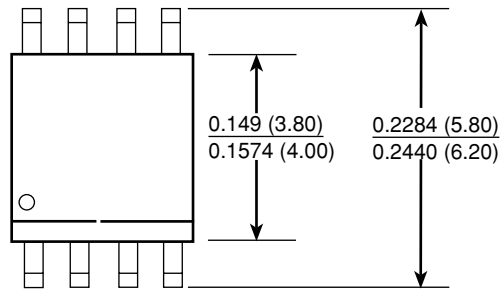

| Dimension D |              |              |
|-------------|--------------|--------------|
| Pkg         | Min          | Max          |
| 8L          | 0.1890(4.80) | 0.1968(5.00) |

Notes:

1. Complies with JEDEC publication 95 MS-012 dimensions; however, some dimensions may be more stringent.
2. All linear dimensions are in inches and parenthetically in millimeters.
3. Lead coplanarity is 0.004" (0.102mm) maximum.

8-PAD TDFN 2X3 PACKAGE (VP2, SP2)

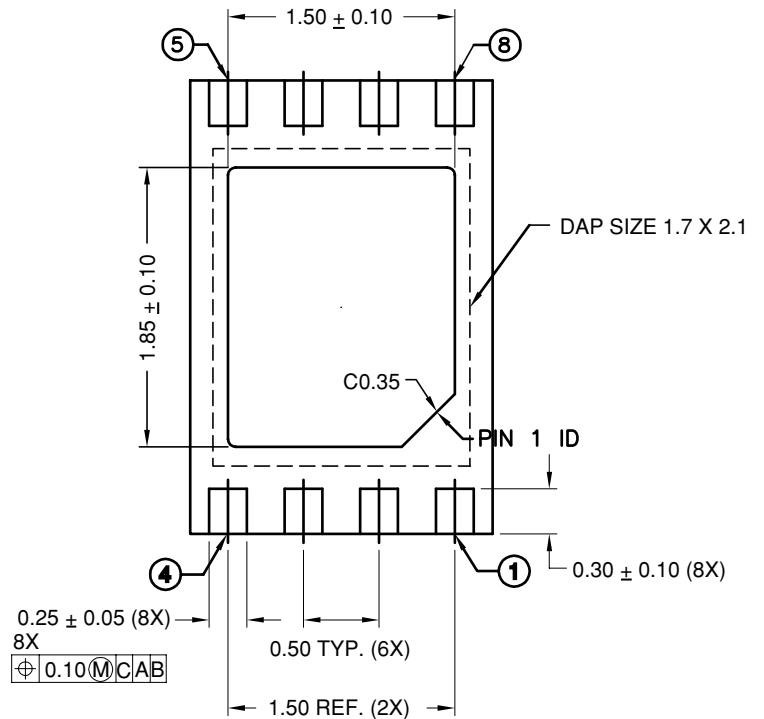
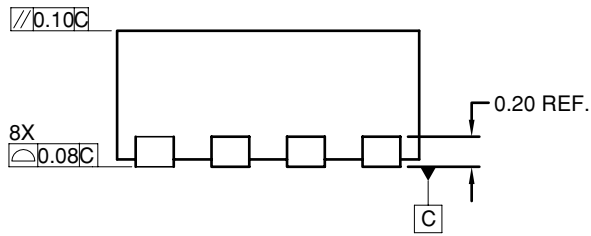
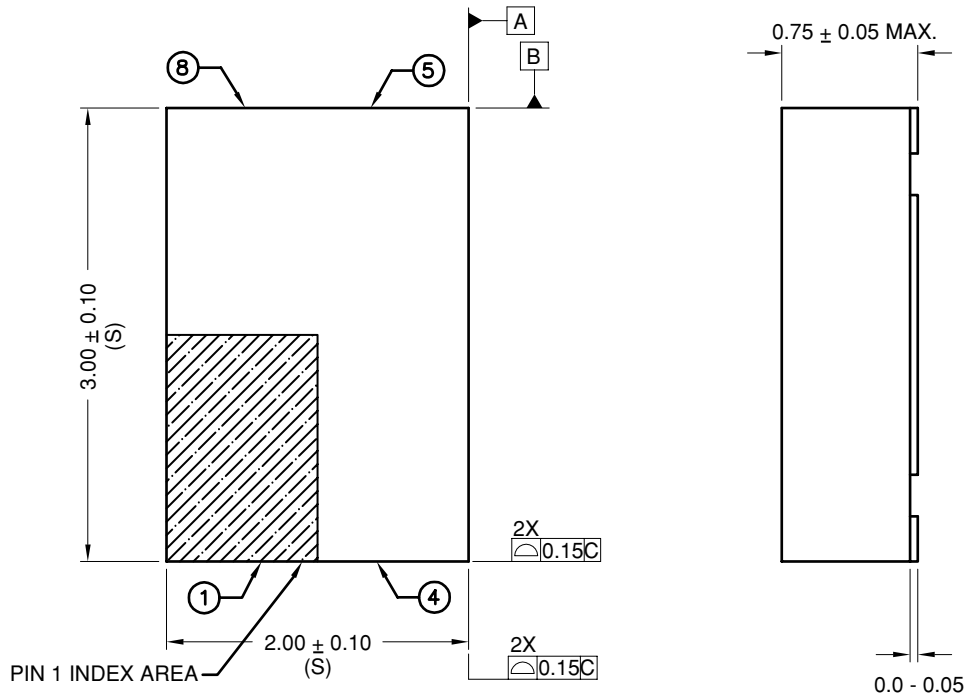

NOTE:

1. ALL DIMENSIONS IN MM. ANGLES IN DEGREES.
2. COPLANARITY APPLIES TO THE EXPOSED PAD AS WELL AS THE TERMNALS. COPLANARITY SHALL NOT EXCEED 0.08 MM.
3. WARPAGE SHALL NOT EXCEED 0.10 MM.
4. PACKAGE LENGTH / PACKAGE WIDTH ARE NOT CONSIDERED AS SPECIAL CHARACTERISTIC.

### 8-LEAD TSSOP (U, Y)

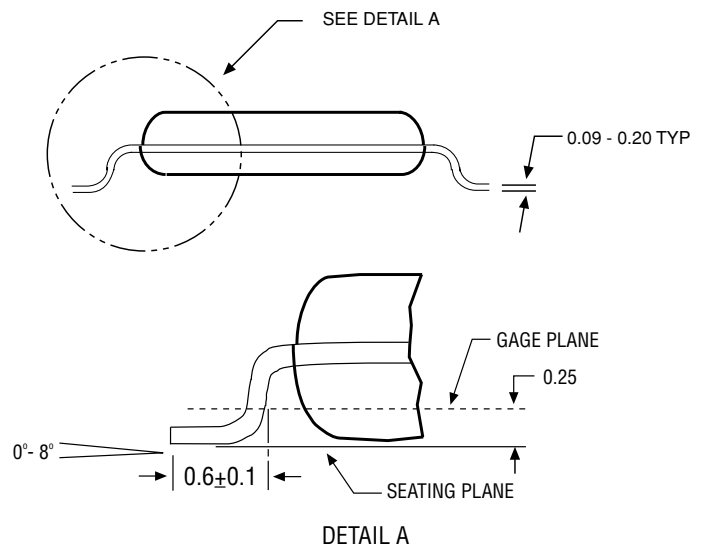
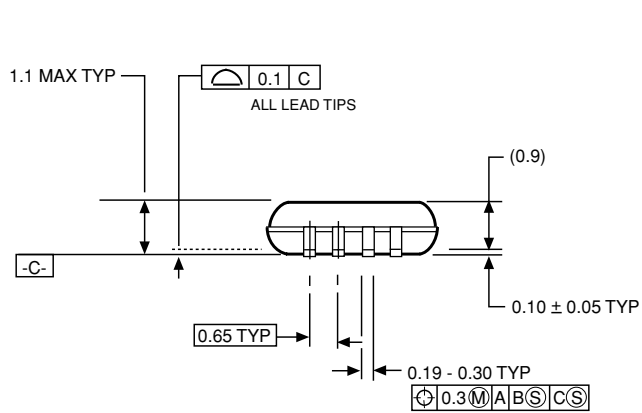
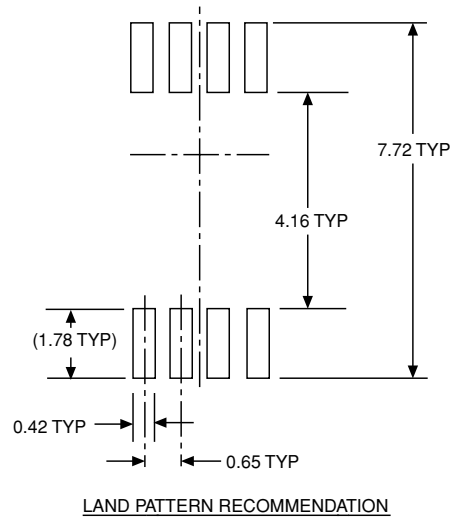
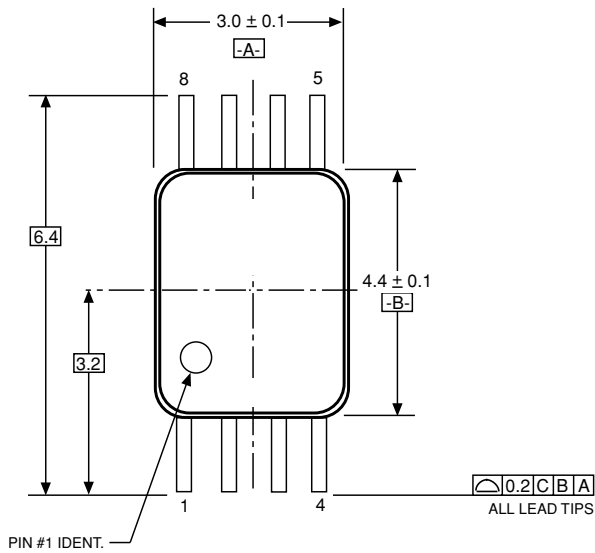

Notes:

- Lead coplanarity is 0.004" (0.102mm) maximum.

**ORDERING INFORMATION**

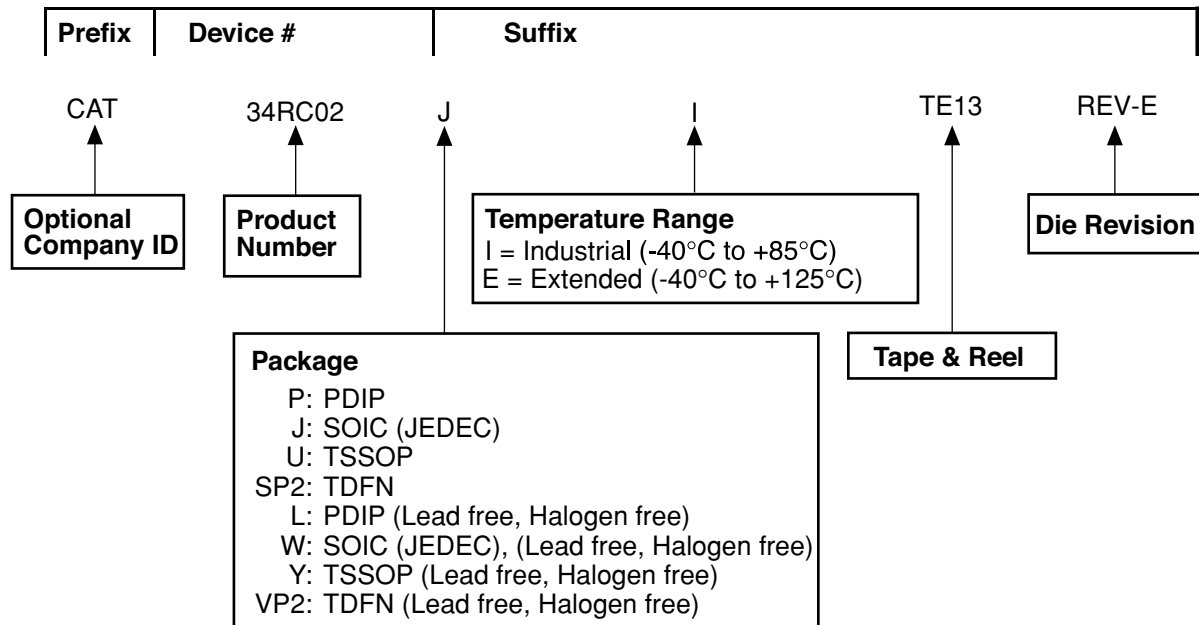

**Notes:**

(1) The device used in the above example is a 34RC02JI-TE13 (SOIC, Industrial Temperature, 1.7 Volt to 5.5 Volt Operating Voltage, Tape & Reel)

**REVISION HISTORY**

| <b>Date</b> | <b>Revision</b> | <b>Comments</b>   |
|-------------|-----------------|---|
| 09/22/03    | A               | Initial Issue   |
| 12/09/03    | B               | Removed Automotive temperature range<br>Changed Industrial Temp to “ I” from “ Blank” in ordering information   |
| 01/12/04    | C               | Updated Features<br>Replaced Block Diagram with Functional Symbol<br>Updated Notes for Reliability Characteristics, D.C. Operating Characteristics and Capacitance<br>Updated TDFN package<br>Updated packaging information to reflect new TDFN package |
| 02/20/04    | D               | Re-labeled TDFN package to A0, A1, A2 instead of A1, A2, A3   |
| 03/22/04    | E               | Updated Absolute Max. Ratings<br>Updated DC Operating Characteristics<br>Updated Table 1 (SWP Commands)<br>Updated Fig 11<br>Added mechanical package drawings<br>Corrected TDFN drawing  |
| 03/31/04    | F               | Corrected table 1 SWP Commands  |
| 05/16/04    | G               | Update D.C. Operating Characteristics<br>Update Write Cycle Limits<br>Update Revision History<br>Update Rev Number  |
| 06/03/04    | H               | Update Die Revision in Ordering Information<br>Eliminate data sheet designation<br>Updated DC Operating Characteristics   |
| 06/07/04    | I               | Updated Write Cycle Limits  |

---

**Copyrights, Trademarks and Patents**

Trademarks and registered trademarks of Catalyst Semiconductor include each of the following:

DPP™ DPPs™ AE<sup>2</sup>™

Catalyst Semiconductor has been issued U.S. and foreign patents and has patent applications pending that protect its products. For a complete list of patents issued to Catalyst Semiconductor contact the Company's corporate office at 408.542.1000.

*CATALYST SEMICONDUCTOR MAKES NO WARRANTY, REPRESENTATION OR GUARANTEE, EXPRESS OR IMPLIED, REGARDING THE SUITABILITY OF ITS PRODUCTS FOR ANY PARTICULAR PURPOSE, NOR THAT THE USE OF ITS PRODUCTS WILL NOT INFRINGE ITS INTELLECTUAL PROPERTY RIGHTS OR THE RIGHTS OF THIRD PARTIES WITH RESPECT TO ANY PARTICULAR USE OR APPLICATION AND SPECIFICALLY DISCLAIMS ANY AND ALL LIABILITY ARISING OUT OF ANY SUCH USE OR APPLICATION, INCLUDING BUT NOT LIMITED TO, CONSEQUENTIAL OR INCIDENTAL DAMAGES.*

Catalyst Semiconductor products are not designed, intended, or authorized for use as components in systems intended for surgical implant into the body, or other applications intended to support or sustain life, or for any other application in which the failure of the Catalyst Semiconductor product could create a situation where personal injury or death may occur.

Catalyst Semiconductor reserves the right to make changes to or discontinue any product or service described herein without notice. Products with data sheets labeled "Advance Information" or "Preliminary" and other products described herein may not be in production or offered for sale.

Catalyst Semiconductor advises customers to obtain the current version of the relevant product information before placing orders. Circuit diagrams illustrate typical semiconductor applications and may not be complete.

---



**CATALYST**

Catalyst Semiconductor, Inc.  
Corporate Headquarters  
1250 Borregas Avenue  
Sunnyvale, CA 94089  
Phone: 408.542.1000  
Fax: 408.542.1200  
[www.catalyst-semiconductor.com](http://www.catalyst-semiconductor.com)

Publication #: 1052  
Revision: I  
Issue date: 06/07/04



This datasheet has been download from:

[www.datasheetcatalog.com](http://www.datasheetcatalog.com)

Datasheets for electronics components.