



## 32-Tap Digitally Programmable Potentiometer (DPP™)

### FEATURES

- 32-position linear taper potentiometer
- Non-volatile EEPROM wiper storage
- Low standby current
- Single supply operation: 2.5V – 5.5V
- Increment Up/Down serial interface
- Resistance values: 10kΩ, 50kΩ and 100kΩ
- CAT5127 in tiny 8 lead 2mmx2.5mm TDFN and MSOP packages
- CAT5129 in the 6 lead TSOT23 package

### APPLICATION

- Automated product calibration
- Remote control adjustments
- Offset, gain and zero control
- Tamper-proof calibrations
- Contrast, brightness and volume controls
- Motor controls and feedback systems
- Programmable analog functions

For Ordering Information details, see page 11.

### DESCRIPTION

The CAT5127/CAT5129 are single digitally programmable potentiometers (DPP™) designed as a electronic replacement for mechanical potentiometers and trim pots. Ideal for automated adjustments on high volume production lines, they are also well suited for applications where equipment requiring periodic adjustment is either difficult to access or located in a hazardous or remote environment.

The CAT5127 contains a 32-tap series resistor array connected between two terminals  $R_H$  and  $R_L$ . The CAT5129 contains a 32-tap series resistor array connected between two terminals  $R_H$  and GND. An up/down counter and decoder that are controlled by three input pins, determines which tap is connected to the wiper. The wiper setting, stored in nonvolatile memory, is not lost when the device is powered down and is automatically reinstated when power is returned. The wiper can be adjusted to test new system values without effecting the stored setting. Wiper-control of the CAT5127/CAT5129 is accomplished with three input control pins,  $\overline{CS}$ ,  $U/\overline{D}$ , and  $\overline{INC}$ . The  $\overline{INC}$  input increments the wiper in the direction which is determined by the logic state of the  $U/\overline{D}$  input. The  $\overline{CS}$  input is used to select the device and also store the wiper position prior to power down.

The devices are used as two-terminal variable resistors. DPPs bring variability and programmability to a wide variety of applications including control, parameter adjustments, and signal processing.

### FUNCTIONAL DIAGRAM

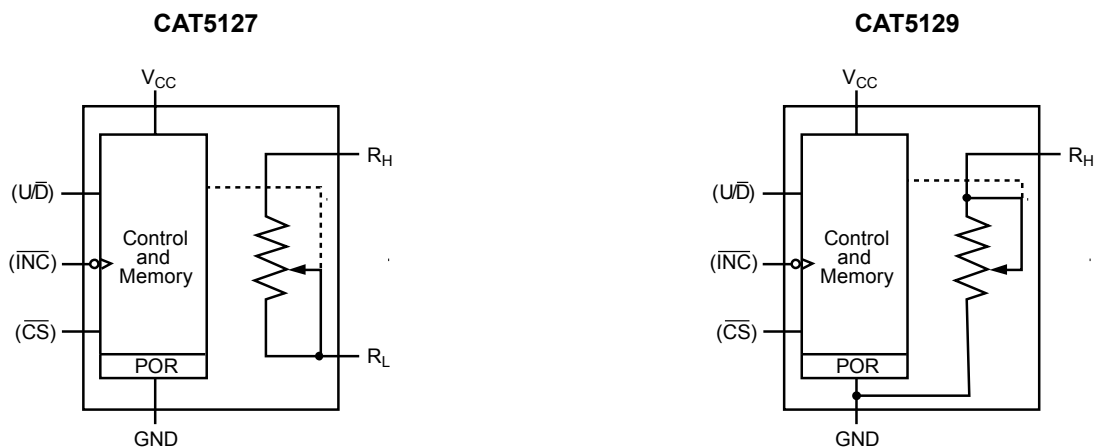

## PIN CONFIGURATION

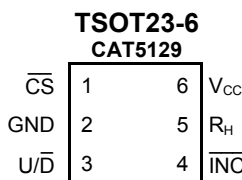
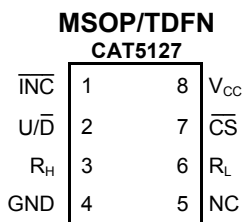

## PIN DESCRIPTIONS

Name	Function	CAT5127 MSOP/TDFN	CAT5129 SOT23
$\overline{\text{INC}}$	Increment Control	1	4
$\text{U}/\overline{\text{D}}$	Up/Down Control	2	3
$R_{\text{H}}$	Potentiometer High	3	5
GND	Ground	4	2
NC	No Connect	5	-
$R_{\text{L}}$	Potentiometer Low	6	-
$\overline{\text{CS}}$	Chip Select	7	1
$V_{\text{CC}}$	Supply Voltage	8	6

## DEVICE DESCRIPTION

### $\overline{\text{INC}}$ : Increment Control Input

The  $\overline{\text{INC}}$  input moves the wiper in the up or down direction determined by the condition of the  $\text{U}/\overline{\text{D}}$  input.

### $\text{U}/\overline{\text{D}}$ : Up/Down Control Input

The  $\text{U}/\overline{\text{D}}$  input controls the direction of the wiper movement. When in a high state and  $\overline{\text{CS}}$  is low, any high-to-low transition on  $\overline{\text{INC}}$  will cause the wiper to move one increment toward the  $R_{\text{H}}$  terminal. When in a low state and  $\overline{\text{CS}}$  is low, any high-to-low transition on  $\overline{\text{INC}}$  will cause the wiper to move one increment towards the  $R_{\text{L}}$  terminal.

### $R_{\text{H}}$ : High End Potentiometer Terminal

$R_{\text{H}}$  is the high end terminal of the potentiometer. It is not required that this terminal be connected to a potential greater than the  $R_{\text{L}}$  terminal. Voltage applied to the  $R_{\text{H}}$  terminal cannot exceed the supply voltage,  $V_{\text{CC}}$  or go below ground, GND.

### $R_{\text{L}}$ : Low End Potentiometer Terminal (CAT5127 only)

$R_{\text{L}}$  is the low end terminal of the potentiometer. It is not required that this terminal be connected to a potential less than the  $R_{\text{H}}$  terminal. Voltage applied to the  $R_{\text{L}}$  terminal cannot exceed the supply voltage,  $V_{\text{CC}}$  or go below ground, GND.  $R_{\text{L}}$  and  $R_{\text{H}}$  are electrically interchangeable.

### $\overline{\text{CS}}$ : Chip Select

The chip select input is used to activate the control input of the device and is active low. When in a high state, activity on the  $\overline{\text{INC}}$  and  $\text{U}/\overline{\text{D}}$  inputs will not affect or change the position of the wiper.

### $V_{\text{CC}}$ : Supply Input for the device.

## DEVICE OPERATION

The CAT5127 operates like a digitally controlled variable resistor with  $R_H$  and  $R_L$  equivalent to the high and low terminals. There are 32 available tap positions including the resistor end points,  $R_H$  and  $R_L$ . There are 31 resistor elements connected in series between the  $R_H$  and  $R_L$  terminals.

The CAT5129 operates like a digitally controlled variable resistor with  $R_H$  equivalent to the high terminal. There are 32 available tap positions including the resistor end points,  $R_H$  and GND. There are 31 resistor elements connected in series between the  $R_H$  and GND terminals.

Operation is controlled by three inputs,  $\overline{INC}$ ,  $U/\overline{D}$  and  $\overline{CS}$ . These inputs control a five-bit up/down counter whose output is decoded to select the wiper position. The selected wiper position can be stored in nonvolatile memory using the  $\overline{INC}$  and  $\overline{CS}$  inputs.

With  $\overline{CS}$  set LOW, the device is selected and will respond to the  $U/\overline{D}$  and  $\overline{INC}$  inputs. HIGH to LOW transitions on  $\overline{INC}$  will increment or decrement the wiper (depending on the state of the  $U/\overline{D}$  input and five-bit counter). The wiper, when at either end terminal, acts like its mechanical equivalent and does not move beyond the last position. The value of the counter is stored in nonvolatile memory whenever  $\overline{CS}$  transitions HIGH while the  $\overline{INC}$  input is also HIGH. When the device is powered-down, the last stored wiper counter position is maintained in the nonvolatile memory. When power is restored, the contents of the memory are recalled and the counter is set to the value stored.

With  $\overline{INC}$  set low, the device may be de-selected and powered down without storing the current wiper position in nonvolatile memory. This allows the system to always power up to a preset value stored in nonvolatile memory.

## OPERATION MODES

$\overline{INC}$	$\overline{CS}$	$U/\overline{D}$	Operation
High to Low	Low	High	Wiper toward H
High to Low	Low	Low	Wiper toward L/GND
High	Low to High	X	Store Wiper Position
Low	Low to High	X	No Store, Return to Standby
X	High	X	Standby

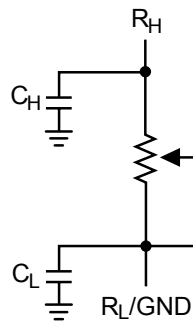

**Variable Resistor Equivalent Circuit**

**ABSOLUTE MAXIMUM RATINGS<sup>(1)</sup>**

Parameters	Ratings	Units
Supply Voltage $V_{CC}$ to GND	-0.5 to +7V	V
Inputs		
$\overline{CS}$ to GND	-0.5 to $V_{CC} + 0.5$	V
$\overline{INC}$ to GND	-0.5 to $V_{CC} + 0.5$	V
$U/\overline{D}$ to GND	-0.5 to $V_{CC} + 0.5$	V
H to GND	-0.5 to $V_{CC} + 0.5$	V
L to GND	-0.5 to $V_{CC} + 0.5$	V
W to GND	-0.5 to $V_{CC} + 0.5$	V

Parameters	Ratings	Units
Operating Ambient Temperature		
Commercial ('C' or Blank suffix)	0 to 70	°C
Industrial ('I' suffix)	-40 to +85	°C
Junction Temperature	+150	°C
Storage Temperature	-65 to 150	°C
Lead Soldering (10 sec max)	+300	°C

**RELIABILITY CHARACTERISTICS**

Symbol	Parameter	Test Method	Min	Typ	Max	Units
$V_{ZAP}^{(2)}$	ESD Susceptibility	MIL-STD-883, Test Method 3015	2000			V
$I_{LTH}^{(2)(3)}$	Latch-Up	JEDEC Standard 17	100			mA
$T_{DR}$	Data Retention	MIL-STD-883, Test Method 1008	100			Years
$N_{END}$	Endurance	MIL-STD-883, Test Method 1003	1,000,000			Stores

**Notes:**

- (1) Stresses above those listed under "Absolute Maximum Ratings" may cause permanent damage to the device. These are stress ratings only, and functional operation of the device at these or any other conditions outside of those listed in the operational sections of this specification is not implied. Exposure to any absolute maximum rating for extended periods may affect device performance and reliability.
- (2) This parameter is tested initially and after a design or process change that affects the parameter.
- (3) Latch-up protection is provided for stresses up to 100mA on address and data pins from -1V to  $V_{CC} + 1V$
- (4) These parameters are periodically sampled and are not 100% tested.

**DC ELECTRICAL CHARACTERISTICS**
 $V_{CC} = +2.5V$  to  $+5.5V$  unless otherwise specified

**Power Supply**

Symbol	Parameter	Conditions	Min	Typ	Max	Units
$V_{CC}$	Operating Voltage Range		2.5		5.5	V
$I_{CC1}$	Supply Current (Increment)	$V_{CC} = 5.5V, f = 1MHz, I_W = 0$		0.4	10	$\mu A$
$I_{CC2}$	Supply Current (Write)	Programming, $V_{CC} = 5.5V$		300	1000	$\mu A$
		$V_{CC} = 3V$		150	500	$\mu A$
$I_{SB1}^{(1)}$	Supply Current (Standby)	$\overline{CS} = V_{CC}$ $U/\overline{D}, \overline{INC} = V_{CC}$ or GND		0.35	1	$\mu A$

**Logic Inputs**

Symbol	Parameter	Conditions	Min	Typ	Max	Units
$I_{IH}$	Input Leakage Current	$V_{IN} = V_{CC}$			10	$\mu A$
$I_{IL}$	Input Leakage Current	$V_{IN} = 0V$			-10	$\mu A$
$V_{IH1}$	TTL High Level Input Voltage	$4.5V \leq V_{CC} \leq 5.5V$	2		$V_{CC}$	V
$V_{IL1}$	TTL Low Level Input Voltage		0		0.8	V
$V_{IH2}$	CMOS High Level Input Voltage	$2.5V \leq V_{CC} \leq 6V$	$V_{CC} \times 0.7$		$V_{CC} + 0.3$	V
$V_{IL2}$	CMOS Low Level Input Voltage		-0.3		$V_{CC} \times 0.2$	V

**POTENTIOMETER CHARACTERISTICS**

Symbol	Parameter	Conditions	Min	Typ	Max	Units
$R_{POT}$	Potentiometer Resistance	-10 Device		10		k $\Omega$
		-50 Device		50		
		-00 Device		100		
$R_{TOL}$	Pot Resistance Tolerance				$\pm 20$	%
$V_{RH}$	Voltage on $R_H$ pin		0		$V_{CC}$	V
$V_{RL}$	Voltage on $R_L$ pin		0		$V_{CC}$	V
RES	Resolution			3.2		%
INL	Integral Linearity Error	$I_W \leq 2\mu A$		0.5	1	LSB
DNL	Differential Linearity Error	$I_W \leq 2\mu A$		0.25	0.5	LSB
$R_{Wi}$	Wiper Resistance	$V_{CC} = 5V, I_W = 1mA$		70	400	$\Omega$
		$V_{CC} = 2.5V, I_W = 1mA$		150	1000	$\Omega$
$I_W^{(2)}$	Wiper Current				1	mA
$TC_{RPOT}^{(3)}$	TC of Pot Resistance			$\pm 30$	$\pm 300$	ppm/ $^{\circ}C$
$TC_{RATIO}^{(3)}$	Ratiometric TC			$\pm 3$	20	ppm/ $^{\circ}C$
$V_N^{(3)}$	Noise	100kHz / 1kHz		8/24		nV/ $\sqrt{Hz}$
$C_H/C_L/C_W^{(3)}$	Potentiometer Capacitances			8/8/25		pF
$F_c^{(3)}$	Frequency Response	Passive Attenuator, 10k $\Omega$		1.7		MHz

**Notes:**

- (1) Latch-up protection is provided for stresses up to 100mA on address and data pins from -1V to  $V_{CC} + 1V$
- (2)  $I_W$  = source or sink
- (3) These parameters are periodically sampled and are not 100% tested.

**AC TEST CONDITIONS**

V <sub>CC</sub> Range	2.5V ≤ V <sub>CC</sub> ≤ 5.5V
Input Pulse Levels	0.2V <sub>CC</sub> to 0.7V <sub>CC</sub>
Input Rise and Fall Times	10ns
Input Reference Levels	0.5V <sub>CC</sub>

**AC OPERATING CHARACTERISTICS**

 V<sub>CC</sub> = +2.5V to +5.5V, V<sub>H</sub> = V<sub>CC</sub>, V<sub>L</sub> = 0V, unless otherwise specified

Symbol	Parameter	Min	Typ(1)	Max	Units
t <sub>CI</sub>	$\overline{CS}$ to $\overline{INC}$ Setup	100			ns
t <sub>DI</sub>	U/ $\overline{D}$ to $\overline{INC}$ Setup	50			ns
t <sub>ID</sub>	U/ $\overline{D}$ to $\overline{INC}$ Hold	100			ns
t <sub>IL</sub>	$\overline{INC}$ LOW Period	250			ns
t <sub>IH</sub>	$\overline{INC}$ HIGH Period	250			ns
t <sub>IC</sub>	$\overline{INC}$ Inactive to CS Inactive	1			μs
t <sub>CPH</sub>	$\overline{CS}$ Deselect Time (NO STORE)	100			ns
t <sub>CPH</sub>	$\overline{CS}$ Deselect Time (STORE)	10			ms
t <sub>IR</sub>	$\overline{INC}$ to R <sub>H</sub> Change		1	5	μs
t <sub>CYC</sub>	$\overline{INC}$ Cycle Time	1			μs
t <sub>R</sub> , t <sub>F</sub> <sup>(2)</sup>	$\overline{INC}$ Input Rise and Fall Time			500	μs
t <sub>PU</sub> <sup>(2)</sup>	Power-up to Wiper Stable			1	ms
t <sub>WR</sub>	Store Cycle		2	5	ms

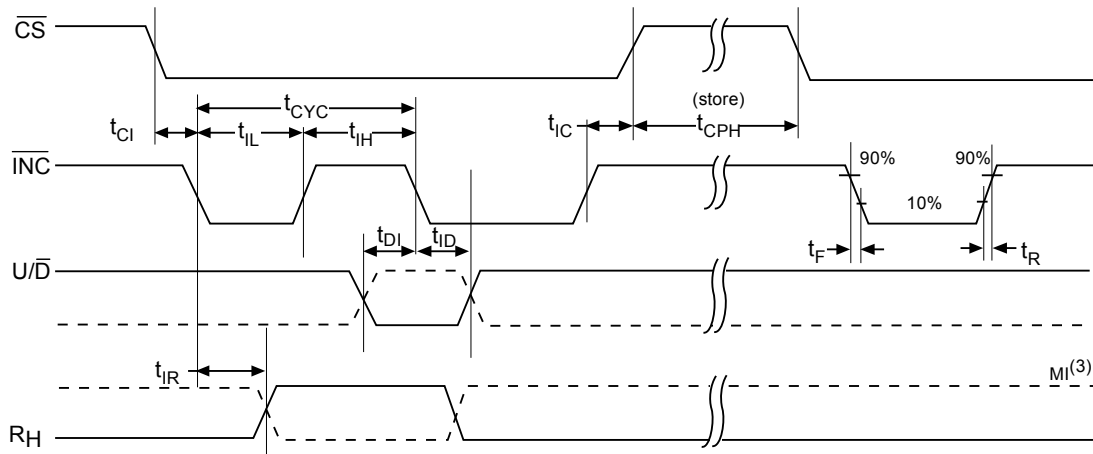
**A.C. TIMING**

**Notes:**

- (1) Typical values are for T<sub>A</sub>=25°C and nominal supply voltage.
- (2) This parameter is periodically sampled and not 100% tested.
- (3) MI in the A.C. Timing diagram refers to the minimum incremental change in the W output due to a change in the wiper position.

## APPLICATION INFORMATION

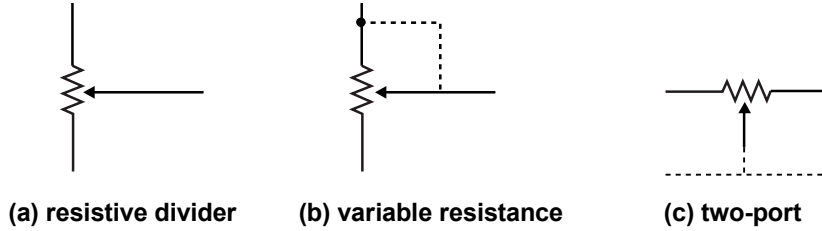
### Potentiometer Configurations



### Applications

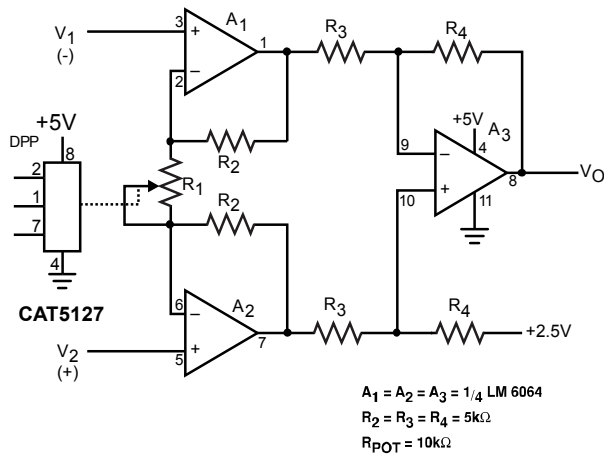

**Programmable Instrumentation Amplifier**

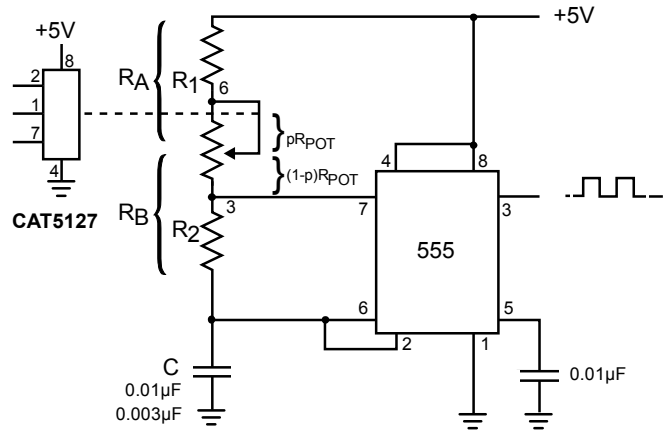

**Programmable Sq. Wave Oscillator (555)**

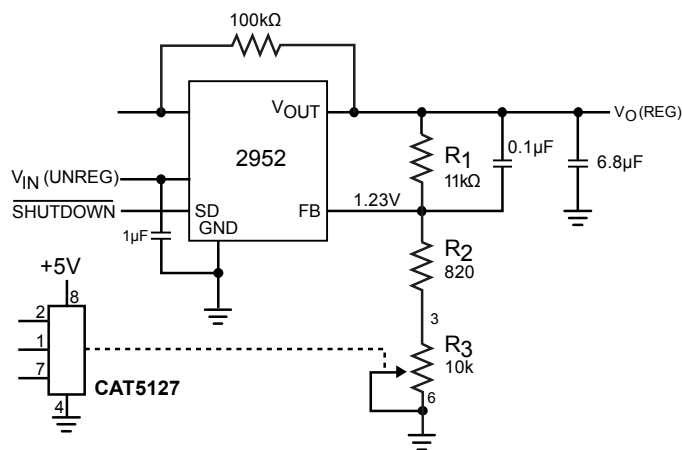

**Programmable Voltage Regulator**

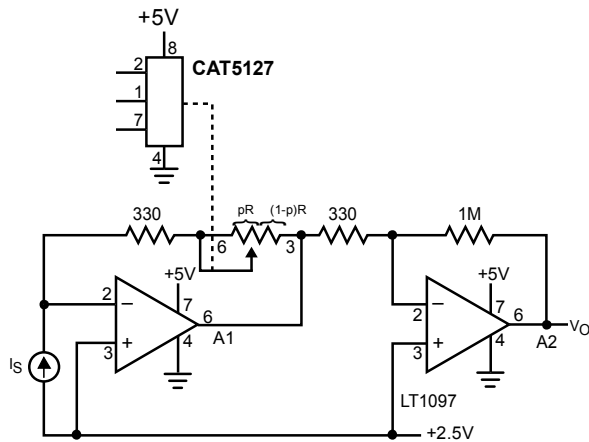

**Programmable I to V converter**

**PACKAGE OUTLINES**

**8-LEAD MSOP**

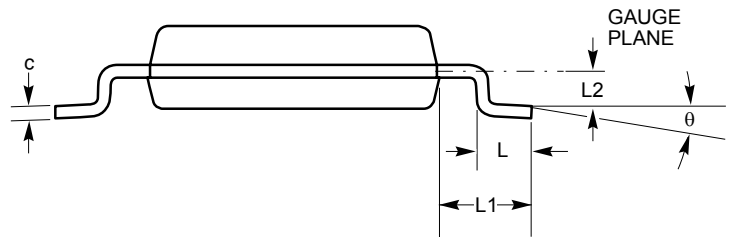
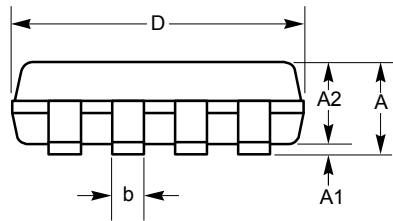
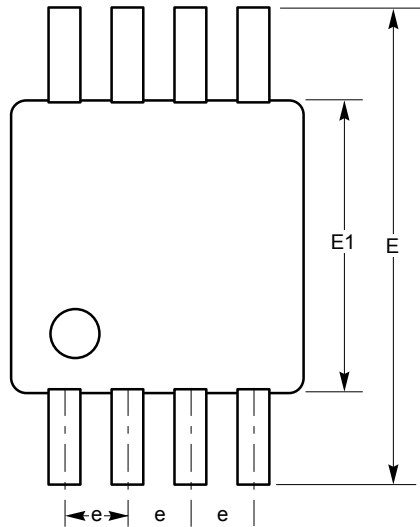

SYMBOL	MIN	NOM	MAX
A			1.1
A1	0.05	0.10	0.15
A2	0.75	0.85	0.95
b	0.28	0.33	0.38
c			
D	2.90	3.00	3.10
E	4.80	4.90	5.00
E1	2.90	3.00	3.10
e	0.65 BSC		
L	0.35	0.45	0.55
L1			
L2			
$\theta$	0°		6°

For current Tape and Reel information,  
download the PDF file from:  
<http://www.catsemi.com/documents/tapeandreel.pdf>.

**Notes:**

- (1) All dimensions are in millimeters. Angles in degrees.
- (2) Complies with JEDEC Specification MS-187.
- (3) Stand off height/coplanarity are considered as special characteristics.



**8-LEAD TDFN (2.5 x 2.0mm)**

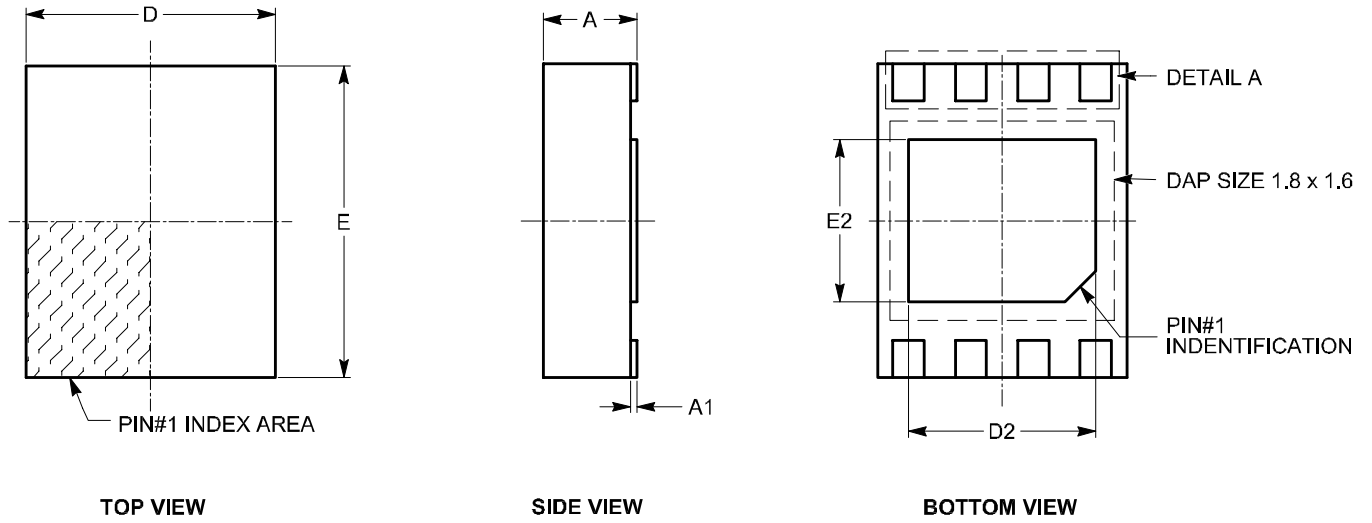

SYMBOL	MIN	NOM	MAX
A	0.70	0.75	0.80
A1	0.00	0.02	0.05
A3	0.20 REF		
b	0.20	0.25	0.30
D	1.90	2.00	2.10
D2	1.40	1.50	1.60
E	2.40	2.50	2.60
E2	1.20	1.30	1.40
e	0.50 TYP		
L	0.20	0.30	0.40

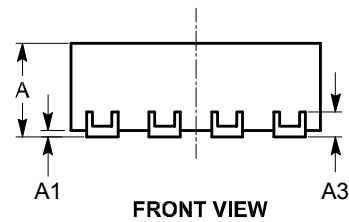
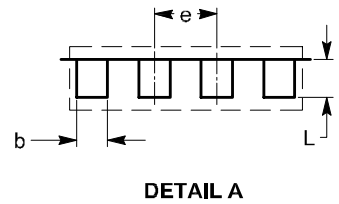

**Notes:**

- (1) All dimensions are in millimeters. Angles in degrees.
- (2) Complies with JEDEC specification MO-229.

**For current Tape and Reel information,  
download the PDF file from:  
<http://www.catsemi.com/documents/tapeandreeel.pdf>.**

**CAT5127, CAT5129**

**6-LEAD TSOT-23**

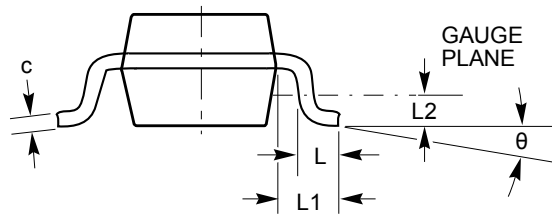
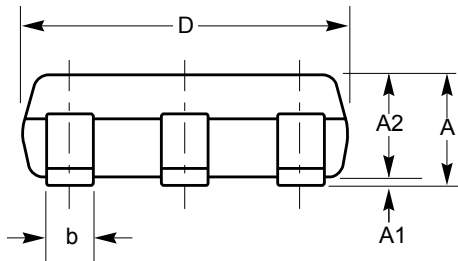
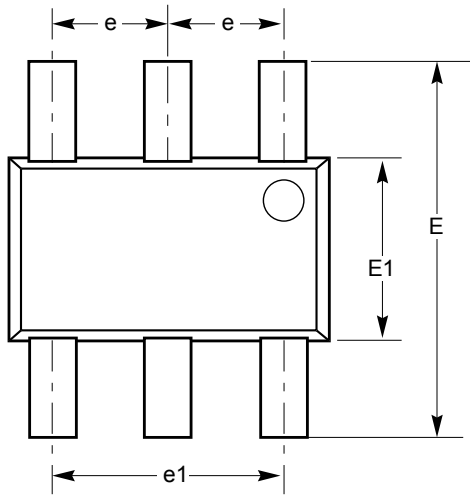

SYMBOL	MIN	NOM	MAX
A	—	—	1.00
A1	0.01	0.05	0.1
A2	0.80	0.87	0.90
b	0.30	—	0.45
c	0.12	0.15	0.20
D	2.90 BSC		
E	2.70	2.80	2.90
E1	1.60 BSC		
e	0.95 BSC		
e1	1.90 BSC		
L	0.30	0.40	0.50
L1	0.60 REF		
L2	0.25 BSC		
$\theta$	0°		8°

**For current Tape and Reel information,  
download the PDF file from:  
<http://www.catsemi.com/documents/tapeandreel.pdf>.**

**Notes:**

- (1) All dimensions are in millimeters. Angles in degrees.
- (2) Complies with JEDEC specification MO-193.

**EXAMPLE OF ORDERING INFORMATION**

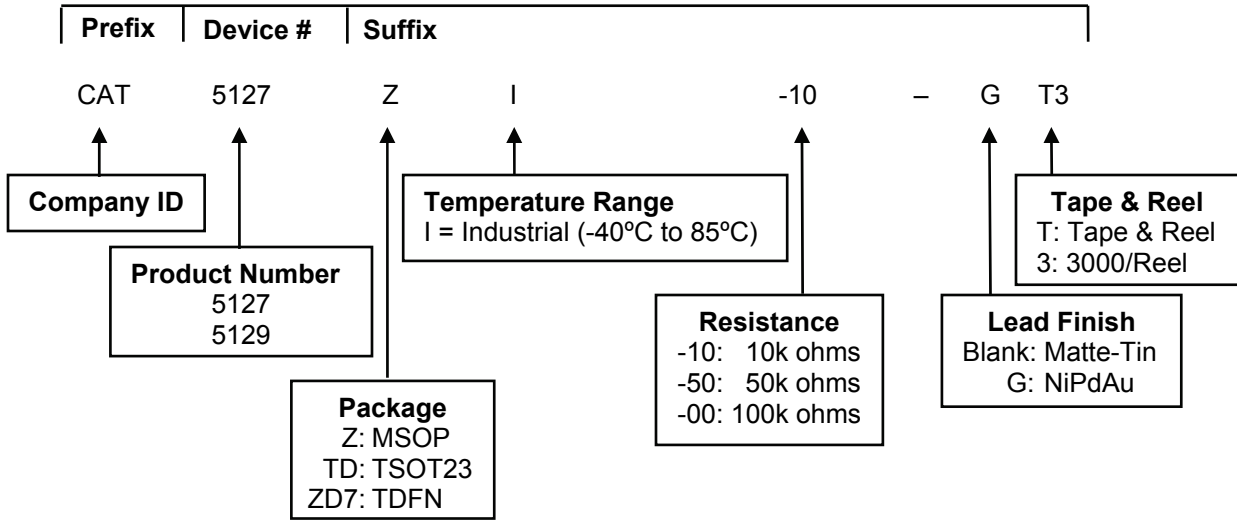

**Notes:**

- (1) All packages are RoHS-compliant (Lead-free, Halogen-free).
- (2) The standard lead finish is Matte-Tin.
- (3) The device used in the above example is a CAT5127ZI-10-GT3 (MSOP, Industrial Temperature range, 10kΩ, NiPdAu, Tape & Reel).
- (4) For additional package and temperature options, please contact your nearest Catalyst Semiconductor Sales office.

**ORDERING INFORMATION**

Device	Ordering Part Number	Resistor [kΩ]	Top Marking	Pin/Package	Part Per Reel
<b>CAT5127</b>	CAT5127ZI-10-T3	10	ABPU	MSOP-8	3000
	CAT5127ZI-50-T3 <sup>(5)</sup>	50	ABPV	MSOP-8	3000
	CAT5127ZI-00-T3 <sup>(5)</sup>	100	ABPY	MSOP-8	3000
	CAT5127ZI-10-GT3	10	ABNA	MSOP-8	3000
	CAT5127ZI-50-GT3 <sup>(5)</sup>	50	ABNB	MSOP-8	3000
	CAT5127ZI-00-GT3 <sup>(5)</sup>	100	ABNK	MSOP-8	3000
	CAT5127ZD7I-10-GT3	10	HB	TDFN-8	3000
	CAT5127ZD7I-50-GT3 <sup>(5)</sup>	50	HC	TDFN-8	3000
	CAT5127ZD7I-00-GT3 <sup>(5)</sup>	100	HD	TDFN-8	3000
<b>CAT5129</b>	CAT5129TDI-10-T3	10	PDym <sup>(6)</sup>	TSOT23-6	3000
	CAT5129TDI-50-T3 <sup>(5)</sup>	50	PEym <sup>(6)</sup>	TSOT23-6	3000
	CAT5129TDI-00-T3 <sup>(5)</sup>	100	PFym <sup>(6)</sup>	TSOT23-6	3000
	CAT5129TDI-10-GT3	10	PAym <sup>(6)</sup>	TSOT23-6	3000
	CAT5129TDI-50-GT3 <sup>(5)</sup>	50	PBym <sup>(6)</sup>	TSOT23-6	3000
	CAT5129TDI-00-GT3 <sup>(5)</sup>	100	PCym <sup>(6)</sup>	TSOT23-6	3000

**Notes:**

- (5) Contact factory for availability.
- (6) y = Production year (digit), m = Production month (digit).

## REVISION HISTORY

Date	Rev.	Reason
12/18/06	A	Initial Issue

---

### Copyrights, Trademarks and Patents

Trademarks and registered trademarks of Catalyst Semiconductor include each of the following:

Beyond Memory™, DPP™, EZDim™, MiniPot™, and Quad-Mode™

Catalyst Semiconductor has been issued U.S. and foreign patents and has patent applications pending that protect its products.

*CATALYST SEMICONDUCTOR MAKES NO WARRANTY, REPRESENTATION OR GUARANTEE, EXPRESS OR IMPLIED, REGARDING THE SUITABILITY OF ITS PRODUCTS FOR ANY PARTICULAR PURPOSE, NOR THAT THE USE OF ITS PRODUCTS WILL NOT INFRINGE ITS INTELLECTUAL PROPERTY RIGHTS OR THE RIGHTS OF THIRD PARTIES WITH RESPECT TO ANY PARTICULAR USE OR APPLICATION AND SPECIFICALLY DISCLAIMS ANY AND ALL LIABILITY ARISING OUT OF ANY SUCH USE OR APPLICATION, INCLUDING BUT NOT LIMITED TO, CONSEQUENTIAL OR INCIDENTAL DAMAGES.*

Catalyst Semiconductor products are not designed, intended, or authorized for use as components in systems intended for surgical implant into the body, or other applications intended to support or sustain life, or for any other application in which the failure of the Catalyst Semiconductor product could create a situation where personal injury or death may occur.

Catalyst Semiconductor reserves the right to make changes to or discontinue any product or service described herein without notice. Products with data sheets labeled "Advance Information" or "Preliminary" and other products described herein may not be in production or offered for sale.

Catalyst Semiconductor advises customers to obtain the current version of the relevant product information before placing orders. Circuit diagrams illustrate typical semiconductor applications and may not be complete.

---



Catalyst Semiconductor, Inc.  
Corporate Headquarters  
2975 Stender Way  
Santa Clara, CA 95054  
Phone: 408.542.1000  
Fax: 408.542.1200  
www.catsemi.com

Document No: 2127  
Revision: A  
Issue date: 12/18/06