

CDCV850, CDCV850I

2.5-V PHASE LOCK LOOP CLOCK DRIVER WITH 2-LINE SERIAL INTERFACE

SCAS647B – OCTOBER 2000 – REVISED DECEMBER 2002

- **Phase-Lock Loop Clock Driver for Double Data-Rate Synchronous DRAM Applications**
- **Spread Spectrum Clock Compatible**
- **Operating Frequency: 60 to 140 MHz**
- **Low Jitter (cyc–cyc): ± 75 ps**
- **Distributes One Differential Clock Input to Ten Differential Outputs**
- **Two-Line Serial Interface Provides Output Enable and Functional Control**
- **Outputs Are Put Into a High-Impedance State When the Input Differential Clocks Are < 20 MHz**
- **48-Pin TSSOP Package**
- **Consumes < 250 - μ A Quiescent Current**
- **External Feedback Pins (FBIN, $\overline{\text{FBIN}}$) Are Used to Synchronize the Outputs to the Input Clocks**

description

The CDCV850 is a high-performance, low-skew, low-jitter zero delay buffer that distributes a differential clock input pair (CLK, $\overline{\text{CLK}}$) to ten differential pairs of clock outputs (Y[0:9], $\overline{\text{Y}}[0:9]$) and one differential pair of feedback clock outputs (FBOUT, $\overline{\text{FBOUT}}$). The clock outputs are controlled by the clock inputs (CLK, $\overline{\text{CLK}}$), the feedback clocks (FBIN, $\overline{\text{FBIN}}$), the 2-line serial interface (SDATA, SCLK), and the analog power input (AV_{DD}). A two-line serial interface can put the individual output clock pairs in a high-impedance state. When the AV_{DD} terminal is tied to GND, the PLL is turned off and bypassed for test purposes.

The device provides a standard mode (100 Kbits/s) 2-line serial interface for device control. The implementation is as a slave/receiver. The device address is specified in the 2-line serial device address table. Both of the 2-line serial inputs (SDATA and SCLK) provide integrated pullup resistors (typically 100 k Ω).

Two 8-bit, 2-line serial registers provide individual enable control for each output pair. All outputs default to enabled at powerup. Each output pair can be placed in a high-impedance mode, when a low-level control bit is written to the control register. The registers must be accessed in sequential order (i.e., random access of the registers not supported). The serial interface circuit can be supplied with either 2.5 V or 3.3 V (at VDDI) in applications where this programming option is not required (after power up, all output pairs will then be enabled).

When the input frequency falls below a suggested detection frequency that is below 20 MHz (typically 10 MHz), the output pairs are put into a high-impedance condition, the PLL is shut down, and the device will enter a low power mode. The CDCV850 is also able to track spread spectrum clocking for reduced EMI.

Since the CDCV850 is based on PLL circuitry, it requires a stabilization time to achieve phase-lock of the PLL. This stabilization time is required following power up, as well as changes to various 2-line serial registers that affect the PLL. The CDCV850 is characterized for both commercial and industrial temperature ranges.

DGG PACKAGE
(TOP VIEW)

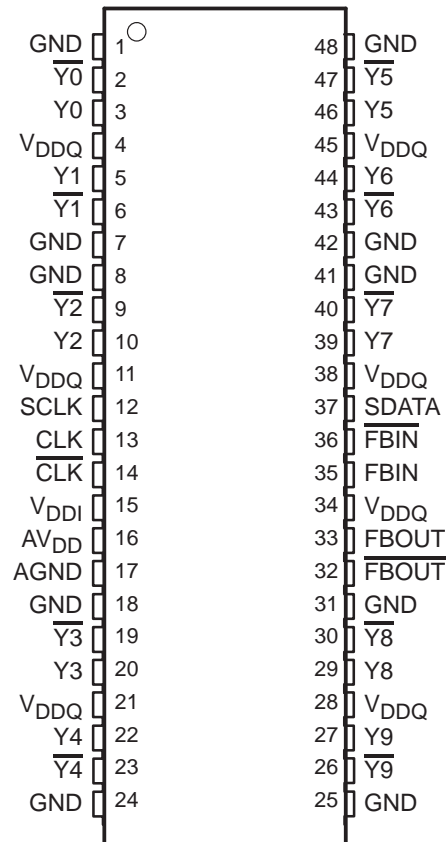

Please be aware that an important notice concerning availability, standard warranty, and use in critical applications of Texas Instruments semiconductor products and disclaimers thereto appears at the end of this data sheet.

PRODUCTION DATA information is current as of publication date. Products conform to specifications per the terms of Texas Instruments standard warranty. Production processing does not necessarily include testing of all parameters.



POST OFFICE BOX 655303 • DALLAS, TEXAS 75265

Copyright © 2002, Texas Instruments Incorporated

CDCV850, CDCV850I

2.5-V PHASE LOCK LOOP CLOCK DRIVER

WITH 2-LINE SERIAL INTERFACE

SCAS647B – OCTOBER 2000 – REVISED DECEMBER 2002

AVAILABLE OPTIONS

T _A	PACKAGED DEVICES
	TSSOP (DGG)
0°C to 85°C	CDCV850DGG
-40°C to 85°C	CDCV850IDGG

FUNCTION TABLE (Select Functions)

INPUTS			OUTPUTS†				PLL
AV _{DD}	CLK	CLK	Y[0:9]	Y[0:9]	F _{BOUT}	F _{BOUT}	
GND	L	H	L	H	L	H	Bypassed/Off
GND	H	L	H	L	H	L	Bypassed/Off
2.5 V (nom)	L	H	L	H	L	H	On
2.5 V (nom)	H	L	H	L	H	L	On
2.5 V (nom)	<20 MHz	<20 MHz	Hi-Z	Hi-Z	Hi-Z	Hi-Z	Off

† Each output pair (except F_{BOUT}, F_{BOUT}) can be put into a high-impedance state through the 2-line serial interface.

functional block diagram

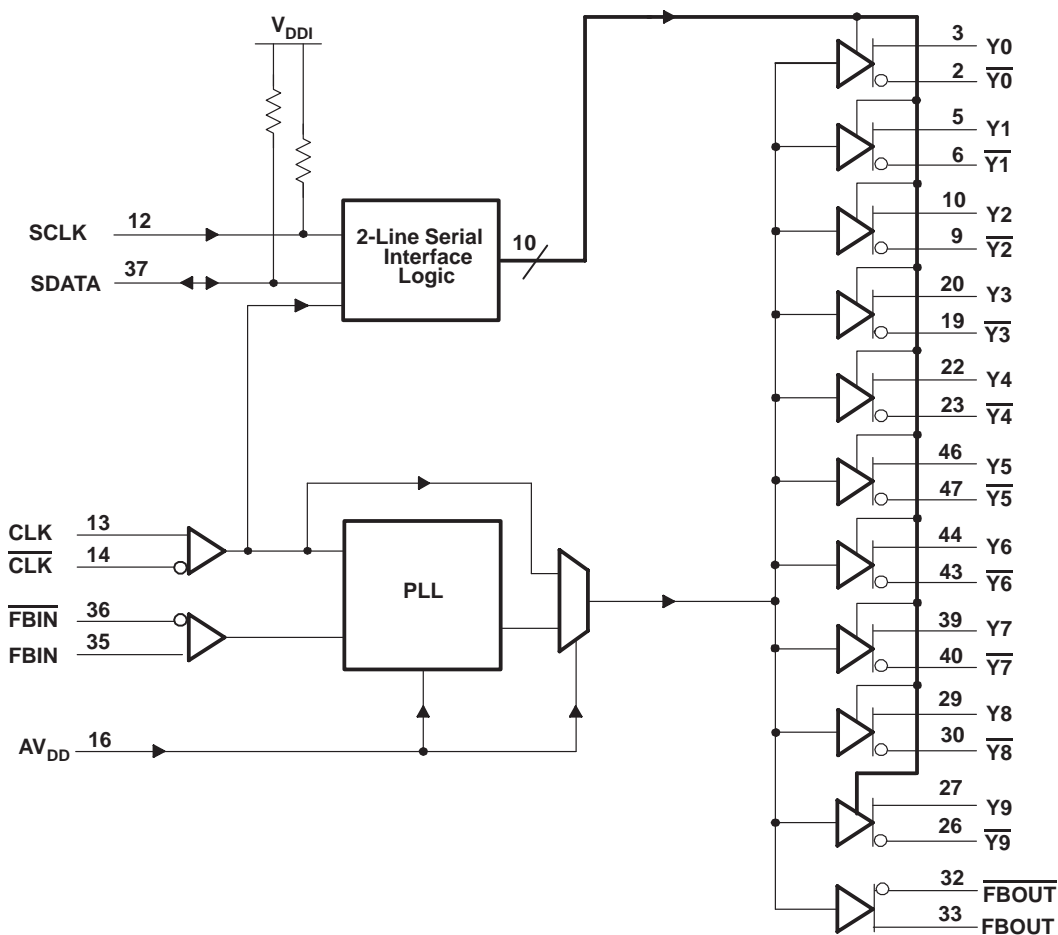

CDCV850, CDCV850I
2.5-V PHASE LOCK LOOP CLOCK DRIVER
WITH 2-LINE SERIAL INTERFACE

SCAS647B – OCTOBER 2000 – REVISED DECEMBER 2002

Terminal Functions

TERMINAL NAME	NO.	I/O	DESCRIPTION
AGND	17		Ground for 2.5-V analog supply
AV _{DD}	16		2.5-V analog supply
CLK, $\overline{\text{CLK}}$	13, 14	I	Differential clock input
$\overline{\text{FBIN}}$, FBIN	35, 36	I	Feedback differential clock input
$\overline{\text{FBOU}}$, FBOU	32, 33	O	Feedback differential clock output
GND	1, 7, 8, 18, 24, 25, 31, 41, 42, 48		Ground
SCLK	12	I	Clock input for 2-line serial interface
SDATA	37	I/O	Data input/output for 2-line serial interface
V _{DDQ}	4, 11, 21, 28, 34, 38, 45		2.5-V supply
V _{DDI}	15	I	2.5-V or 3.3-V supply for 2-line serial interface
Y[0:9]	3, 5, 10, 20, 22, 27, 29, 39, 44, 46	O	Buffered output copies of input clock, CLK
$\overline{\text{Y}}[0:9]$	2, 6, 9, 19, 23, 26, 30, 40, 43, 47	O	Buffered output copies of input clock, $\overline{\text{CLK}}$

CDCV850, CDCV850I

2.5-V PHASE LOCK LOOP CLOCK DRIVER

WITH 2-LINE SERIAL INTERFACE

SCAS647B – OCTOBER 2000 – REVISED DECEMBER 2002

absolute maximum ratings over operating free-air temperature (unless otherwise noted)†

Supply voltage range: V_{DDQ}, AV_{DD}	-0.5 V to 3.6 V
V_{DDI}	-0.5 V to 4.6 V
Input voltage range: V_I (except SCLK and SDATA) (see Notes 1 and 2)	-0.5 V to $V_{DDQ} + 0.5$ V
V_I (SCLK, SDATA) (see Notes 1 and 2)	-0.5 V to $V_{DDI} + 0.5$ V
Output voltage range: V_O (except SDATA) (see Notes 1 and 2)	-0.5 V to $V_{DDQ} + 0.5$ V
V_O (SDATA) (see Notes 1 and 2)	-0.5 V to $V_{DDQ} + 0.5$ V
Input clamp current, I_{IK} ($V_I < 0$ or $V_I > V_{DDQ}$)	± 50 mA
Output clamp current, I_{OK} ($V_O < 0$ or $V_O > V_{DDQ}$)	± 50 mA
Continuous output current, I_O ($V_O = 0$ to V_{DDQ})	± 50 mA
Package thermal impedance, θ_{JA} (see Note 3): DGG package	89°C/W
Storage temperature range T_{stg}	-65°C to 150°C

† Stresses beyond those listed under “absolute maximum ratings” may cause permanent damage to the device. These are stress ratings only, and functional operation of the device at these or any other conditions beyond those indicated under “recommended operating conditions” is not implied. Exposure to absolute-maximum-rated conditions for extended periods may affect device reliability.

- NOTES: 1. The input and output negative voltage ratings may be exceeded if the input and output clamp-current ratings are observed.
 2. This value is limited to 3.6 V maximum.
 3. The package thermal impedance is calculated in accordance with JESD 51.

recommended operating conditions (see Note 4)

		MIN	TYP	MAX	UNIT
Supply voltage	V_{DDQ}, AV_{DD}	2.3		2.7	V
	V_{DDI} (see Note 5)	2.3		3.6	
Low level input voltage, V_{IL}	CLK, \overline{CLK} , HCSL Buffer only		0	0.24	V
	CLK, \overline{CLK}	-0.3		$V_{DDQ} - 0.4$	
	FBIN, \overline{FBIN}			$V_{DDQ}/2 - 0.18$	
	SDATA, SCLK			$0.3 \times V_{DDI}$	
High level input voltage, V_{IH}	CLK, \overline{CLK} , HCSL Buffer only	0.66	0.71		V
	CLK, \overline{CLK}	0.4		$V_{DDQ} + 0.3$	
	FBIN, \overline{FBIN}	$V_{DDQ}/2 + 0.18$			
	SDATA, SCLK	$0.7 \times V_{DDI}$			
DC input signal voltage (see Note 6)		-0.3		$V_{DDQ} + 0.3$	V
Differential input signal voltage, V_{ID} (see Note 7)	DC CLK, FBIN	0.36		$V_{DDQ} + 0.6$	V
	AC CLK, FBIN	0.2		$V_{DDQ} + 0.6$	
Input differential pair cross-voltage, V_{IX} (see Note 8)		$0.45 \times (V_{IH} - V_{IL})$		$0.55 \times (V_{IH} - V_{IL})$	V
High-level output current, I_{OH}				-12	mA
Low-level output current, I_{OL}				12	V
		SDATA		3	mA
Input slew rate, SR (see Figure 8)		1		4	V/ns
SSC modulation frequency		30		33.3	kHz
SSC clock input frequency deviation		0		-0.50	kHz
Operating free-air temperature, T_A	Commercial	0		85	°C
	Industrial	-40		85	

- NOTES: 4. Unused inputs must be held high or low to prevent them from floating.
 5. All devices on the serial interface bus, with input levels related to V_{DDI} , must have one common supply line to which the pullup resistor is connected to.
 6. DC input signal voltage specifies the allowable dc execution of differential input.
 7. Differential input signal voltage specifies the differential voltage $|V_{TR} - V_{CP}|$ required for switching, where V_{TR} is the true input level and V_{CP} is the complementary input level.
 8. Differential cross-point voltage is expected to track variations of V_{CC} and is the voltage at which the differential signals must be crossing.



CDCV850, CDCV850I
2.5-V PHASE LOCK LOOP CLOCK DRIVER
WITH 2-LINE SERIAL INTERFACE

SCAS647B – OCTOBER 2000 – REVISED DECEMBER 2002

electrical characteristics over recommended operating free-air temperature range (unless otherwise noted)

PARAMETER		TEST CONDITIONS	MIN	TYP†	MAX	UNIT
V _{IK}	Input voltage	All inputs V _{DDQ} = 2.3 V, I _I = -18 mA			-1.2	V
V _{OH}	High-level output voltage	V _{DDQ} = min to max, I _{OH} = -1 mA	V _{DDQ} - 0.1			V
		V _{DDQ} = 2.3 V, I _{OH} = -12 mA	1.7			
V _{OL}	Low-level output voltage	V _{DDQ} = min to max, I _{OL} = 1 mA			0.1	V
		V _{DDQ} = 2.3 V, I _{OL} = 12 mA			0.6	
		SDATA V _{DDI} = 3.0 V, I _{OL} = 3 mA			0.4	
I _{OH}	High-level output current	V _{DDQ} = 2.3 V, V _O = 1 V	-18	-32		mA
I _{OL}	Low-level output current	V _{DDQ} = 2.3 V, V _O = 1.2 V	26	35		mA
V _O	Output voltage swing	For load condition see Figure 3	1.1		V _{DDQ} - 0.4	V
V _{OX}	Output differential cross voltage		V _{DDQ} /2 - 0.2	V _{DDQ} /2	V _{DDQ} /2 + 0.2	V
I _I	Input current	SDATA, SCLK V _{DDQ} = 3.6 V, V _I = 0 V to 3.6 V			+10/-50	μA
		CLK, FBIN V _{DDQ} = 2.7 V, V _I = 0 V to 2.7 V			±10	μA
I _{OZ}	High-impedance-state output current	V _{DDQ} = 2.7 V, V _O = V _{DDQ} or GND			±10	μA
I _{DDPD}	Power-down current on V _{DDQ} + AV _{DD}	CLK at 0 MHz; Σ of I _{DD} and A _I DD		150	250	μA
	Power down current on V _{DDI}	CLK at 0 MHz; V _{DDQ} = 3.6 V		3	20	μA
I _{DD}	Dynamic current on V _{DDQ}	V _{DDQ} = 2.7 V, f _O = 100 MHz All differential output pairs are terminated with 120 Ω / C _L = 4 pF		205	230	mA
A _I (DD)	Supply current on AV _{DD}	AV _{DD} = 2.7 V, f _O = 100 MHz		4	6	mA
I _{DDI}	Supply current on V _{DDI}	V _{DDI} = 3.6 V SCLK and SDATA = 3.6 V		1	2	mA
C _I	Input capacitance	V _{DDQ} = 2.5 V, V _I = V _{DDQ} or GND	2	2.5	3	pF
C _O	Output capacitance	V _{DDQ} = 2.5 V, V _O = V _{DDQ} or GND	2.5	3	3.5	pF

† All typical values are at respective nominal V_{DDQ}.

‡ The value of V_{OC} is expected to be |V_{TR} + V_{CPI}|/2. In case of each clock directly terminated by a 120-Ω resistor, where V_{TR} is the true input signal voltage and V_{CPI} is the complementary input signal voltage (see Figure 3).

CDCV850, CDCV850I

2.5-V PHASE LOCK LOOP CLOCK DRIVER

WITH 2-LINE SERIAL INTERFACE

SCAS647B – OCTOBER 2000 – REVISED DECEMBER 2002

timing requirements over recommended ranges of supply voltage and operating free-air temperature

	MIN	MAX	UNIT
f(CLK) Clock frequency	60	140	MHz
Input clock duty cycle	40%	60%	
Stabilization time [†]		10	μs

[†] Time required for the integrated PLL circuit to obtain phase lock of its feedback signal to its reference signal. For phase lock to be obtained, a fixed-frequency, fixed-phase reference signal must be present at CLK. Until phase lock is obtained, the specifications for propagation delay, skew, and jitter parameters given in the switching characteristics table are not applicable. This parameter does not apply for input modulation under SSC application.

timing requirements for the 2-line serial interface over recommended ranges of operating free-air temperature and VDDI from 3.3 V to 3.6 V (see Figure 10)

	MIN	MAX	UNIT
f(SCLK) SCLK frequency		100	kHz
t(BUS) Bus free time	4.7		μs
t _{su} (START) START setup time [†]	4.7		μs
t _h (START) START hold time [†]	4.0		μs
t _w (SCLL) SCLK low pulse duration	4.7		μs
t _w (SCLH) SCLK high pulse duration	4.0		μs
t _r (SDATA) SDATA input rise time		1000	ns
t _f (SDATA) SDATA input fall time		300	ns
t _{su} (SDATA) SDATA setup time	250		ns
t _h (SDATA) SDATA hold time	0		ns
t _{su} (STOP) STOP setup time	4		μs

[†] This conforms to I2C specification, version 2.1.



CDCV850, CDCV850I
2.5-V PHASE LOCK LOOP CLOCK DRIVER
WITH 2-LINE SERIAL INTERFACE

SCAS647B – OCTOBER 2000 – REVISED DECEMBER 2002

switching characteristics over recommended ranges of operating free-air temperature (unless otherwise noted)

PARAMETER		TEST CONDITIONS	MIN	TYP	MAX	UNIT	
t _{pd}	Propagation delay time	Test mode/CLK to any output		4		ns	
t _{PHL}	High-to low-level propagation delay time	SCLK to SDATA (acknowledge)		500 [†]		ns	
t _{en}	Output enable time	Test mode/SDATA to Y-output		85		ns	
t _{dis}	Output disable time	Test mode/SDATA to Y-output		35		ns	
t _{jit(per)}	Jitter (period), See Figure 6	100/133 MHz	-30		30	ps	
t _{jit(cc)}	Jitter (cycle-to-cycle), See Figure 3	100/133 MHz	-30		30	ps	
t _{jit(hper)}	Half-period jitter, See Figure 7	100/133 MHz	-75		75	ps	
t _(∅)	Static phase offset, See Figure 4a	0°C to 85°C	100 MHz/VID on CLK = 0.71 V [‡]		-120	120	ps
			100 MHz/VID on CLK = 0.59 V [§]		-50	160	
			100 MHz/VID on CLK = 0.82 V [¶]		-170	70	
			133 MHz/VID on CLK = 0.71 V [¶]		-50	180	
		-40°C to 85°C	100 MHz/VID on CLK = 0.71 V [‡]		-160	80	ps
			100 MHz/VID on CLK = 0.59 V [§]		-90	120	
			100 MHz/VID on CLK = 0.82 V [¶]		-210	30	
			133 MHz/VID on CLK = 0.71 V [¶]		-80	150	
td _(∅) [#]	Dynamic phase offset, SSC on, See Figure 4b and Figure 9	100 MHz/VID on CLK = 0.71 V [‡]		-190	190	ps	
		133 MHz/VID on CLK = 0.71 V [‡]		-140	140	ps	
	Dynamic phase offset, SSC off, See Figure 4b	100 MHz/VID on CLK = 0.71 V [‡]		-160	160	ps	
		133 MHz/VID on CLK = 0.71 V [‡]		-130	130	ps	
t _{slr(o)}	Output clock slew rate, terminated with 120 Ω/14 pF, See Figures 1 and 8		1		2	V/ns	
t _{slr(o)}	Output clock slew rate, terminated with 120 Ω/4 pF, See Figures 1 and 8		1		3	V/ns	
t _{sk(o)}	Output skew, See Figure 5				75	ps	
	SSC modulation frequency		30		33.3	kHz	
	SSC clock input frequency deviation		0.00		-0.50	%	

[†] This time is for a PLL frequency of 100 MHz.

[‡] According CK00 spec: 6 x I_{ref} at 50 Ω and R_{ref} = 475 Ω

[§] According CK00 spec: 5 x I_{ref} at 50 Ω and R_{ref} = 475 Ω

[¶] According CK00 spec: 7 x I_{ref} at 50 Ω and R_{ref} = 475 Ω

[#] The parameter is assured by design but cannot be 100% production tested.

^{||} All differential output pins are terminated with 120 Ω/4 pF

CDCV850, CDCV850I

2.5-V PHASE LOCK LOOP CLOCK DRIVER

WITH 2-LINE SERIAL INTERFACE

SCAS647B – OCTOBER 2000 – REVISED DECEMBER 2002

2-line serial interface

2-line serial interface slave address

A7	A6	A5	A4	A3	A2	A1	R/W
1	1	0	1	0	0	1	0

Writing to the device is accomplished by sequentially sending the device address D2_H, the dummy bytes (command code and the number of bytes), and the data bytes. This sequence is illustrated in the following tables:

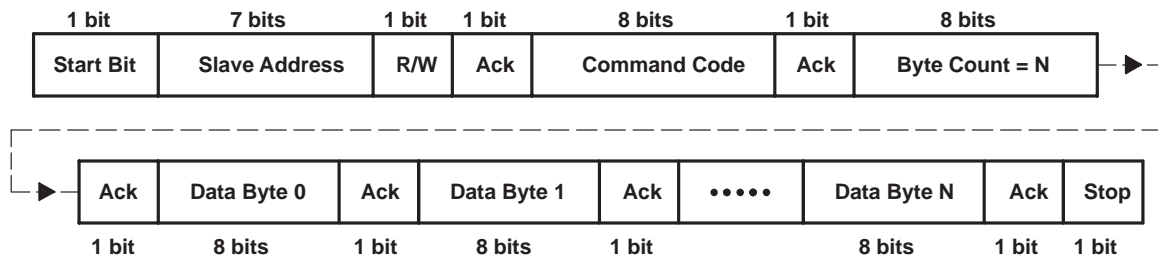

2-line serial interface configuration command bitmap

The 2-line serial command bytes are used to control the output clock pairs (Y[0:9], \overline{Y} [0:9]). The output clock pairs are enabled after power up. During normal operation, the clock pairs can be disabled (set Hi-Z) or enabled (running) by writing the corresponding bit to the data bytes in the following tables:

Byte 0: Enable/Disable Register (H = Enable, L = Disable)

Byte 1: Enable/Disable Register (H = Enable, L = Disable)

BIT	PINS	INITIAL VALUE	DESCRIPTION	BIT	PINS	INITIAL VALUE	DESCRIPTION
7	3, 2	H	Y0, \overline{Y} 0	7	29, 30	H	Y8, \overline{Y} 8
6	5, 6	H	Y1, \overline{Y} 1	6	27, 26	H	Y9, \overline{Y} 9
5	10, 9	H	Y2, \overline{Y} 2	5	–	L	Reserved
4	20, 19	H	Y3, \overline{Y} 3	4	–	L	Reserved
3	22, 23	H	Y4, \overline{Y} 4	3	–	L	Reserved
2	46, 47	H	Y5, \overline{Y} 5	2	–	L	Reserved
1	44, 43	H	Y6, \overline{Y} 6	1	–	L	Reserved
0	39, 40	H	Y7, \overline{Y} 7	0	–	L	Reserved

PARAMETER MEASUREMENT INFORMATION

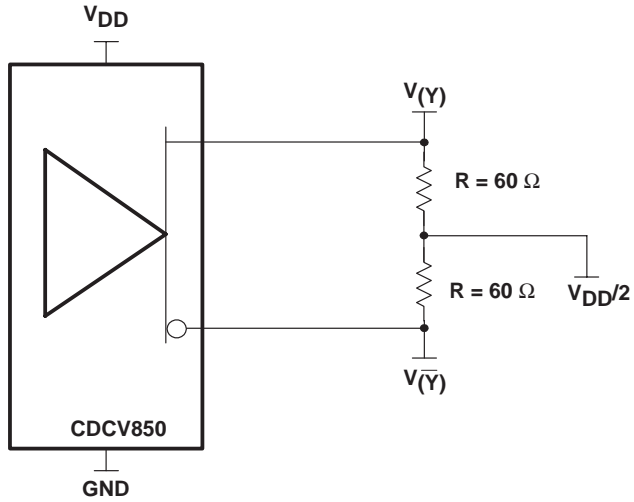

Figure 1. IBIS Model Output Load (used for slew rate measurement)

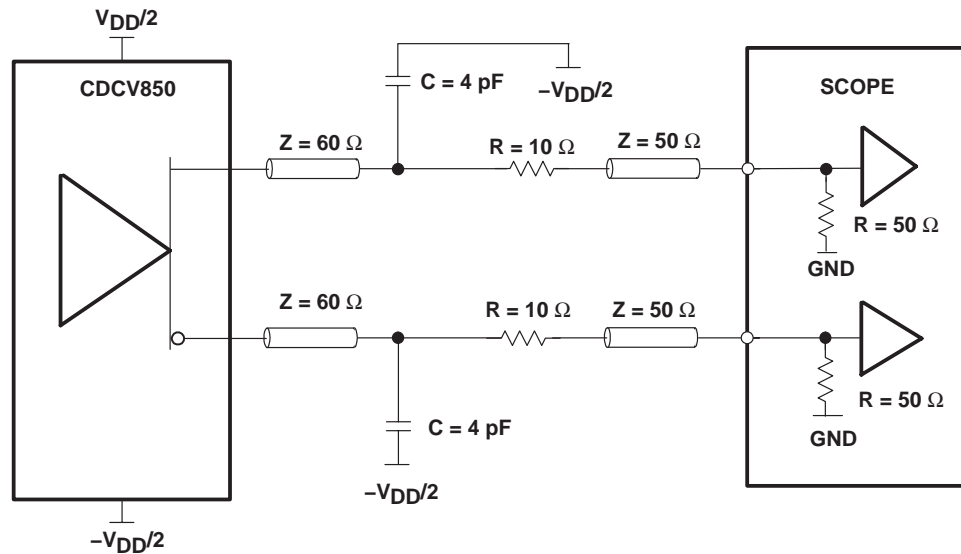

Figure 2. Output Load Test Circuit

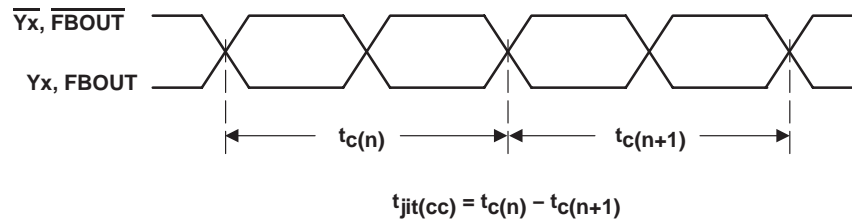
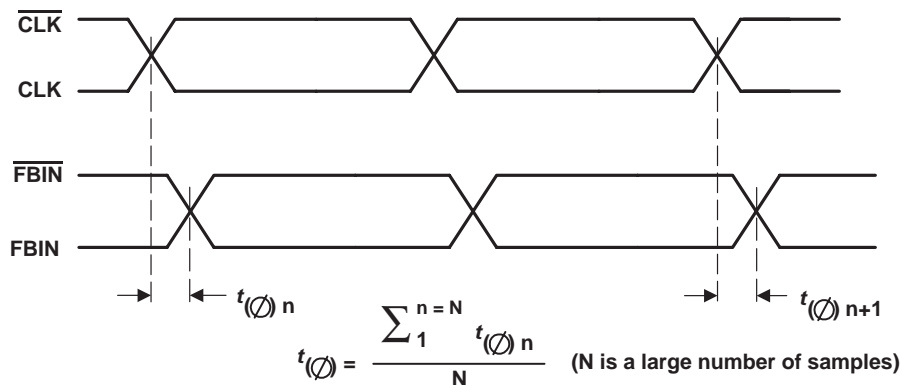

Figure 3. Cycle-to-Cycle Jitter

CDCV850, CDCV850I
2.5-V PHASE LOCK LOOP CLOCK DRIVER
WITH 2-LINE SERIAL INTERFACE

SCAS647B – OCTOBER 2000 – REVISED DECEMBER 2002

PARAMETER MEASUREMENT INFORMATION



(a) Static Phase Offset

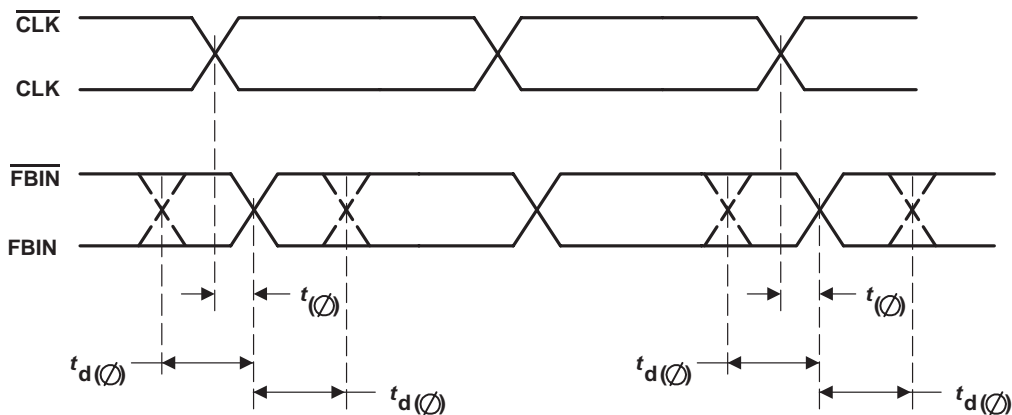

(b) Dynamic Phase Offset

Figure 4. Static Phase Offset

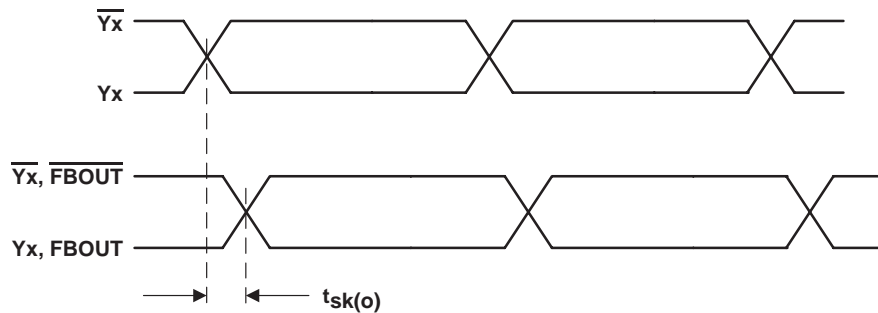

Figure 5. Output Skew

PARAMETER MEASUREMENT INFORMATION

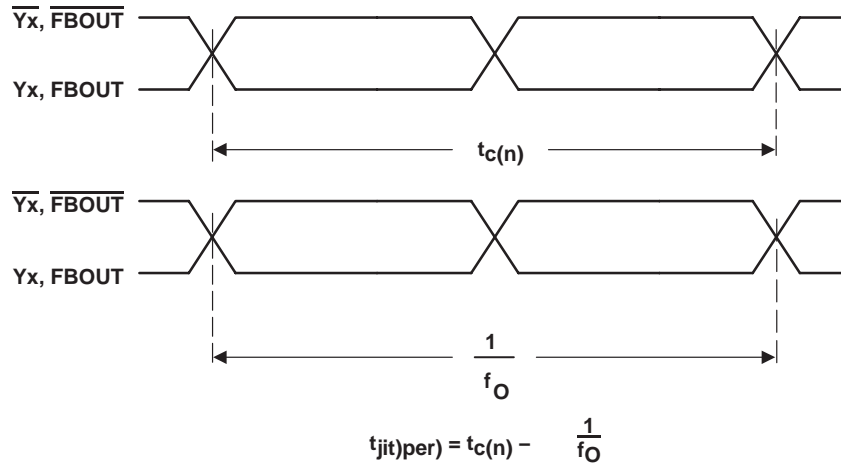

Figure 6. Period Jitter

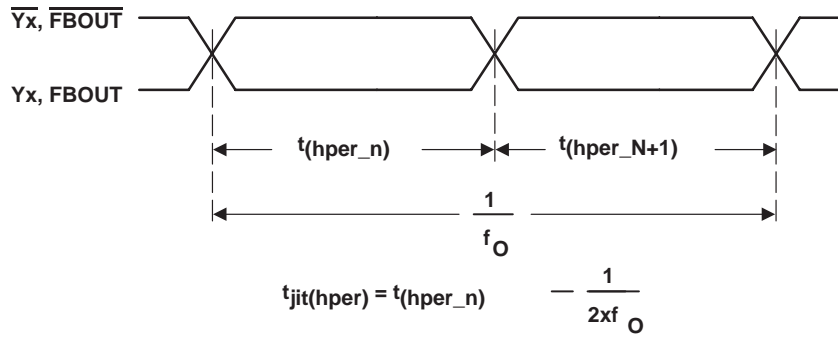

Figure 7. Half-Period Jitter

CDCV850, CDCV850I
2.5-V PHASE LOCK LOOP CLOCK DRIVER
WITH 2-LINE SERIAL INTERFACE

SCAS647B – OCTOBER 2000 – REVISED DECEMBER 2002

PARAMETER MEASUREMENT INFORMATION

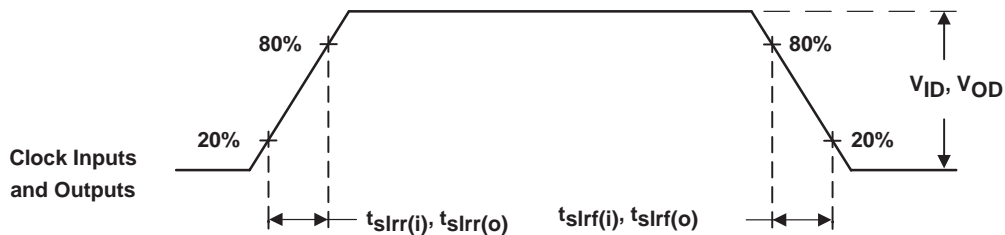

Figure 8. Input and Output Slew Rates

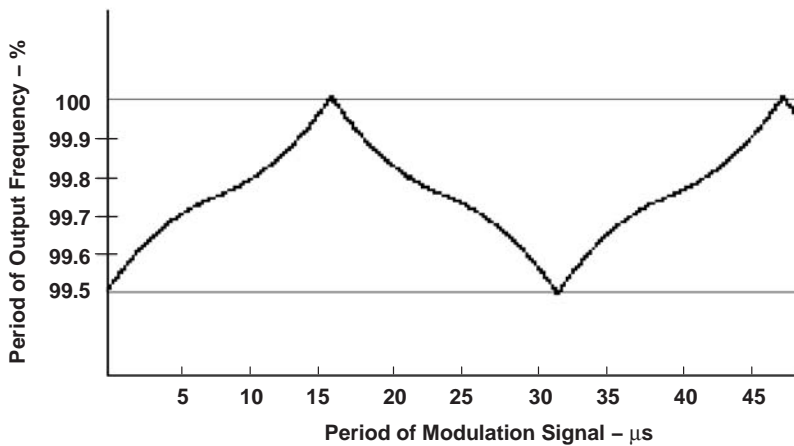

Figure 9. SSC Modulation Profile

CDCV850, CDCV850I

2.5-V PHASE LOCK LOOP CLOCK DRIVER

WITH 2-LINE SERIAL INTERFACE

SCAS647B – OCTOBER 2000 – REVISED DECEMBER 2002

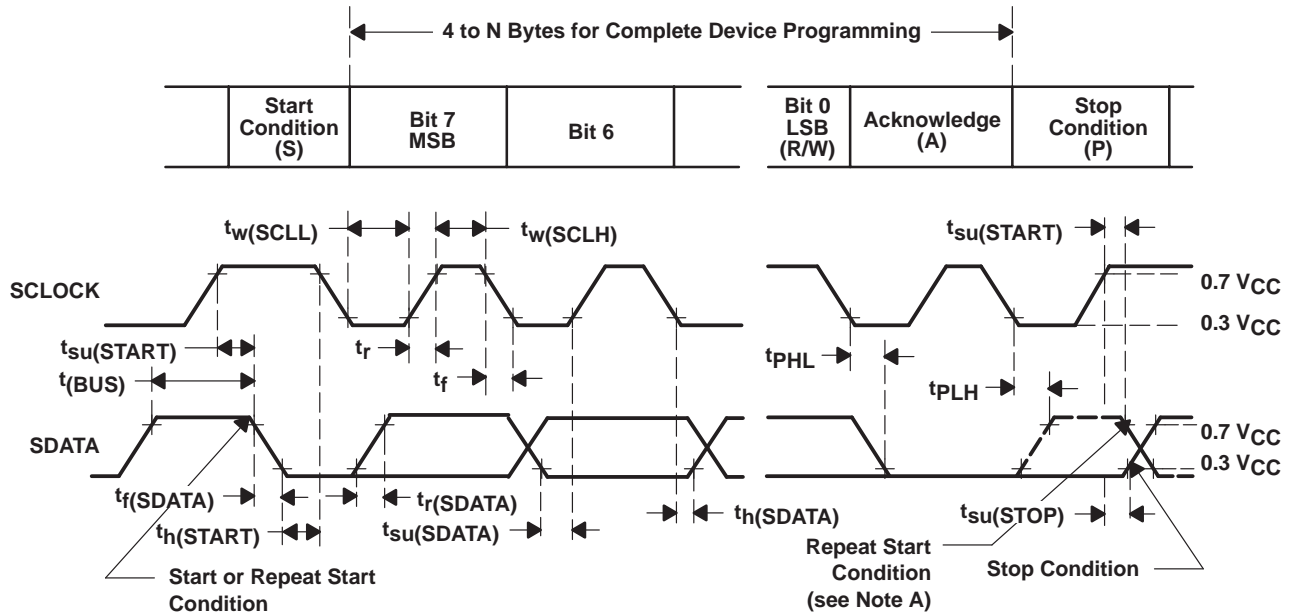
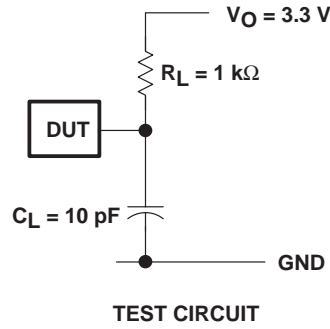

BYTE	DESCRIPTION
1	Slave Address
2	Common (Dummy Value, Ignored)
3	Byte Count = N
4	Data Byte 0
5 – N	Data Byte 1 – N

NOTE A: The repeat start condition is supported. If PWRDWN# is asserted SDATA will be set to off-state, high impedance.

Figure 10. Propagation Delay Times, t_r and t_f

CDCV850, CDCV850I
2.5-V PHASE LOCK LOOP CLOCK DRIVER
WITH 2-LINE SERIAL INTERFACE

SCAS647B – OCTOBER 2000 – REVISED DECEMBER 2002

MECHANICAL DATA

48 PINS SHOWN

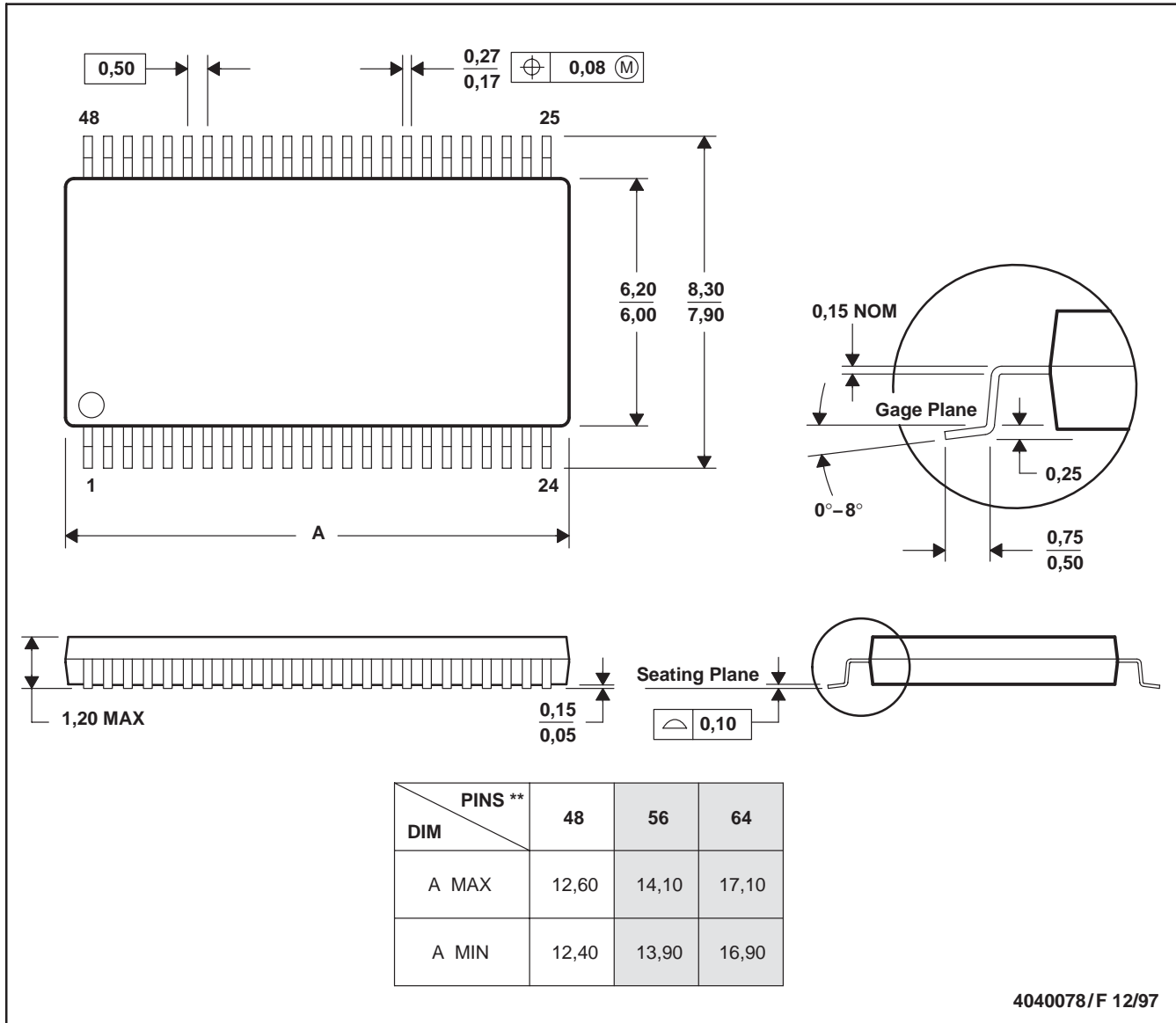

- NOTES: B. All linear dimensions are in millimeters.
 C. This drawing is subject to change without notice.
 D. Body dimensions do not include mold protrusion not to exceed 0,15.
 E. Falls within JEDEC MO-153

IMPORTANT NOTICE

Texas Instruments Incorporated and its subsidiaries (TI) reserve the right to make corrections, modifications, enhancements, improvements, and other changes to its products and services at any time and to discontinue any product or service without notice. Customers should obtain the latest relevant information before placing orders and should verify that such information is current and complete. All products are sold subject to TI's terms and conditions of sale supplied at the time of order acknowledgment.

TI warrants performance of its hardware products to the specifications applicable at the time of sale in accordance with TI's standard warranty. Testing and other quality control techniques are used to the extent TI deems necessary to support this warranty. Except where mandated by government requirements, testing of all parameters of each product is not necessarily performed.

TI assumes no liability for applications assistance or customer product design. Customers are responsible for their products and applications using TI components. To minimize the risks associated with customer products and applications, customers should provide adequate design and operating safeguards.

TI does not warrant or represent that any license, either express or implied, is granted under any TI patent right, copyright, mask work right, or other TI intellectual property right relating to any combination, machine, or process in which TI products or services are used. Information published by TI regarding third-party products or services does not constitute a license from TI to use such products or services or a warranty or endorsement thereof. Use of such information may require a license from a third party under the patents or other intellectual property of the third party, or a license from TI under the patents or other intellectual property of TI.

Reproduction of information in TI data books or data sheets is permissible only if reproduction is without alteration and is accompanied by all associated warranties, conditions, limitations, and notices. Reproduction of this information with alteration is an unfair and deceptive business practice. TI is not responsible or liable for such altered documentation.

Resale of TI products or services with statements different from or beyond the parameters stated by TI for that product or service voids all express and any implied warranties for the associated TI product or service and is an unfair and deceptive business practice. TI is not responsible or liable for any such statements.

Following are URLs where you can obtain information on other Texas Instruments products and application solutions:

Products		Applications	
Amplifiers	amplifier.ti.com	Audio	www.ti.com/audio
Data Converters	dataconverter.ti.com	Automotive	www.ti.com/automotive
DSP	dsp.ti.com	Broadband	www.ti.com/broadband
Interface	interface.ti.com	Digital Control	www.ti.com/digitalcontrol
Logic	logic.ti.com	Military	www.ti.com/military
Power Mgmt	power.ti.com	Optical Networking	www.ti.com/opticalnetwork
Microcontrollers	microcontroller.ti.com	Security	www.ti.com/security
		Telephony	www.ti.com/telephony
		Video & Imaging	www.ti.com/video
		Wireless	www.ti.com/wireless

Mailing Address: Texas Instruments
Post Office Box 655303 Dallas, Texas 75265

Copyright © 2003, Texas Instruments Incorporated