

CP300 THRU CP3010

SINGLE-PHASE SILICON BRIDGE-P.C. MTG 2A, HEAT-SINK MTG 3A
VOLTAGE - 50 to 1000 Volts CURRENT - 3.0 Amperes

CP-3

 Recognized File #E111753

FEATURES

- Surge overload rating—50 Amperes peak
- Low forward voltage drop and reverse leakage
- Small size, simple installation
- Plastic package has Underwriter Laboratory Flammability Classification 94V-O
- Reliable low cost construction utilizing molded plastic technique

MECHANICAL DATA

Terminals: Leads solderable per MIL-STD-202,
 Method 208

Weight: 0.08 ounce, 2.5 grams

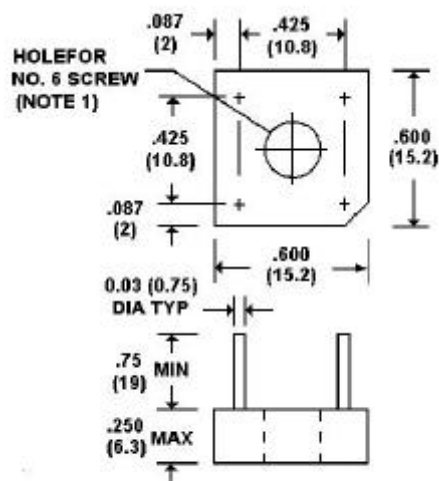

MAXIMUM RATINGS AND ELECTRICAL CHARACTERISTICS

At 25 °C ambient temperature unless otherwise noted; resistive or inductive load at 60Hz.

	CP300	CP301	CP302	CP304	CP306	CP308	CP3010	UNITS
Max Recurrent Peak Rev Voltage	50	100	200	400	600	800	1000	V
Max Bridge Input Voltage RMS	35	70	140	280	420	560	700	V
Max Average Rectified Output at $T_C=50\text{ }^{\circ}\text{C}$ * See Fig.2 at $T_A=25\text{ }^{\circ}\text{C}$ **	3.0							A
Peak One Cycle Surge Overload Current	50							A
Max Forward Voltage Drop per element at 1.5A DC & 25 °C. See Fig.3	1.0							V
Max Rev Leakage at Rated DC Blocking Voltage per element at 25 °C See Fig.4 at 100 °C	10.0							µg A
	1.0							mA
I ² t Rating for fusing (t<8.3ms)	15.0							A ² Sec
Typical Junction capacitance per leg(Note 4)C _J	21.0							pF
Typical Thermal Resistance per leg(Note 2) R _{θKJA} (Note 3) R _{θKJL}	12.0							°C/W
	8.0							
Operating Temperature Range	-55 TO +125							°C
Storage Temperature Range	-55 TO +150							°C

NOTES:

1. Bolt down on heat-sink with silicon thermal compound between bridge and mounting surface for maximum heat transfer with #6 screw.
2. Unit mounted on 4.0 i ñ 4.0 i ñ 0.11" thick (10.5 i ñ 10.5 i ñ 0.3cm) AL. Plate.
3. Unit mounted on P.C.B at 0.375"(9.5mm) lead length with 0.5 i ñ 0.5" (12 i ñ 12mm) copper pads.
4. Measured at 1 MHz and applied reverse voltage of 4.0 Volts.

RATING AND CHARACTERISTIC CURVES

CP300 THRU CP3010

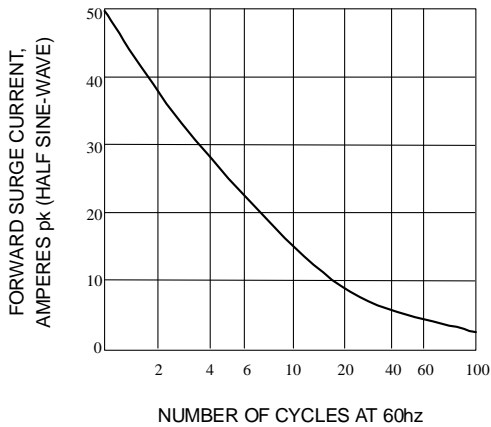

Fig. 1- NON-RECURRENT SURGE RATING

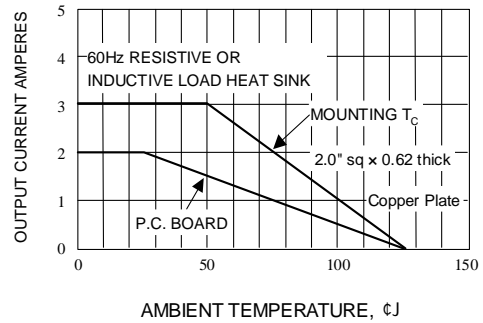

Fig. 2- DERATING CURVE FOR OUTPUT RECTIFIED CURRENT

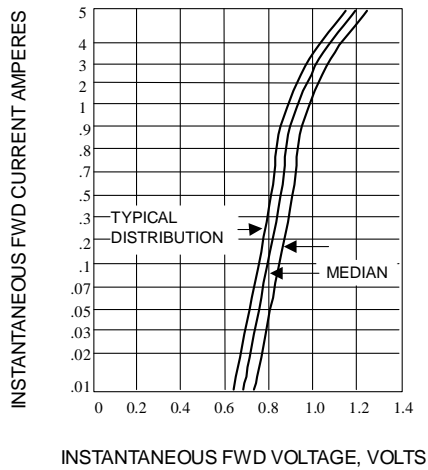

Fig. 3- TYPICAL FORWARD CHARACTERISTICS (25°C)

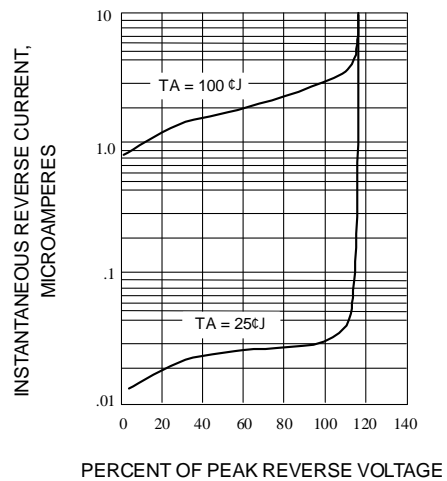

Fig. 4- TYPICAL REVERSE CHARACTERISTICS