

Switching Regulator Power Controller

Features

- Wide supply voltage operating range: 1.8 to 13 V
- Low current consumption: Typically 5.5 mA in operation, 1 μ A or less in stand-by
- High speed operation is possible: Maximum 1 MHz
- The error amplifier gain is set inside the IC, so peripheral components are minimized.
- Incorporates a soft start circuit.
- Incorporates a timer-latch type short circuit detection circuit (SCP).
- Totem-pole type output with adjustable on/off current (for NPN transistors)
- Incorporates a stand-by function.

Applications

- Power source for battery-powered equipment
- Power source for cameras, camcorders, VCRs, PDAs, electronic data banks, and hand-held Communication equipment

General Description

The CP3800 is a single-channel switching regulator control IC for low voltage applications incorporating a soft start function and short circuit detection function. The device has a low minimum operating voltage of 1.8 V and is ideal for the power supply of battery-operated electronic equipment.

The CP3800 can be operated on two types: non-insulated input/output choppers (step-up, step-down), and insulated input/output converters (fly-back). The former type is used for DC/DC converters and the latter type is used for DC/DC converts and line-operation-type power supplies.

Block Diagram

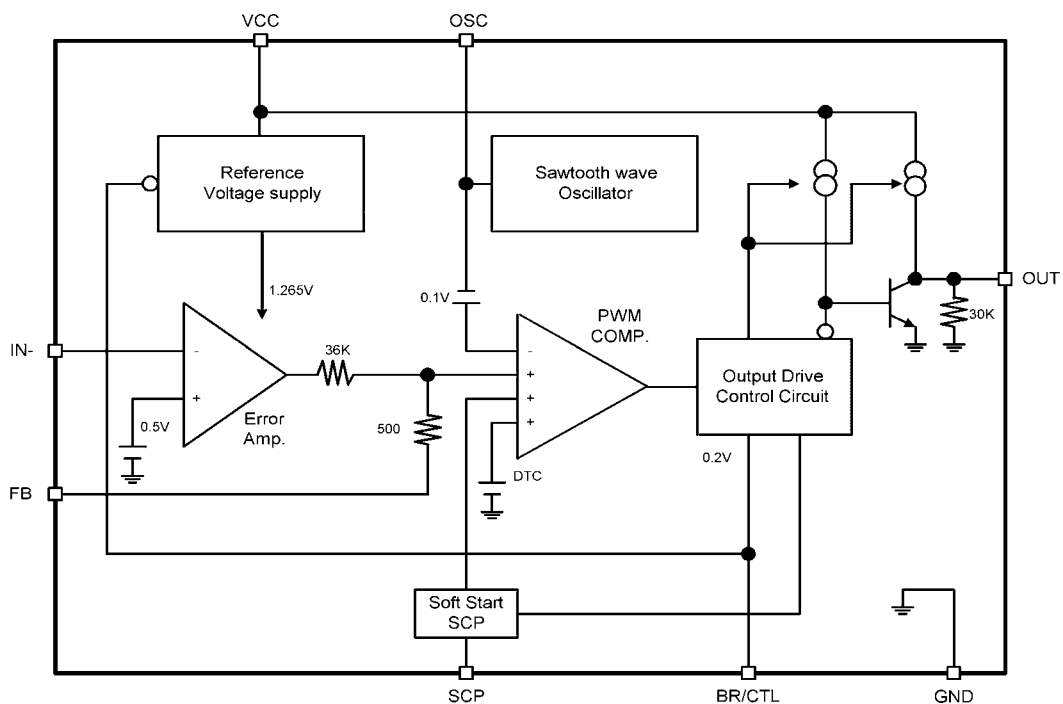

* All specs and applications shown above subject to change without prior notice.

Switching Regulator Power Controller

Pin Configuration

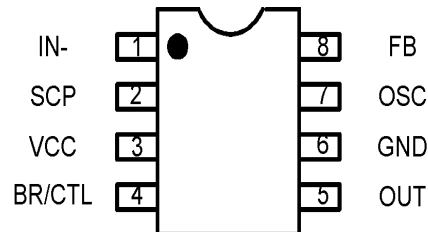

Ordering Information

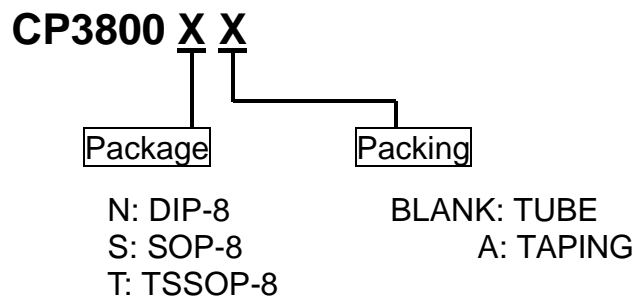

Pin Description

Pin No.	Symbol	I/O	Description
1	IN-	I	Error amplifier inverting input pin
2	SCP	—	Soft start and SCP setting capacitor connection pin
3	VCC	—	Power supply pin
4	BR/CTL	I	Output current setting and control pin
5	OUT	O	Totem-pole type output pin
6	GND	—	Ground pin
7	OSC	—	Capacitor and resistor connection pin for setting the oscillation frequency
8	FB	O	Error amplifier output pin

* All specs and applications shown above subject to change without prior notice.

Switching Regulator Power Controller

Absolute Maximum Ratings

(T_v=+25°C)

Parameter	Symbol	Condition	Rated Value		Unit
			Min.	Max.	
Power supply voltage	V _{CC}	—	—	3	V
Output source current	I _O ⁺	—	—	-50	mA
Output sink current	I _O ⁻	—	—	50	mA
Allowable dissipation	P _D	SOP-8, Ta ≤ +25°C	—	570	mW
	P _D	TSSOP-8, Ta ≤ +25°C	—	430	mW
Operating temperature	T _{OP}	—	-30	+85	°C
Storage temperature	T _{stg}	—	-55	+125	°C
ESD Classification		MIL-STD-883	Class 2		

* : When mounted on a 10 cm square double-sided epoxy board

WARNING: Semiconductor devices can be permanently damaged by application of stress (voltage, current, temperature, etc.) in excess of absolute maximum ratings. Do not exceed these ratings.

Recommended Operating Conditions

(Ta=+25°C)

Parameter	Symbol	Values			Unit
		Min.	Typ.	Max.	
Power supply voltage	V _{CC}	1.8	--	12.0	V
Error amplifier input voltage	V _I	-0.2	--	1.0	V
BR/CTL pin input voltage	V _{BR}	-0.2	--	V _{CC}	V
Output source current	I _O ⁺	-20	--	--	mA
Output sink current	I _O ⁻	--	--	40	mA
SCP pin capacitance	C _{PE}	--	0.1	--	μF
Phase compensation capacitance	C _P	--	0.1	--	μF
Output current setting resistance	R _B	150	390	5000	Ω
Timing resistance	R _T	1.0	3.0	10.0	kΩ
Timing capacitance	C _T	100	270	10000	pF
Oscillation frequency	f _{OSC}	10	500	1000	kHz
Operating temperature	T _{OP}	-30	+25	+85	°C

WARNING: Recommended operating conditions are normal operating ranges for the semiconductor device. All the device's electrical characteristics are warranted when operated within these ranges. Always use semiconductor devices within the recommended operating conditions. Operation outside these ranges may adversely affect reliability and could result in device failure.

* All specs and applications shown above subject to change without prior notice.

Switching Regulator Power Controller
Electrical Characteristics

 (V_{CC}=+2V, Ta=+25°C)

Parameter		Symbol	Condition	Values			Unit	
				Min.	Typ.	Max.		
Circuit to prevent malfunction at low input voltage (U.V.L.O.)	Reset voltage	V _R	--	--	--	0.9	V	
	Threshold voltage	V _{TH}		1.1	1.3	1.5	V	
Soft start	Charging current	I _{CS}	V _{SCP} =0V	-1.5	-1.0	-0.7	μA	
	Voltage at soft start completion	V _{IS}	--	0.7	0.8	0.9	V	
Short circuit detection (S.C.P.)	Charging current	I _{CPC}	V _{SCP} =0V	-1.5	-1.0	-0.7	μA	
	Threshold voltage	V _{IPC}	--	0.7	0.8	0.9	V	
Sawtooth wave oscillator (OSC)	Oscillation frequency	f _{OSC}	R _T =3.3kΩ, C _T =270pF	400	500	600	kHz	
	Frequency input Stability	f _{dV}	V _{CC} =2V to 12V	--	2	10	%	
	Frequency variation with temperature	f _{dT}	Ta = -30°C to 85°C	--	5	--	%	
Error amplifier	Input threshold Voltage	V _T	V _{FB} = 450mV	480	500	520	mV	
	V _T input stability	V _{TdV}	V _{CC} =2V to 12V	--	5	20	mV	
	V _T variation with Temperature	V _{TdT}	Ta = -30°C to 85°C	--	1	--	%	
	Input bias current	I _B	V _{IN} = 0V	-1.0	-0.2	1.0	μA	
	Voltage gain	A _V	--	70	100	145	V/V	
	Frequency bandwidth	BW	A _V = 0 dB	--	6	--	MHz	
	Maximum output voltage range	V _{OM} ⁺	--	--	0.78	0.87	--	V
		V _{OM} ⁻			--	0.05	0.2	V
Output source current	I _{OM} ⁺	V _{FB} = 450mV	--	-40	-24	μA		
Output sink current	I _{OM} ⁻	--	24	40	--	μA		
Idle period adjustment section	Maximum duty cycle	T _{DUTY}	R _T =3.3kΩ, C _T =270pF f _{OSC} = 500KHz	75	--	85	%	
Output section	Output voltage	V _{OH1}	R _B = 390Ω, I _O = -15 mA	1.0	1.2	--	V	
		V _{OH2}	R _B = 750Ω, V _{CC} = 1.8V I _O = -10 mA	0.8	1.0	--	V	
		V _{OL1}	R _B = 390Ω, I _O = -15 mA	--	0.1	0.2	V	
		V _{OL2}	R _B = 750Ω, V _{CC} = 1.8V I _O = -10 mA	--	0.1	0.2	V	
	Output source current	I _O ⁺	R _B = 390Ω, V _O = 0.9V	--	-30	-20	mA	
	Output sink current	I _O ⁻	R _B = 390Ω, V _O = 0.3V	30	60	--	mA	
	Pull down resistance	R _O	--	20	30	40	kΩ	

* All specs and applications shown above subject to change without prior notice.

Switching Regulator Power Controller

Output current Setting section/ Control section	Pin voltage	V_{BR}	$R_B = 390\ \Omega$	0.10	0.19	0.25	V
	Input off condition	I_{OFF}	--	-20	--	0	μA
	Input on condition	I_{ON}	--	--	--	-45	μA
	Pin current range	I_{BR}	--	-1.8	--	-0.1	m A
Entire device	Stand-by current	I_{CCS}	BR/CTL pin open or V_{CC}	--	--	1	μA
	Average supply current	I_{CC}	$R_B = 390, V_{CC} = 2 \sim 12V$	--	5.5	10.0	m A

Timing Chart

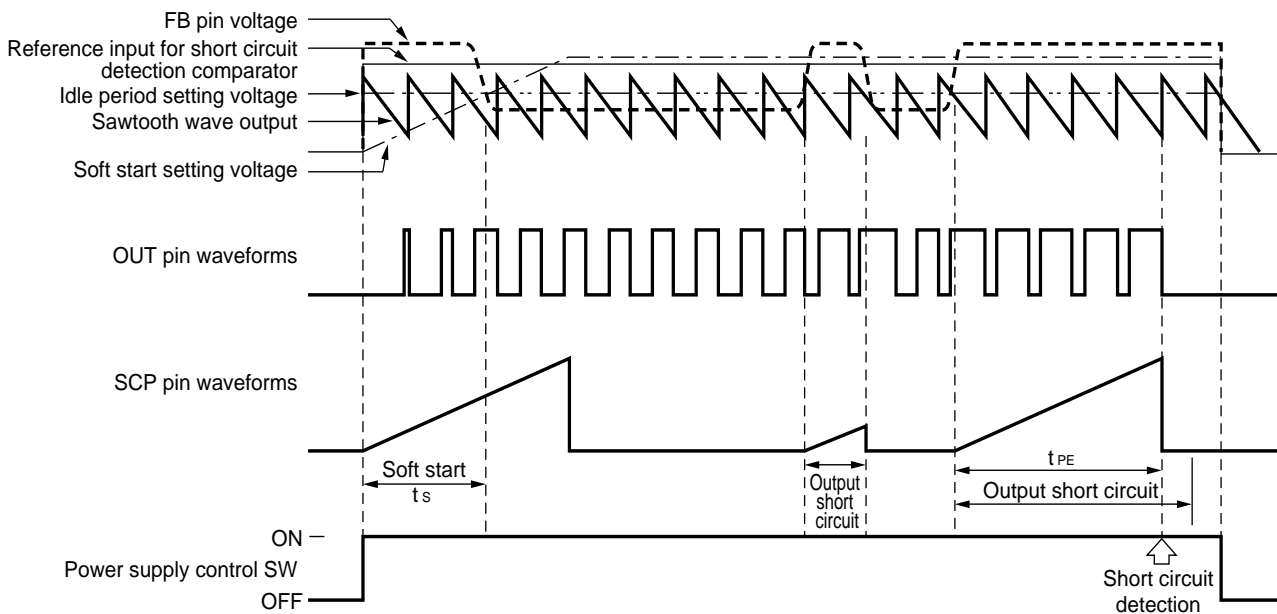

* All specs and applications shown above subject to change without prior notice.

Switching Regulator Power Controller

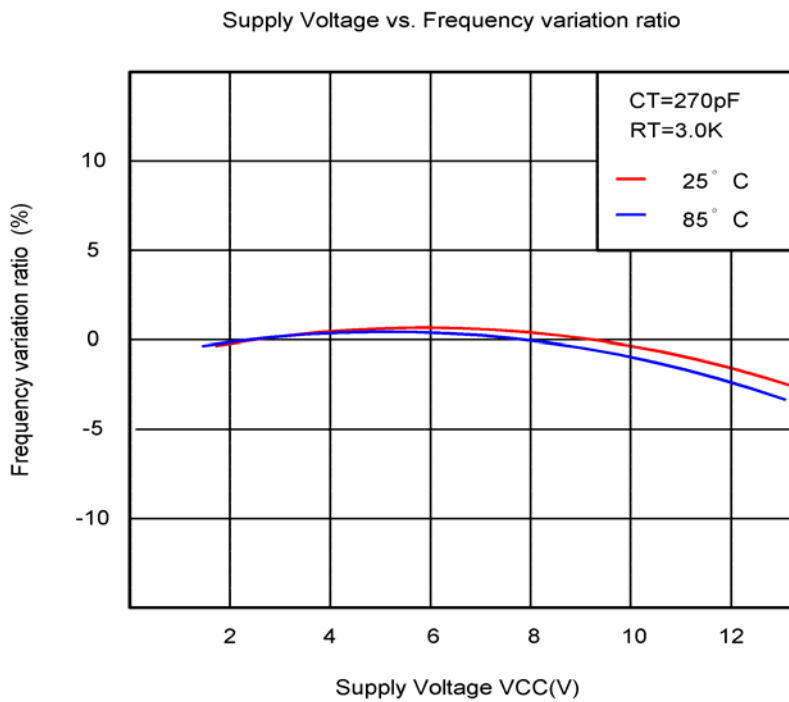
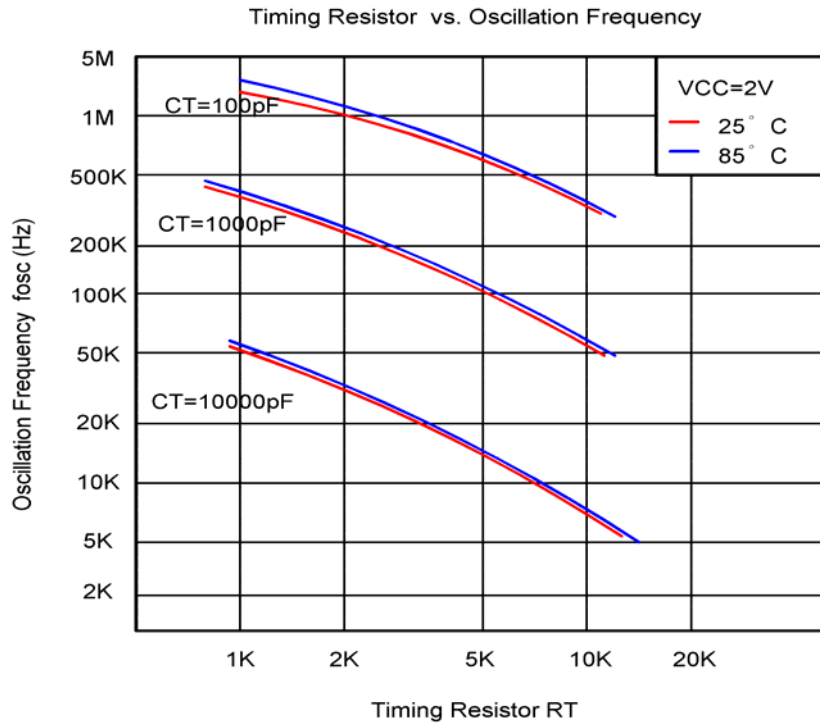

* All specs and applications shown above subject to change without prior notice.

Switching Regulator Power Controller

Supply Voltage vs. Supply Current

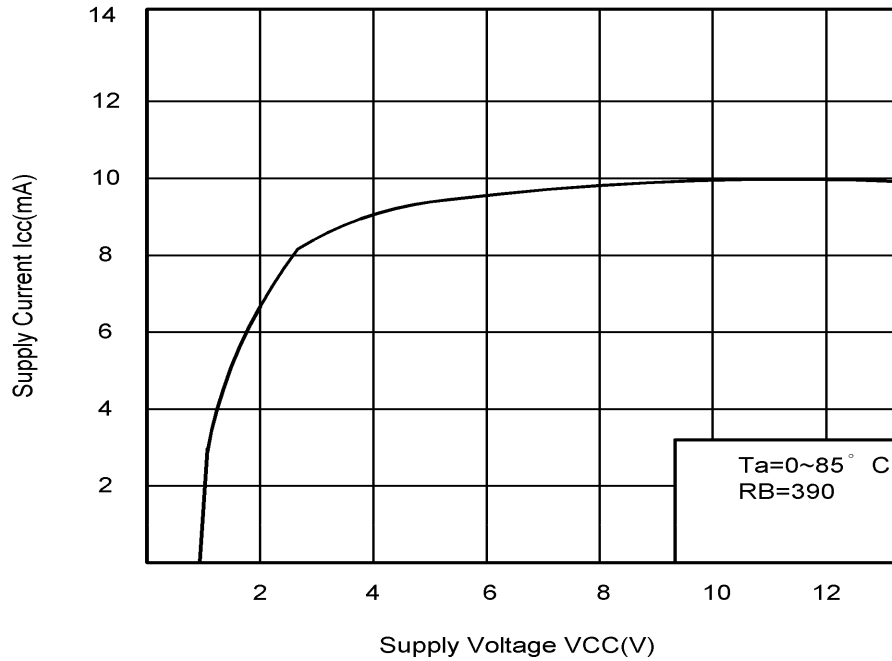

Supply Voltage vs. Input Threshold voltage

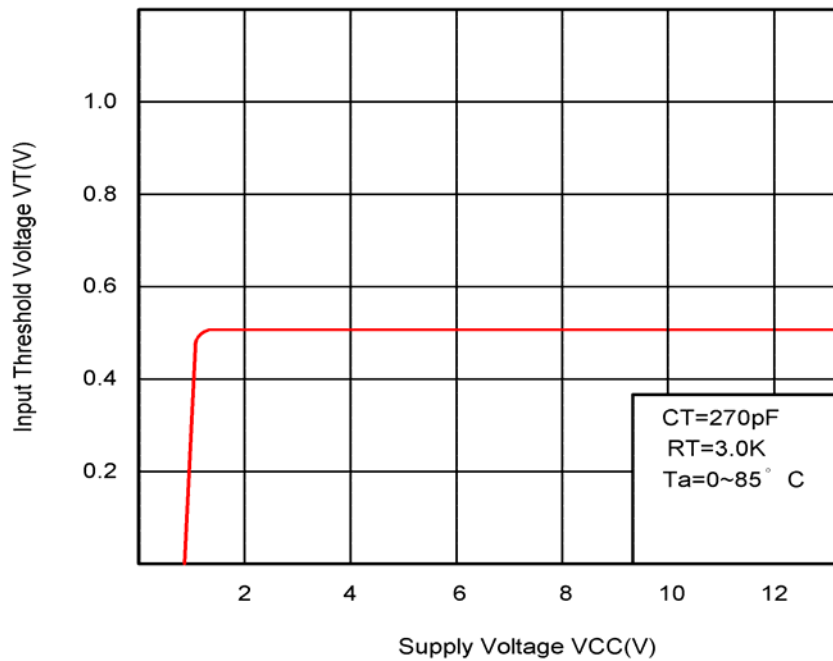

* All specs and applications shown above subject to change without prior notice.

Switching Regulator Power Controller

Ambient Temperature vs. Input Threshold Voltage
Variation ratio

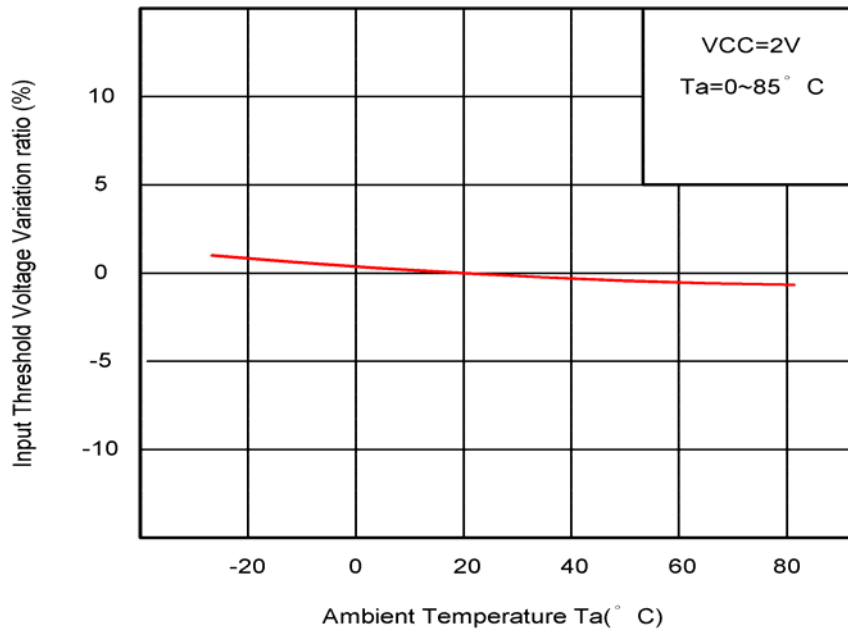

Ambient Temperature vs. Frequency variation ratio

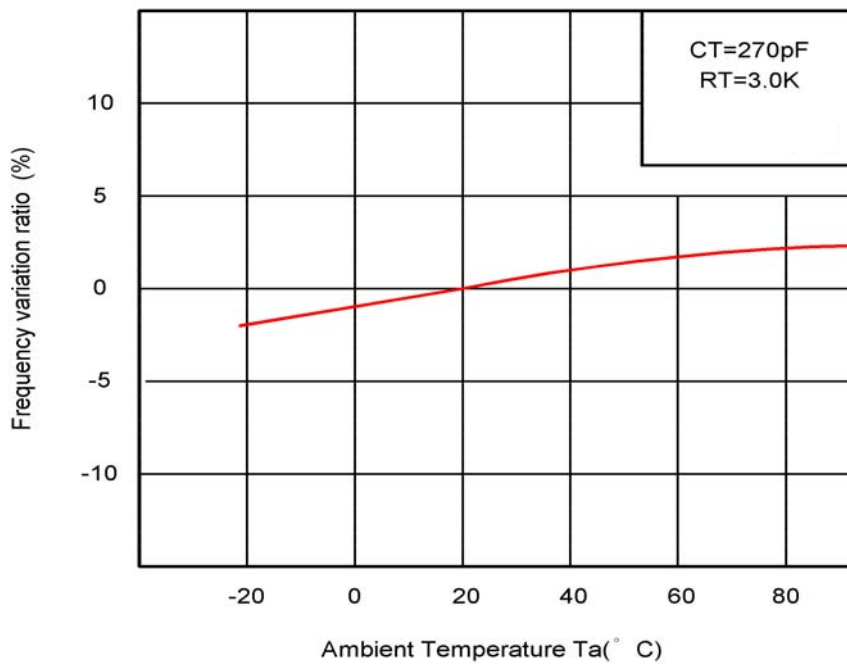

* All specs and applications shown above subject to change without prior notice.

Switching Regulator Power Controller

High Level Output Characteristic

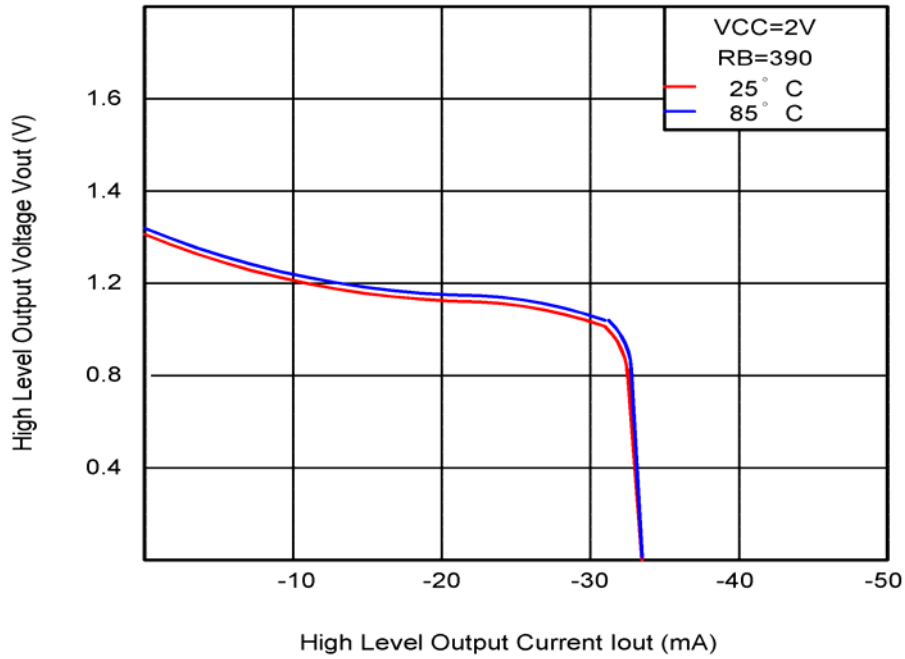

Low Level Output Characteristic

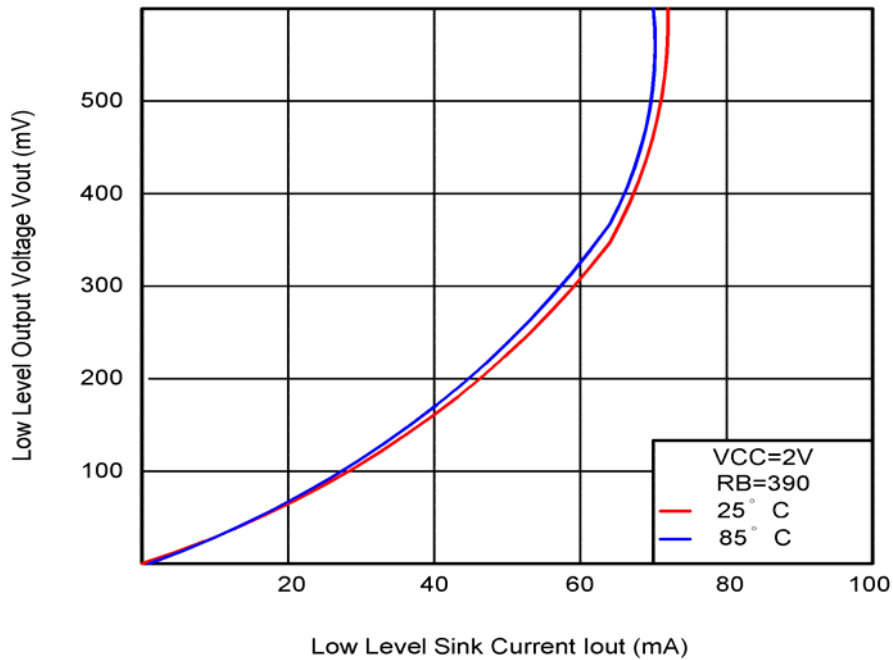

* All specs and applications shown above subject to change without prior notice.

Switching Regulator Power Controller

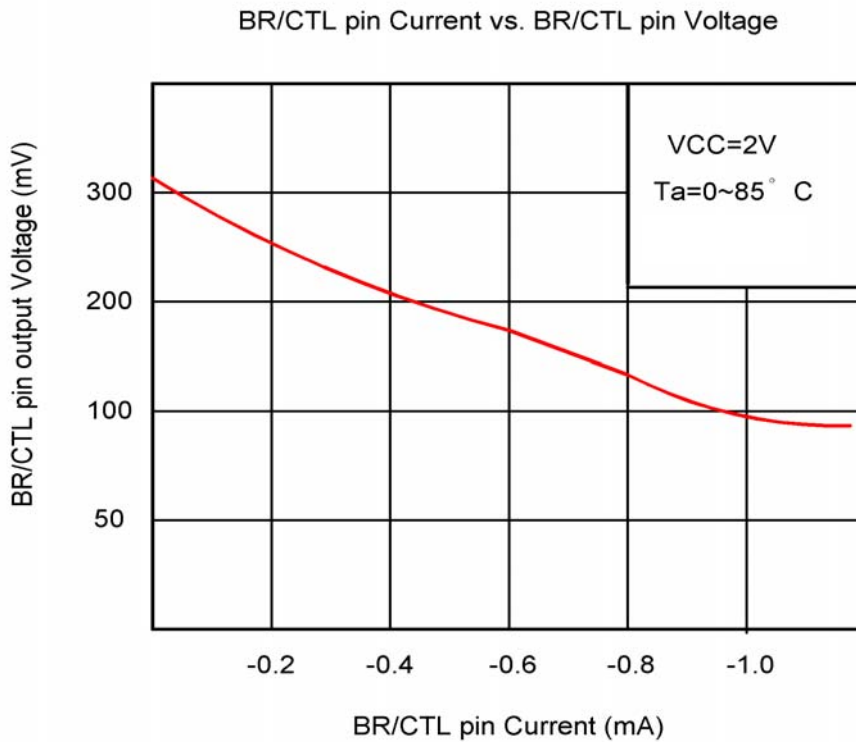
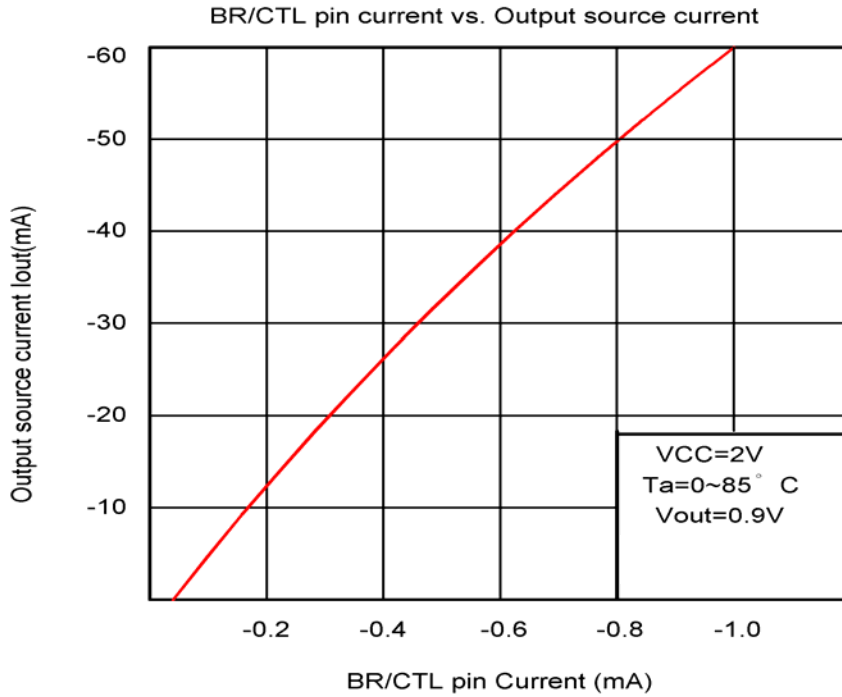

* All specs and applications shown above subject to change without prior notice.

Switching Regulator Power Controller

Typical Application Schematic

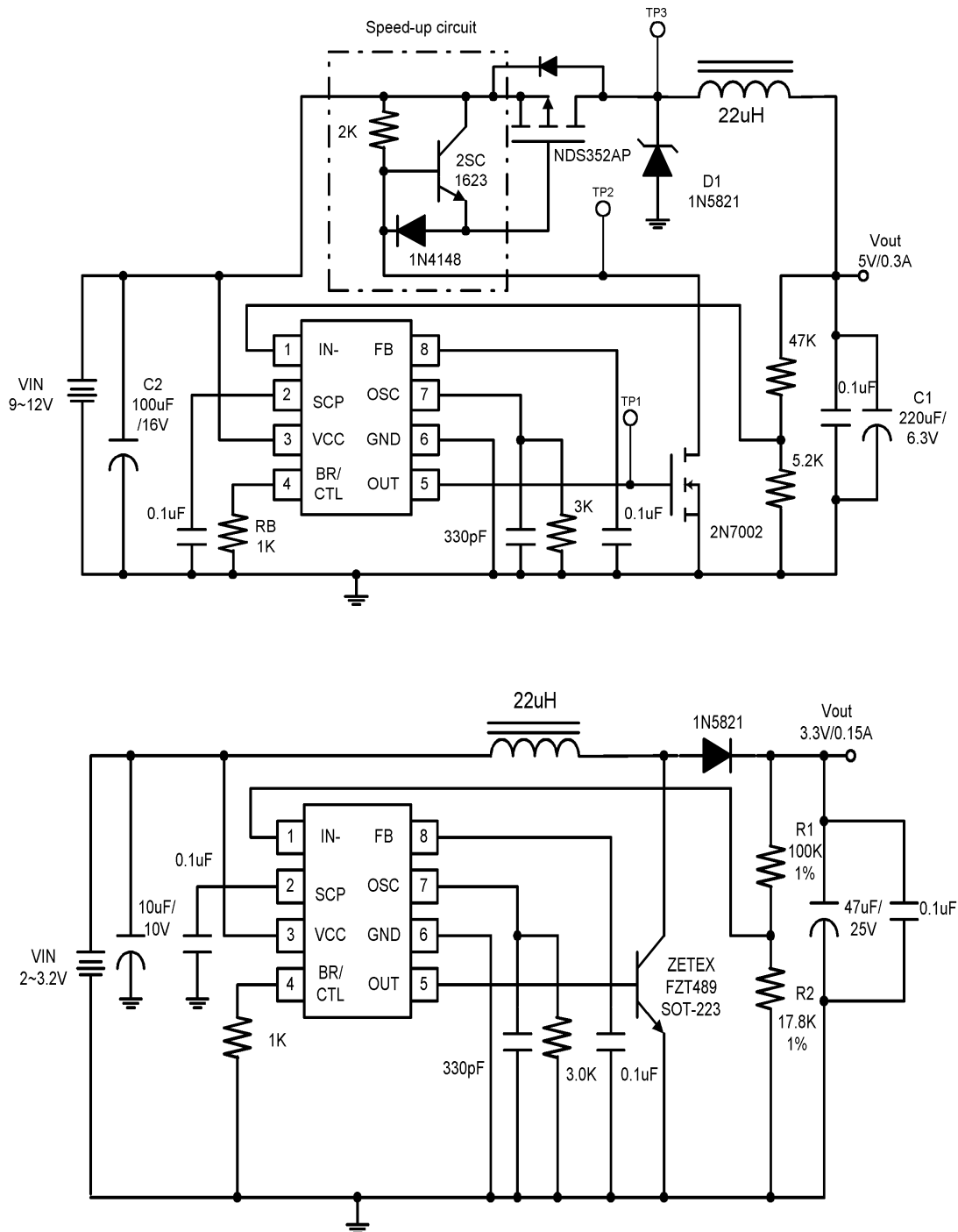

* All specs and applications shown above subject to change without prior notice.

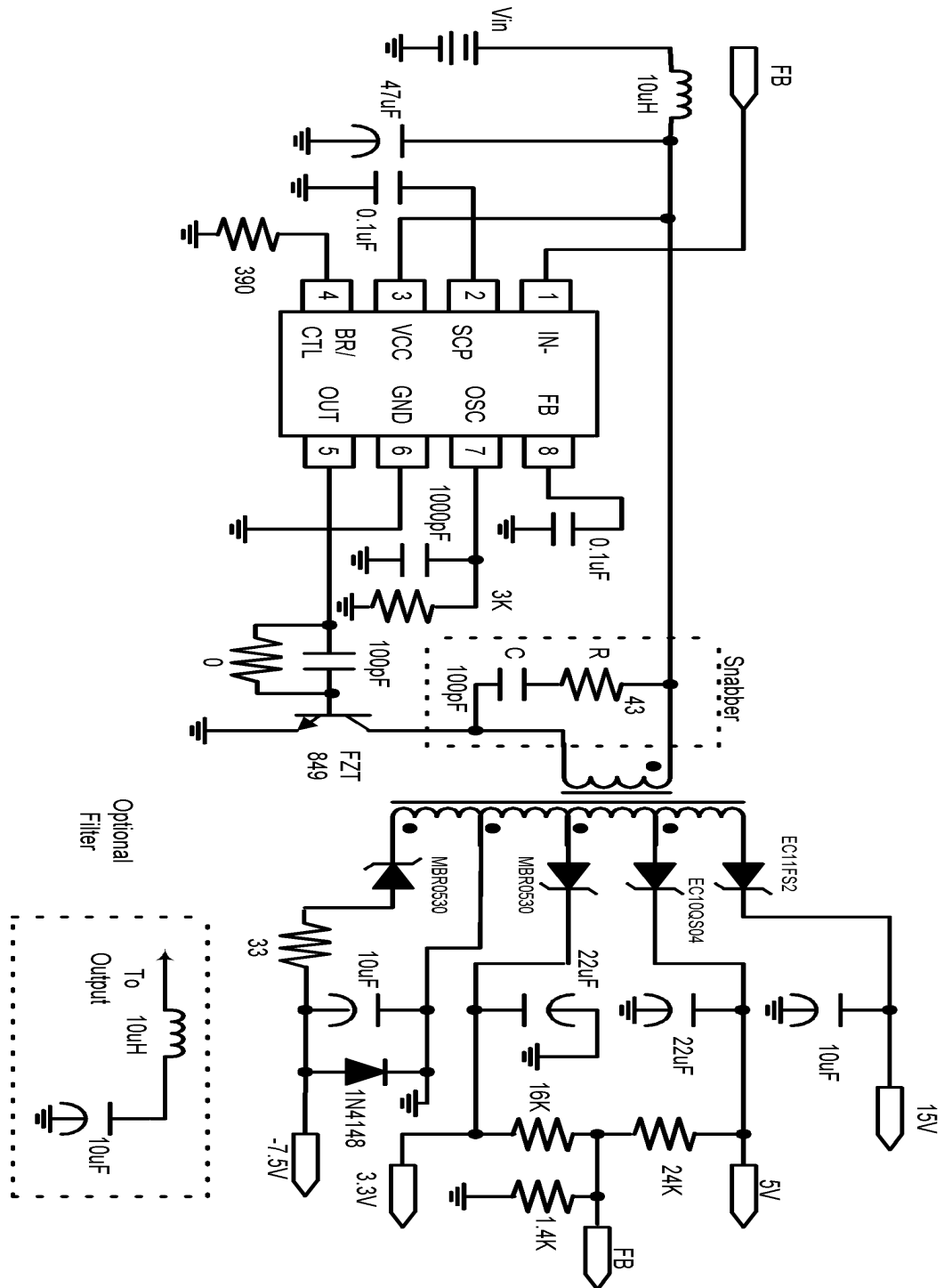
Switching Regulator Power Controller

* All specs and applications shown above subject to change without prior notice.

Switching Regulator Power Controller

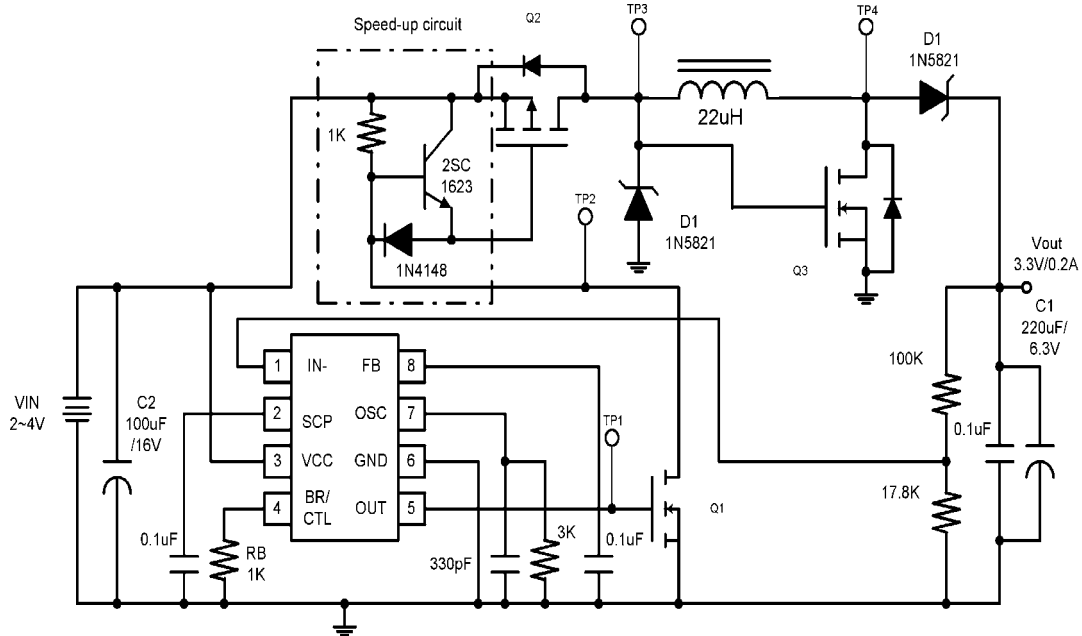

*Q1,Q2,Q3 Low VT MOSFET
or use Transistor NPN & PNP

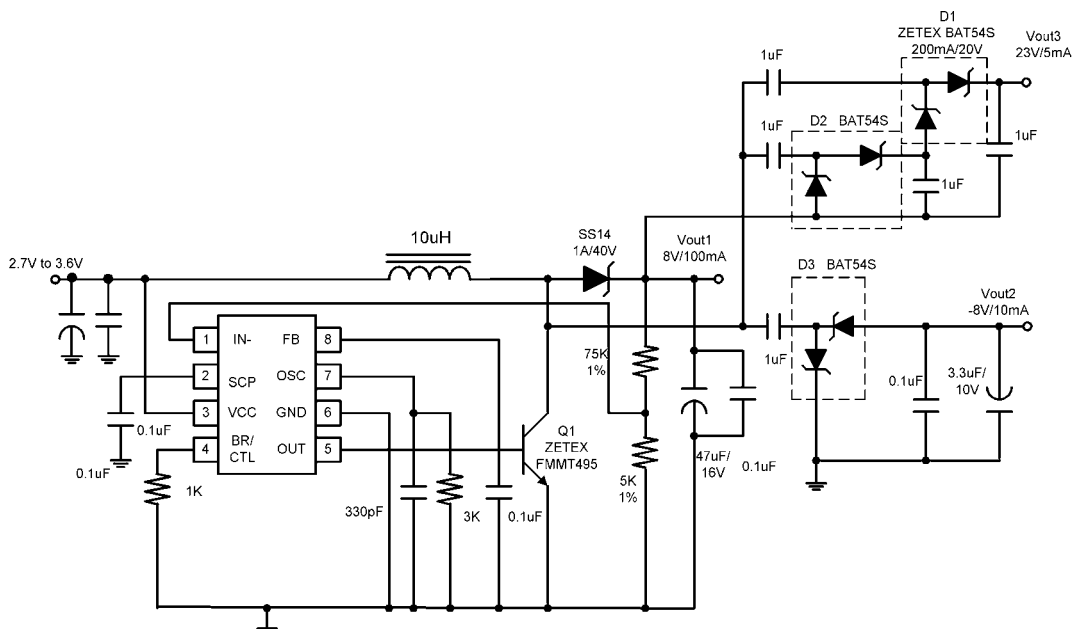

1. Q1 can use low threshold VT N Channel MOSFET (NDS339AN)
2. Vout2 and Vout3 outputs are unregulated (can use zener diode to regulate it)
3. $V_{out3} = V_{out1} * 3 - V_{diode} * 3$ (V_{diode} is Schottky Diode forward drop voltage)
4. Operation frequency 500-600KHz

* All specs and applications shown above subject to change without prior notice.

Switching Regulator Power Controller

Functional Description

Soft Start SCP

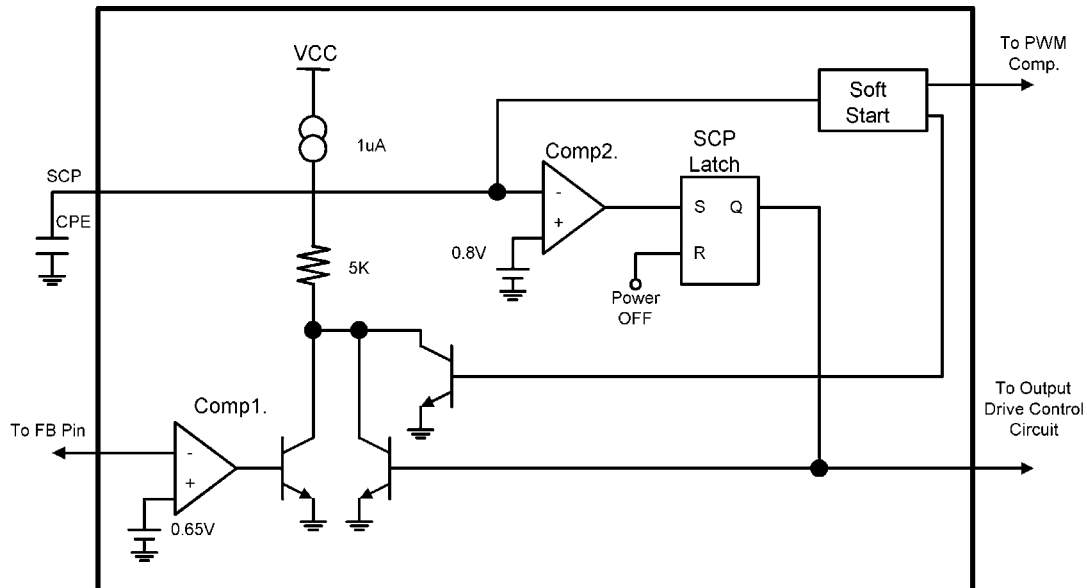

Figure 1 Soft-Start SCP Equivalent circuit

At power-on, the CP3800 operates in the soft-start mode. Since no current is supplied, comp1, comp2, and SCP latch are inactive. Immediately after power-on, the CPE capacitor is charged at a constant current of $1\mu\text{A}$ to increase from 0V. In the soft-start mode, the VSCP (capacitor CPE voltage) is input to the PWM comparator, so that the soft-start circuit is controlled at the on-duty ratio of 0% with the increase of the VSCP.

When the VSCP reaches 0.8V, the soft-start supplies current to comp1, comp2, and SCP latch and at the same time discharges the CPE capacitor (VSCP=0V). This changes the soft-start mode to the normal mode (output short circuit detection wait state) and the SCP becomes active (stays low). In the normal mode, the input from the soft-start circuit to the PWM comparator is kept at 0.8V.

If the switching regulator output suddenly drops due to load effect, the error amplifier output (FB pin) is fixed at V_{OM}^+ and capacitor CPE starts charging. When the voltage at the SCP pin reaches approximately 0.8V, the output pin is set low and the SCP pin stays low.

Set time by the following expressions (see **Timing Chart**):

Soft-Start time (The time until the output ON duty reaches approximately 50%)

* All specs and applications shown above subject to change without prior notice.

Switching Regulator Power Controller

$$t_S = 0.35 \times CPE(\mu F)$$

Short-circuit detection time(or Soft-Start full time) :

$$t_{PE} = 0.8 \times CPE(\mu F)$$

Setting Oscillating Frequency

The oscillation frequency of a sawtooth waveform is determined by the timing capacitor (CT) and the timing resistor (RT) which are connected to the OSC pin. When the voltage of the OSC pin falls to 0.1V, the CT is rapidly charged to increase the voltage of the OSC pin instantaneously. When the voltage of the OSC pin reaches 0.8V, Charging stops, so that CT and RT are discharged to decrease the voltage of the OSC pin. The waveform of the OSC pin is shown as Figure 2.

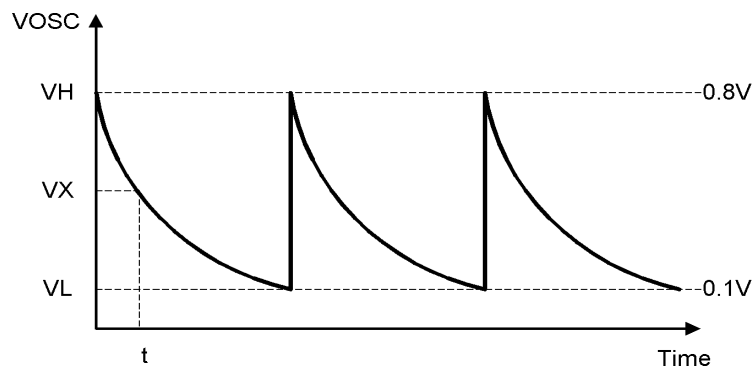

Figure 2 Oscillator Waveform

The cycle (T) can be determined as follows:

$$VX = VHe^{-\frac{t}{CT \times RT}} \quad t = -CT \times RT \times \log_e\left(\frac{VX}{VH}\right)$$

$$T = -CT \times RT \times \log_e(0.1/0.8) = 2.1 \times CT \times RT [s]$$

Calculating under the conditions of RT=3.0KΩ and CT=270pF , the oscillating frequency is 588kHz, which is slightly different from the value (600kHz) in the **Electrical Characteristics**. This difference is caused by characteristics, such as changes in the maximum voltage amplitude of the sawtooth waveform with the CT value and the circuit delay causing the maximum amplitude to become large in the case of a high oscillating frequency even for the same capacitor. It is difficult to incorporate these non-linear characteristics into the equation. In practical use, therefore, the user should read the RT and CT values from the characteristic curve or should determine an approximate target value by using the equation.

* All specs and applications shown above subject to change without prior notice.

Switching Regulator Power Controller

Switching Regulator Function

(1) Reference voltage circuit

The reference voltage circuit generates a temperature-compensated reference voltage (~1.25V) from voltage supplied from the power supply pin (pin 3). In addition to providing the reference voltage for the switching regulator, the circuit also sets the idle period.

(2) Error amplifier

The error amplifier detects the output voltage of the switching regulator and outputs the PWM control signal. The voltage gain is fixed, and connecting a phase compensation capacitor to the FB pin (pin 8) provides stable phase compensation for the system.

(3) PWM comparator

The voltage comparator has one inverting and three non-inverting inputs. The comparator is a voltage/pulse width converter that controls the ON time of the output pulse depending on the input voltage. The output level is high (H) when the sawtooth wave is lower than the error amplifier output voltage, soft start setting voltage, and idle period setting voltage.

(4) Output circuit

The output circuit has a totem pole type configuration and can drive an external NPN transistor directly. The value of the ON/OFF current can be set by a resistor connected to the BR/CTL pin (pin 4). Stand-by mode (supply current 1 μ A or less) can be set by connecting the BR/CTL pin (pin4) to VCC or by making the pin open circuit.

(5) Under-Voltage Lockout (UVLO)

Transients when powering on or instantaneous glitches in the supply voltage can lead to malfunction of the control IC and cause system damage or failure. The circuit to prevent malfunction at low input voltage detects a low input voltage by comparing the supply voltage to the internal reference voltage. On detection, the circuit fixes the output pin to low.

To cancel the status, set VCC below the reset voltage VR (0.9V) and then set VCC up to the recommended operation condition range. By the operation, the latch is canceled to start to operate normally.

* All specs and applications shown above subject to change without prior notice.

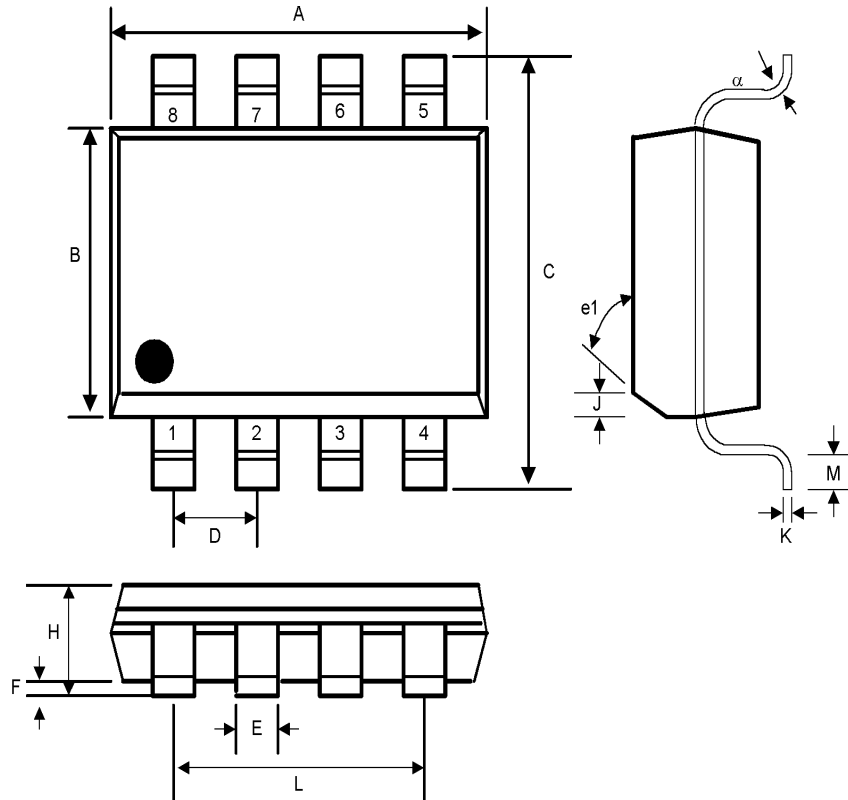
Switching Regulator Power Controller
Small Outline 8-pin Plastic SOP

SYMBOL	INCHES		MILLIMETERS		NOTES
	MIN	MAX	MIN	MAX	
A	0.188	0.197	4.80	5.00	-
B	0.149	0.158	3.80	4.00	-
C	0.228	0.244	5.80	6.20	-
D	0.050	BSC	1.27	BSC	-
E	0.013	0.020	0.33	0.51	-
F	0.004	0.010	0.10	0.25	-
H	0.053	0.069	1.35	1.75	-
J	0.011	0.019	0.28	0.48	-
K	0.007	0.010	0.19	0.25	-
M	0.016	0.050	0.40	1.27	-
L	0.150	REF	3.81	REF	-
e1	45°		45°		-
α	0°	8°	0°	8°	-

* All specs and applications shown above subject to change without prior notice.

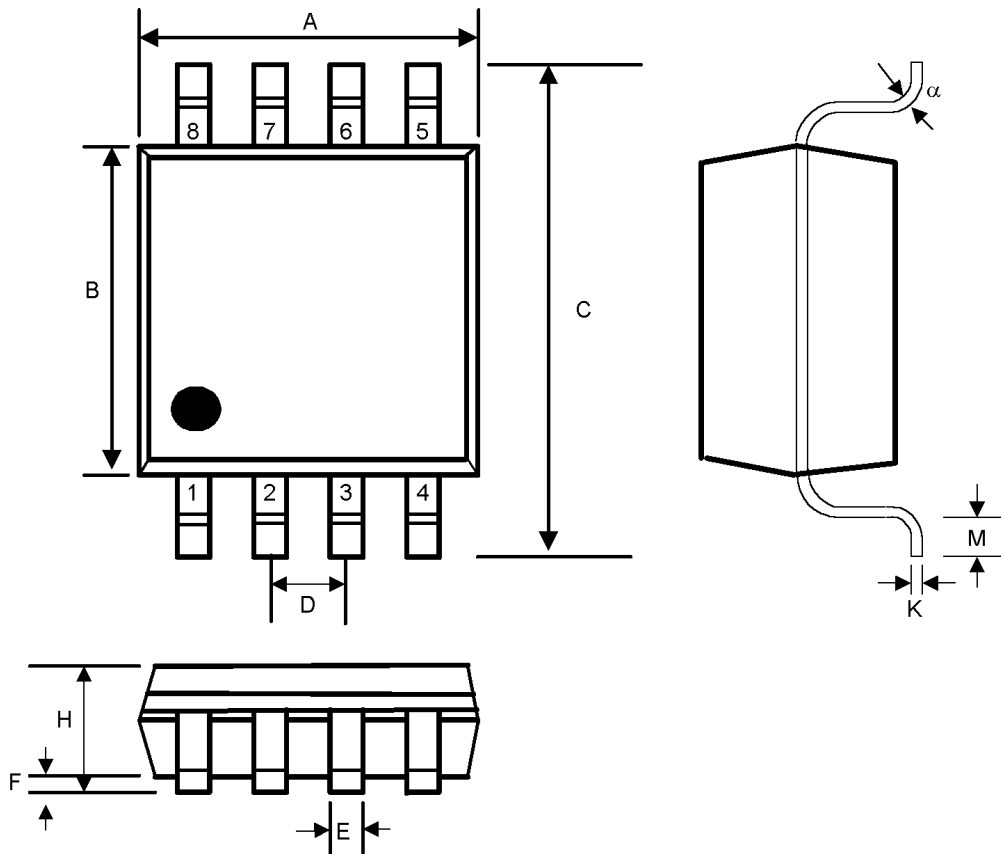
Switching Regulator Power Controller
Small Outline 8-pin TSSOP

SYMBOL	INCHES		MILLIMETERS		NOTES
	MIN	MAX	MIN	MAX	
A	0.114	0.122	2.90	3.10	-
B	0.169	0.177	4.30	4.50	-
C	0.244	0.260	6.20	6.60	-
D	0.026	BSC	0.65	BSC	-
E	0.010	0.012	0.25	0.30	-
F	0.002	0.006	0.05	0.15	-
H	0.041	0.047	1.05	1.20	-
K	0.005	BSC	0.127	BSC	-
M	0.020	0.028	0.50	0.70	-
α	0°	8°	0°	8°	-

* All specs and applications shown above subject to change without prior notice.

Switching Regulator Power Controller

Reflow Condition (IR/Convection or VPR Reflow)

Reference JEDEC Standard J-STD-020A

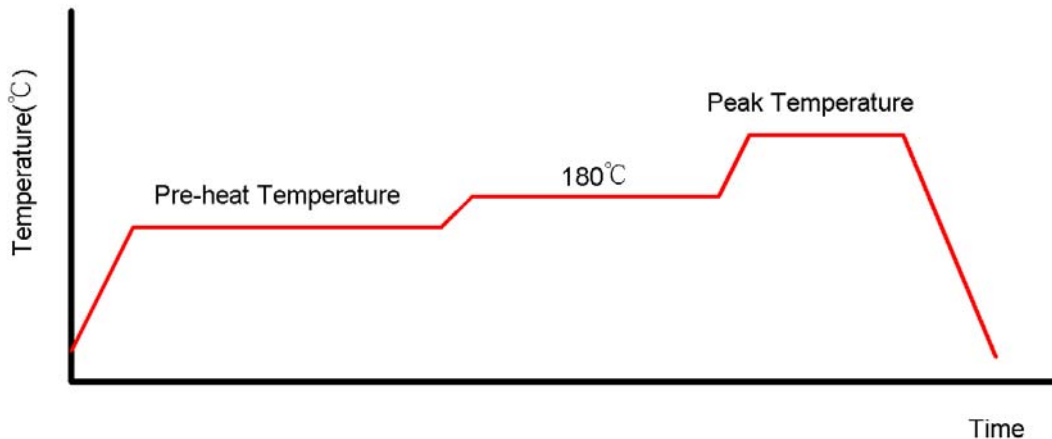

Classification Reflow Profiles

	Convection or IR/Convection	VPR
Average Heating Rate(180°C to peak)	5°C/second max.	10°C/second max.
Preheat Temperature(125±20°C)	120 seconds max.	
Temperature maintained above 180°C	10~150 seconds	
Time within 5°C of actual Peak Temperature	10~20 seconds	60 seconds
Peak Temperature Range(Note 1)	219~225°C or 235~240°C	219~225°C or 235~240°C
Cooling Rate	6°C /second max.	10°C/second max.
Time 25°C to Peak Temperature	6 minutes max.	

*1 The maximum peak temperatures for IR and VP reflow are depending on package dimensions.

Package Reflow Conditions

Pkg. Thickness ≥2.5mm and all bags	Pkg. Thickness <2.5mm and Pkg. Volume ≥350 mm ³	Pkg. Thickness <2.5mm and Pkg. Volume <350 mm ³
Convection 219~225°C		Convection 235~240°C
VPR 219~225°C		VPR 235~240°C
IR/Convection 219~225°C		IR/Convection 235~240°C

* All specs and applications shown above subject to change without prior notice.