



PRELIMINARY

CYM1846V33

512K x 32 3.3V Static RAM Module

Features

- High-density 3.3V 16-megabit SRAM module
- 32-bit Standard Footprint supports densities from 16K x 32 through 2M x 32
- High-speed SRAMs
 - Access time of 12 ns
- Low active power
 - 1.650W (max.) at 12 ns
- 72 pins
- Available in ZIP, SIMM format

Functional Description

The CYM1846V33 is a high-performance 3.3V 16-megabit static RAM module organized as 512K words by 32 bits. This

module is constructed from four 512K x 8 SRAMs in SOJ packages mounted on an epoxy laminate substrate. Four chip selects are used to independently enable the four bytes. Reading or writing can be executed on individual bytes or any combination of multiple bytes through proper use of selects.

The CYM1846V33 is designed for use with standard 72-pin SIMM sockets. The pinout is downward compatible with the 64-pin JEDEC ZIP/SIMM module family (CYM1821, CYM1831, CYM1836, and CYM1841). Thus, a single motherboard design can be used to accommodate memory depth ranging from 16K words (CYM1821) to 1,024K words (CYM1851). The CYM1846V33 is offered in vertical SIMM configuration and is available with either tin-lead or 10 micro-inches of gold flash on the edge contacts.

Presence detect pins (PD₀–PD₃) are used to identify module memory density in applications where modules with alternate word depths can be interchanged.

Logic Block Diagram

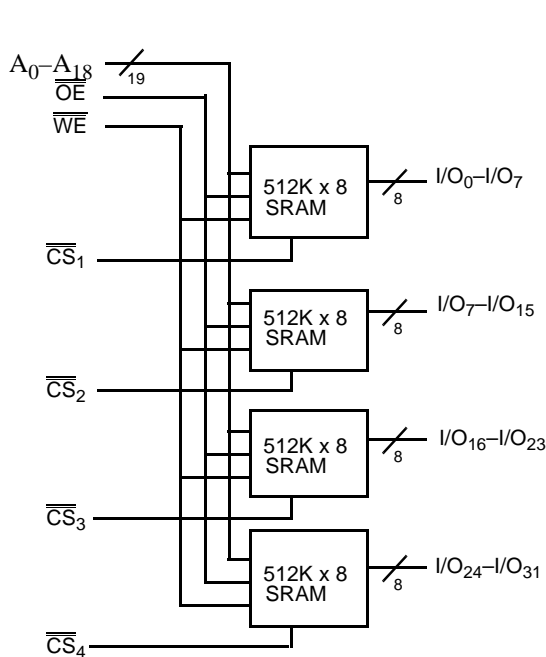

PD₀ - OPEN
 PD₁ - OPEN
 PD₂ - GND
 PD₃ - OPEN

Pin Configuration

ZIP/SIMM
 Top View

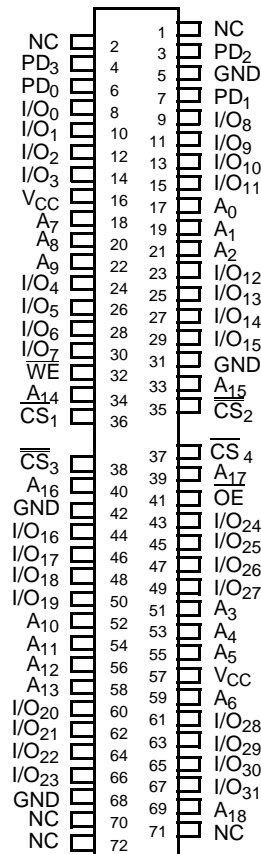

Selection Guide

	1846V33-12	1846V33-15	1846V33-20	1846V33-25	1846V33-35
Maximum Access Time (ns)	12	15	20	25	35
Maximum Operating Current (mA)	820	800	780	780	780
Maximum Standby Current (mA)	120	120	120	120	120

Shaded area contains advance information.

Maximum Ratings ^[1]

(Above which the useful life may be impaired. For user guidelines, not tested.)

Storage Temperature -55°C to +125°C

Ambient Temperature with Power Applied..... -10°C to +85°C

Supply Voltage to Ground Potential..... -0.5V to +4.6V

DC Voltage Applied to Outputs in High Z State -0.5V to +V_{CC}

DC Input Voltage -0.5V to +4.6V

Operating Range

Range	Ambient Temperature	V _{CC}
Commercial	0°C to +70°C	3.3V + 10% / -5%

Electrical Characteristics Over the Operating Range

Parameter	Description	Test Conditions	Min.	Max.	Unit
V _{OH}	Output HIGH Voltage	V _{CC} = Min., I _{OH} = -4.0 mA	2.4		V
V _{OL}	Output LOW Voltage	V _{CC} = Min., I _{OL} = 4.0 mA		0.4	V
V _{IH}	Input HIGH Voltage		2.0	V _{CC} + 0.3	V
V _{IL}	Input LOW Voltage		-0.3	0.8	V
I _{IX}	Input Load Current	GND ≤ V _I ≤ V _{CC}	-10	+10	μA
I _{OZ}	Output Leakage Current	GND ≤ V _O ≤ V _{CC} , Output Disabled	-10	+10	μA
I _{CC}	V _{CC} Operating Supply Current	V _{CC} = Max., I _{OUT} = 0 mA, CS _N ≤ V _{IL} , F = F _{MAX}	-12	820	mA
			-15	800	mA
			-20, -25, -35	780	mA
I _{SB1}	Automatic CS Power-Down Current ^[2]	Max. V _{CC} , CS ≥ V _{IH} , Min. Duty Cycle = 100%	-12	180	mA
			-15	160	mA
			-20, -25, -35	140	mA
I _{SB2}	Automatic CS Power-Down Current ^[2]	Max. V _{CC} , CS ≥ V _{CC} - 0.2V, V _{IN} ≥ V _{CC} - 0.2V, or V _{IN} ≤ 0.2V		120	mA

Shaded area contains advance information.

Capacitance ^[3]

Parameter	Description	Test Conditions	Max.	Unit
C _{INA}	Input Capacitance (WE, OE, A ₀₋₁₈)	T _A = 25°C, f = 1 MHz, V _{CC} = 5.0V	32	pF
C _{INB}	Input Capacitance (CS)		8	pF
C _{OUT}	Output Capacitance		8	pF

Notes:

1. If device is operated at these settings, long term reliability will be affected.
2. A pull-up resistor to V_{CC} on the CS input is required to keep the device deselected during V_{CC} power-up, otherwise I_{SB} will exceed values given.
3. Tested on a sample basis.

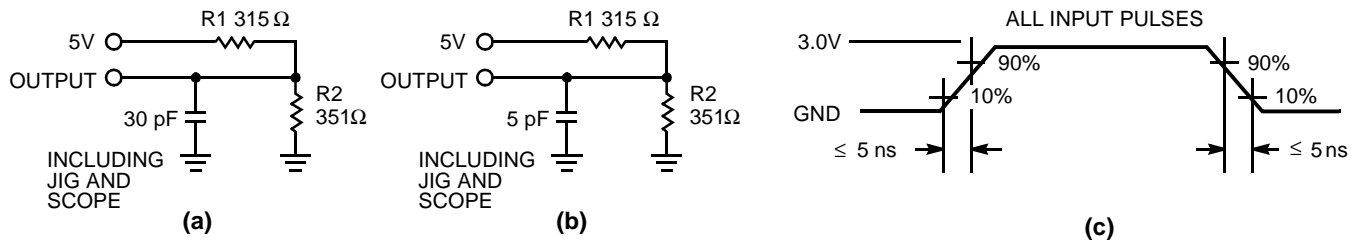
AC Test Loads and Waveforms

Equivalent to: THÉVENIN EQUIVALENT

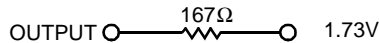
Switching Characteristics Over the Operating Range^[4]

Parameter	Description	1846V33-12		1846V33-15		Unit
		Min.	Max.	Min.	Max.	
READ CYCLE						
t_{RC}	Read Cycle Time	12		15		ns
t_{AA}	Address to Data Valid		12		15	ns
t_{OHA}	Data Hold from Address Change	3		3		ns
t_{ACS}	\overline{CS} LOW to Data Valid		12		15	ns
t_{DOE}	\overline{OE} LOW to Data Valid		7		8	ns
t_{LZOE}	\overline{OE} LOW to Low Z	0		0		ns
t_{HZOE}	\overline{OE} HIGH to High Z		7		8	ns
t_{LZCS}	\overline{CS} LOW to Low Z ^[5]	3		3		ns
t_{HZCS}	\overline{CS} HIGH to High Z ^[5, 6]		7		8	ns
t_{PD}	\overline{CS} HIGH to Power-Down		12		15	ns
WRITE CYCLE^[7]						
t_{WC}	Write Cycle Time	12		15		ns
t_{SCS}	\overline{CS} LOW to Write End	9		10		ns
t_{AW}	Address Set-Up to Write End	9		10		ns
t_{HA}	Address Hold from Write End	0		0		ns
t_{SA}	Address Set-Up to Write Start	1		1		ns
t_{PWE}	\overline{WE} Pulse Width	10		12		ns
t_{SD}	Data Set-Up to Write End	7		8		ns
t_{HD}	Data Hold from Write End	1		1		ns
t_{LZWE}	\overline{WE} HIGH to Low Z	3		3		ns
t_{HZWE}	\overline{WE} LOW to High Z ^[6]	0	7	0	8	ns

Shaded area contains advance information.

Notes:

- Test conditions assume signal transition times of 5 ns or less, timing reference levels of 1.5V, input pulse levels of 0 to 3.0V, and output loading of the specified I_{OL}/I_{OH} and 30-pF load capacitance.
- At any given temperature and voltage condition, t_{HZCS} is less than t_{LZCS} for any given device. These parameters are guaranteed and not 100% tested.
- t_{HZCS} and t_{HZWE} are specified with $C_L = 5$ pF as in part (b) of AC Test Loads and Waveforms. Transition is measured ± 500 mV from steady-state voltage.
- The internal write time of the memory is defined by the overlap of \overline{CS} LOW and \overline{WE} LOW. Both signals must be LOW to initiate a write and either signal can terminate a write by going HIGH. The data input set-up and hold timing should be referenced to the rising edge of the signal that terminates the write.

Switching Characteristics Over the Operating Range^[4] (continued)

Parameter	Description	1846V33-20		1846V33-25		1846V33-35		Unit
		Min.	Max.	Min.	Max.	Min.	Max.	
READ CYCLE								
t_{RC}	Read Cycle Time	20		25		35		ns
t_{AA}	Address to Data Valid		20		25		35	ns
t_{OHA}	Data Hold from Address Change	3		3		3		ns
t_{ACS}	\overline{CS} LOW to Data Valid		20		25		35	ns
t_{DOE}	\overline{OE} LOW to Data Valid		12		15		18	ns
t_{LZOE}	\overline{OE} LOW to Low Z	0		0		0		ns
t_{HZOE}	\overline{OE} HIGH to High Z		10		12		15	ns
t_{LZCS}	\overline{CS} LOW to Low Z ^[5]	3		3		3		ns
t_{HZCS}	\overline{CS} HIGH to High Z ^[5, 6]		10		12		15	ns
t_{PD}	\overline{CS} HIGH to Power-Down		20		25		35	ns
WRITE CYCLE^[7]								
t_{WC}	Write Cycle Time	20		25		35		ns
t_{SCS}	\overline{CS} LOW to Write End	17		20		30		ns
t_{AW}	Address Set-Up to Write End	17		20		30		ns
t_{HA}	Address Hold from Write End	3		3		3		ns
t_{SA}	Address Set-Up to Write Start	2		2		2		ns
t_{PWE}	\overline{WE} Pulse Width	15		20		30		ns
t_{SD}	Data Set-Up to Write End	12		15		20		ns
t_{HD}	Data Hold from Write End	2		2		2		ns
t_{LZWE}	\overline{WE} HIGH to Low Z	3		3		3		ns
t_{HZWE}	\overline{WE} LOW to High Z ^[6]	0	12	0	12	0	15	ns

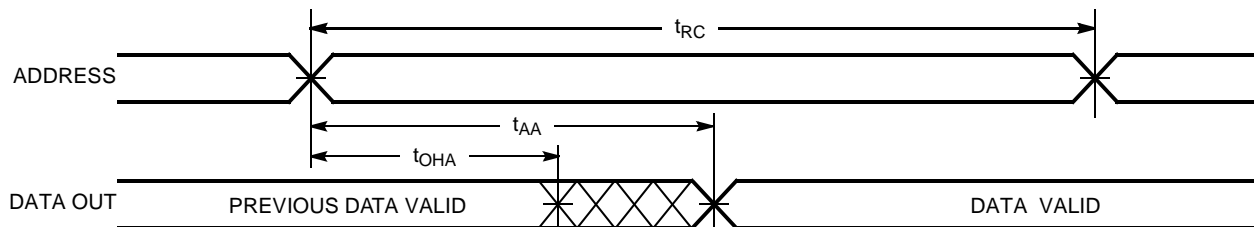
Switching Waveforms
Read Cycle No. 1^[8, 9]

Notes:

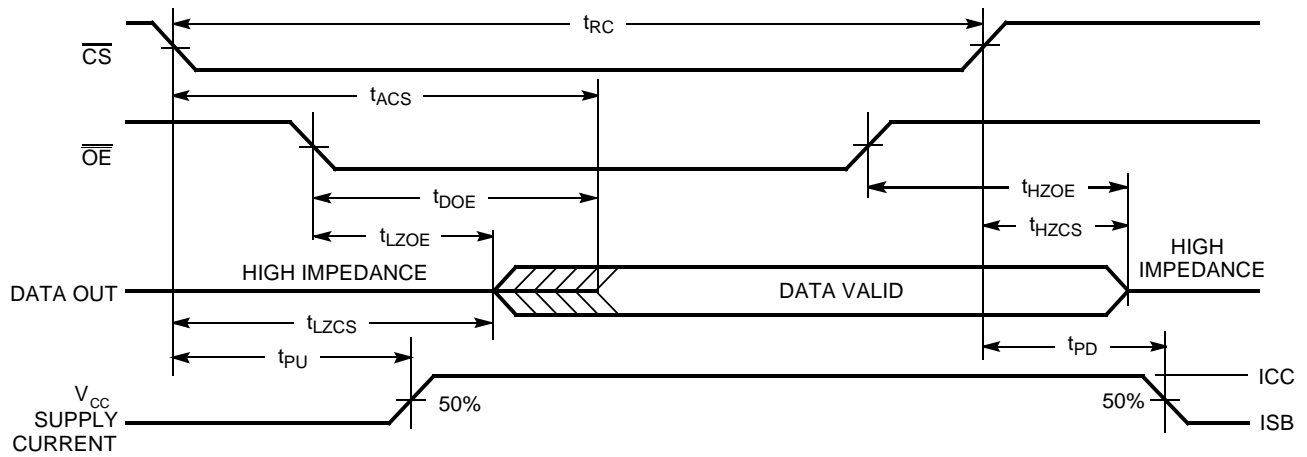
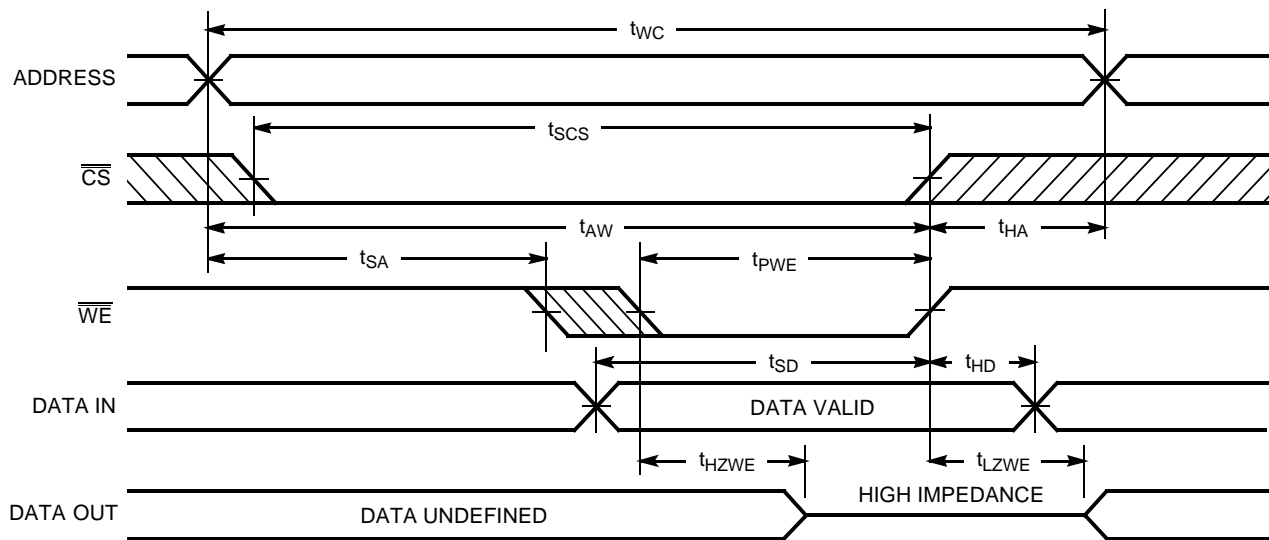
8. \overline{WE} is HIGH for read cycle.
9. Device is continuously selected, $\overline{CS} = V_{IL}$, and $\overline{OE} = V_{IL}$.

Switching Waveforms (continued)
Read Cycle No. 2 [8,10]

Write Cycle No. 1 (WE Controlled) [7]

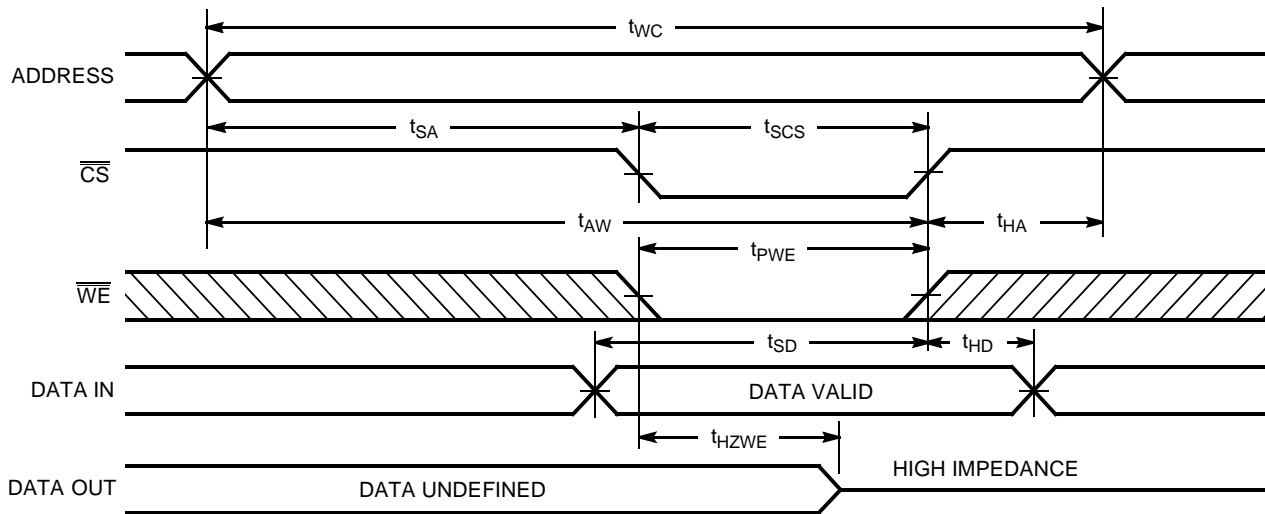
Note:

10. Address valid prior to or coincident with \overline{CS} transition LOW.

Switching Waveforms (continued)

Write Cycle No. 2 (CS Controlled) ^[7,11]

Truth Table

CS	WE	OE	Inputs/Output	Mode
H	X	X	High Z	Deselect/Power-Down
L	H	L	Data Out	Read
L	L	X	Data In	Write
L	H	H	High Z	Deselect

Ordering Information

Speed (ns)	Ordering Code	Package Type	Package Type	Operating Range
12	CYM1846V33PM-12C	PM21	72-Pin Plastic SIMM Module	Commercial
	CYM1846V33P8-12C	PM21	72-Pin Plastic SIMM Module (gold contacts)	
	CYM1846V33PZ-12C	PZ11	72-Pin Plastic ZIP Module	
15	CYM1846V33PM-15C	PM21	72-Pin Plastic SIMM Module	
	CYM1846V33P8-15C	PM11	72-Pin Plastic SIMM Module (gold contacts)	
	CYM1846V33PZ-15C	PZ11	72-Pin Plastic ZIP Module	
20	CYM1846V33PM-20C	PM21	72-Pin Plastic SIMM Module	
	CYM1846V33P8-20C	PM21	72-Pin Plastic SIMM Module (gold contacts)	
	CYM1846V33PZ-20C	PZ11	72-Pin Plastic ZIP Module	
25	CYM1846V33PM-25C	PM21	72-Pin Plastic SIMM Module	
	CYM1846V33P8-25C	PM21	72-Pin Plastic SIMM Module (gold contacts)	
	CYM1846V33PZ-25C	PZ11	72-Pin Plastic ZIP Module	

Shaded area contains advance information.

Note:

11. If CS goes HIGH simultaneously with WE HIGH, the output remains in a high-impedance state.

Ordering Information (continued)

Speed (ns)	Ordering Code	Package Type	Package Type	Operating Range
35	CYM1846V33PM-35C	PM21	72-Pin Plastic SIMM Module	Commercial
	CYM1846V33P8-35C	PM21	72-Pin Plastic SIMM Module (gold contacts)	
	CYM1846V33PZ-35C	PZ11	72-Pin Plastic ZIP Module	

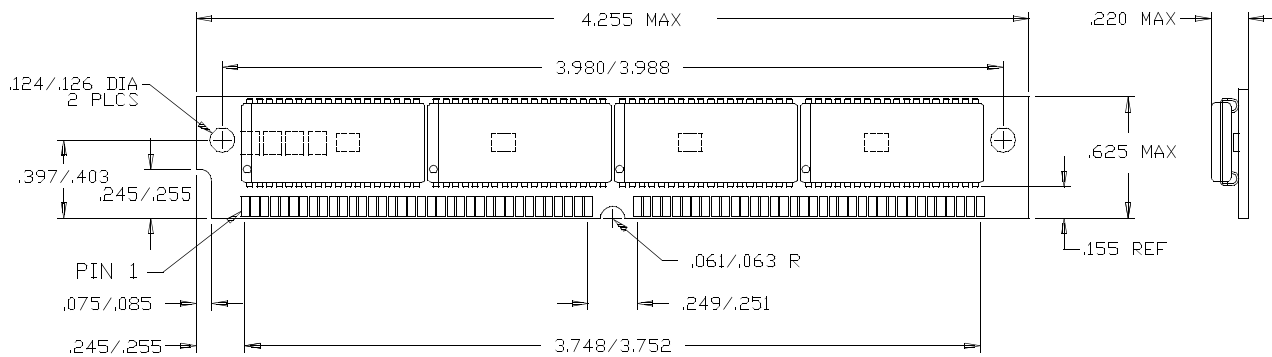
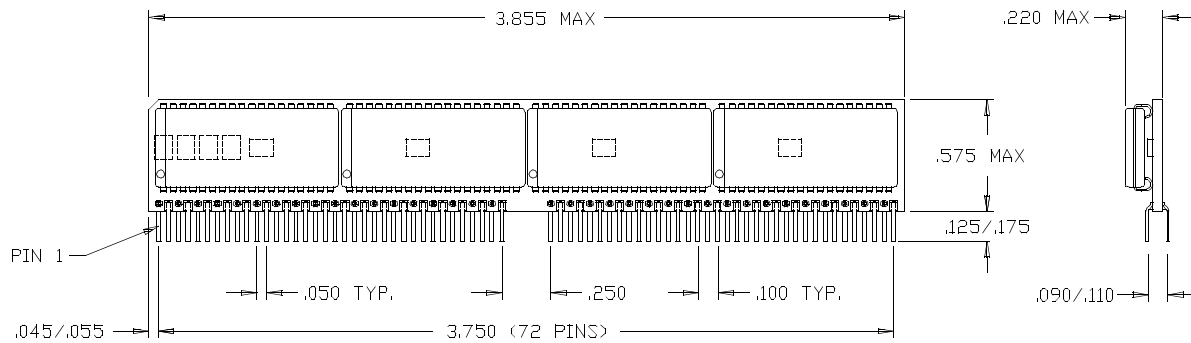
Package Diagrams
72-Pin Plastic SIMM Module PM21

72-Pin Plastic ZIP Module PZ11



Document Title: CYM1846V33 512K x 32 3.3V Static RAM Module Document Number: 38-05275				
REV.	ECN NO.	Issue Date	Orig. of Change	Description of Change
**	114176	3/19/02	DSG	Change from Spec number: 38-M-00089 to 38-05275