

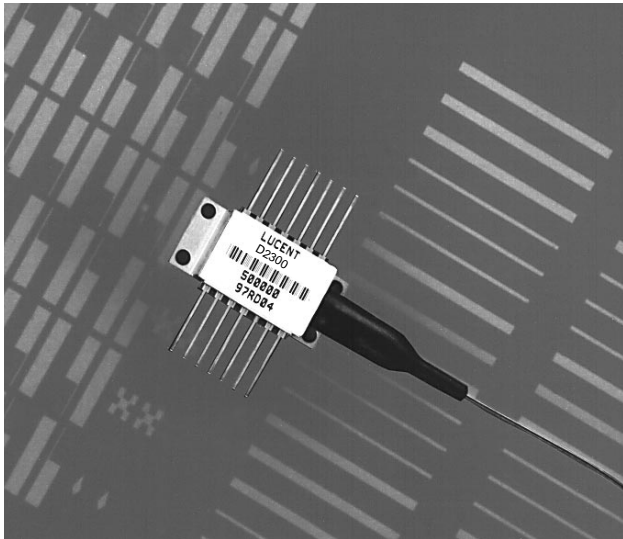

1.3 μm D2300-Type Laser Isolated DFB Laser Module



The 1.3 μm D2300-Type Laser Module is offered in a 14-pin, hermetic, butterfly package.

Features

- Integrated optical isolator
- SONET/SDH compatible up to OC-48/STM-16
- High-performance, distributed-feedback (DFB) laser
- High optical power available
- Industry-standard, 14-pin butterfly package
- Characterized at 2.488 Gbits/s (NRZ)
- Wide operating case temperature range:
–40 °C to +80 °C
- InGaAs, PIN photodetector back-facet monitor
- Low threshold current
- High reliability
- Qualified to meet the intent of *Telcordia Technologies** 468

* *Telcordia Technologies* is a trademark of Bell Communications Research, Inc.

Applications

- Telecommunications:
 - SONET/SDH
 - Long reach
 - Interexchange
- Digital video

Description

The D2300-Type Digital Isolated DFB Laser Module contains an internally cooled, InGaAsP, distributed-feedback (DFB) laser designed for 1.3 μm applications. The laser is designed to be used in OC-12/STM-4 (622 Mbits/s) and OC-48/STM-16 (2.488 Gbits/s) for long-reach and extended-reach applications.

The device is available with an average output power of 0 dBm (3 dBm peak), which meets the SONET/SDH standard.

Controlled Feedback

The module contains an internal optical isolator that suppresses optical feedback in laser-based, fiber-optic systems. Light reflected back to the laser is attenuated a minimum of 30 dB.

Controlled Temperature

An integral thermoelectric cooler (TEC) provides stable thermal characteristics. The TEC allows for heating and cooling of the laser chip to maintain a temperature of 25 $^{\circ}\text{C}$ for case temperatures from -40°C to $+80^{\circ}\text{C}$. The laser temperature is monitored by the internal thermistor, which can be used with external circuitry to control the laser chip temperature.

Controlled Power

An internal, InGaAs, PIN photodiode functions as the back-facet monitor. The photodiode monitors emission from the rear facet of the laser and, when used in conjunction with control circuitry, can control optical power launched into the fiber. Normally, this configuration is used in a feedback arrangement to maintain the average laser output power.

Standard Package

The laser module is fabricated in a 14-pin, hermetic, metal/ceramic butterfly package. The package also incorporates a bias tee that separates the dc-bias path from the RF input. The RF input has a nominal 25 Ω impedance. The laser module is equipped with a single-mode fiber. The pigtail has an 8 μm core and 125 μm cladding with a 900 μm tight buffer coating.

Lucent Technologies Microelectronics Group optoelectronic components are qualified to rigorous internal standards that are consistent with *Telcordia Technologies* TR-NWT-000468. All design and manufacturing operations are ISO* 9001 certified. The module is fully qualified for central office applications.

* ISO is a registered trademark of The International Organization for Standardization.

Pin Information

Pin	Name
1	Thermistor
2	Thermistor
3	Laser dc Bias (cathode) (-)
4	Back-facet Monitor Anode (-)
5	Back-facet Monitor Cathode (+)
6	Thermoelectric Cooler (+)*
7	Thermoelectric Cooler (-)*
8	Case Ground
9	Case Ground
10	Case Ground
11	Laser Anode [†] (+)
12	RF Laser Input Cathode (-)
13	Laser Anode [†] (+)
14	Case Ground

* A positive current through the thermoelectric heat pump cools the laser.

† Both leads should be grounded for optimum performance.

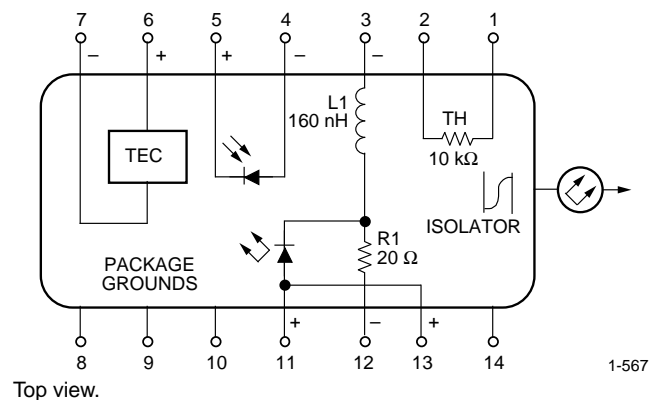

Figure 1. Circuit Schematic

Absolute Maximum Ratings

Stresses in excess of the absolute maximum ratings can cause permanent damage to the device. These are absolute stress ratings only. Functional operation of the device is not implied at these or any other conditions in excess of those given in the performance characteristics of the data sheet. Exposure to absolute maximum ratings for extended periods can adversely affect device reliability.

Parameter	Symbol	Min	Max	Unit
Laser Reverse Voltage	VRLMAX	—	2	V
dc Forward Current	IFLMAX	—	150	mA
Operating Case Temperature Range	T _C	-40	80	°C
Storage Case Temperature Range*	T _{stg}	-40	85	°C
Photodiode Reverse Voltage	VRPDMAX	—	10	V
Photodiode Forward Current	IFPDMAX	—	1	mA

* Does not apply to shipping container.

Handling Precautions

Power Sequencing

To avoid the possibility of damage to the laser module from power supply switching transients, follow this turn-on sequence:

1. All ground connections
2. Most negative supply
3. Most positive supply
4. All remaining connections

Reverse the order for the proper turn-off sequence.

Electrostatic Discharge

CAUTION: This device is susceptible to damage as a result of electrostatic discharge. Take proper precautions during both handling and testing. Follow guidelines such as JEDEC Publication No. 108-A (Dec. 1988).

Lucent employs a human-body model (HBM) for ESD-susceptibility testing and protection-design evaluation. ESD voltage thresholds are dependent on the critical parameters used to define the model. A standard HBM (resistance = 1.5 kΩ, capacitance = 100 pF) is widely used and, therefore, can be used for comparison purposes. The HBM ESD threshold presented here was obtained using these circuit parameters:

Parameter	Value	Unit
Human-body Model	>400	V

Lucent Technologies Inc.

Mounting Instructions

The minimum fiber bend radius is 1.18 in. (30 mm).

To avoid degradation in performance, mount the module on the board as follows:

1. Place the bottom flange of the module on a flat heat sink at least 0.5 in. x 1.180 in. (12.7 mm x 30 mm) in size. The surface finish of the heat sink should be better than 32 μin. (0.8 μm), and the surface flatness must be better than 0.001 in. (25.4 μm). Using thermal conductive grease is optional; however, thermal performance can be improved by up to 5% if conductive grease is applied between the bottom flange and the heat sink.
2. Mount four #2-56 screws with Fillister heads (M2-3 mm) at the four screw-hole locations (see Outline Diagram). The Fillister head diameter must not exceed 0.140 in. (3.55 mm). Do not apply more than 1 in.-lb. of torque to the screws.

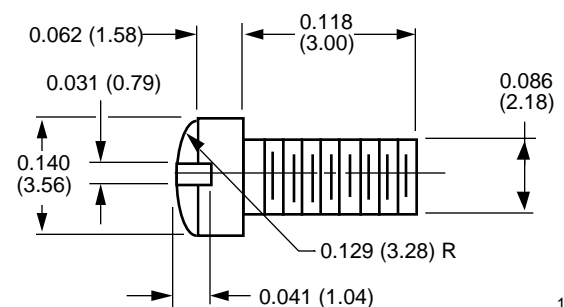

Note: Dimensions are in inches and (millimeters).

1-532

Figure 2. Fillister Head Screw

Characteristics

Minimum and maximum values are testing requirements. Typical values are characteristics of the device and are the result of engineering evaluations. Typical values are for information purposes only and are not part of the testing requirements.

Table 1. Electrical Characteristics (at 25 °C Laser Temperature)

Parameter	Symbol	Test Conditions	Min	Typ	Max	Unit
Laser Forward Voltage	V _{LF}	LF = 2 mW (CW)	—	1.3	1.8	V
Slope Efficiency	η	LF = 2 mW (CW)	0.025	0.06	—	mW/mA
Threshold Current	I _{TH}	—	—	15	50	mA
Monitor Reverse-bias Voltage*	V _{RMON}	—	3	5	10	V
Monitor Current	I _{RMON}	P _O = 1 mW (CW)	0.1	1.0	2.0	mA
Monitor Dark Current	I _D	I _F = 0, V _{RMON} = 5 V	—	0.01	0.1	μA
Input Impedance	Z _{IN}	—	—	25	—	Ω
Thermistor Current	I _{TC}	—	10	—	100	μA
Resistance Ratio [†]	—	—	8.6	—	9.6	—
Thermistor Resistance	R _{TH}	T _L = 25 °C	9.5	—	10.5	k Ω
TEC Current	I _{TEC}	T _L = 25 °C, T _C = 70 °C	—	—	1.0	A
TEC Voltage	V _{TEC}	T _L = 25 °C, T _C = 70 °C	—	—	2.0	V
TEC Capacity	ΔT	T _C = 80 °C	55	—	—	°C

* Standard operating condition is 5.0 V reverse bias.

[†] Ratio of thermistor resistance at 0 °C to thermistor resistance at 50 °C.

Table 2. Optical Characteristics (at 25 °C Laser Temperature)

Parameter	Symbol	Test Conditions	Min	Typ	Max	Unit
Peak Optical Output Power	P _{PEAK}	—	2.0	—	—	mW
Center Wavelength	λ_C	—	1290	1310	1330	nm
Spectral Width: Full Width at -3 dB Full Width at -20 dB	$\Delta\lambda$	Modulated at 2.5 Gbits/s at rated power	— —	0.20 0.8	0.30 1.0	nm nm
Side-mode Suppression Ratio	SMSR	Modulated at 2.5 Gbits/s	30	—	—	dB
Optical Isolation	—	0 °C to 65 °C	30	—	—	dB

Outline Diagram

Dimensions are in inches and (millimeters). Tolerances are ±0.005 in. (±0.127 mm).

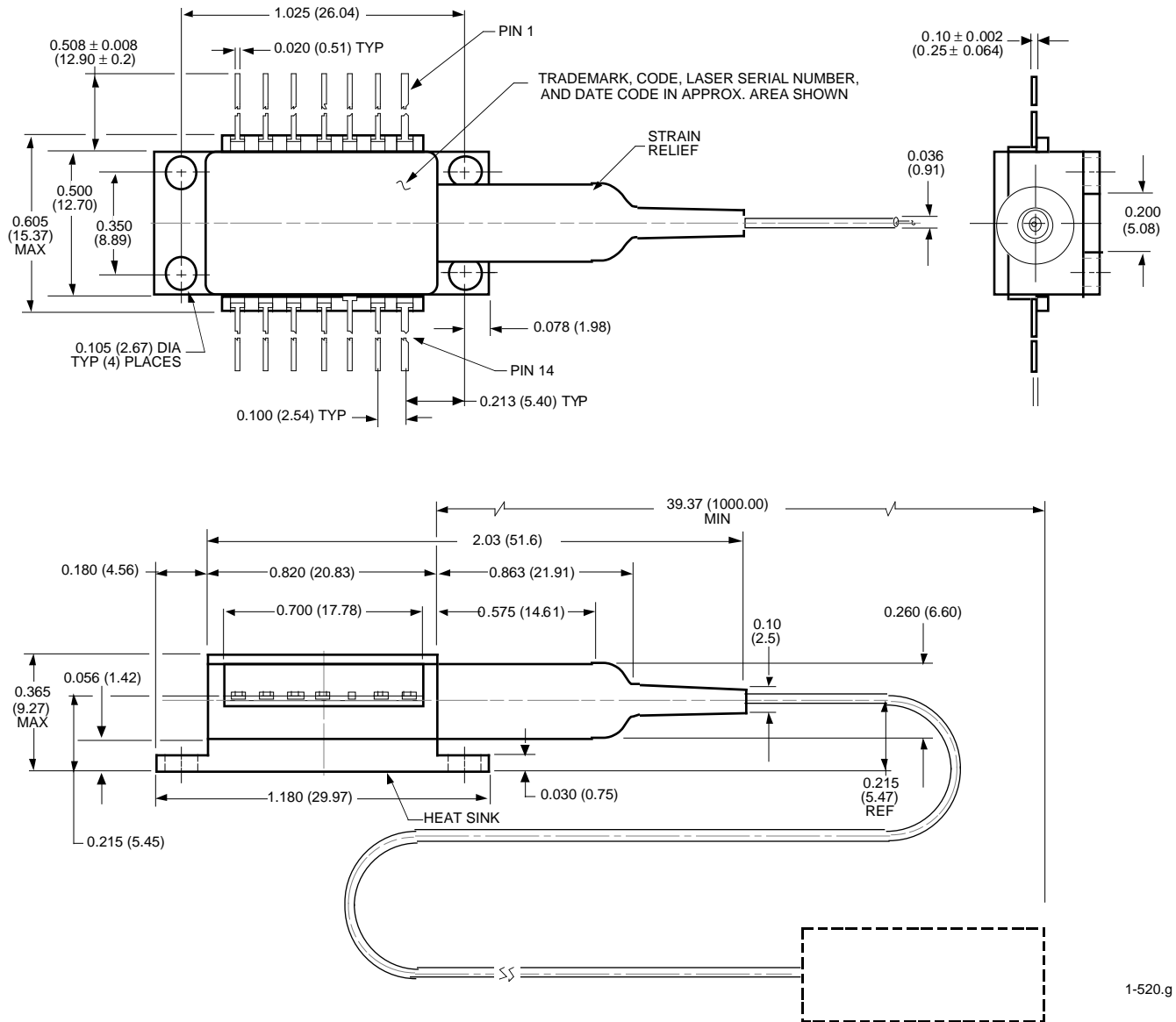

Class IIIb Laser Product

FDA/CDRH Class IIIb laser product. All versions are Class IIIb laser products per CDRH, 21 CFR 1040 Laser Safety requirements. All versions are Class IIIb laser products per *IEC** 60825-1:1993. The device has been certified with the FDA under accession number 8720010.

This product complies with 21 CFR 1040.10 and 1040.11.

8 μm /125 μm single-mode fiber pigtail with 900 μm tight buffer jacket and connector

Wavelength = 1.3 μm

Maximum power = 10 mW

Because of size constraints, labeling is not affixed to the module but is contained in the shipping carton.

Product is not shipped with power supply.

Caution: Use of controls, adjustments, and procedures other than those specified herein may result in hazardous laser radiation exposure.

* *IEC* is a registered trademark of The International Electrotechnical Commission.

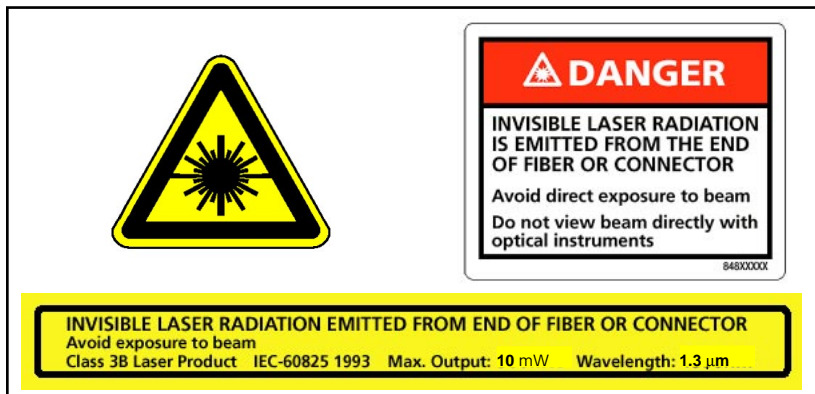

Ordering Information

Table 3. Ordering Information

Device Code	Connector	Comcode
D2304G	FC-PC*	107912990

* Other connector options are available.

For additional information, contact your Microelectronics Group Account Manager or the following:

INTERNET: <http://www.lucent.com/micro>, or for Optoelectronics information, <http://www.lucent.com/micro/opto>

E-MAIL: docmaster@micro.lucent.com

N. AMERICA: Microelectronics Group, Lucent Technologies Inc., 555 Union Boulevard, Room 30L-15P-BA, Allentown, PA 18103
1-800-372-2447, FAX 610-712-4106 (In CANADA: **1-800-553-2448**, FAX 610-712-4106)

ASIA PACIFIC: Microelectronics Group, Lucent Technologies Singapore Pte. Ltd., 77 Science Park Drive, #03-18 Cintech III, Singapore 118256
Tel. (65) 778 8833, FAX (65) 777 7495

CHINA: Microelectronics Group, Lucent Technologies (China) Co., Ltd., A-F2, 23/F, Zao Fong Universe Building, 1800 Zhong Shan Xi Road, Shanghai 200233 P. R. China **Tel. (86) 21 6440 0468, ext. 316**, FAX (86) 21 6440 0652

JAPAN: Microelectronics Group, Lucent Technologies Japan Ltd., 7-18, Higashi-Gotanda 2-chome, Shinagawa-ku, Tokyo 141, Japan
Tel. (81) 3 5421 1600, FAX (81) 3 5421 1700

EUROPE: Data Requests: MICROELECTRONICS GROUP DATALINE: **Tel. (44) 7000 582 368**, FAX (44) 1189 328 148

Technical Inquiries: OPTOELECTRONICS MARKETING: **(44) 1344 865 900** (Ascot UK)

Lucent Technologies Inc. reserves the right to make changes to the product(s) or information contained herein without notice. No liability is assumed as a result of their use or application. No rights under any patent accompany the sale of any such product(s) or information.

