

MOS INTEGRATED CIRCUIT

μ PD780016Y, 780018Y

8-BIT SINGLE-CHIP MICROCONTROLLER

DESCRIPTION

The μ PD780016Y and 780018Y are members of the μ PD780018Y subseries of the 78K/0 series microcontrollers.

Besides a high-speed, high-performance CPU, these microcontrollers have on-chip ROM, RAM, I/O ports, timer, serial interface, real-time output port, interrupt control, and various other peripheral hardware.

The μ PD78P0018Y devices including a one-time PROM version and an EPROM version, both of which can operate in the same power supply voltage range as a mask ROM version, and various development tools are available.

The details of the functions are described in the following user's manuals. Be sure to read it before starting design.

μ PD780018,780018Y Subseries User's Manual: U11754E

78K/0 Series User's Manual – Instructions : IEU-1372

FEATURES

- Internal high capacity ROM and RAM

Part Number	Item	Program Memory (ROM)	Data Memory			Package
			Internal High-Speed RAM	Buffer RAM	Internal Extended RAM	
μ PD780016Y		48K bytes	1024 bytes	32 bytes	1024 bytes	100-pin plastic QFP (14 × 20 mm)
μ PD780018Y		60K bytes				

- External memory expansion space: 64K bytes
- Instruction execution time can be changed from high-speed (0.4 μ s) to ultra-low-speed (122 μ s)
- I/O ports: 88
- 8-bit resolution A/D converter: 8 channels
- Timer: 7 channels
- Serial interface: 3 channels
 - 3-wire serial I/O mode (with automatic data transmit/receive function): 1 channel
 - 3-wire serial I/O mode (with time division transfer function): 1 channel
 - I²C bus mode (supporting multi-task): 1 channel
- Supply voltage : $V_{DD} = 2.7$ to 5.5 V

APPLICATION FIELD

Cellular phones, cordless phones, AV equipment, etc.

The information contained in this document is being issued in advance of the production cycle for the device. The parameters for the device may change before final production or NEC Corporation, at its own discretion, may withdraw the device prior to its production.

ORDERING INFORMATION

Part Number	Package
μPD780016YGF-XXX-3BA	100-pin plastic QFP (14 × 20 mm)
μPD780018YGF-XXX-3BA	100-pin plastic QFP (14 × 20 mm)

Remark XXX indicates ROM code suffix.

78K/0 SERIES DEVELOPMENT

These products are a further development in the 78K/0 Series. The designations appearing inside the boxes are subseries names.

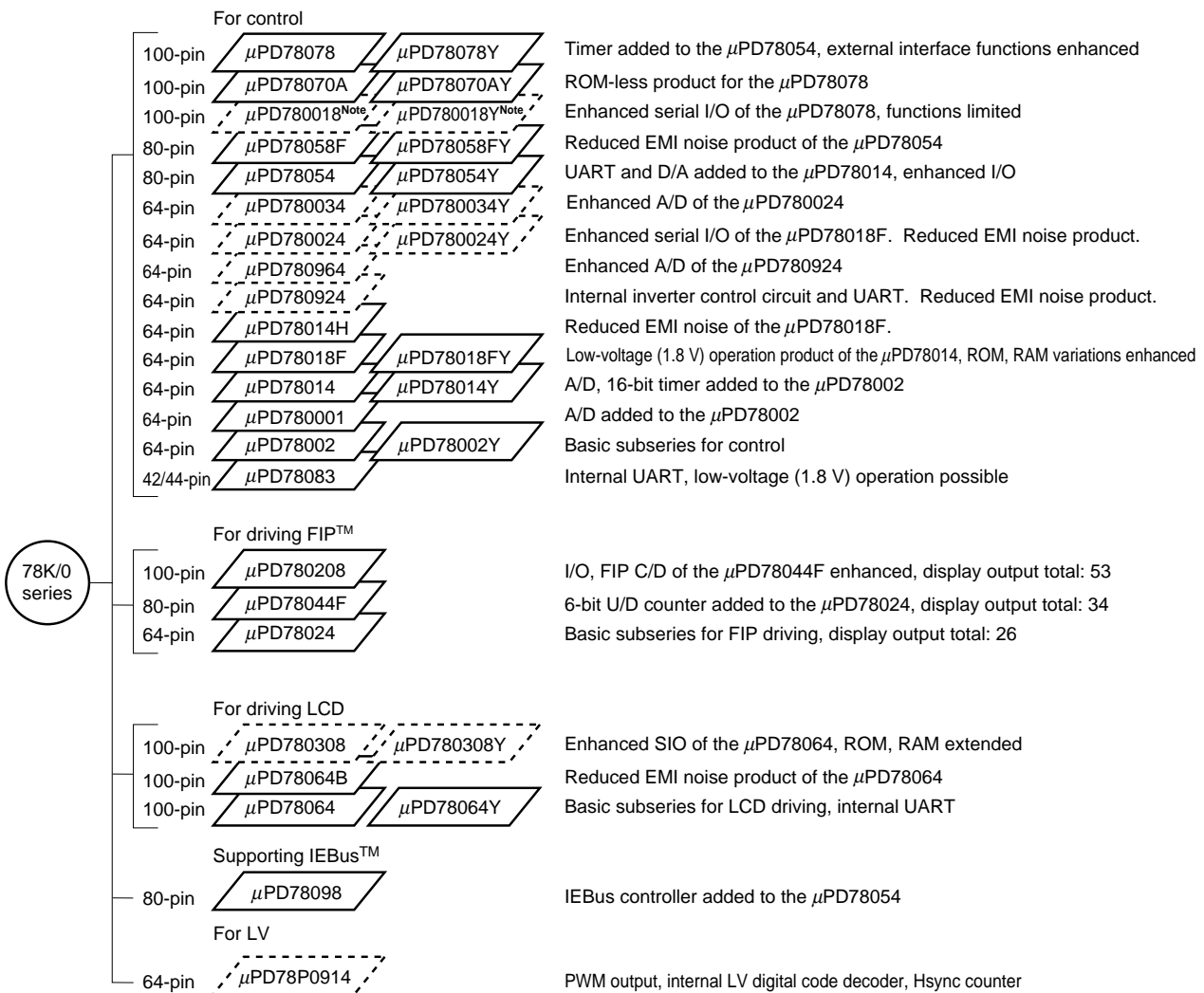
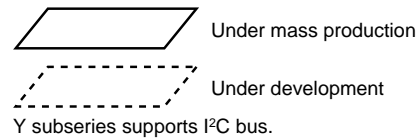

Note Under planning

The major functional differences among the subseries are shown below.

Function Subseries Name		ROM Capacity	Timer				8-bit A/D	10-bit A/D	8-bit D/A	Serial Interface	I/O	V _{DD} MIN. Value	External Expansion	
			8-bit	16-bit	Watch	WDT								
For Control	μPD78078	32 K-60 K	4ch	1ch	1ch	1ch	8ch	—	2ch	3ch (UART: 1ch)	88	1.8 V	○	
	μPD78070A	—								61	2.7 V			
	μPD780018	48 K-60 K	2ch	1ch	1ch	1ch	8ch	—	2ch	—	88	2.0 V		
	μPD78058F									3ch (UART: 1ch)	69			
	μPD78054	16 K-60 K	2ch	1ch	1ch	1ch	8ch	—	2ch	—	51	1.8 V		
	μPD780034	8 K-32 K								8ch	—	51		1.8 V
	μPD780024	8 K-32 K	3ch	Note	—	1ch	1ch	8ch	—	2ch (UART: 2ch)	—	47		2.7 V
	μPD780964										8ch	—		47
	μPD780924	8 K-32 K	2ch	1ch	1ch	1ch	8ch	—	2ch	2ch	53	1.8 V		
	μPD78014H									2ch	53	1.8 V		
	μPD78018F	8 K-60 K	2ch	1ch	1ch	1ch	8ch	—	2ch	—	39	2.7 V		
	μPD78014	8 K-32 K								1ch	—			39
	μPD780001	8 K	2ch	—	—	1ch	1ch	8ch	—	1ch	53	—		
	μPD780002	8 K-16 K								1ch	—	53		—
μPD780083	8 K	2ch	—	—	1ch	1ch	8ch	—	1ch (UART: 1ch)	33	1.8 V	—		
For FIP driving	μPD780208	32 K-60 K	2ch	1ch	1ch	1ch	8ch	—	—	2ch	74	2.7 V	—	
	μPD78044F	16 K-40 K									68			
	μPD78024	24 K-32 K									54			
For LCD driving	μPD780308	48 K-60 K	2ch	1ch	1ch	1ch	8ch	—	—	3ch (UART: 1ch)	57	1.8 V	—	
	μPD78064B	32 K								2ch (UART: 1ch)	57	2.0 V		
	μPD78064	16 K-32 K								2ch (UART: 1ch)	57	2.0 V		
For IEBus	μPD78098	32 K-60 K	2ch	1ch	1ch	1ch	8ch	—	2ch	3ch (UART: 1ch)	69	2.7 V	○	
For LV	μPD78P0914	32 K	6ch	—	—	1ch	8ch	—	—	2ch	54	4.5 V	○	

Note 10-bit timer: 1 channel

OVERVIEW OF FUNCTION

Item		Part Number	μPD780016Y	μPD780018Y
Internal memory	ROM		48K bytes	60K bytes
	Internal high-speed RAM		1024 bytes	
	Buffer RAM		32 bytes	
	Internal expansion RAM		1024 bytes	
Memory space			64K bytes	
General registers			8 bits × 32 registers (8 bits × 8 registers × 4 banks)	
Instruction cycle			On-chip instruction execution time selective function	
	When main system clock selected		0.4 μs/0.8 μs/1.6 μs/3.2 μs/6.4 μs (at 5.0 MHz)	
	When subsystem clock selected		122 μs (at 32.768 kHz)	
Instruction set			<ul style="list-style-type: none"> • 16-bit operation • Multiplication/division (8 bits × 8 bits, 16 bits ÷ 8 bits) • Bit manipulation (set, reset, test, boolean operation) • BCD adjustment, etc. 	
I/O ports			Total : 88 <ul style="list-style-type: none"> • CMOS input : 9 • CMOS I/O : 79 	
A/D converter			<ul style="list-style-type: none"> • 8-bit resolution × 8 channels 	
Serial interface			<ul style="list-style-type: none"> • 3-wire serial I/O mode (with automatic data transmit/receive function): 1 channel • 3-wire serial I/O mode (with time division transfer function) : 1 channel • I²C bus mode (supporting multi-task) : 1 channel 	
Timer			<ul style="list-style-type: none"> • 16-bit timer/event counter: 1 channel • 8-bit timer/event counter : 4 channels • Watch timer : 1 channel • Watchdog timer : 1 channel 	
Timer output			5 (14-bit PWM output × 1, 8-bit PWM output × 2)	
Clock output			39.1 kHz, 78.1 kHz, 156 kHz, 313 kHz, 625 kHz, 1.25 MHz, 2.5 MHz, 5.0 MHz (at main system clock of 5.0 MHz) 32.768 kHz (at subsystem clock of 32.768 kHz)	
Buzzer output			2.4 kHz, 4.9 kHz, 9.8 kHz (at main system clock: at 5.0 MHz)	
Vectored interrupt sources	Maskable		Internal : 12 External: 7	
	Non-maskable		Internal : 1	
	Software		1	
Test input			Internal : 1 External: 1	
Supply voltage			V _{DD} = 2.7 to 5.5 V	
Package			<ul style="list-style-type: none"> • 100-pin plastic QFP (14 × 20 mm) 	

CONTENTS

1. PIN CONFIGURATION (TOP VIEW) 6

2. BLOCK DIAGRAM 8

3. PIN FUNCTIONS 9

 3.1 Port Pins 9

 3.2 Non-port Pins 11

 3.3 Pin I/O Circuits and Recommended Connection of Unused Pins 13

4. MEMORY SPACE 16

5. PERIPHERAL HARDWARE FUNCTIONS 17

 5.1 Ports 17

 5.2 Clock Generator 18

 5.3 Timer/Event Counter 18

 5.4 Clock Output Control Circuit 22

 5.5 Buzzer Output Control Circuit 22

 5.6 A/D Converter 23

 5.7 Serial Interfaces 24

6. INTERRUPT FUNCTIONS AND TEST FUNCTIONS 26

 6.1 Interrupt Functions 26

 6.2 Test Functions 29

7. EXTERNAL DEVICE EXPANSION FUNCTIONS 30

8. STANDBY FUNCTION 30

9. RESET FUNCTION 31

10. INSTRUCTION SET 32

11. PACKAGE DRAWINGS 34

APPENDIX A. DEVELOPMENT TOOLS 35

APPENDIX B. RELATED DOCUMENTS 37

1. PIN CONFIGURATION (TOP VIEW)

- 100-pin plastic QFP (14 × 20 mm)
μPD780016YGF-XXX-3BA, 780018YGF-XXX-3BA

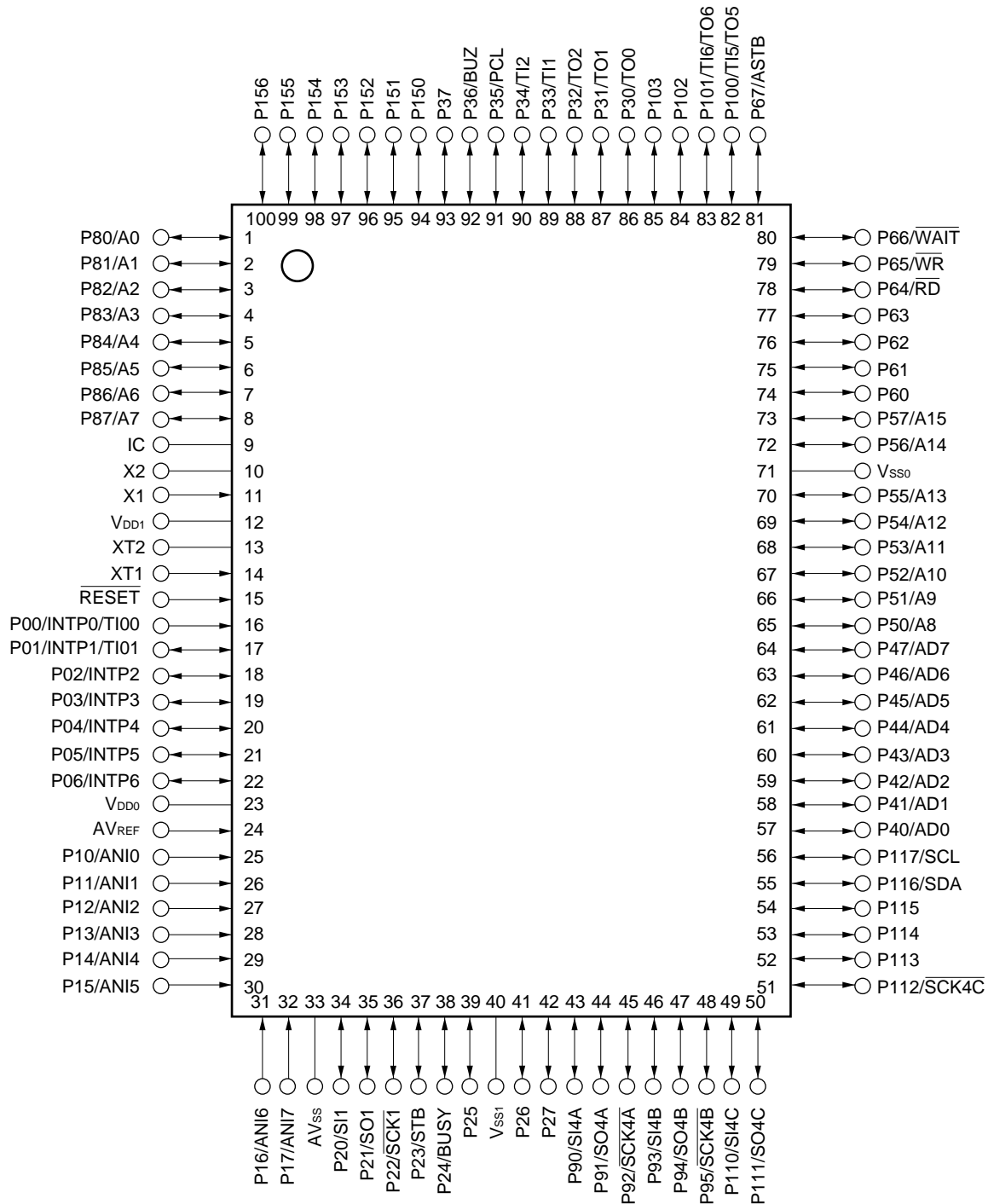

- Cautions**
1. Connect IC (internally connected) pin directly to V_{SS0}.
 2. AV_{SS} pin should be connected to V_{SS0}.

Remark When the circuit is used in an application where the noise generated from the inside of the microcontroller needs to be reduced, take countermeasures against noise such as supplying power to V_{DD0} and V_{DD1} separately and connecting V_{SS0} and V_{SS1} to the ground line separately.

A0-A15	: Address Bus	PCL	: Programmable Clock
AD0-AD7	: Address/Data Bus	RD	: Read Strobe
ANI0-ANI7	: Analog Input	RESET	: Reset
ASTB	: Address Strobe	SCK1	: Serial Clock
AVREF	: Analog Reference Voltage	SCK4A, SCK4B, SCK4C	: Serial Clock
AVss	: Analog Ground	SCL	: Serial Clock
BUSY	: Busy	SDA	: Serial Data
BUZ	: Buzzer Clock	SI1	: Serial Input
IC	: Internally Connected	SI4A, SI4B, SI4C	: Serial Input
INTP0-INTP6	: Interrupt from Peripherals	SO1	: Serial Output
P00-P06	: Port0	SO4A, SO4B, SO4C	: Serial Output
P10-P17	: Port1	STB	: Strobe
P20-P27	: Port2	TI00, TI01	: Timer Input
P30-P37	: Port3	TI1, TI2, TI5, TI6	: Timer Input
P40-P47	: Port4	TO0-TO2, TO5, TO6	: Timer Output
P50-P57	: Port5	VDD0, VDD1	: Power Supply
P60-P67	: Port6	VSS0, VSS1	: Ground
P80-P87	: Port8	WAIT	: Wait
P90-P96	: Port9	WR	: Write Strobe
P100-P103	: Port10	X1, X2	: Crystal (Main System Clock)
P110-P117	: Port11	XT, XT2	: Crystal (Subsystem Clock)
P150-P156	: Port15		

2. BLOCK DIAGRAM

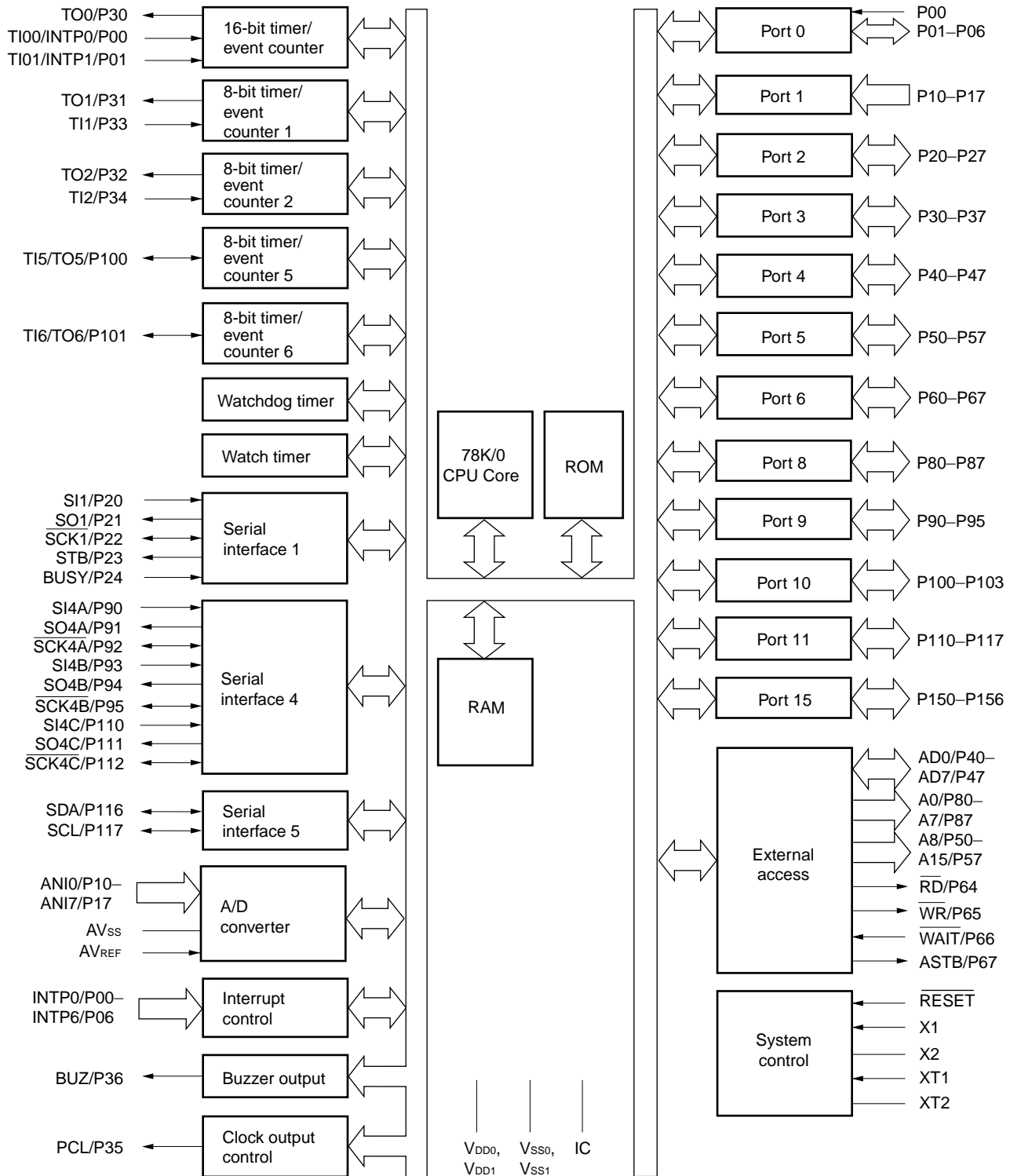

Remark The internal ROM capacity depends on the product.

3. PIN FUNCTIONS

3.1 Port Pins (1/2)

Pin Name	I/O	Function		After Reset	Alternate Function Pin
P00	Input	Port 0 7-bit I/O port	Input only	Input	INTP0/TI00
P01	Input/ output		Input/output can be specified bit-wise. When used as an input port, on-chip pull-up resistor can be used by software.	Input	INTP1/TI01
P02					INTP2
P03					INTP3
P04					INTP4
P05					INTP5
P06					INTP6
P10 to P17	Input	Port 1 8-bit input port On-chip pull-up resistor can be used by software. ^{Note}		Input	ANI0 to ANI7
P20	Input/ output	Port 2 8-bit input/output port Input/output can be specified bit-wise. When used as an input port, on-chip pull-up resistor can be used by software.	Input	SI1	
P21				SO1	
P22				SCK1	
P23				STB	
P24				BUSY	
P25-P27				—	
P30	Input/ output	Port 3 8-bit input/output port Input/output can be specified bit-wise. When used as an input port, on-chip pull-up resistor can be used by software.	Input	TO0	
P31				TO1	
P32				TO2	
P33				TI1	
P34				TI2	
P35				PCL	
P36				BUZ	
P37				—	
P40 to P47	Input/ output	Port 4 8-bit input/output port Input/output can be specified in 8-bit units. When used as an input port, on-chip pull-up resistor can be used by software. Test input flag (KRIF) is set to 1 by falling edge detection.		Input	AD0 to AD7

Note When using the P10/ANI0 to P17/ANI7 pins as the A/D converter analog input, on-chip pull-up resistor is automatically disconnected.

3.1 Port Pins (2/2)

Pin Name	I/O	Function	After Reset	Alternate Function Pin
P50 to P57	Input/output	Port 5 8-bit input/output port LED can be driven directly. Input/output can be specified bit-wise. When used as an input port, on-chip pull-up resistor can be used by software.	Input	A8 to A15
P60	Input/output	Port 6 8-bit input/ output port Input/output can be specified bit-wise. When used as an input port, on-chip pull-up resistor can be used by software.	Input	—
P61				—
P62				—
P63				—
P64				\overline{RD}
P65				\overline{WR}
P66				\overline{WAIT}
P67				ASTB
P80 to P87	Input/output	Port 8 8-bit input/output port Input/output can be specified bit-wise. When used as an input port, on-chip pull-up resistor can be used by software.	Input	A0 to A7
P90	Input/output	Port 9 6-bit input/output port Input/output can be specified bit-wise. When used as an input port, on-chip pull-up resistor can be used by software.	Input	SI4A
P91				SO4A
P92				$\overline{SCK4A}$
P93				SI4B
P94				SO4B
P95				$\overline{SCK4B}$
P100	Input/output	Port 10 4-bit input/output port Input/output can be specified bit-wise. When used as an input port, on-chip pull-up resistor can be used by software.	Input	TI5/TO5
P101				TI6/TO6
P102, P103				—
P110	Input/output	Port 11 8-bit input/output port Input/output can be specified bit-wise. When used as an input port, on-chip pull-up resistor can be used by software.	Input	SI4C
P111				SO4C
P112				$\overline{SCK4C}$
P113-P115				—
P116				SDA
P117				SCL
P150-P156	Input/output	Port 15 7-bit input/output port Input/output can be specified bit-wise. When used as an input port, on-chip pull-up resistor can be used by software.	Input	—

3.2 Non-port Pins (1/2)

Pin Name	I/O	Function	After Reset	Alternate Function Pin
INTP0	Input	External interrupt request input by which the active edge (rising edge, falling edge, or both rising and falling edges) can be specified.	Input	P00/TI00
INTP1				P01/TI01
INTP2				P02
INTP3				P03
INTP4				P04
INTP5				P05
INTP6				P06
SI1	Input	Serial interface serial data input.	Input	P20
SI4A				P90
SI4B				P93
SI4C				P110
SO1	Output	Serial interface serial data output.	Input	P21
SO4A				P91
SO4B				P94
SO4C				P111
SDA	Input/output	Input/output of serial data of serial interface.	Input	P116
SCK1	Input /output	Serial interface serial clock input/output.	Input	P22
SCK4A				P92
SCK4B				P95
SCK4C				P112
SCL				P117
STB	Output	Serial interface automatic transmit/receive strobe output.	Input	P23
BUSY	Input	Serial interface automatic transmit/receive busy input.	Input	P24
TI00	Input	External count clock input to 16-bit timer (TM0).	Input	P00/INTP0
TI01		Capture trigger signal input to capture register (CR00).		P01/INTP1
TI1		External count clock input to 8-bit timer (TM1).		P33
TI2		External count clock input to 8-bit timer (TM2).		P34
TI5		External count clock input to 8-bit timer (TM5).		P100/TO5
TI6		External count clock input to 8-bit timer (TM6).		P100/TO6
TO0	Output	16-bit timer (TM0) output (also used for 14-bit PWM output).	Input	P30
TO1		8-bit timer (TM1) output.		P31
TO2		8-bit timer (TM2) output.		P32
TO5		8-bit timer (TM5) output (also used for 8-bit PWM output).		P100/TI5
TO6		8-bit timer (TM6) output (also used for 8-bit PWM output).		P101/TI6
PCL	Output	Clock output (for main system clock, subsystem clock trimming).	Input	P35
BUZ	Output	Buzzer output.	Input	P36
AD0 to AD7	Input /output	Low-order address/data bus at external memory expansion.	Input	P40 to P47

3.2 Non-port Pins (2/2)

Pin Name	I/O	Function	After Reset	Alternate Function Pin
A0 to A7	Output	Low-order address bus at external memory expansion.	Input	P80 to P87
A8 to A15	Output	High-order address bus at external memory expansion.	Input	P50 to P57
\overline{RD}	Output	External memory read operation strobe signal output.	Input	P64
\overline{WR}		External memory write operation strobe signal output.		P65
\overline{WAIT}	Input	Wait insertion at external memory access.	Input	P66
ASTB	Output	Strobe output which externally latches the address information output to ports 4, 5 and 8 to access external memory.	Input	P67
ANI0 to ANI7	Input	A/D converter analog input.	Input	P10 to P17
AVREF	Input	A/D converter reference voltage input (shared with analog power supply).	—	—
AVSS	—	A/D converter ground potential. Same potential as V _{SS0} .	—	—
\overline{RESET}	Input	System reset input.	—	—
X1	Input	Main system clock oscillation crystal connection.	—	—
X2	—		—	—
XT1	Input	Subsystem clock oscillation crystal connection.	Input	—
XT2	—		—	—
VDD0	—	Port block positive power supply.	—	—
VSS0	—	Port block ground potential.	—	—
VDD1	—	Positive power supply (except for port and analog blocks)	—	—
VSS1	—	Ground potential (except for port and analog blocks)	—	—
IC	—	Internal connection. Connect directly to V _{SS0} .	—	—

3.3 Pin I/O Circuits and Recommended Connection of Unused Pins

The input/output circuit type of each pin and recommended connection of unused pins are shown in Table 3-1. For the input/output circuit configuration of each type, see Figure 3-1.

Table 3-1. Types of Pin Input/Output Circuits (1/2)

Pin Name	Input/Output Circuit Type	I/O	Recommended Connection for Unused Pins		
P00/INTP0/TI00	2	Input	Connect to V _{SS0} .		
P01/INTP1/TI01	8-C	Input/output	Connect to V _{SS0} via a resistor individually.		
P02/INTP2					
P03/INTP3					
P04/INTP4					
P05/INTP5					
P06/INTP6					
P10/ANI0-P17/ANI7	9-B	Input	Connect to V _{DD0} or V _{SS0} via a resistor individually.		
P20/SI1	8-C	Input/output			
P21/SO1	5-H				
P22/SCK1	8-C				
P23/STB	5-H				
P24/BUSY	8-C				
P25-P27	5-H				
P30/TO0-P32/TO2					
P33/TI1	8-C				
P34/TI2					
P35/PCL	5-H				
P36/BUZ					
P37					
P40/AD0-P47/AD7	5-N			Input/output	Connect to V _{DD0} via a resistor individually.
P50/A8-P57/A15	5-H			Input/output	Connect to V _{DD0} or V _{SS0} via a resistor individually.
P60-P63					
P64/RD					
P65/WR					
P66/WAIT					
P67/ASTB					
P80/A0-P87/A7					
P90/SI4A		8-C			
P91/SO4A		5-H			
P92/SCK4A		8-C			
P93/SI4B					
P94/SO4B	5-H				
P95/SCK4B	8-C				

Table 3-1. Types of Pin Input/Output Circuits (2/2)

Pin Name	Input/Output Circuit Type	I/O	Recommended Connection for Unused Pins
P100/TI5/TO5	8-C	Input/output	Connect to V_{DD0} or V_{SS0} via a resistor individually.
P101/TI6/TO6			
P102, P103	5-H		
P110/SI4C	8-C		
P111/SO4C	5-H		
P112/SCK4C	8-C		
P113-P115	5-H		
P116/SDA	10-B		
P117/SCL			
P150-P156	5-H		
RESET	2		
XT1	16	—	Connect to V_{DD0} .
XT2			Leave open.
AV_{REF}	—		Connect to V_{SS0} .
AV_{SS}			
IC			Connect to V_{SS0} .

Figure 3-1. Pin Input/Output Circuits

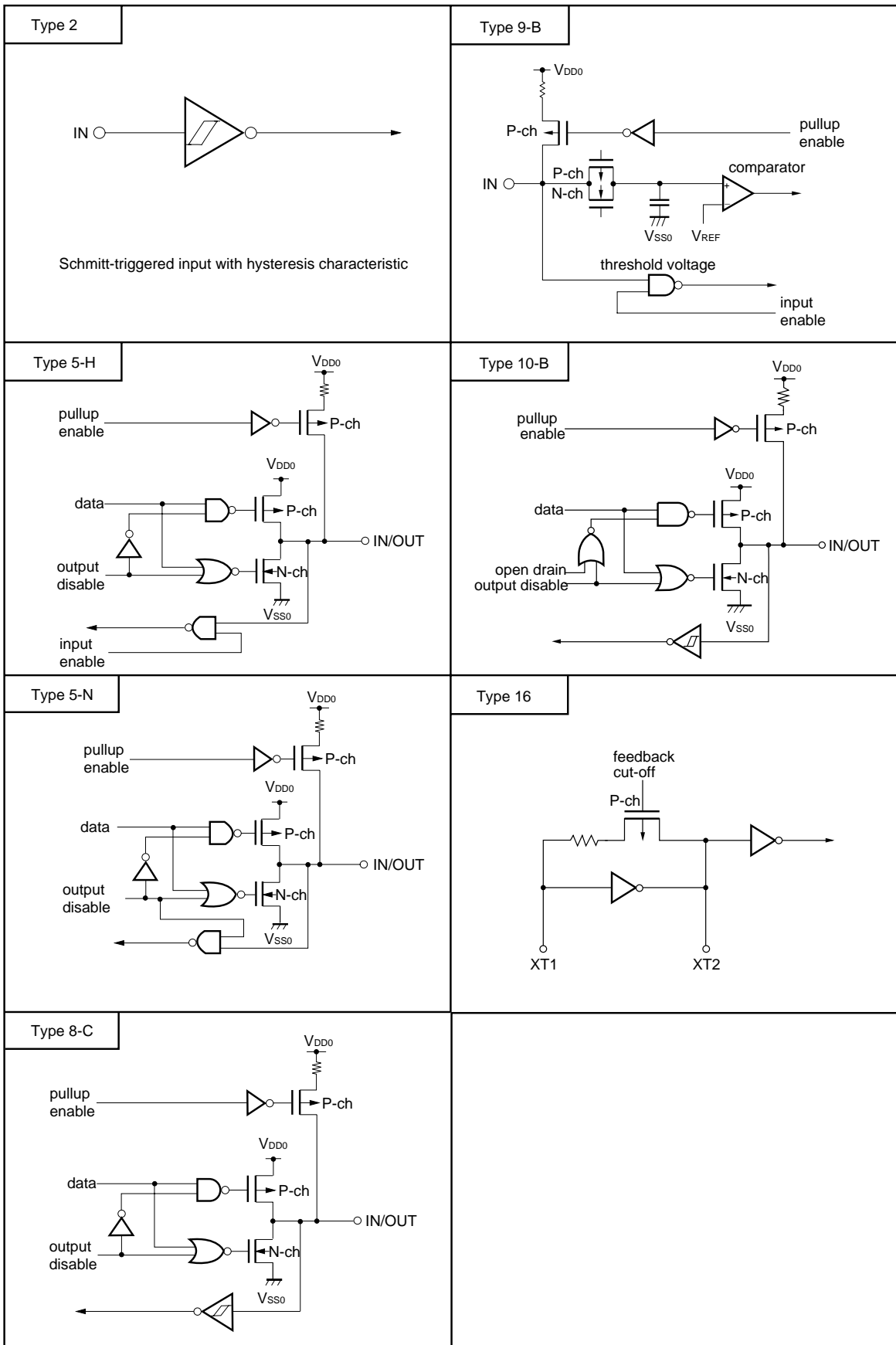

4. MEMORY SPACE

The memory map of the μPD780016Y and 780018Y is shown in Figure 4-1.

Figure 4-1. Memory Map

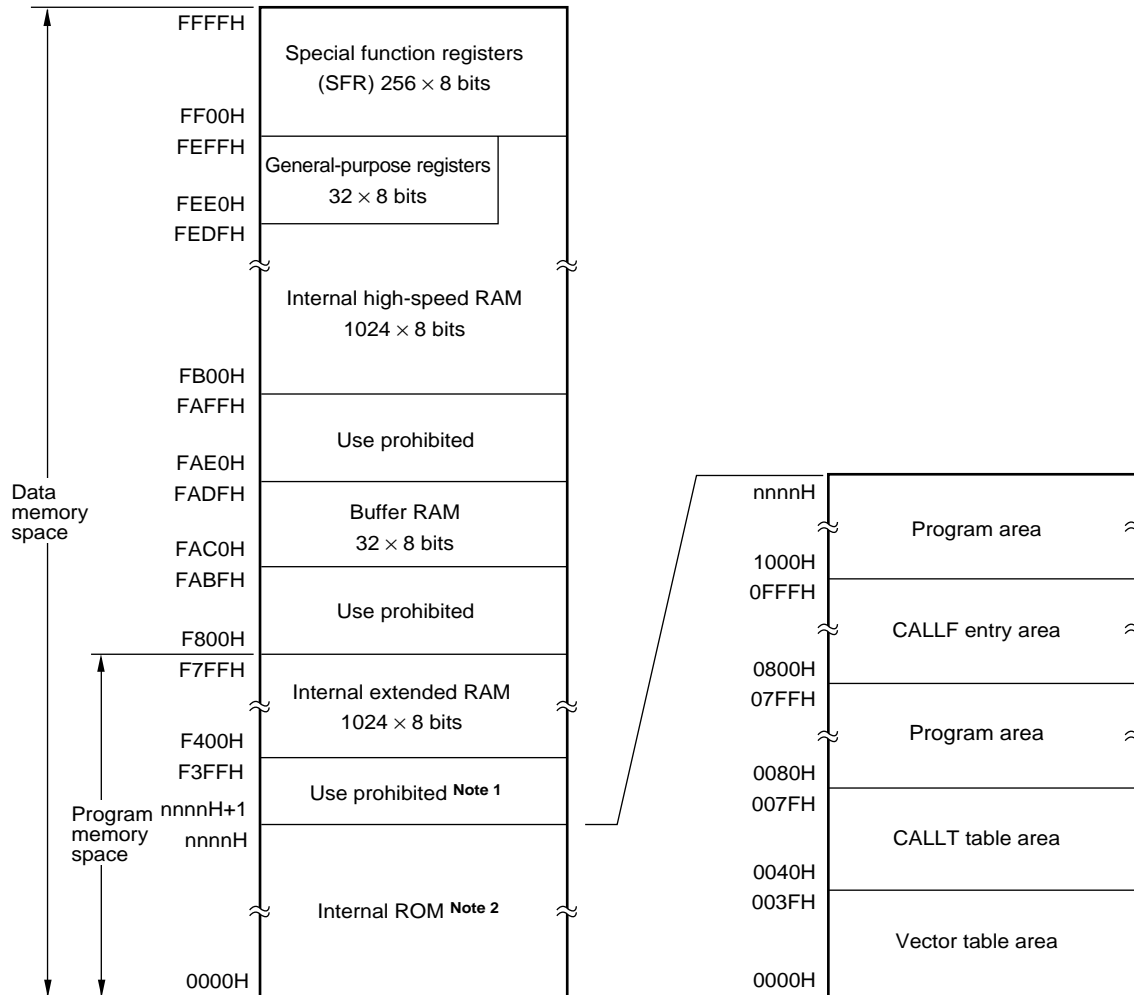

- Notes**
1. If external device expansion functions are to be employed for the μPD780018Y, set the size of the internal ROM to below 56K bytes using the memory size switching register (IMS).
 2. The internal ROM capacity depends on the product. (See the following table.)

Part Number	Internal ROM Last Address nnnnH
μPD780016Y	BFFFH
μPD780018Y	EFFFH

5. PERIPHERAL HARDWARE FUNCTIONS

5.1 Ports

Input/output ports are classified into two types.

- CMOS input (P00, Port 1) : 9
 - CMOS input/output (P01 to P06, Port 2 to 6, Port 8 to 11, Port 15) : 79
-
- Total : 88

Table 5-1. Functions of Ports

Port Name	Pin Name	Function
Port 0	P00	Input only.
	P01 to P06	Input/output port. Input/output can be specified bit-wise. When used as an input port, on-chip pull-up resistor can be used by software.
Port 1	P10 to P17	Input only. On-chip pull-up resistor can be used by software.
Port 2	P20 to P27	Input/output port. Input/output can be specified bit-wise. When used as an input port, on-chip pull-up resistor can be used by software.
Port 3	P30 to P37	Input/output port. Input/output can be specified bit-wise. When used as an input port, on-chip pull-up resistor can be used by software.
Port 4	P40 to P47	Input/output port. Input/output can be specified in 8-bit units. When used as an input port, on-chip pull-up resistor can be used by software. The test input flag (KRIF) is set to 1 by falling edge detection.
Port 5	P50 to P57	Input/output port. Input/output can be specified bit-wise. When used as an input port, on-chip pull-up resistor can be used by software. LED can be driven directly.
Port 6	P60 to P67	Input/output port. Input/output can be specified bit-wise. When used as an input port, on-chip pull-up resistor can be used by software.
Port 8	P80 to P87	Input/output port. Input/output can be specified bit-wise. When used as an input port, on-chip pull-up resistor can be used by software.
Port 9	P90 to P95	Input/output port. Input/output can be specified bit-wise. When used as an input port, on-chip pull-up resistor can be used by software.
Port 10	P100 to P103	Input/output port. Input/output can be specified bit-wise. When used as an input port, on-chip pull-up resistor can be used by software.
Port 11	P110 to P117	Input/output port. Input/output can be specified bit-wise. When used as an input port, on-chip pull-up resistor can be used by software.
Port 15	P150 to P156	Input/output port. Input/output can be specified bit-wise. When used as an input port, on-chip pull-up resistor can be used by software.

5.2 Clock Generator

There are two kinds of clock generators: main system and subsystem clock generators.

It is possible to change the instruction execution time.

- 0.4 μs/0.8 μs/1.6 μs/3.2 μs/6.4 μs (at main system clock frequency of 5.0 MHz)
- 122 μs (at subsystem clock frequency of 32.768 kHz)

Figure 5-1. Clock Generator Block Diagram

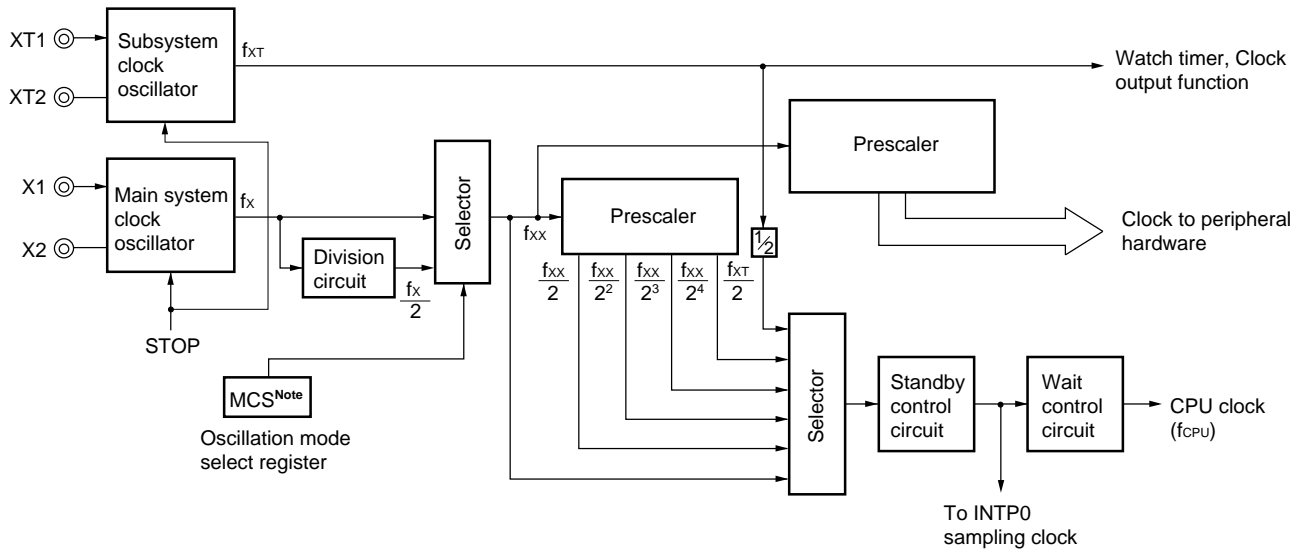

Note Be sure to set 1 to MCS.

5.3 Timer/Event Counter

There are the following seven timer/event counter channels:

- 16-bit timer/event counter : 1 channel
- 8-bit timer/event counter : 4 channels
- Watch timer : 1 channel
- Watchdog timer : 1 channel

Table 5-2. Types and Functions of Timer/Event Counters

		16-bit Timer/Event Counter	8-bit Timer/Event Counters 1, 2	8-bit Timer/Event Counters 5, 6	Watch Timer	Watchdog Timer
Type	Interval timer	1 channel	2 channels	2 channels	1 channel	1 channel
	External event counter	1 channel	2 channels	2 channels	—	—
Function	Timer output	1 output	2 outputs	2 outputs	—	—
	PWM output	1 output	—	2 outputs	—	—
	Pulse width measurement	2 inputs	—	—	—	—
	Square wave output	1 output	2 outputs	2 outputs	—	—
	One-shot pulse output	1 output	—	—	—	—
	Interrupt request	2	2	2	1	1
	Test input	—	—	—	1 input	—

Figure 5-2. 16-Bit Timer/Event Counter Block Diagram

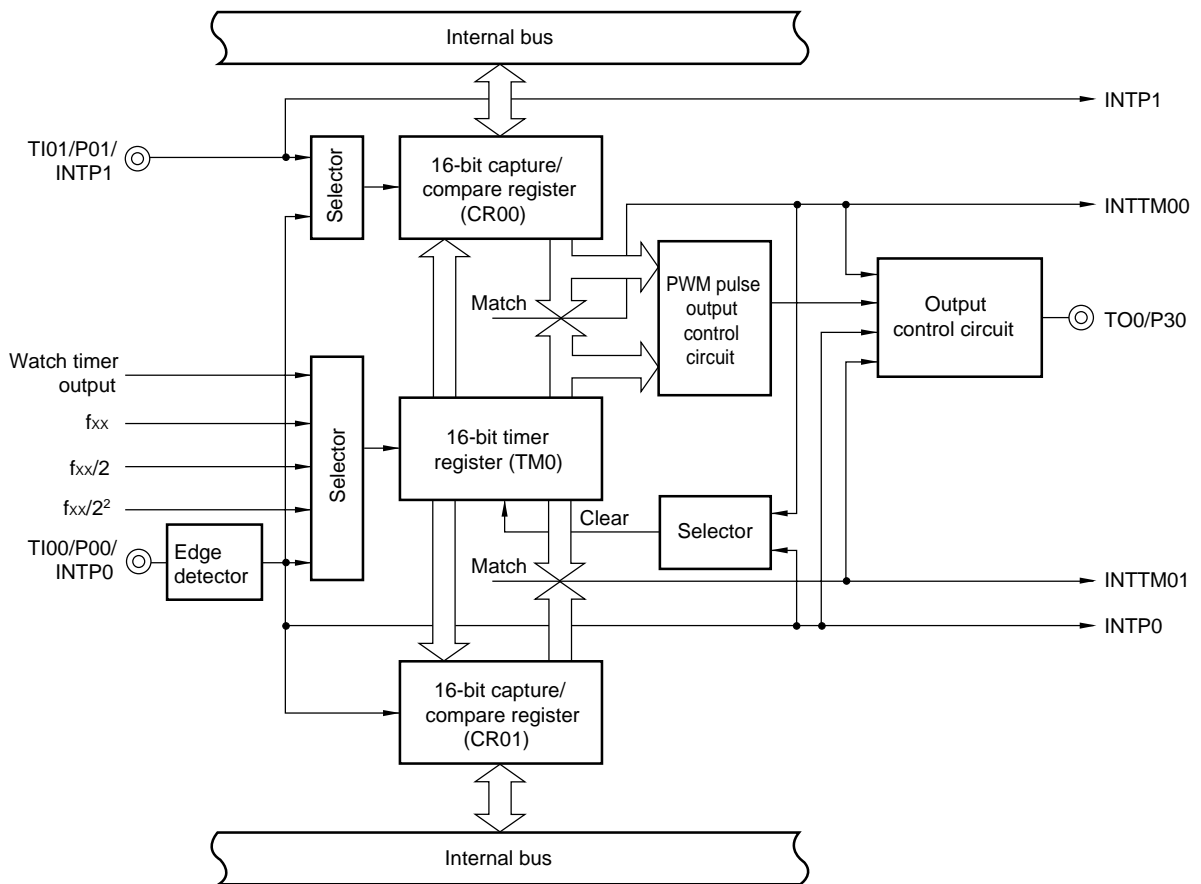

Figure 5-3. 8-Bit Timer/Event Counter 1, 2 Block Diagram

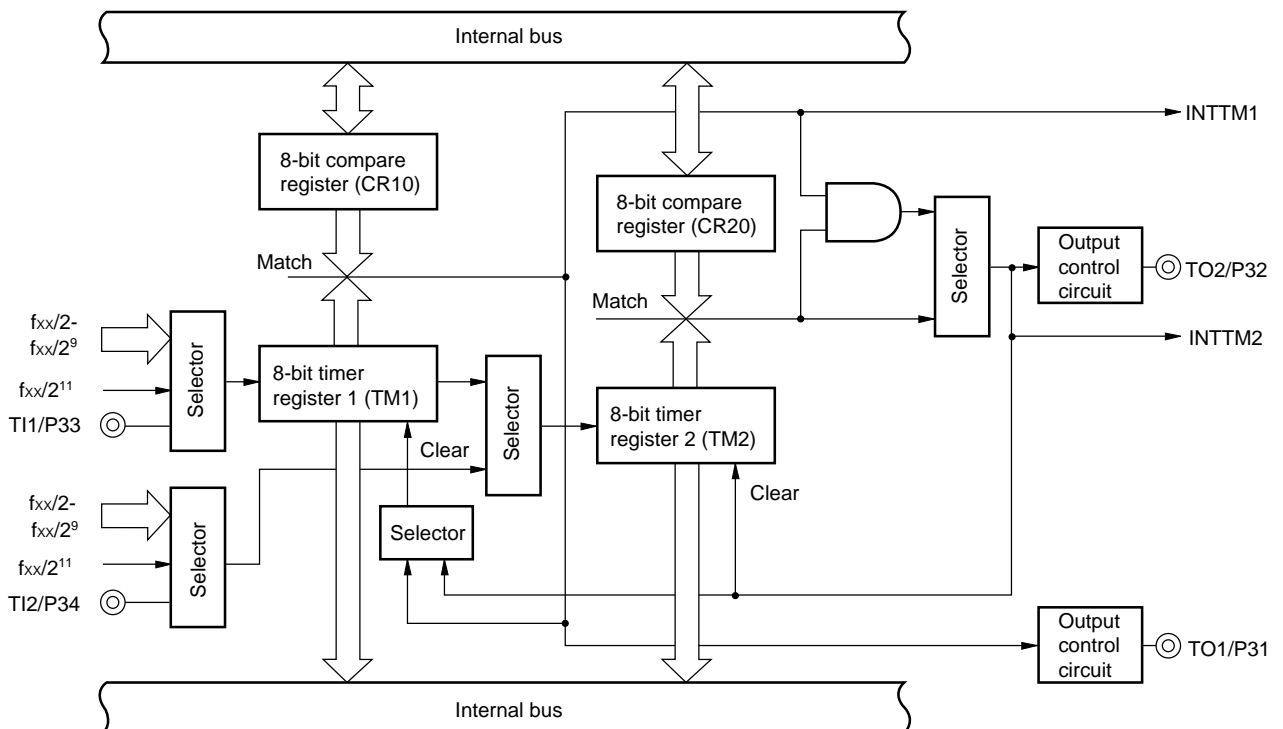
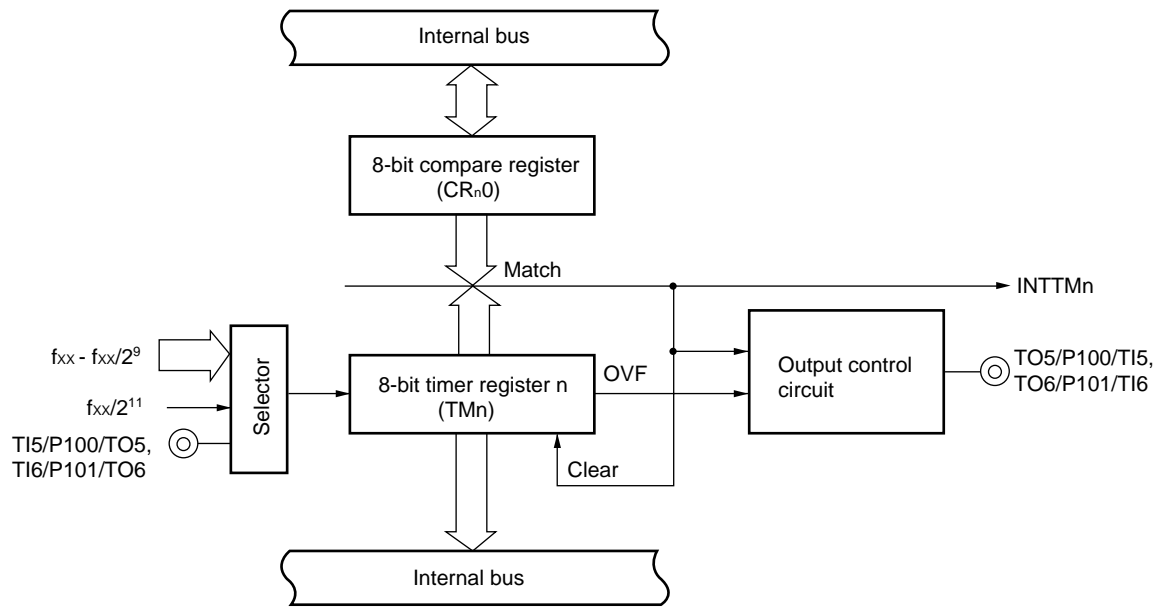

Figure 5-4. 8-Bit Timer/Event Counter 5, 6 Block Diagram



n = 5, 6

Figure 5-5. Watch Timer Block Diagram

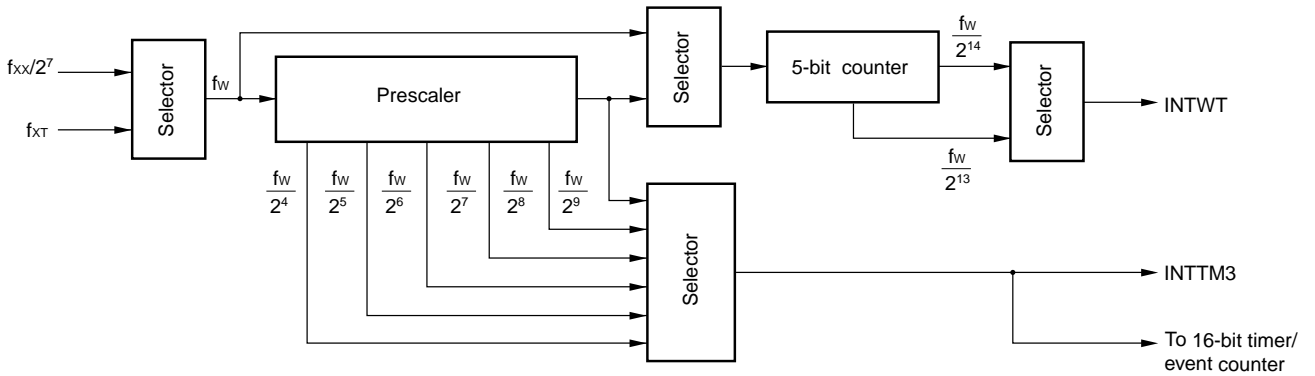
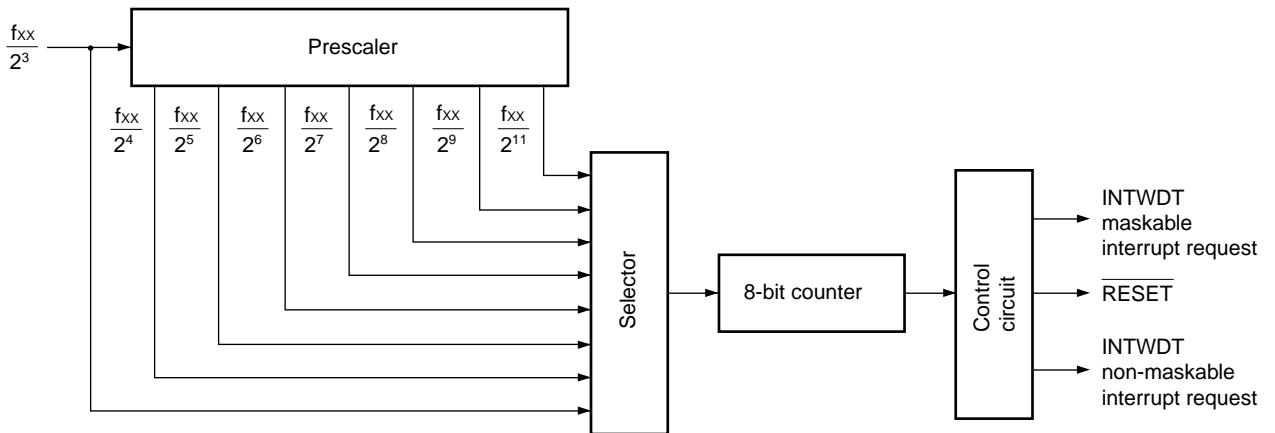

Figure 5-6. Watchdog Timer Block Diagram



5.4 Clock Output Control Circuit

This circuit can output clocks of the following frequencies:

- 39.1 kHz/78.1 kHz/156 kHz/313 kHz/625 kHz/1.25 MHz/2.5 MHz/5.0 MHz (at main system clock frequency of 5.0 MHz)
- 32.768 kHz (at subsystem clock frequency of 32.768 kHz)

Figure 5-7. Clock Output Control Circuit Block Diagram

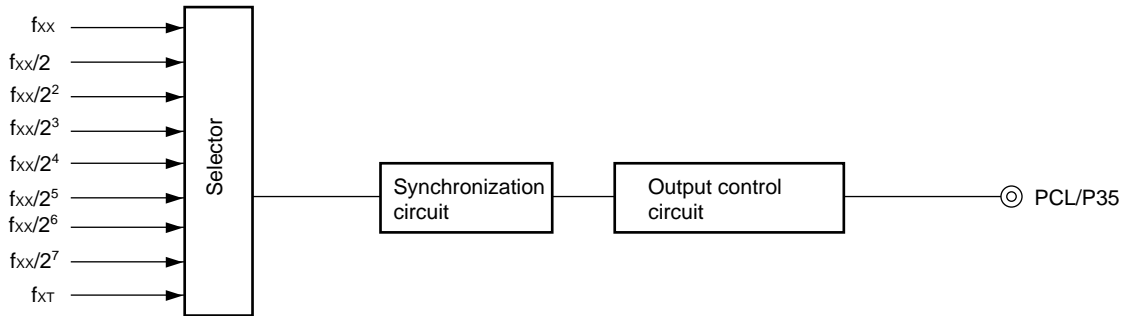

5.5 Buzzer Output Control Circuit

This circuit can output clocks of the following frequencies that can be used for driving buzzers:

- 2.4 kHz/4.9 kHz/9.8 kHz (at main system clock frequency of 5.0 MHz)

Figure 5-8. Buzzer Output Control Circuit Block Diagram

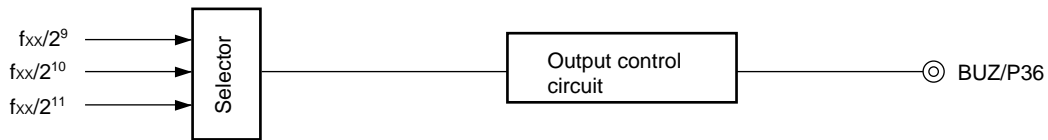

5.6 A/D Converter

The A/D converter consists of eight 8-bit resolution channels.

A/D conversion can be started by the following two methods:

- Hardware starting
- Software starting

Figure 5-9. A/D Converter Block Diagram

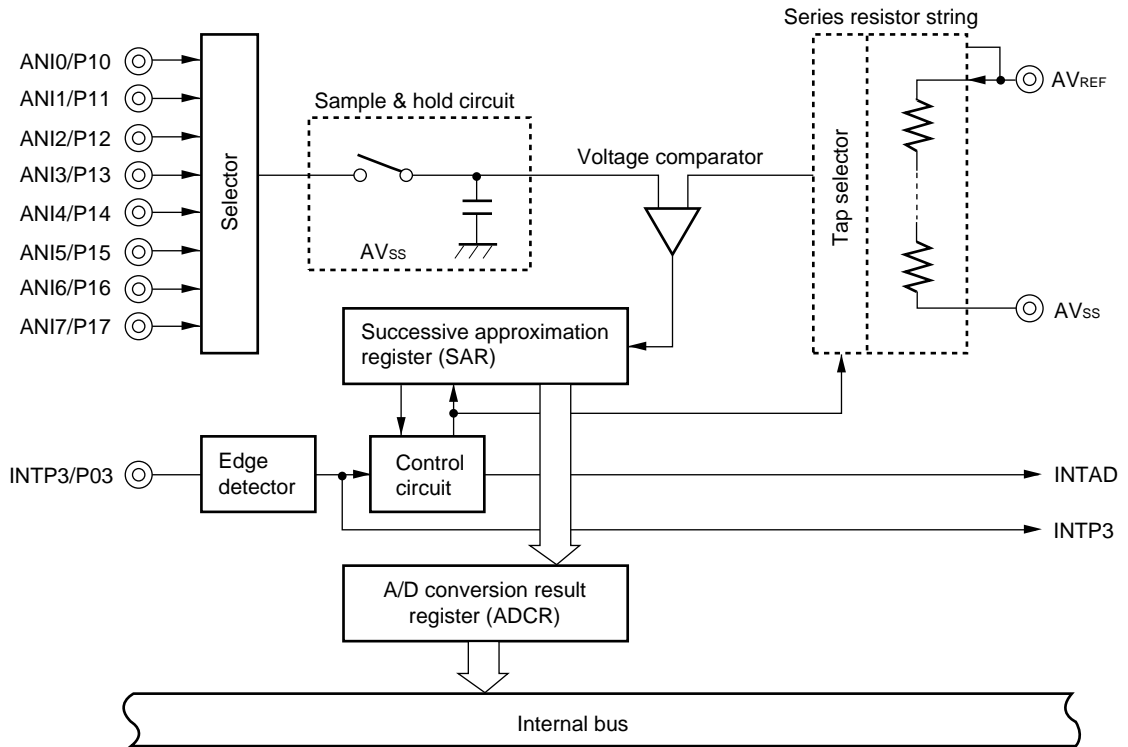

5.7 Serial Interfaces

There are the following three on-chip serial interface channels synchronous with the clock:

- Serial interface channel 1
- Serial interface channel 4
- Serial interface channel 5

Table 5-3. Types and Functions of Serial Interfaces

Function	Serial Interface Channel 1	Serial Interface Channel 4	Serial Interface Channel 5
3-wire serial I/O mode	○ (Starting bit MSB/LSB switching possible)	○ (Starting bit MSB/LSB switching possible)	—
3-wire serial I/O mode with automatic data transmit/ /receive function	○ (Starting bit MSB/LSB switching possible)	—	—
3-wire serial I/O mode with automatic data transmit/ receive function	—	○ (Starting bit MSB/LSB switching possible)	—
I ² C bus mode	—	—	○ (MSB first)

Figure 5-10. Serial Interface Channel 1 Block Diagram

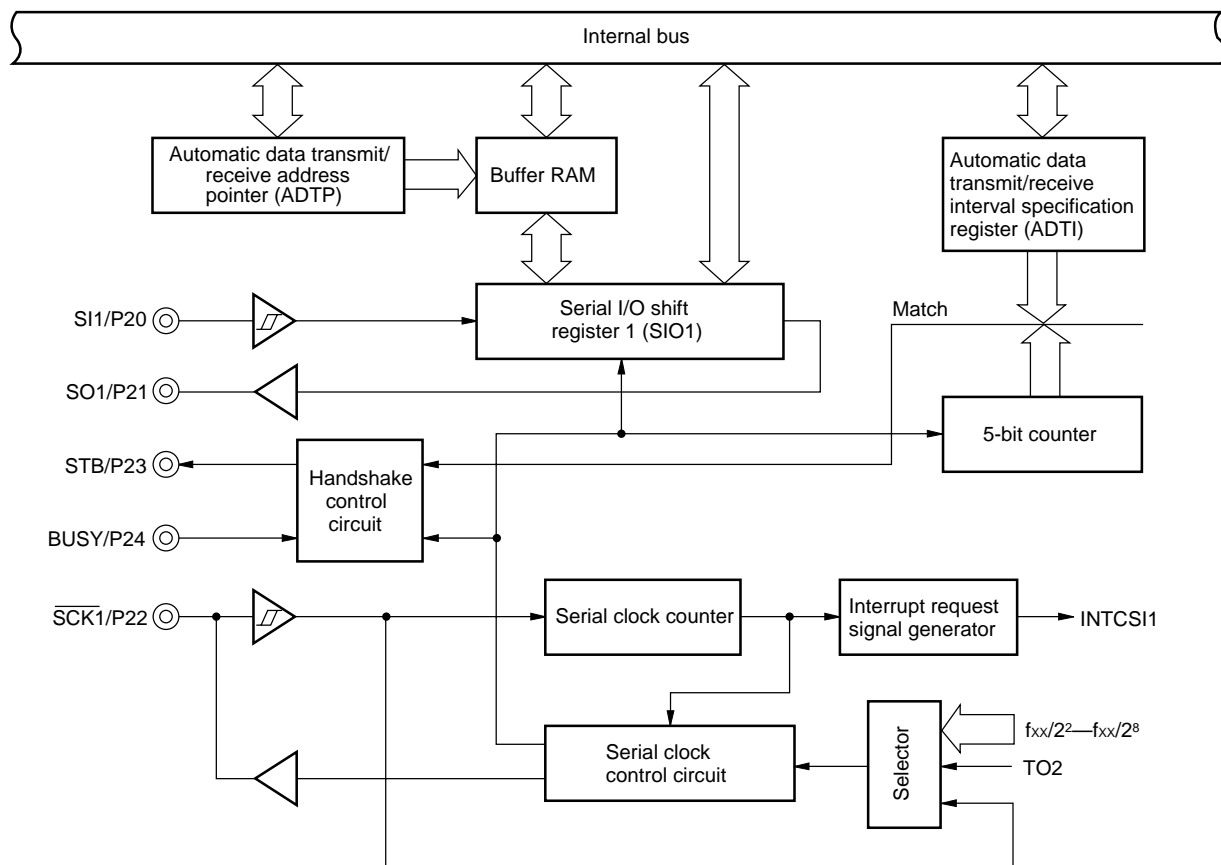

Figure 5-11. Serial Interface Channel 4 Block Diagram

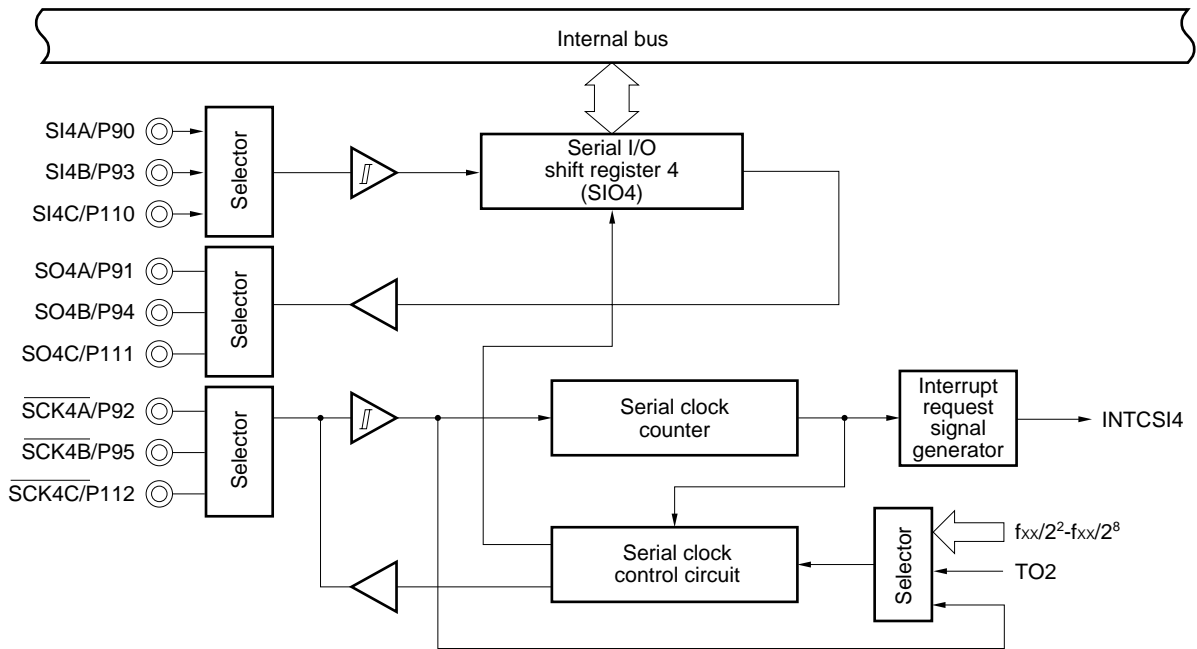
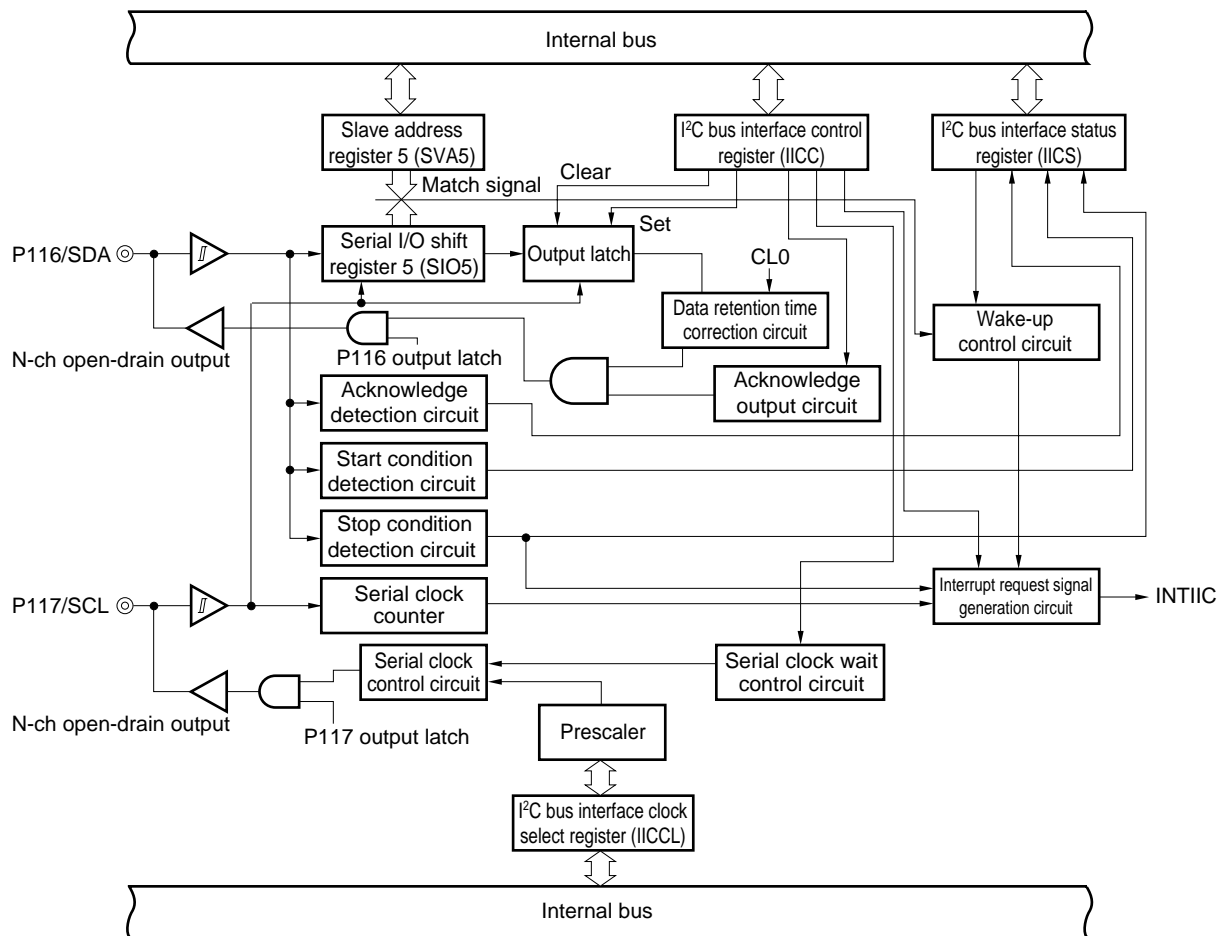

Figure 5-12. Serial Interface Channel 5 Block Diagram



6. INTERRUPT FUNCTIONS AND TEST FUNCTIONS

6.1 Interrupt Functions

A total of 21 interrupt functions are provided, divided into the following three types.

- Non-maskable : 1
- Maskable : 19
- Software : 1

Table 6-1. List of Interrupt Factors

Interrupt Type	Default ^{Note 1} Priority	Interrupt Factor		Internal/External	Vector Table Address	Basic ^{Note 2} Structure Type			
		Name	Trigger						
Non-maskable	—	INTWDT	Overflow of watchdog timer (When the watchdog timer mode 1 is selected)	Internal	0004H	(A)			
Maskable	0	INTWDT	Overflow of watchdog timer (When the interval timer mode is selected)			External	0006H 0008H 000AH 000CH 000EH 0010H 0012H	(B)	
	1	INTP0	Pin input edge detection	(C)					
	2	INTP1			(D)				
	3	INTP2							
	4	INTP3							
	5	INTP4							
	6	INTP5							
	7	INTP6							
	8	INTCSI1						Completion of serial interface channel 1 transfer	Internal
	9	INTTM3	Reference interval signal from watch timer						
	10	INTTM00	Generation of matching signal of 16-bit timer register and capture/compare register (CR00)						
	11	INTTM01	Generation of matching signal of 16-bit timer register and capture/compare register (CR01)						
	12	INTTM1	Generation of matching signal of 8-bit timer/event counter 1						
	13	INTTM2	Generation of matching signal of 8-bit timer/event counter 2						
	14	INTAD	Completion of A/D conversion						
	15	INTTM5	Generation of matching signal of 8-bit timer/event counter 5						
	16	INTTM6	Generation of matching signal of 8-bit timer/event counter 6						
	17	INTCSI4	Completion of serial interface channel 4 transfer						
	18	INTIIC	Completion of serial interface channel 5 transfer						
Software	—	BRK	Execution of BRK instruction	—	003EH	(E)			

Notes 1. Default priority is the priority order when several maskable interruptions are generated at the same time. 0 is the highest order and 18 is the lowest order.

2. Basic structure types (A) to (E) correspond to (A) to (E) in Figure 6-1.

Figure 6-1. Interrupt Function Basic Configuration (1/2)

(A) Internal non-maskable interrupt

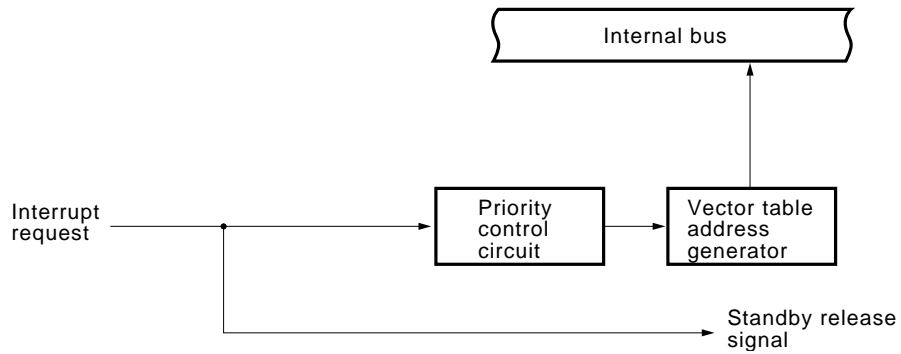

(B) Internal maskable interrupt

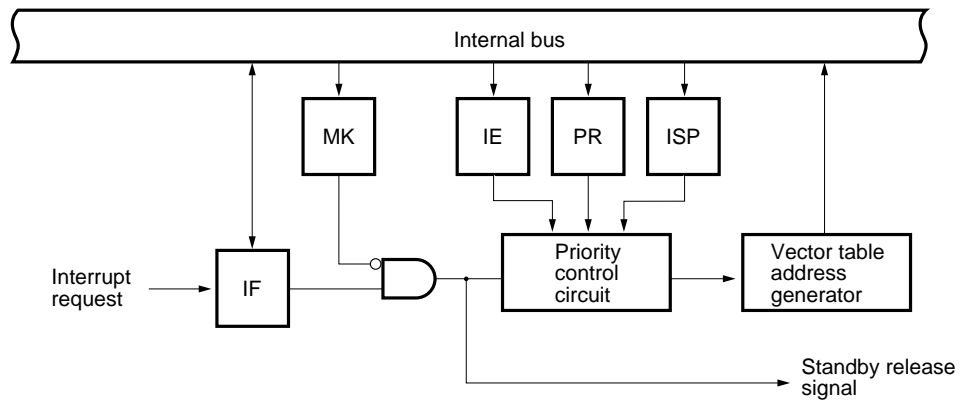

(C) External maskable interrupt (INTP0)

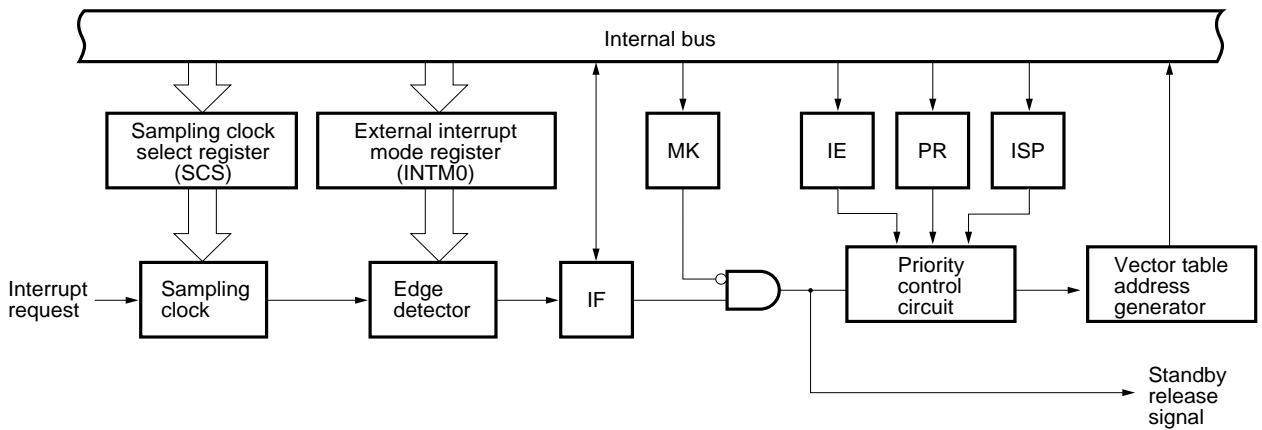
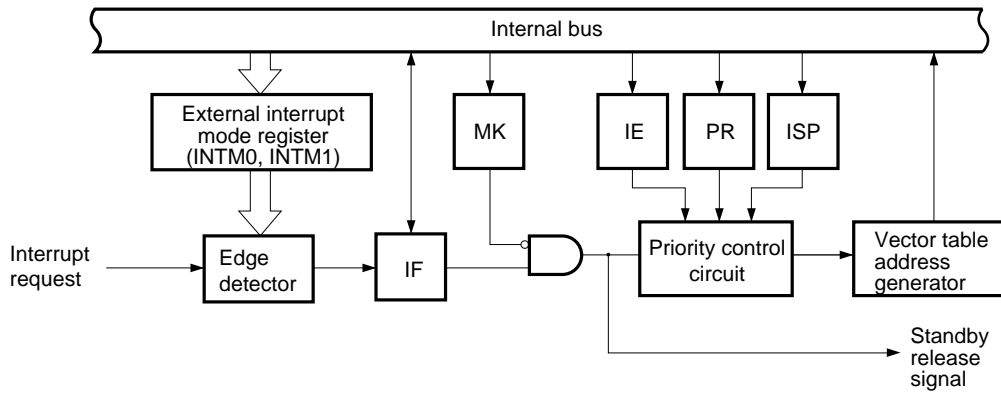
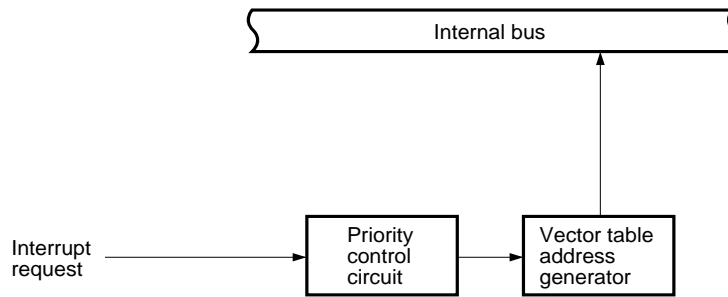

Figure 6-1. Interrupt Function Basic Configuration (2/2)

(D) External maskable interrupt (except INTP0)



(E) Software interrupt



- IF : Interrupt request flag
- E : Interrupt enable flag
- ISP : In-service priority flag
- MK : Interrupt mask flag
- PR : Priority specification flag

6.2 Test Functions

Table 6-2 shows the two test functions available.

Table 6-2. Test Input Factors

Test Input Factor		Internal/ External
Name	Trigger	
INTWT	Overflow of watch timer	Internal
INTPT4	Detection of falling edge of port 4	External

Figure 6-2. Basic Configuration of Test Function

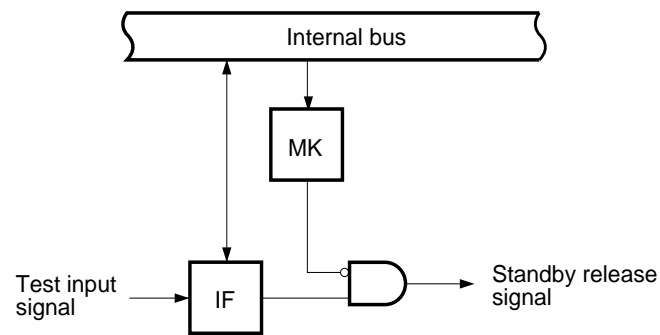

IF : Test input flag
 MK : Test mask flag

7. EXTERNAL DEVICE EXPANSION FUNCTIONS

The external device expansion functions connect external devices to areas other than the internal ROM, RAM and SFR.

External devices connection uses ports 4 to 6 and port 8.

The external device expansion function has the following two modes:

- Separate bus mode : External devices are connected by using an independent address bus and data bus. Because an external latch circuit is not necessary, this mode is effective for reducing the number of components and the mounting area on a printed wiring board.
- Multiplexed bus mode : External devices are connected by using a time-division multiplexed address/data bus. This mode is useful for reducing the number of ports used when external devices are connected.

8. STANDBY FUNCTION

The standby function intends to reduce current consumption. It has the following three modes:

- HALT mode : In this mode, the CPU operation clock is stopped. The average current consumption can be reduced by intermittent operation by combining this mode with the normal operation mode.
- Main STOP mode : In this mode, oscillation of the main system clock is stopped. The power consumption can be reduced because the whole internal circuit is stopped.
- Sub-STOP mode : In this mode, oscillation of the subsystem clock is stopped. The whole operation is stopped and the power is consumed very little.

Figure 8-1. Standby Function

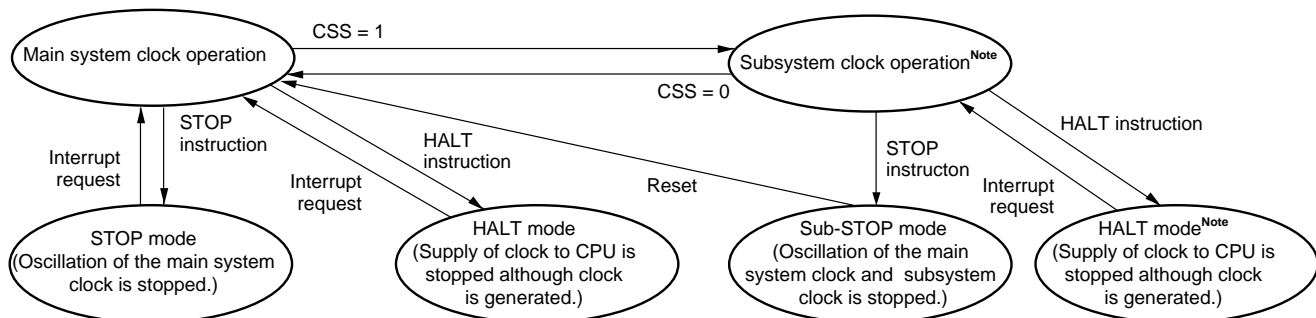

Note Current consumption is reduced by shutting off the main system clock. If the CPU is operating on subsystem clock, shut off the main system clock by setting MCC. You cannot use a STOP instruction in HALT mode.

- Cautions**
1. The main stop mode can be used only when the main system clock is being operated. (The oscillation of the subsystem clock cannot be stopped.)
 2. When switching on the main system clock again after the subsystem clock has been used with the main system clock stopped, be sure to provide enough time for the generation to be stable with the program first.

9. RESET FUNCTION

There are the following two reset methods.

- External reset input by $\overline{\text{RESET}}$ pin
- Internal reset by watchdog timer inadvertent program loop time detection

10. INSTRUCTION SET

(1) 8-bit instructions

MOV, XCH, ADD, ADDC, SUB, SUBC, AND, OR, XOR, CMP, MULU, DIVUW, INC, DEC, ROR, ROL, RORC, ROLC, ROR4, ROL4, PUSH, POP, DBNZ

2nd Operand 1st Operand	#byte	A	r ^{Note}	sfr	saddr	!addr16	PSW	[DE]	[HL]	[HL + byte] [HL + B] [HL + C]	\$addr16	1	None
A	ADD ADDC SUB SUBC AND OR XOR CMP		MOV XCH ADD ADDC SUB SUBC AND OR XOR CMP	MOV XCH	MOV XCH ADD ADDC SUB SUBC AND OR XOR CMP	MOV XCH ADD ADDC SUB SUBC AND OR XOR CMP	MOV	MOV XCH	MOV XCH ADD ADDC SUB SUBC AND OR XOR CMP	MOV XCH ADD ADDC SUB SUBC AND OR XOR CMP		ROR ROL RORC ROLC	
r	MOV	MOV ADD ADDC SUB SUBC AND OR XOR CMP											INC DEC
B, C											DBNZ		
sfr	MOV	MOV											
saddr	MOV ADD ADDC SUB SUBC AND OR XOR CMP	MOV									DBNZ		INC DEC
!addr16		MOV											
PSW	MOV	MOV											PUSH POP
[DE]		MOV											
[HL]		MOV											ROR4 ROL4
[HL + byte] [HL + B] [HL + C]		MOV											
X													MULU
C													DIVUW

Note Except r = A

(2) 16-bit instructions

MOVW, XCHW, ADDW, SUBW, CMPW, PUSH, POP, INCW, DECW

1st Operand \ 2nd Operand	#word	AX	rp ^{Note}	sfrp	saddrp	!addr16	SP	None
AX	ADDW SUBW CMPW		MOVW XCHW	MOVW	MOVW	MOVW	MOVW	
rp	MOVW	MOVW ^{Note}						INCW, DECW PUSH, POP
sfrp	MOVW	MOVW						
saddrp	MOVW	MOVW						
!addr16		MOVW						
SP	MOVW	MOVW						

Note Only when rp = BC, DE, HL

(3) Bit manipulation instructions

MOV1, AND1, OR1, XOR1, SET1, CLR1, NOT1, BT, BF, BTCLR

1st Operand \ 2nd Operand	A.bit	sfr.bit	saddr.bit	PSW.bit	[HL].bit	CY	\$addr16	None
A.bit						MOV1	BT BF BTCLR	SET1 CLR1
sfr.bit						MOV1	BT BF BTCLR	SET1 CLR1
saddr.bit						MOV1	BT BF BTCLR	SET1 CLR1
PSW.bit						MOV1	BT BF BTCLR	SET1 CLR1
[HL].bit						MOV1	BT BF BTCLR	SET1 CLR1
CY	MOV1 AND1 OR1 XOR1	MOV1 AND1 OR1 XOR1	MOV1 AND1 OR1 XOR1	MOV1 AND1 OR1 XOR1	MOV1 AND1 OR1 XOR1			SET1 CLR1 NOT1

(4) Call instructions/Branch instructions

CALL, CALLF, CALLT, BR, BC, BNC, BZ, BNZ, BT, BF, BTCLR, DBNZ

1st Operand \ 2nd Operand	AX	!addr16	!addr11	[addr5]	\$addr16
Basic instruction	BR	CALL BR	CALLF	CALLT	BR, BC BNC BZ, BNZ
Compound instruction					BT, BF BTCLR DBNZ

(5) Other instructions

ADJBA, ADJBS, BRK, RET, RETI, RETB, SEL, NOP, EI, DI, HALT, STOP

11. PACKAGE DRAWINGS

100 PIN PLASTIC QFP (14 × 20)

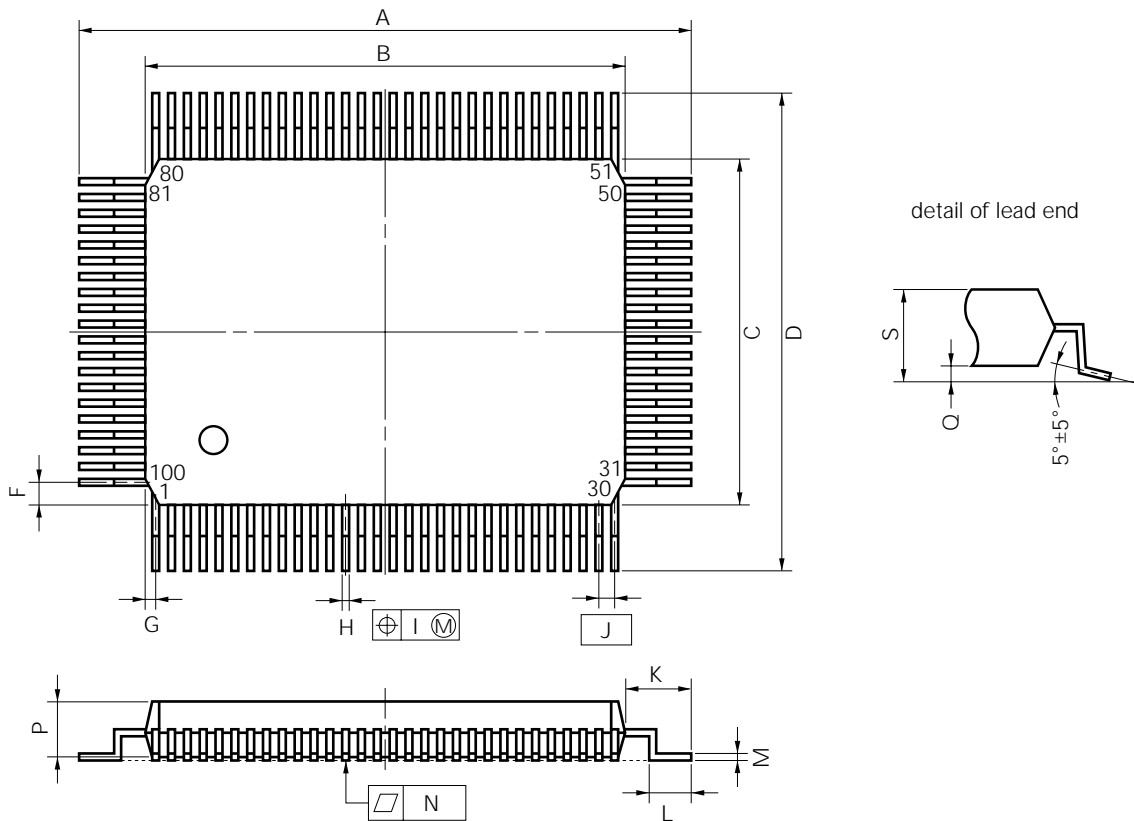

NOTE

Each lead centerline is located within 0.15 mm (0.006 inch) of its true position (T.P.) at maximum material condition.

P100GF-65-3BA1-2

ITEM	MILLIMETERS	INCHES
A	23.6±0.4	0.929±0.016
B	20.0±0.2	0.795 ^{+0.009} _{-0.008}
C	14.0±0.2	0.551 ^{+0.009} _{-0.008}
D	17.6±0.4	0.693±0.016
F	0.8	0.031
G	0.6	0.024
H	0.30±0.10	0.012 ^{+0.004} _{-0.005}
I	0.15	0.006
J	0.65 (T.P.)	0.026 (T.P.)
K	1.8±0.2	0.071 ^{+0.008} _{-0.009}
L	0.8±0.2	0.031 ^{+0.009} _{-0.008}
M	0.15 ^{+0.10} _{-0.05}	0.006 ^{+0.004} _{-0.003}
N	0.10	0.004
P	2.7	0.106
Q	0.1±0.1	0.004±0.004
S	3.0 MAX.	0.119 MAX.

APPENDIX A. DEVELOPMENT TOOLS

The following tools are available for system development using the μ PD780016Y and 780018Y.

Language Processing Software

RA78K/0 ^{Notes 1, 2, 3, 4}	Assembler package used in common for the 78K/0 series
CC78K/0 ^{Notes 1, 2, 3, 4}	C compiler package used in common for the 78K/0 series
DF780018 ^{Notes 1, 2, 3, 4, 8}	Device file used in common for the μ PD780018 subseries
CC78K/0-L ^{Notes 1, 2, 3, 4}	C compiler library source file used in common for the 78K/0 series

PROM Writing Tools

PG-1500	PROM programmer
PA-78P0018GF ^{Note 8}	Programmer adapter connected to the PG-1500
PA-78P0018KL-T ^{Note 8}	
PG-1500 controller ^{Notes 1, 2}	Control program for the PG-1500

Debugging Tools

IE-78000-R	In-circuit emulator used in common for the 78K/0 series
IE-78000-R-A ^{Note 8}	In-circuit emulator used in common for the 78K/0 series (for integrated debugger)
IE-78000-R-BK	Break board used in common for the 78K/0 series
IE-780018-R-EM ^{Note 8}	Emulation board used in common for the μ PD780018 subseries
EP-78064GF-R	Emulation probe used in common for the μ PD78064 subseries
EV-9200GF-100	Socket mounted on the target system board prepared for 100-pin plastic QFP (GF-3BA type)
EV-9900	Tool used for removing the μ PD78P0018YKL-T from the EV-9200GF-100.
SM78K0 ^{Notes 5, 6, 7}	System simulator used in common for the 78K/0 series
ID78K0 ^{Notes 4, 5, 6, 7, 8}	Integrated debugger for IE-78000-R-A
SD78K/0 ^{Notes 1, 2}	Screen debugger for the IE-78000-R
DF780018 ^{Notes 1, 2, 4, 5, 6, 7, 8}	Device file used in common for the μ PD780018 subseries

Real-Time OS

RX78K/0 ^{Notes 1, 2, 3, 4}	Real-time OS used for the 78K/0 series
MX78K0 ^{Notes 1, 2, 3, 4}	OS used for the 78K/0 series

Fuzzy Inference Development Support System

FE9000 ^{Note 1} /FE9200 ^{Note 6}	Fuzzy knowledge data creating tool
FT9080 ^{Note 1} /FT9085 ^{Note 2}	Translator
FI78K0 ^{Notes 1, 2}	Fuzzy inference module
FD78K0 ^{Notes 1, 2}	Fuzzy inference debugger

- Notes**
1. Based on PC-9800 series (MS-DOS™)
 2. Based on IBM PC/AT™ and compatible machines (PC DOS™/IBM DOS™/MS-DOS)
 3. Based on HP9000 series 300™ (HP-UX™)
 4. Based on HP9000 series 700™ (HP-UX), SPARCstation™ (SunOS™), and EWS-4800 series (EWS-UX/V)
 5. Based on PC-9800 series (MS-DOS + Windows™)
 6. Based on IBM PC/AT and compatible machines (PC DOS/IBM DOS/MS DOS + Windows)
 7. Based on NEW™ (NEWS-OS™)
 8. Under development

- Remarks**
1. For development tools supplied by third-party manufacturers, refer to **78K/0 Series Selection Guide** (U11126E).
 2. Use the RA78K/0, CC78K/0, SM78K0, ID78K0, SD78K/0, and RX78K/0 in combination with the DF780018.

APPENDIX B. RELATED DOCUMENTS

Documents Related to Devices

Document	Document No.	
	Japanese	English
μPD780018Y, 780018Y Subseries User's Manual	U11754J	To be prepared
μPD780016Y, 780018Y Preliminary Product Information	U11810J	This document
μPD78P0018Y Preliminary Product Information	U11603J	To be prepared
78K/0 Series User's Manual-Instruction	IEU-849	IEU-1372
78K/0 Series Instruction Table	U10903J	—
78K/0 Series Instruction Set	U10904J	—
μPD780018Y Subseries Special-Function Register Table	To be prepared	—

Documents on Development Tools (User's Manuals)

Document		Document No.	
		Japanese	English
RA78K Series Assembler Package	Operation	EEU-809	EEU-1399
	Language	EEU-815	EEU-1404
RA78K Series Structured Assembler Preprocessor		EEU-817	EEU-1402
CC78K Series C Compiler	Operation	EEU-656	EEU-1280
	Language	EEU-655	EEU-1284
CC78K0 C Compiler	Operation	U11517J	—
	Language	U11518J	—
CC78K/0 C Compiler Application Note	Programing Know-how	EEA-618	EEA-1208
CC78K Series Library Source File		EEU-777	—
PG-1500 PROM Programmer		EEU-651	EEU-1335
PG-1500 Controller PC-9800 Series (MS-DOS) Base		EEU-704	EEU-1291
PG-1500 Controller IBM PC Series (PC-DOS) Base		EEU-5008	U10540E
IE-78000-R		EEU-810	U11376E
IE-78000-R-A		U10057J	U10057E
IE-78000-R-BK		EEU-867	EEU-1427
IE-780018-R-EM		U11838J	To be prepared
EP-78064		EEU-934	EEU-1469
SM78K0 System Simulator Windows Base	Reference	U10181J	U10181E
SM78K Series System Simulator	External component user open interface specification	U10092J	U10092E
ID78K0 Integrated Debugger EWS Base	Reference	U11151J	—
ID78K0 Integrated Debugger PC Base	Reference	U11539J	—
ID78K0 Integrated Debugger Windows Base	Guide	U11649J	—
SD78K/0 Screen Debugger PC-9800 Series (MS-DOS) Base	Introduction	EEU-852	—
	Reference	U10952J	—
SD78K/0 Screen Debugger	Introduction	EEU-5024	EEU-1414
IBM PC/AT (PC DOS) Base	Reference	U11279J	EEU-1413

Caution The above documents are subject to change without notice. Be sure to use the latest documents for design or for any other similar purpose.

Documents on Embeded Software (User's Manuals)

Document		Document No.	
		Japanese	English
78K/0 Series Real-time OS	Basic	U11537J	—
	Installation	U11536J	—
	Technical	U11538J	—
78K/0 Series OS MX78K0	Fundamental	EEU-5010	—
Fuzzy Knowledge Data Creation Tool		EEU-829	EEU-1438
78K/0, 78K/II, 87AD Series Fuzzy Inference Development Support System Translator		EEU-862	EEU-1444
78K/0 Series Fuzzy Inference Development Support System Fuzzy Inference Module		EEU-858	EEU-1441
78K/0 Series Fuzzy Inference Development Support System Fuzzy Inference Debugger		EEU-921	EEU-1458

Other Documents

Document		Document No.	
		Japanese	English
IC Package Manual		C10943X	
Semiconductor Device Mounting Technology Manual		C10535J	C10535E
Quality Grade on NEC Semiconductor Devices		C11531J	C11531E
NEC Semiconductor Device Reliability/Quality Control System		U10983J	U10983E
Electrostatic Discharge (ESD) Test		MEM-539	—
Semiconductor Device Quality Assurance Guide		MEI-603	MEI-1202
Microcontroller-Related Product Guide – Third Party Products –		U11416J	—

Caution The above documents are subject to change without notice. Be sure to use the latest documents for design or for any other similar purpose.

[MEMO]

NOTES FOR CMOS DEVICES

① PRECAUTION AGAINST ESD FOR SEMICONDUCTORS

Note: Strong electric field, when exposed to a MOS device, can cause destruction of the gate oxide and ultimately degrade the device operation. Steps must be taken to stop generation of static electricity as much as possible, and quickly dissipate it once, when it has occurred. Environmental control must be adequate. When it is dry, humidifier should be used. It is recommended to avoid using insulators that easily build static electricity. Semiconductor devices must be stored and transported in an anti-static container, static shielding bag or conductive material. All test and measurement tools including work bench and floor should be grounded. The operator should be grounded using wrist strap. Semiconductor devices must not be touched with bare hands. Similar precautions need to be taken for PW boards with semiconductor devices on it.

② HANDLING OF UNUSED INPUT PINS FOR CMOS

Note: No connection for CMOS device inputs can be cause of malfunction. If no connection is provided to the input pins, it is possible that an internal input level may be generated due to noise, etc., hence causing malfunction. CMOS device behave differently than Bipolar or NMOS devices. Input levels of CMOS devices must be fixed high or low by using a pull-up or pull-down circuitry. Each unused pin should be connected to V_{DD} or GND with a resistor, if it is considered to have a possibility of being an output pin. All handling related to the unused pins must be judged device by device and related specifications governing the devices.

③ STATUS BEFORE INITIALIZATION OF MOS DEVICES

Note: Power-on does not necessarily define initial status of MOS device. Production process of MOS does not define the initial operation status of the device. Immediately after the power source is turned ON, the devices with reset function have not yet been initialized. Hence, power-on does not guarantee out-pin levels, I/O settings or contents of registers. Device is not initialized until the reset signal is received. Reset operation must be executed immediately after power-on for devices having reset function.

Regional Information

Some information contained in this document may vary from country to country. Before using any NEC product in your application, please contact the NEC office in your country to obtain a list of authorized representatives and distributors. They will verify:

- Device availability
- Ordering information
- Product release schedule
- Availability of related technical literature
- Development environment specifications (for example, specifications for third-party tools and components, host computers, power plugs, AC supply voltages, and so forth)
- Network requirements

In addition, trademarks, registered trademarks, export restrictions, and other legal issues may also vary from country to country.

NEC Electronics Inc. (U.S.)

Santa Clara, California
Tel: 800-366-9782
Fax: 800-729-9288

NEC Electronics (Germany) GmbH

Duesseldorf, Germany
Tel: 0211-65 03 02
Fax: 0211-65 03 490

NEC Electronics (UK) Ltd.

Milton Keynes, UK
Tel: 01908-691-133
Fax: 01908-670-290

NEC Electronics Italiana s.r.l.

Milano, Italy
Tel: 02-66 75 41
Fax: 02-66 75 42 99

NEC Electronics (Germany) GmbH

Benelux Office
Eindhoven, The Netherlands
Tel: 040-2445845
Fax: 040-2444580

NEC Electronics (France) S.A.

Velizy-Villacoublay, France
Tel: 01-30-67 58 00
Fax: 01-30-67 58 99

NEC Electronics (France) S.A.

Spain Office
Madrid, Spain
Tel: 01-504-2787
Fax: 01-504-2860

NEC Electronics (Germany) GmbH

Scandinavia Office
Taeby, Sweden
Tel: 08-63 80 820
Fax: 08-63 80 388

NEC Electronics Hong Kong Ltd.

Hong Kong
Tel: 2886-9318
Fax: 2886-9022/9044

NEC Electronics Hong Kong Ltd.

Seoul Branch
Seoul, Korea
Tel: 02-528-0303
Fax: 02-528-4411

NEC Electronics Singapore Pte. Ltd.

United Square, Singapore 1130
Tel: 253-8311
Fax: 250-3583

NEC Electronics Taiwan Ltd.

Taipei, Taiwan
Tel: 02-719-2377
Fax: 02-719-5951

NEC do Brasil S.A.

Sao Paulo-SP, Brasil
Tel: 011-889-1680
Fax: 011-889-1689

Purchase of NEC I²C components conveys a license under the Philips I²C Patent Rights to use these components in an I²C system, provided that the system conforms to the I²C Standard Specification as defined by Philips.

FIP is a trademark of NEC Corp.

IEBus is a trademark of NEC Corp.

MS-DOS and Windows are trademarks of Microsoft Corp.

IBM DOS, PC/AT, and PC DOS are trademarks of IBM Corp.

HP9000 series 300, HP9000 series 700, and HP-UX are trademarks of Hewlett Packard Co.

SPARCstation is a trademark of SPARC International, Inc.

SunOS is a trademark of Sun Microsystems, Inc.

NEWS and NEWS-OS are trademarks of Sony Corp.

The related documents in this publication may include preliminary versions, but may not be marked as such.

The export of this product from Japan is regulated by the Japanese government. To export this product may be prohibited without governmental license, the need for which must be judged by the customer. The export or re-export of this product from a country other than Japan may also be prohibited without a license from that country. Please call an NEC sales representative.

No part of this document may be copied or reproduced in any form or by any means without the prior written consent of NEC Corporation. NEC Corporation assumes no responsibility for any errors which may appear in this document.

NEC Corporation does not assume any liability for infringement of patents, copyrights or other intellectual property rights of third parties by or arising from use of a device described herein or any other liability arising from use of such device. No license, either express, implied or otherwise, is granted under any patents, copyrights or other intellectual property rights of NEC Corporation or others.

While NEC Corporation has been making continuous effort to enhance the reliability of its semiconductor devices, the possibility of defects cannot be eliminated entirely. To minimize risks of damage or injury to persons or property arising from a defect in an NEC semiconductor device, customers must incorporate sufficient safety measures in its design, such as redundancy, fire-containment, and anti-failure features.

NEC devices are classified into the following three quality grades:

"Standard", "Special", and "Specific". The Specific quality grade applies only to devices developed based on a customer designated "quality assurance program" for a specific application. The recommended applications of a device depend on its quality grade, as indicated below. Customers must check the quality grade of each device before using it in a particular application.

Standard: Computers, office equipment, communications equipment, test and measurement equipment, audio and visual equipment, home electronic appliances, machine tools, personal electronic equipment and industrial robots

Special: Transportation equipment (automobiles, trains, ships, etc.), traffic control systems, anti-disaster systems, anti-crime systems, safety equipment and medical equipment (not specifically designed for life support)

Specific: Aircrafts, aerospace equipment, submersible repeaters, nuclear reactor control systems, life support systems or medical equipment for life support, etc.

The quality grade of NEC devices is "Standard" unless otherwise specified in NEC's Data Sheets or Data Books. If customers intend to use NEC devices for applications other than those specified for Standard quality grade, they should contact an NEC sales representative in advance.

Anti-radioactive design is not implemented in this product.