

Features

- 4:1 Mux
- Triple channels
- $\pm 5V$ operation
- Gain of 1 (EL4344C)
- Gain of 2 (EL4348C)
- 600MHz bandwidth
- Supply current of 11mA/channel

Applications

- HDTV/DTV Analog Inputs
- Video Projectors
- Computer Monitors
- Set Top Boxes
- Security Video
- Broadcast Video Equipment

Ordering Information

Part No.	Package	Tape & Reel	Outline #
EL4344CU	28-Pin QSOP		MDP0040
EL4348CU	28-Pin QSOP		MDP0040

General Description

The EL4344C and EL4348C are 600MHz bandwidth multiplexing amplifiers designed primarily for input video switching. The EL4344C and EL4348C contain 4:1 multiplexing amplifiers.

The EN pin can be used to tri-state the MUX output, enabling parts to be paralleled for a greater number of inputs. All logic inputs are referenced to the GND pin.

The EL4344C has a gain of 1 and the EL4348C has a gain of 2.

The EL4344C and the EL4348C are available in a 28-pin QSOP package and are specified for operation over the full $-40^{\circ}C$ to $+85^{\circ}C$ temperature range.

Connection Diagram

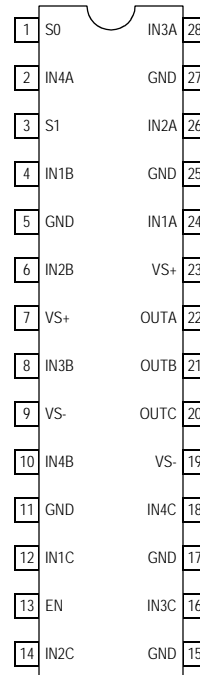

EL4344C & EL4348C
(28-Pin QSOP)

Note: All information contained in this data sheet has been carefully checked and is believed to be accurate as of the date of publication; however, this data sheet cannot be a "controlled document". Current revisions, if any, to these specifications are maintained at the factory and are available upon your request. We recommend checking the revision level before finalization of your design documentation.

EL4344C/EL4348C - Preliminary

600MHz Multiplexing Amplifiers

Absolute Maximum Ratings (T_A = 25°C)

Values beyond absolute maximum ratings can cause the device to be prematurely damaged. Absolute maximum ratings are stress ratings only and functional device operation is not implied.

Supply Voltage (V_{S+} to V_{S-}) 11V
 Input Voltage V_{S-} - 0.3V, V_{S+} +0.3V

Storage Temperature Range -65°C to +150°C
 Ambient Operating Temperature -40°C to +85°C
 Operating Junction Temperature 125°C
 Power Dissipation See Curves

Important Note:

All parameters having Min/Max specifications are guaranteed. Typ values are for information purposes only. Unless otherwise noted, all tests are at the specified temperature and are pulsed tests, therefore: T_J = T_C = T_A.

Specifications

V_S = +5V, V_{S-} = -5V, GND = 0V, T_A = 25°C, Input Video = 1V_{P-P} & R_L = 150Ω to GND, unless otherwise specified.

Parameter	Description	Conditions	Min	Typ	Max	Unit
General						
I _S	Supply Current (per channel)	No load, V _{IN} = 0V		16	18	mA
BW	-3dB Bandwidth	A _V = 1 (EL4344C)		600		MHz
		A _V = 2 (EL4348C)		500		MHz
FBW	0.1dB Bandwidth	A _V = 1 (EL4344C)		100		MHz
		A _V = 2 (EL4348C)		80		MHz
SR	Slew Rate	25% to 75%, R _L = 150Ω, A _V = 2 (EL4344C)		1200		V/μs
		25% to 75%, R _L = 150Ω, A _V = 2 (EL4348C)		1400		V/μs
t _{sw}	Switching Time	10% to 90%		2		ns
V _{OP}	Positive Output Swing		3.3	3.5		V
V _{ON}	Negative Output Swing		-3.2	-3.5		V
I _{OUT}	Output Current	R _L = 10Ω to GND	80	100		mA
dG	Differential Gain Error	Standard NTSC test, A _V = 2, R _L = 150Ω		0.07		%
dP	Differential Phase Error	Standard NTSC test, A _V = 2, R _L = 150Ω		0.01		°
V _{IN}	Input Voltage (video inputs)		-2.8		2.3	V
V _{OS}	Offset Voltage		-10		10	mV
e _n	Voltage Noise			17		nV/√Hz
THD	Total Harmonic Distortion	V _{OUT} = 2V _{P-P} , R _L = 150Ω, f = 200MHz		-70		dB
t _s	0.1% Settling Time	Step = 2V		6		ns
OS	Overshoot	Step = 2V		0.1	0.6	V
PSRR	Power Supply Rejection Ratio		50			dB
ISO	Channel Isolation	F = 30MHz		90		dB
V _{GLITCH}	Switching Glitch			70	120	mV
I _{SDIS}	Disable Supply Current			20		μA
A _V	Voltage Gain	EL4344C		1		
		EL4348C		2		
Control						
V _H	Logic Input High Voltage		2.0			V
V _L	Logic Input Low Voltage				0.8	V

EL4344C/EL4348C - Preliminary

600MHz Multiplexing Amplifiers

EL4344C/EL4348C - Preliminary

Block Diagram

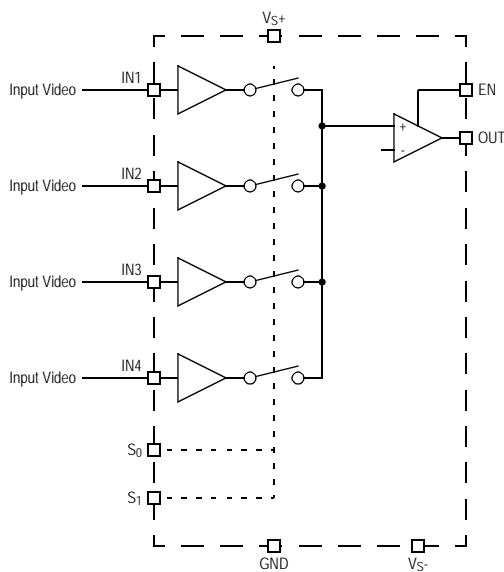

Three channels - A, B & C

Input Selector Truth Table

Inputs			State
EN	S1	S0	
1	0	0	IN1 Selected
1	0	1	IN2 Selected
1	1	0	IN3 Selected
1	1	1	IN4 Selected
0	X	X	Standby - Powered Down

EL4344C/EL4348C - Preliminary

600MHz Multiplexing Amplifiers

Pin Descriptions

Pin Number	Pin Name	Pin Type	Pin Description
1	S0	Logic Input	LSB for input selection
2	IN4A	High Frequency Signal	Input #4 for channel A
3	S1	Logic Input	MSB for input selection
4	IN1B	High Frequency Signal	Input #1 for channel B
5	GND	Power	Ground
6	IN2B	High Frequency Signal	Input #2 for channel B
7	VS+	Power	Positive power
8	IN3B	High Frequency Signal	Input #3 for channel B
9	VS-	Power	Negative power
10	IN4B	High Frequency Signal	Input #4 for channel B
11	GND	Power	Ground
12	IN1C	High Frequency Signal	Input #1 for channel C
13	EN	Logic Input	Logic high to enable
14	IN2C	High Frequency Signal	Input #2 for channel C
15	GND	Power	Ground
16	IN3C	High Frequency Signal	Input #3 for channel C
17	GND	Power	Ground
18	IN4C	High Frequency Signal	Input #4 for channel C
19	VS-	Power	Negative power
20	OUTC	High Frequency Signal	Output for channel C
21	OUTB	High Frequency Signal	Output for channel B
22	OUTA	High Frequency Signal	Output for channel A
23	VS+	Power	Positive power
24	IN1A	High Frequency Signal	Input #1 for channel A
25	GND	Power	Ground
26	IN2A	High Frequency Signal	Input #2 for channel A
27	GND	Power	Ground
28	IN3A	High Frequency Signal	Input #3 for channel A

EL4344C/EL4348C - Preliminary

600MHz Multiplexing Amplifiers

General Disclaimer

Specifications contained in this data sheet are in effect as of the publication date shown. Elantec, Inc. reserves the right to make changes in the circuitry or specifications contained herein at any time without notice. Elantec, Inc. assumes no responsibility for the use of any circuits described herein and makes no representations that they are free from patent infringement.

WARNING - Life Support Policy

Elantec, Inc. products are not authorized for and should not be used within Life Support Systems without the specific written consent of Elantec, Inc. Life Support systems are equipment intended to support or sustain life and whose failure to perform when properly used in accordance with instructions provided can be reasonably expected to result in significant personal injury or death. Users contemplating application of Elantec, Inc. Products in Life Support Systems are requested to contact Elantec, Inc. factory headquarters to establish suitable terms & conditions for these applications. Elantec, Inc.'s warranty is limited to replacement of defective components and does not cover injury to persons or property or other consequential damages.

Elantec Semiconductor, Inc.

675 Trade Zone Blvd.
Milpitas, CA 95035
Telephone: (408) 945-1323
(888) ELANTEC
Fax: (408) 945-9305
European Office: +44-118-977-6020
Japan Technical Center: +81-45-682-5820