

# EN27LV020 / EN27LV020B 2Megabit Low Voltage EPROM (256K x 8)

## FEATURES

- Read Access Time:  
-90ns, -120ns, -150ns, -200ns
- Single +3.3V Power Supply  
-Regulated power supply 3.0V - 3.6V (EN27LV020)  
-Unregulated power supply 2.7V - 3.6V (EN27LV020B for battery operated systems)
- Programming Voltage +12.75V
- QuikRite™ Programming Algorithm
- Typical programming time 20μs
- Low Power CMOS Operation
- 1μA Standby (Typical)
- 15mA Operation (Max.)
- CMOS- and TTL-Compatible I/O
- High-Reliability CMOS Technology
- Latch-Up Immunity to 100mA from -1V to  $V_{CC} + 1V$
- Two-Line Control ( $\overline{OE}$  &  $\overline{CE}$ )
- Standard Product Identification Code
- JEDEC Standard Pinout
  - 32-pin PDIP
  - 32-pin PLCC
  - 32-pin TSOP (Type 1)
- Commercial and Industrial Temperature Ranges

## GENERAL DESCRIPTION

The EN27LV020 / EN27LV020B is a low-voltage, low-power 2-Megabit, 3.3V one-time-programmable (OTP) read-only memory (EPROM). Organized into 256K words with 8 bits per word, it features QuikRite™ single-address location programming, typically at 20μs per byte. Any byte can be accessed in less than 90ns. The EN27LV020 / EN27LV020B has separate Output Enable ( $\overline{OE}$ ) and Chip Enable ( $\overline{CE}$ ) controls which eliminate bus contention issues. The EN27LV020 has a  $V_{CC}$  tolerance range of 3.0V to 3.6 V, making it suitable for use in systems that have regulated power supplies. The EN27LV020B has a  $V_{CC}$  tolerance range of 2.7 V to 3.6V, making it an ideal device for battery operated systems.

FIGURE 1. PDIP

Pin Name	Function
A0-A17	Addresses
DQ0-DQ7	Outputs
$\overline{CE}$	Chip Enable
$\overline{OE}$	Output Enable
PGM	Program Strobe

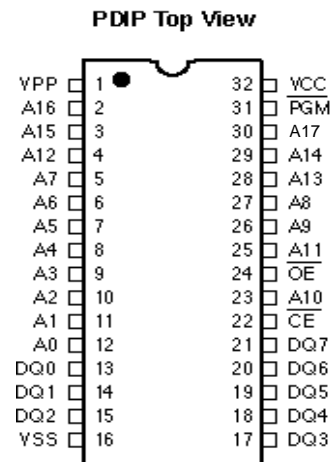

FIGURE 2. TSOP

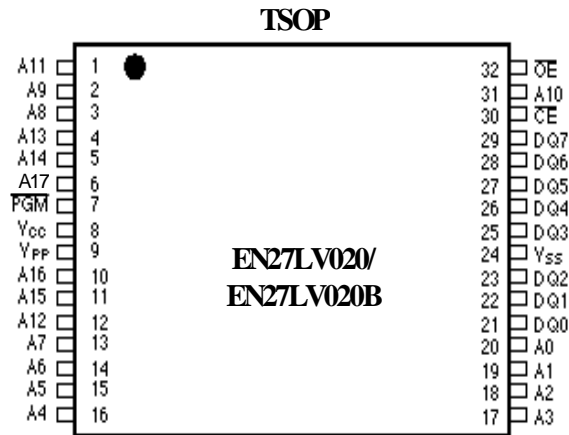
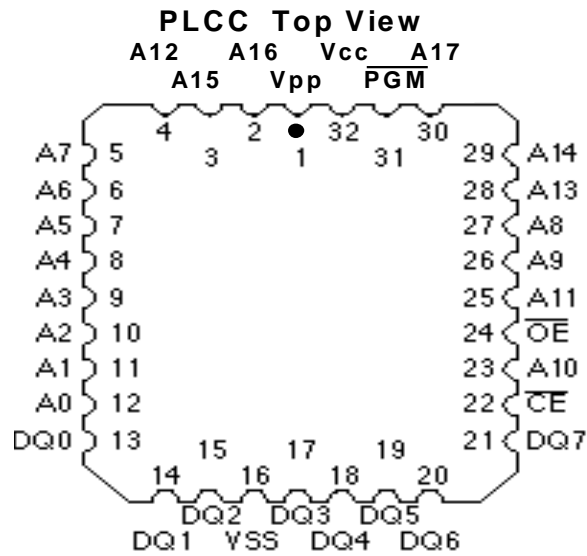
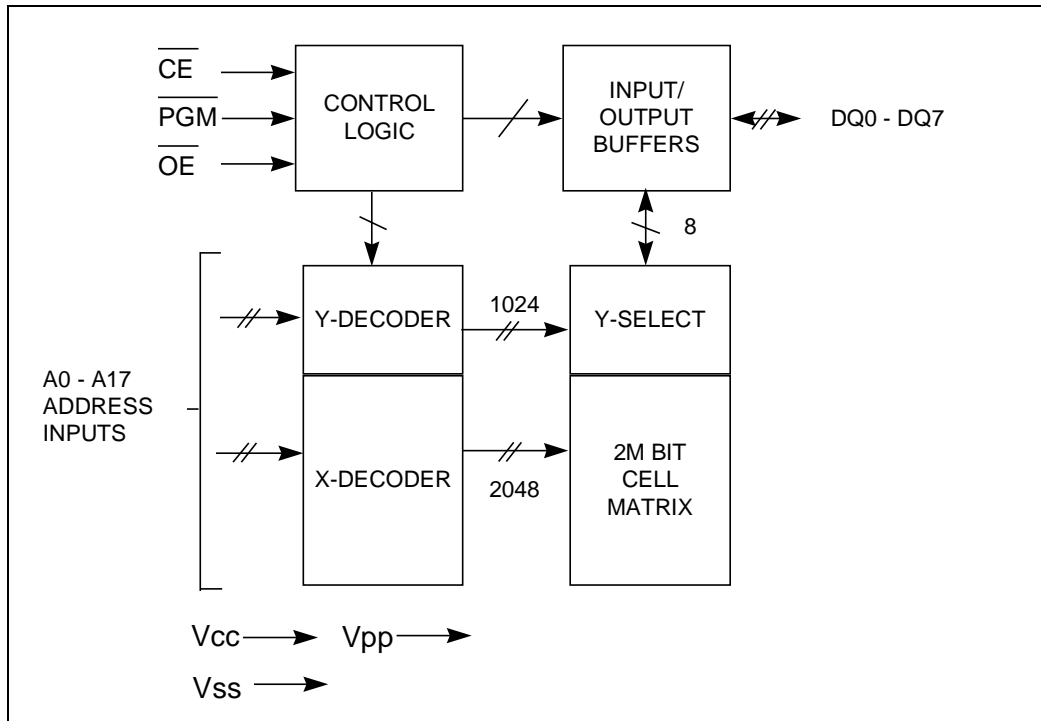

FIGURE 3. PLCC



**FIGURE 4. BLOCK DIAGRAM**

## FUNCTIONAL DESCRIPTION

### THE QUIKRITE™ PROGRAMMING OF THE EN27LV020 / EN27LV020B

When the EN27LV020 / EN27LV020B is delivered, the chip has all 2M bits in the “ONE”, or HIGH state. “ZEROs” are loaded into the EN27LV020 / EN27LV020B through the procedure of programming.

The programming mode is entered when  $12.75 \pm 0.25V$  is applied to the  $V_{PP}$  pin,  $\overline{OE}$  is at  $V_{IH}$ , and  $\overline{CE}$  and  $\overline{PGM}$  are at  $V_{IL}$ . For programming, the data to be programmed is applied with 8 bits in parallel to the data pins.

The QUIKRITE™ programming flowchart in Figure 5 shows Eon’s interactive programming algorithm. The interactive algorithm reduces programming time by using  $20 \mu s$  to  $100 \mu s$  programming pulses and giving each address only as many pulses as is necessary in order to reliably program the data. After each pulse is applied to a given address, the data in that address is verified. If the data is not verified, additional pulses are given until it is verified or until the maximum number of pulses is reached. This process is repeated while sequencing through each address of the EN27LV020 / EN27LV020B. This part of the programming algorithm is done at  $V_{CC} = 6.25V$  to assure that each EPROM bit is programmed to a sufficiently high threshold voltage. This ensures that all bits have sufficient margin. After the final address is completed, the entire EPROM memory is read at  $V_{CC} = V_{PP} = 5.25 \pm 0.25V$  to verify the entire memory. EN27LV020 / EN27LV020B can be programmed using the same programming algorithm as the 5V Read EPROM EN27C020.



## PROGRAM INHIBIT MODE

Programming of multiple EN27LV020 / EN27LV020B in parallel with different data is also easily accomplished by using the Program Inhibit Mode. Except for  $\overline{CE}$ , all like inputs of the parallel EN27LV020 / EN27LV020B may be common. A TTL low-level program pulse applied to an EN27LV020 / EN27LV020B  $\overline{CE}$  input with  $V_{PP} = 12.75 \pm 0.25V$ , PGM LOW, and  $\overline{OE}$  HIGH will program that EN27LV020 / EN27LV020B. A high-level  $\overline{CE}$  input inhibits the other EN27LV020 / EN27LV020B from being programmed.

## PROGRAM VERIFY MODE

Verification should be performed on the programmed bits to determine that they were correctly programmed. The verification should be performed with  $\overline{OE}$  and  $\overline{CE}$  at  $V_{IL}$ , PGM at  $V_{IH}$ , and  $V_{PP}$  at its programming voltage.

## AUTO PRODUCT IDENTIFICATION

The Auto Product Identification mode allows the reading out of a binary code from an EPROM that will identify its manufacturer and type. This mode is intended for use by programming equipment for the purpose of automatically matching the device to be programmed with its corresponding programming algorithm. This mode is functional in the  $25^{\circ}C \pm 5^{\circ}C$  ambient temperature range that is required when programming the EN27LV020 / EN27LV020B.

To activate this mode, the programming equipment must force  $12.0V \pm 0.5V$  on address line A9 of the EN27LV020 / EN27LV020B. Two identifier bytes may then be sequenced from the device outputs by toggling address line A0 from  $V_{IL}$  to  $V_{IH}$ , when  $A1 = V_{IH}$ . All other address lines must be held at  $V_{IL}$  during Auto Product Identification mode.

Byte 0 ( $A0 = V_{IL}$ ) represents the manufacturer code, and byte 1 ( $A0 = V_{IH}$ ), the device code. For the EN27LV020 / EN27LV020B these two identifier bytes are given in the Mode Select Table. All identifiers for manufacturer and device codes will possess odd parity, with the MSB (DQ7) defined as the parity bit. When  $A1 = V_{IL}$ , the EN27LV020 / EN27LV020B will read out the binary code of 7F, continuation code, to signify the unavailability of manufacturer ID codes.



## READ MODE

The EN27LV020 / EN27LV020B has two control functions, both of which must be logically satisfied in order to obtain data at the outputs. Chip Enable ( $\overline{CE}$ ) is the power control and should be used for device selection. Output Enable ( $\overline{OE}$ ) is the output control and should be used to gate data to the output pins, independent of device selection. Assuming that addresses are stable, address access time ( $t_{ACC}$ ) is equal to the delay from  $\overline{CE}$  to output ( $t_{CE}$ ). Data is available at the outputs ( $t_{OE}$ ) after the falling edge of  $\overline{OE}$ , assuming the  $\overline{CE}$  has been LOW and addresses have been stable for at least  $t_{ACC} - t_{OE}$ .

## STANDBY MODE

The EN27LV020 / EN27LV020B has CMOS standby mode which reduces the maximum  $V_{CC}$  current to  $10\mu A$ . It is placed in CMOS standby when  $\overline{CE}$  is at  $V_{CC} \pm 0.3 V$ . The EN27LV020 / EN27LV020B also has a TTL-standby mode which reduces the maximum  $V_{CC}$  current to 0.6 mA. It is placed in TTL-standby when  $\overline{CE}$  is at  $V_{IH}$ . When in standby mode, the outputs are in a high-impedance state, independent of the OE input.

## TWO-LINE OUTPUT CONTROL FUNCTION

To accommodate multiple memory connections, a two-line control function is provided to allow for:

1. Low memory power dissipation,
2. Assurance that output bus contention will not occur.

It is recommended that  $\overline{CE}$  be decoded and used as the primary device-selection function, while  $\overline{OE}$  be made a common connection to all devices in the array and connected to the READ line from the system control bus. This assures that all deselected memory devices are in their low-power standby mode and that the output pins are only active when data is desired from a particular memory device.

## SYSTEM CONSIDERATIONS

During the switch between active and standby conditions, transient current peaks are produced on the rising and falling edges of Chip Enable. The magnitude of these transient current peaks is dependent on the output capacitance loading of the device. At a minimum, a  $0.1\mu F$  ceramic capacitor (high frequency, low inherent inductance) should be used on each device between  $V_{CC}$  and  $V_{SS}$  to minimize transient effects. In addition, to overcome the voltage drop caused by the inductive effects of the printed circuit board traces on EPROM arrays, a  $4.7\mu F$  bulk electrolytic capacitor should be used between  $V_{CC}$  and  $V_{SS}$  for each eight devices. The location of the capacitor should be close to where the power supply is connected to the array.

**MODE SELECT TABLE**

Mode	$\overline{\text{CE}}$	$\overline{\text{OE}}$	$\overline{\text{PGM}}$	A0	A1	A9	V <sub>PP</sub>	Output
Read	V <sub>IL</sub>	V <sub>IL</sub>	X <sup>(2)</sup>	X	X	X	V <sub>CC</sub>	D <sub>OUT</sub>
Output Disable	V <sub>IL</sub>	V <sub>IH</sub>	X	X	X	X	V <sub>CC</sub>	High Z
Standby (TTL)	V <sub>IH</sub>	X	X	X	X	X	V <sub>CC</sub>	High Z
Standby (CMOS)	V <sub>CC</sub> ± 0.3V	X	X	X	X	X	V <sub>CC</sub>	High Z
Program <sup>(4)</sup>	V <sub>IL</sub>	V <sub>IH</sub>	V <sub>IL</sub>	X	X	X	V <sub>PP</sub>	D <sub>IN</sub>
Program Verify	V <sub>IL</sub>	V <sub>IL</sub>	V <sub>IH</sub>	X	X	X	V <sub>PP</sub>	D <sub>OUT</sub>
Program Inhibit	V <sub>IH</sub>	X	X	X	X	X	V <sub>PP</sub>	High Z
Manufacturer Code <sup>(3)</sup>	V <sub>IL</sub>	V <sub>IL</sub>	X	V <sub>IL</sub>	V <sub>IH</sub>	V <sub>H</sub> <sup>(1)</sup>	V <sub>CC</sub>	1C
Device Code <sup>(3)</sup>	V <sub>IL</sub>	V <sub>IL</sub>	X	V <sub>IH</sub>	V <sub>IH</sub>	V <sub>H</sub> <sup>(1)</sup>	V <sub>CC</sub>	02

**NOTES:**

- 1) V<sub>H</sub> = 12.0V ± 0.5V
- 2) X = Either V<sub>IH</sub> or V<sub>IL</sub>
- 3) For Manufacturer Code and Device Code, A1 = V<sub>IH</sub>  
When A1 = V<sub>IL</sub>, both codes will read 7F
- 4) See DC Programming Characteristics for V<sub>PP</sub> voltage during programming

**EON'S STANDARD PRODUCT IDENTIFICATION CODE**

Code	Pins										Hex Data
	A0	A1	DQ7	DQ6	DQ5	DQ4	DQ3	DQ2	DQ1	DQ0	
Manufacturer	0	1	0	0	0	1	1	1	0	0	1C
Device Type	1	1	0	0	0	0	0	0	1	0	02
Continuation	0	0	0	1	1	1	1	1	1	1	7F
	1	0	0	1	1	1	1	1	1	1	7F

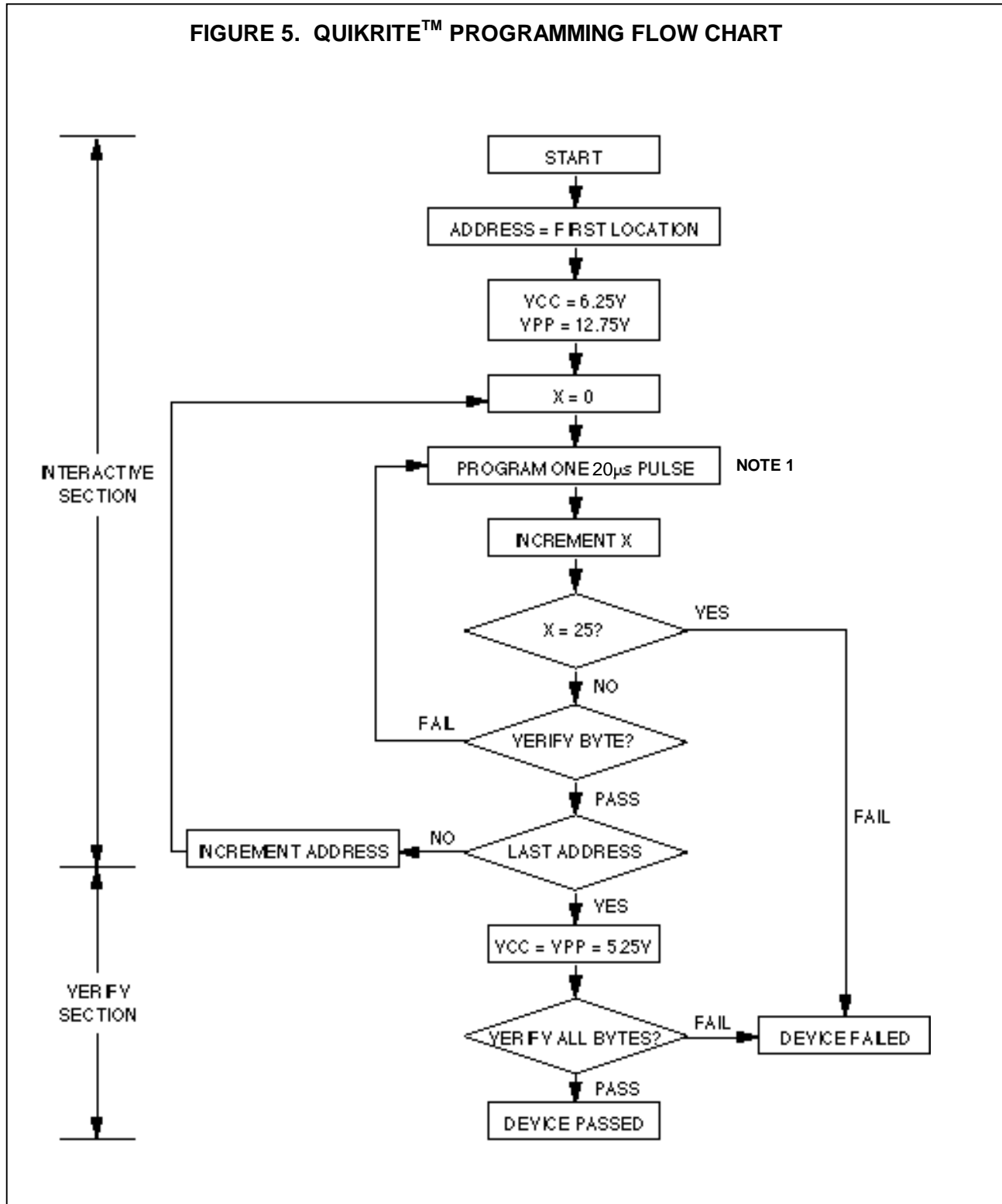
**FIGURE 5. QUIKRITE™ PROGRAMMING FLOW CHART**

**NOTE 1:** Either 100µs or 20µs pulse.

**ABSOLUTE MAXIMUM RATINGS**

<b>Storage Temperature</b>	-65 ° C to +125 ° C
<b>Ambient Temperature</b> with Power Applied	-40 ° C to +85 ° C
<b>Voltage with Respect to V<sub>ss</sub></b>	
All pins except A9, V <sub>PP</sub> , V <sub>CC</sub>	-0.6V to V <sub>CC</sub> + 0.5V
A9, V <sub>PP</sub>	-0.6V to +13.5V
V <sub>CC</sub>	-0.6V to +7.0V

**OPERATING RANGES**

<b>Commercial (C)</b>	
Case Temperature(T <sub>c</sub> )	0 ° C to +70 ° C
<b>Industrial (I)</b>	
Case Temperature(T <sub>c</sub> )	-40 ° C to +85 ° C
<b>Supply READ Voltages</b>	+3.0V to +3.6V
(for battery operated systems)	+2.7V to +3.6V
(Functionality is guaranteed between these limits)	

Stresses above those shown above may cause permanent damage to the device. This is a stress rating only and operation above these specifications for extended periods may affect device reliability. Operation outside the "**OPERATING RANGES**" shown above voids any and all warranty provisions.

**DC CHARACTERISTICS FOR READ OPERATION**

Symbol	Parameter	Min.	Max.	Unit	Conditions
V <sub>OH</sub>	Output High Voltage	2.4		V	I <sub>OH</sub> = -2.0mA
V <sub>OL</sub>	Output Low Voltage		0.45	V	I <sub>OL</sub> = 2.0mA
V <sub>IH</sub>	Input High Voltage	2.0	V <sub>CC</sub> +0.5	V	
V <sub>IL</sub>	Input Low Voltage	-0.3	0.8	V	
I <sub>LI</sub>	Input Leakage Current	-5	5	μA	V <sub>IN</sub> = 0 to 3.6V
I <sub>LO</sub>	Output Leakage Current	-10	10	μA	V <sub>OUT</sub> = 0 to 3.6V
I <sub>CC3</sub>	V <sub>CC</sub> Power -Down Current		10	μA	CE = V <sub>CC</sub> ± 0.3V
I <sub>CC2</sub>	V <sub>CC</sub> Standby Current		0.6	mA	CE = V <sub>IH</sub>
I <sub>CC1</sub>	V <sub>CC</sub> Active Current		15	mA	CE = V <sub>IL</sub> , f=5MHz, I <sub>OUT</sub> = 0mA
I <sub>PP1</sub>	V <sub>PP</sub> Supply Current Read		100	μA	CE = OE = V <sub>IL</sub> , V <sub>PP</sub> = 3.6V

**CAPACITANCE**

Symbol	Parameter	Typ.	Max.	Unit	Conditions
C <sub>IN</sub>	Input Capacitance	8	12	pF	V <sub>IN</sub> = 0V
C <sub>OUT</sub>	Output Capacitance	8	12	pF	V <sub>OUT</sub> = 0V
C <sub>VPP</sub>	V <sub>PP</sub> Capacitance	18	25	pF	V <sub>PP</sub> = 0V



**AC CHARACTERISTICS FOR READ OPERATION**

Symbol	Parameter	EN27LV020 / EN27LV020B	-90		-120		-150		-200		Unit
		Condition	Min	Max	Min	Max	Min	Max	Min	Max	
tACC (3)	Address to Output Delay	$\overline{CE} = \overline{OE} = V_{IL}$	90		120		150		200		ns
tCE (2)	$\overline{CE}$ to Output Delay	$\overline{OE} = V_{IL}$	90		120		150		200		ns
tOE (2, 3)	$\overline{OE}$ to Output Delay	$\overline{OE} = V_{IL}$	45		45		50		50		ns
tDF (4, 5)	$\overline{OE}$ or $\overline{CE}$ High to Output Float, whichever occurred first		40		40		40		40		ns
tOH	Output Hold from Address, $\overline{CE}$ or $\overline{OE}$ , whichever occurred first		0		0		0		0		ns

Note: Please contact Marketing Department for other speed requirements.

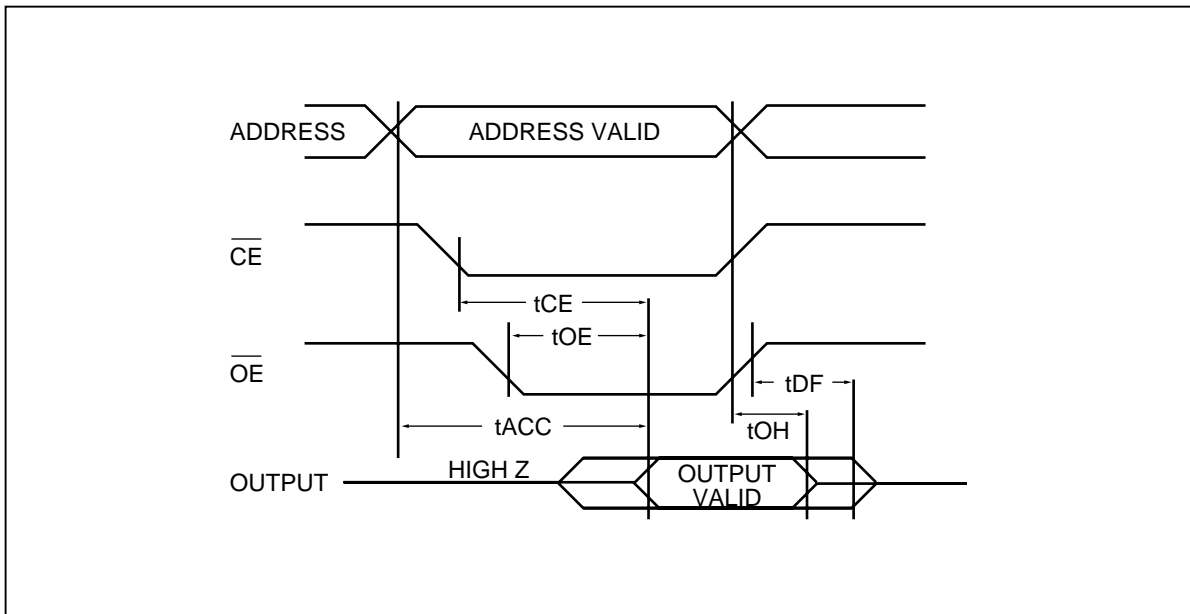
**FIGURE 6. AC WAVEFORMS FOR READ OPERATION**

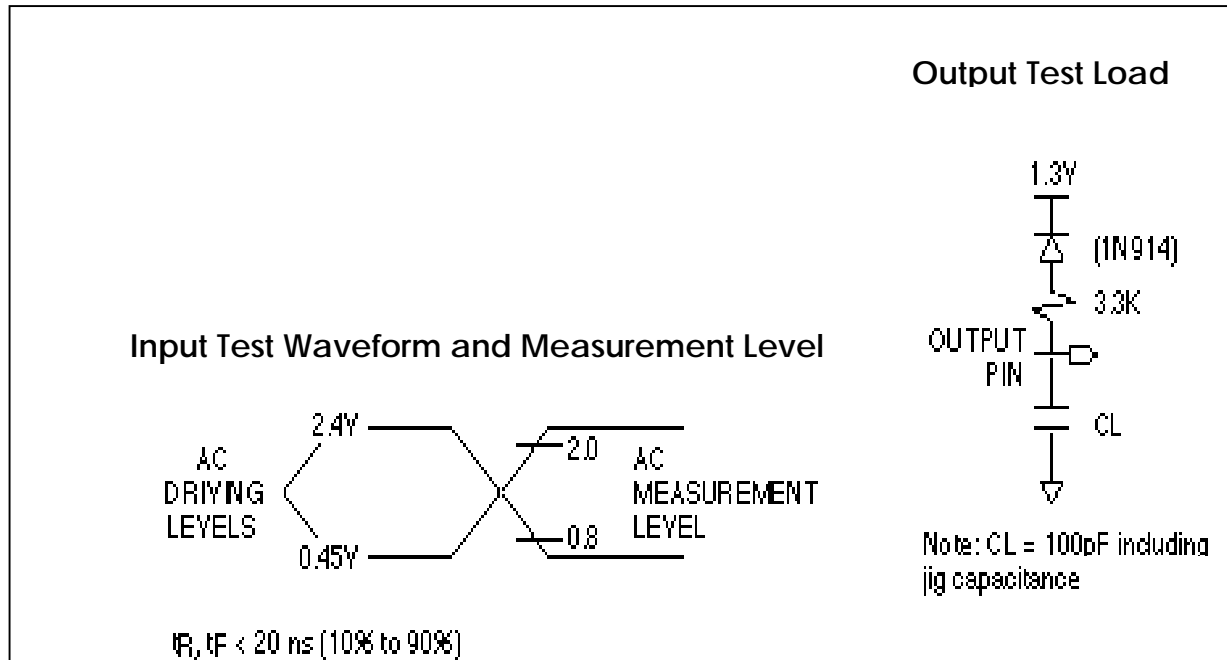
**FIGURE 7: TEST WAVEFORMS AND MEASUREMENTS**

### DC PROGRAMMING CHARACTERISTICS

Symbol	Parameter	Test Conditions	Limits		Units
			Min.	Max	
$I_{LI}$	Input Load Current	$V_{IN} = V_{IL}, V_{IH}$		5.0	$\mu\text{A}$
$V_{IL}$	Input Low Level		-0.5	0.8	V
$V_{IH}$	Input High Level		$0.7 V_{CC}$	$V_{CC} + 0.5$	V
$V_{OL}$	Output Low Voltage	$I_{OL} = 2.0 \text{ mA}$		0.45	V
$V_{OH}$	Output High Voltage	$I_{OH} = -400 \mu\text{A}$	2.4		V
$I_{CCP}$	$V_{CC}$ Supply Current			40	mA
$I_{PP2}$	$V_{PP}$ Supply Current	$\overline{CE} = \overline{PGM} = V_{IL}$		10	mA
$V_{ID}$	A9 Product Identification Voltage		11.5	12.5	V
$V_{CC}$	Quikrite Supply Voltage		6.0	6.5	V
$V_{PP}$	Quikrite Programming Voltage		12.5	13.0	V

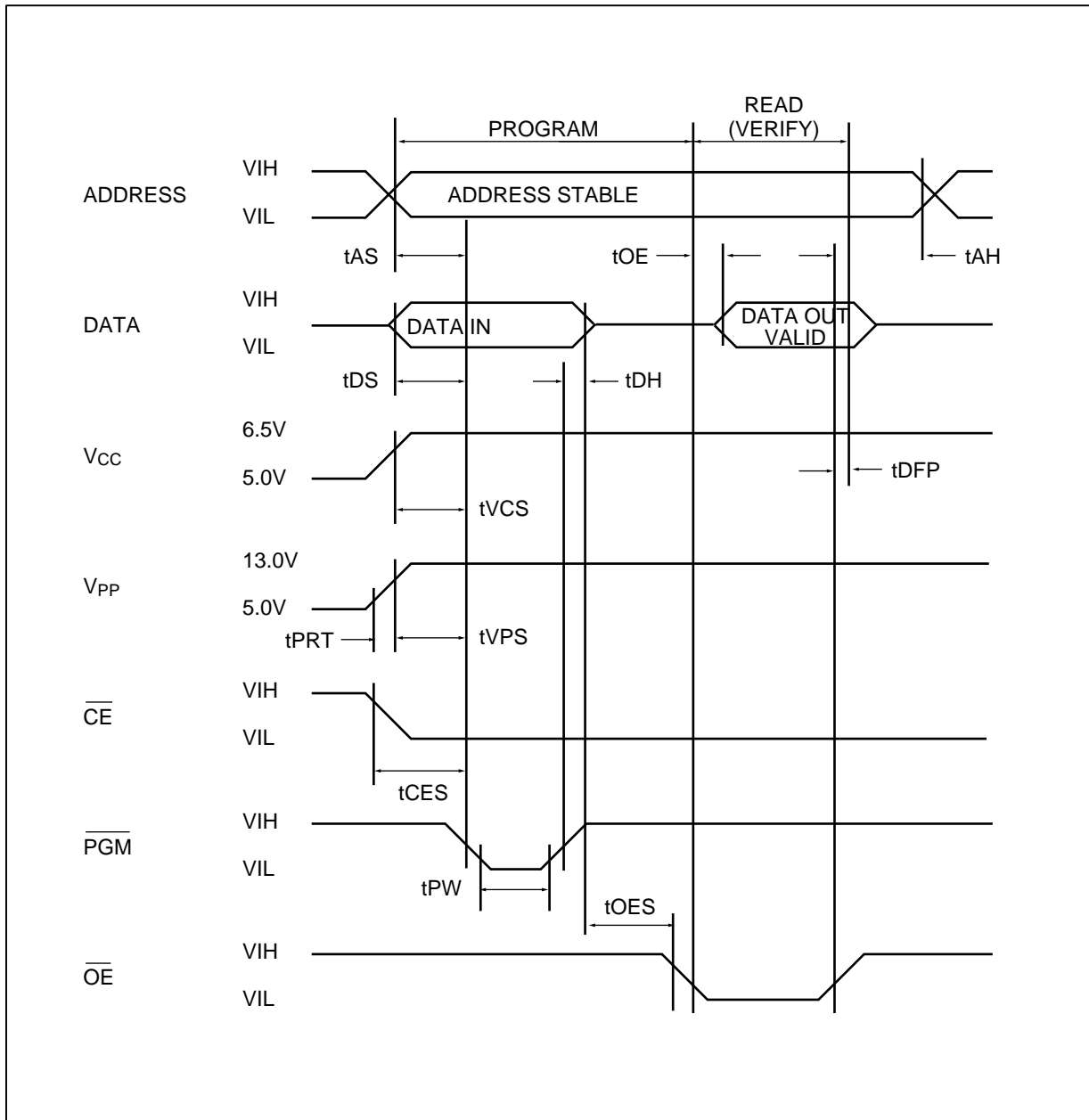
**FIGURE 8. PROGRAMMING WAVEFORMS**

**SWITCHING PROGRAMMING CHARACTERISTICS** $(T_A = +25^\circ\text{C} \pm 5^\circ\text{C})$ 

PARAMETER SYMBOL	PARAMETER DESCRIPTION	Min.	Max	Units
$t_{AS}$	Address Setup Time	2		$\mu\text{s}$
$t_{OES}$	$\overline{\text{OE}}$ Setup Time	2		$\mu\text{s}$
$t_{DS}$	Data Setup Time	2		$\mu\text{s}$
$t_{AH}$	Address Hold Time	0		$\mu\text{s}$
$t_{DH}$	Data Hold Time	2		$\mu\text{s}$
$t_{DFP}$	Output Enable to Output Float Delay	0	130	ns
$t_{VPS}$	$V_{PP}$ Setup Time	2		$\mu\text{s}$
$t_{PW}$	PGM Program Pulse Width	20	105	$\mu\text{s}$
$t_{VCS}$	$V_{CC}$ Setup Time	2		$\mu\text{s}$
$t_{CES}$	$\overline{\text{CE}}$ Setup Time	2		$\mu\text{s}$
$t_{OE}$	Data Valid from $\overline{\text{OE}}$		150	ns

**ORDERING INFORMATION**

EN27LV020 / EN27LV020B

90 P I

**TEMPERATURE RANGE**(Blank) = Commercial (  $0^\circ\text{C}$  to  $+70^\circ\text{C}$  )I = Industrial (  $-40^\circ\text{C}$  to  $+85^\circ\text{C}$  )**PACKAGE**

P = 32 Plastic DIP

J = 32 Plastic PLCC

T = 32 Plastic TSOP

**SPEED**

90 = 90ns

120 = 120ns

150 = 150ns

200 = 200ns

**BASE PART NUMBER**

EN = EON Silicon Devices

27 = EPROM

LV = Low Voltage CMOS

020 = 256K x 8 3.0V to 3.6V  $V_{CC}$ 

Tolerance



020B = 256K x 8 2.7V to 3.6V Vcc

Tolerance