

XI'AN IR-PERI



Company PRELIMINARY

GA150TD120K

“HALF-BRODGE” IGBT DOUBLE INT-A -PAK

Short Circuit Rated
Ultra-Fast™ Speed IGBT

Features

- Generation 5 IGBT NPT technology
- UltraFast optimized high operating frequencies 8-40 kHz in hard switching, >200 kHz in resonant mode.
- Very low conduction and switching losses
- HEXFRED™ antiparallel diodes with ultra-soft recovery
- Industry standard package
- UL recognition pending
- Short circuit rated 10 μs

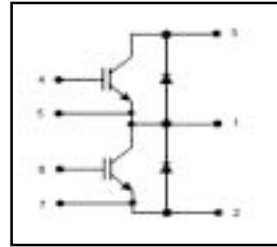

$V_{CES}=1200V$
 $V_{CE(on) typ.}=2.5V$
@ $V_{GE}=15V, I_c=150A$

Benefits

- Increased operating efficiency
- Direct mounting to heatsink
- Performance optimized for power conversion: UPS, SMPS, Welding, Mortor Control
- Lower EMI, requiries less snubbing

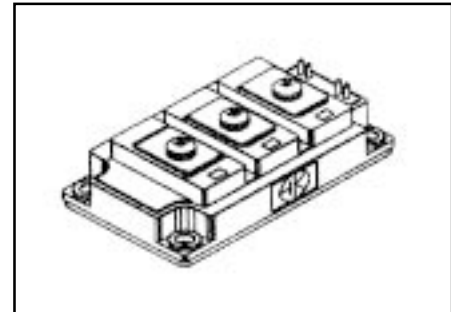

Absolute Maximum Ratings

	Parameter	Max.	Units
V_{CES}	Collector-to- Emitter Voltage	1200	V
$I_c @ T_c=25^{\circ}C$	Continuous Collector Current	210	A
$I_c @ T_c=85^{\circ}C$	Continuous Collector Current	150	
I_{CM}	Pulsed collector Current	300	
I_{LM}	Peak switching Current	300	
I_{FM}	Peak Diode Forward Current	300	
V_{GE}	Gate- to- Emitter Voltage	±20	V
V_{ISOL}	RMS Isolation Voltage, Any Terminal To Case, t=1 min	2500	
$P_D @ T_c=25^{\circ}C$	Maximum Power Dissipation	1250	W
$P_D @ T_c=85^{\circ}C$	Maximum Power Dissipation	650	
T_J	Operating Junction Temperature Range	-40 to +150	°C
T_{STG}	Storage Temperature Range	-40 to +125	

Termal / Mechanical Characteristics

	Parameter	Typ.	Max.	Units
$R_{\theta JC}$	Termal Resistance, Junction-to- Case- IGBT	-	0.10	°C/W
$R_{\theta JC}$	Termal Resistance, Junction-to- Case- Diode	-	0.15	
$R_{\theta CS}$	Termal Resistance, Csar-to- Sink- Module	0.1	-	
	Mouting Torque, Case-to-Heatsink	-	4.0	N.m
	Mouting Torque, Case-to-Terminal 1,2 & 3	-	3.0	
	Weight of Module	400	-	g

GA150TD120K



Electrical Characteristics @ T_J=25°C(unless otherwise specified)

	Parameter	Min.	Typ.	Max.	Units	Conditions
V _{(BR)CES}	Collector-to-Emitter Breakdown Voltage	1200	—	—	V	V _{GE} =0V, I _c =1mA
V _{CE(ON)}	Collector-to-Emitter Voltage	—	2.5	—		V _{GE} =15V, I _c =150A
		—	2.7	—		V _{GE} =15V, I _c =150A, T _J =125°C
V _{GE(th)}	Gate Threshold Voltage	4.5	—	5.5		I _c =1.75mA
DV _{GE(th)DTJ}	Temperature Coeff. of Threshold Voltage	—	-11	—	mV/°C	V _{CE} =V _{GE} , I _c =1.75mA
g _{fe}	Forward Transconductance	—	201	—	S	V _{CE} =25V, I _c =150A
I _{CES}	Collector - to - Emitter Leaking Current	—	—	2.0	mA	V _{GE} =0V, V _{CE} =1200V
		—	—	20		V _{GE} =0V, V _{CE} =1200V, T _J =125°C
V _{FM}	Diode Forward Voltage - Maximum	—	2.1	2.5	V	I _F =150A, V _{GE} =0V
		—	1.9	—		I _F =150A, V _{GE} =0V, T _J =125°C
I _{GES}	Gate - to - Emitter Leakage Current	—	—	500	nA	V _{GE} =±20V

Dynamic Characteristics - T_J=125°C (unless otherwise specified)

	Parameter	Min.	Typ.	Max.	Units	Conditions
Q _g	Total gate charge (turn - on)	—	1440	1710	nC	V _{CC} =400V V _{GE} =15V I _c =171A T _J =25°C
Q _{ge}	Gate - Emitter charge (turn - on)	—	192	288		
Q _{gc}	Gate - Collector charge (turn - on)	—	377	565		
T _{d(on)}	Turn - On Delay Time	—	380	—	nS	R _{G1} =15Ω , R _{G2} = 0Ω I _c = 150A V _{CC} =720V V _{GE} =±15V
t _r	Rise Time	—	208	—		
T _{d(off)}	Turn - Off Delay Time	—	412	—		
t _f	Fall Time	—	100	—		
E _{on}	Turn - On Switching Energy	—	34	—	mJ	
E _{off(1)}	Total Switching Energy	—	18	—		
E _{ts(1)}	Turn - On Switching Energy	—	52	70		
C _{ies}	Input Capacitance	—	25643	—	pF	V _{GE} = 0V V _{CC} = 30V f=1MHZ
C _{oes}	Output Capacitance	—	1139	—		
C _{res}	Reverse Transfer Capacitance	—	222	—		
t _{rr}	Diode Reverse Recovery Time	—	186	—	nS	I _c = 150A
I _{rr}	Diode Peak Reverse Current	—	131	—	A	R _{G1} =15Ω
Q _{rr}	Diode Recovery Charge	—	12383	—	nC	R _{G2} =0Ω
di(rec)M/dt	Diode Peak Rate of Fall of Recovery During t _b	—	2520	—	A/μs	V _{CC} =720V di/dt=1294A/μs
T _{sc}	Short circuit withstand time	10	—	—	μs	V _{CC} =720V, V _{GE} =±15V Min. R _{G1} =15Ω, V _{CEP} =1100V