

# GL3276A

## Description

The GL3276A is a bipolar analog ICs specifically developed for use in infrared remote control system receiving preamplifiers. Capable of accepting a photodiode directly, these ICs house a high gain initial amplifier, a limiter, a band-pass filter, a detection circuit and a waveform shaping circuit assembled on a single chip.

## Features

- Less changes of malfunction associated with a high-frequency lighting fluorescent lamp internal trap circuit.
- The central frequency can be varied with an external resistance:  
 $f_0=30$  to  $80\text{KHz}$   
 fo rimming reduce central frequency variance.
- Few external parts.  
 Internal pull-up resistance and power filter resistance.  
 Lower-capacitance external capacitor
- Open collector output  
 Open collector output with a pull-up resistance.

## Pin configuration

(SOP)

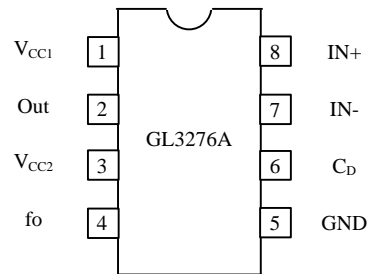

## Block Diagram

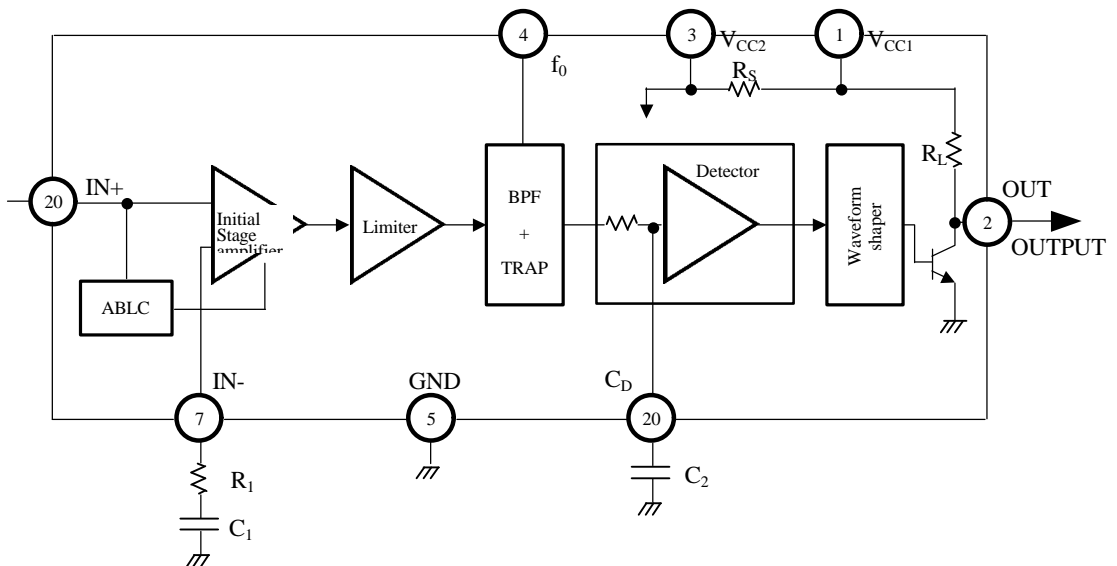

**Absolute Maximum Ratings**( $T_a=25$  ;  $\dot{E}$ )

SYMBOL	PARAMETER	VALUE	UNIT
$V_{CC}$	Supply voltage	6.0	V
$I_{OUT}$	Output Current	2.5	mA
$P_D$	Allowable power dissipation	270	mW
$T_{OPR}$	Operating temperature	- 20 to +75	$^{\circ}C$
$T_{STG}$	Storage temperature	-40 to +125	$^{\circ}C$

**Recommended Operating Condition**

SYMBOL	PARAMETER	MIN	TYP	MAX	UNIT
$V_{CC}$	Supply voltage	4.5	5.0	5.5	V
$f_{IN}$	Input frequency	30	38	80	KHz

**Electrical characteristics** ( $V_{CC} = 5.0V$ ,  $T_a = 2.5$ ;  $\dot{E}$ )

SYMBOL	PARAMETER	TEST CONDITION	MIN	TYP	MAX	UNIT	REMARK
$I_{CC}$	Supply current			1.2	2.8	mA	
$V_{IN}$	Input voltage	$I_{IN} = 0A$ $I_{IN}=-330 \mu A$	2.0 0.6	2.5 0.8	3.1 1.7	V	
$A_V$	Voltage gain	$f_{IN}=38kHz$ $V_{IN}=30 \mu V_{P-P}$	70	76	80	dB	
$F_{BW}$	BPF bandwidth	-3dB Bandwidth $V_{IN}=30 \mu V_{P-P}$	2.0	2.5	3.0	KHz	
$r_{IN}$	Input impedance	$f_{IN}=38kHz$ CW $V_{IN}=0.2 \mu V_{P-P}$	80	110	160	K $\Omega$	note 1
$t_{PW1}$	Output pulse width	$f_{IN}=38kHz$ burstwave $V_{IN}=500 \mu V_{P-P}$	440		770	$\mu S$	note 1
$t_{PW2}$		$f_{IN}=38kHz$ burstwave $V_{IN}=50mV_{P-P}$	440		770	$\mu S$	
$V_{OL}$	Low Level output voltage			0.2	0.4	V	
$V_{OH}$	Low Level output voltage		4.8	5.0		V	

**Note 1 :**  $r_{IN} = \frac{47}{(\frac{V_{IN}}{V_X})-1}$  K $\Omega$  (where  $V_{IN}$ =input level,  $V_X$ =test value)

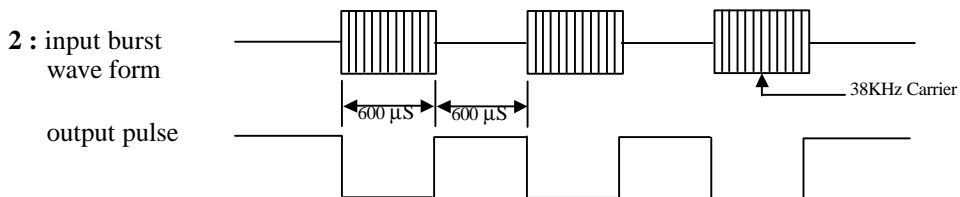

**Pin Description**

NO.	SYMBOL	PIN FUNCTION	
1	V <sub>CC1</sub>	Power input	<ul style="list-style-type: none"> <li>Apply a voltage of 5V ± 10% to pin 1. As the power is output to pin 3 through the internal power filter resistance, connect an electrolytic capacitor to pin 3.</li> </ul>
3	V <sub>CC2</sub>	Power output	
5	GND	Ground	
8	IN +	Input	<ul style="list-style-type: none"> <li>With an internal impedance of 110 KΩ (typ.) pin 8 can accept a PIN photodiode directly. An automatic bias level control (ABLC) circuit prevents the input from being saturated by external light, assuring bias level stability for the input pin.</li> </ul>
7	IN -	Initial amplifier Gain setup	<ul style="list-style-type: none"> <li>Initial amplifier differential inverted output. Its gain can be set up with an external impedance.</li> </ul>
4	f <sub>o</sub>	BPF frequency setup	<ul style="list-style-type: none"> <li>The central frequency of the band-pass filter can be varied with an external resistance. A built-in trap circuit prevents malfunctions associated with a high-frequency lighting fluorescent lamp.</li> </ul>
6	C <sub>D</sub>	Detection capacitor	<ul style="list-style-type: none"> <li>Pin to which a detection capacitor is connected.</li> </ul>
2	OUT	Output	<ul style="list-style-type: none"> <li>Open collector output with pull-up resistance. Its capability to drive a CMOS or TTL makes for easy connection with a receiving microcomputer. The GL3276A has an active low output.</li> </ul>

**Sample Application Circuits**  
**8 Pin Plastic**  
**SOP**

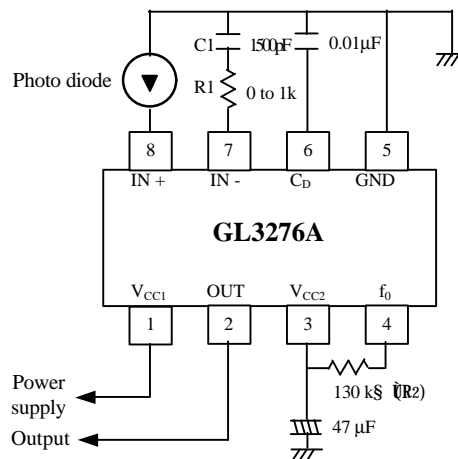

Typical Characteristics ( $T_A = 25^\circ\text{C}$ )

