





PAD	CONNECTION
1	Ground or Freq adjustment
2	Not connected
3	Ground
4	Output
5	Not connected
6	Supply

Scale 3:1

Features

-  **Supply voltages from 2.3V ~ 3.6V**
-  **Low power consumption**
-  **Miniature SM package**
-  **Excellent frequency stability**

Standard Frequencies

Frequencies in MHz	
12.80000	19.20000
13.00000	19.44000
14.40000	19.68000
15.00000	19.80000
15.36000	24.55350
16.00000	26.00000
16.36800	40.00000

Other frequencies available. Please consult our sales office.

Specifications

GTXO-92T: TCXO, no frequency adjustment

GTXO-92V: TCXO with VC frequency adjustment

Parameters	Variant		Option Codes
	T	V	
Frequency range: 8.0 ~ 44.0MHz	■	■	
Frequency stability: ±3.0ppm	□	□	K
±2.5ppm	■	■	J
±2.0ppm	□	□	H
±1.5ppm	□	□	G
Temperature range: 0 to +50°C	□	□	R
-10 to +60°C	□	□	C
-20 to +70°C	□	□	N
-30 to +75°C	■	■	S
Storage temperature range: -40 to +85°C	■	■	
Frequency vs supply voltage: ±0.2ppm, V _{DD} ±5%	■	■	
Ageing: ±1.0ppm max first year	■	■	
Supply voltage (V_{DD}): +2.3V ~ +3.6V (see note 1)	■	■	
Supply current: 1.5mA max (<20.0MHz) 2.0mA max (>=20.0MHz)	■	■	
Output waveform: Clipped sine, 0.8V p-p (see note 2)	■	■	
Test load: 10kΩ // 10pF	■	■	
Start up time: 2.5ms max	■	■	
Frequency adjustment: None ±8ppm min, +1.5 ±1.0V	■	■	
Phase noise (typ @ 20.0MHz): -54dBc/Hz @ 1Hz -86dBc/Hz @ 10Hz -135dBc/Hz @ 1kHz -151dBc/Hz @ 100kHz	■	■	
Stability 2hrs after reflow: ±1.0ppm max	■	■	
Preset frequency: ±0.5ppm / +25°C ±2°C	■	■	

■ Standard. □ Optional - Please specify required code(s) when ordering

Ordering Information

Product name + variant + option codes + frequency
 Option codes must be included to properly specify a model.
 eg: **GTXO-92V/JS 13.00MHz** ±2.5ppm -30+75°C, TCXO with VC
GTXO-92T/HN 14.40MHz ±2.0ppm -20+70°C, TCXO no VC
 Option code X (eg GTXO-92V/X) denotes a custom spec.

- ♦ 1: Will operate within specification on any supply voltage from +2.3V to +3.6V.
- ♦ 2: The output is not DC-free. A coupling capacitor (10nF) may be required.

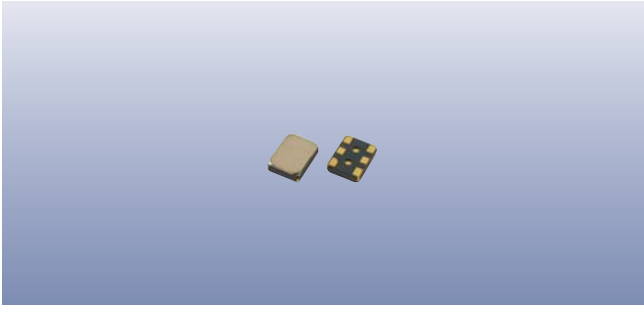

Packaging & Handling

Production quantities supplied on T & R, 1k or 3k pcs per reel.
Small quantities may be supplied on tape (no reel), or in bulk.

 Static sensitive product. Observe proper handling precautions

Marking

S92	DC	Marking type: Laser DC = Date code in YM, eg "CE" = May 2003
FREQUENCY		

	A	B	C	D	E	F	G	H	J	K	L	M
Y	1	2	3	4	5	6	7	8	9	0		
M	Jan	Feb	Mar	Apr	May	Jun	Jul	Aug	Sep	Oct	Nov	Dec

Tape & Reel Specification

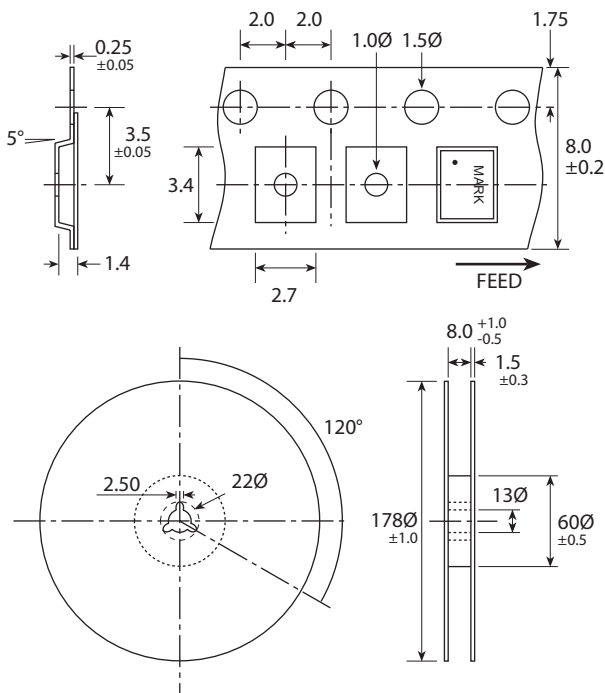

Not to scale. Dimensions in mm. Tolerances ±0.1mm unless otherwise stated

Construction

- ▮▮▮▮ **Ceramic body with gold-plated pads**
- ▮▮▮▮ **Metal lid, seam sealed**

Composition



This product is lead-free, and is fully compliant with the RoHS directive 2002/95/EC



Soldering Profile

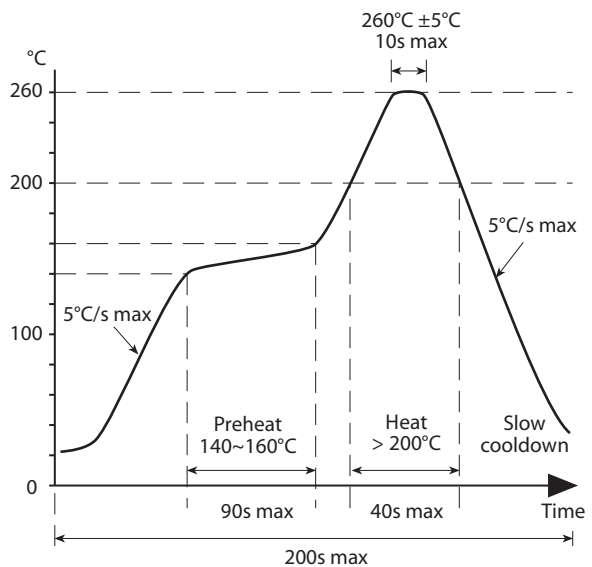

Solder resistance: 260°C x 10 secs x 2.