



# H9926S / H9926CS

Dual N-Channel Enhancement-Mode MOSFET (20V, 6A)

## Description

This N-Channel 2.5V specified MOSFET is a rugged gate version of advanced trench process. It has been optimized for power management applications with a wide range of gate drive voltage (2.5V-10V)

## Features

- $R_{DS(on)}=40m\Omega @ V_{GS}=2.5V, I_D=5.2A$ ;  $R_{DS(on)}=30m\Omega @ V_{GS}=4.5V, I_D=6A$
- High Density Cell Design for Ultra Low On-Resistance
- High Power and Current Handling Capability
- Fully Characterized Avalanche Voltage and Current
- Ideal for Li ion Battery Pack Applications

## Applications

- Battery Protection
- Load Switch
- Power Management

## Absolute Maximum Ratings ( $T_A=25^\circ C$ , unless otherwise noted)

Symbol	Parameter	Ratings	Units
$V_{DS}$	Drain-Source Voltage	20	V
$V_{GS}$	Gate-Source Voltage	$\pm 12$	V
$I_D$	Drain Current (Continuous)	6	A
$I_{DM}$	Drain Current (Pulsed) *1	30	A
$P_D$	Total Power Dissipation @ $T_A=25^\circ C$	2	W
	Total Power Dissipation @ $T_A=75^\circ C$	1.3	W
$T_j, T_{stg}$	Operating and Storage Temperature Range	-55 to +150	$^\circ C$
$R_{\theta JA}$	Thermal Resistance Junction to Ambient*2	62.5	$^\circ C/W$

\*1: Maximum DC current limited by the package  
\*2: 1-in<sup>2</sup> 2oz Cu PCB board

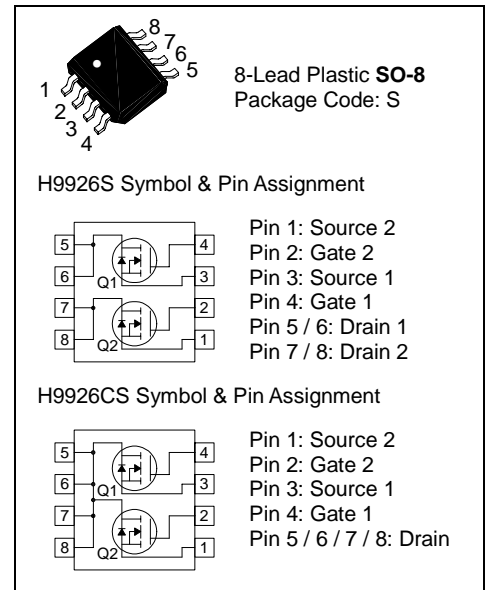



### Electrical Characteristics (T<sub>A</sub>=25°C, unless otherwise noted)

Symbol	Characteristic	Test Conditions	Min.	Typ.	Max.	Unit
--------	----------------	-----------------	------	------	------	------

• **Static**

BV <sub>DSS</sub>	Drain-Source Breakdown Voltage	V <sub>GS</sub> =0V, I <sub>D</sub> =250uA	20	-	-	V
R <sub>DS(on)</sub>	Drain-Source On-State Resistance	V <sub>GS</sub> =2.5V, I <sub>D</sub> =5.2A	-	34	40	mΩ
		V <sub>GS</sub> =4.5V, I <sub>D</sub> =6A	-	25	30	
V <sub>GS(th)</sub>	Gate Threshold Voltage	V <sub>DS</sub> =V <sub>GS</sub> , I <sub>D</sub> =250uA	0.6	-	1.5	V
I <sub>DSS</sub>	Zero Gate Voltage Drain Current	V <sub>DS</sub> =20V, V <sub>GS</sub> =0V	-	-	1	uA
I <sub>GSS</sub>	Gate-Body Leakage Current	V <sub>GS</sub> =±12V, V <sub>DS</sub> =0V	-	-	±100	nA
g <sub>FS</sub>	Forward Transconductance	V <sub>DS</sub> =10V, I <sub>D</sub> =6A	7	13	-	S

• **Dynamic**

Q <sub>g</sub>	Total Gate Charge	V <sub>DS</sub> =10V, I <sub>D</sub> =6A, V <sub>GS</sub> =4.5V	-	4.86	-	nC
Q <sub>gs</sub>	Gate-Source Charge		-	0.92	-	
Q <sub>gd</sub>	Gate-Drain Charge		-	1.4	-	
C <sub>iss</sub>	Input Capacitance	V <sub>DS</sub> =8V, V <sub>GS</sub> =0V, f=1MHz	-	562	-	pF
C <sub>oss</sub>	Output Capacitance		-	106	-	
C <sub>rss</sub>	Reverse Transfer Capacitance		-	75	-	
t <sub>d(on)</sub>	Turn-on Delay Time	V <sub>DD</sub> =10V, I <sub>D</sub> =1A, V <sub>GS</sub> =4.5V R <sub>GEN</sub> =6Ω	-	8.1	-	ns
t <sub>r</sub>	Turn-on Rise Time		-	9.95	-	
t <sub>d(off)</sub>	Turn-off Delay Time		-	21.85	-	
t <sub>f</sub>	Turn-off Fall Time		-	5.35	-	

• **Drain-Source Diode Characteristics**

I <sub>S</sub>	Maximum Diode Forward Current		-	-	1.7	A
V <sub>SD</sub>	Drain-Source Diode Forward Voltage	V <sub>GS</sub> =0V, I <sub>S</sub> =1.7A	-	-	1.2	V

Note: Pulse Test: Pulse Width ≤300us, Duty Cycle ≤2%

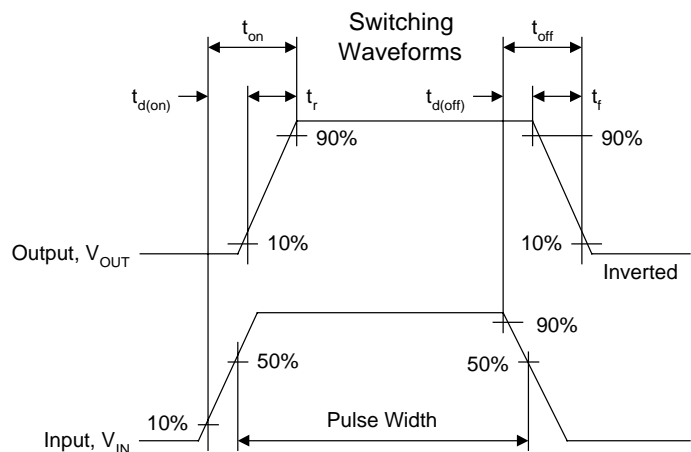
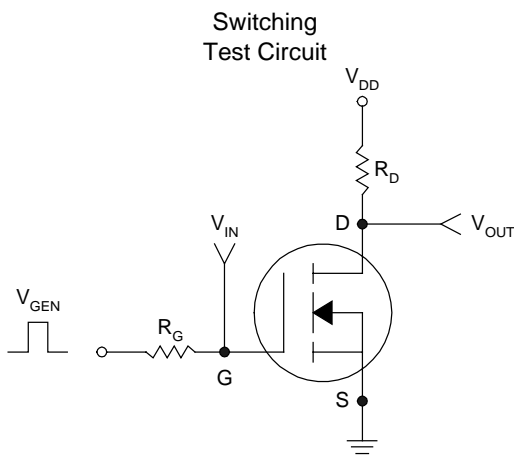



### SO-8 Dimension

8-Lead SO-8 Plastic  
Surface Mounted Package  
HSMC Package Code: S

**H9926S Marking:**

Pb Free Mark  
 Pb-Free: \*●\* (Note)  
 Normal: None

Pin Style: 1.S2 2.G2 3.S1 4.G1 5 & 6.D1 7 & 8.D2

**H9926CS Marking:**

Pb Free Mark  
 Pb-Free: \*●\* (Note)  
 Normal: None

Pin Style: 1.S2 2.G2 3.S1 4.G1 5 & 6 & 7 & 8.D

Note: Green label is used for pb-free packing

Material:

- Lead solder plating: Sn60/Pb40 (Normal), Sn/3.0Ag/0.5Cu or Pure-Tin (Pb-free)
- Mold Compound: Epoxy resin family, flammability solid burning class: UL94V-0

DIM	Min.	Max.
A	4.85	5.10
B	3.85	3.95
C	5.80	6.20
D	1.22	1.32
E	0.37	0.47
F	3.74	3.88
G	1.45	1.65
H	4.80	5.10
I	0.05	0.20
J	0.30	0.70
K	0.19	0.25
L	0.37	0.52
M	0.23	0.28
N	0.08	0.13
O	0.00	0.15

\*: Typical, Unit: mm

#### Important Notice:

- All rights are reserved. Reproduction in whole or in part is prohibited without the prior written approval of HSMC.
- HSMC reserves the right to make changes to its products without notice.
- **HSMC semiconductor products are not warranted to be suitable for use in Life-Support Applications, or systems.**
- HSMC assumes no liability for any consequence of customer product design, infringement of patents, or application assistance.

#### Head Office And Factory:

- **Head Office** (Hi-Sincerity Microelectronics Corp.): 10F., No. 61, Sec. 2, Chung-Shan N. Rd. Taipei Taiwan R.O.C.  
 Tel: 886-2-25212056 Fax: 886-2-25632712, 25368454
- **Factory 1:** No. 38, Kuang Fu S. Rd., Fu-Kou Hsin-Chu Industrial Park Hsin-Chu Taiwan. R.O.C  
 Tel: 886-3-5983621~5 Fax: 886-3-5982931



### Soldering Methods for HSMC's Products

1. Storage environment: Temperature=10°C~35°C Humidity=65%±15%
2. Reflow soldering of surface-mount devices

Figure 1: Temperature profile

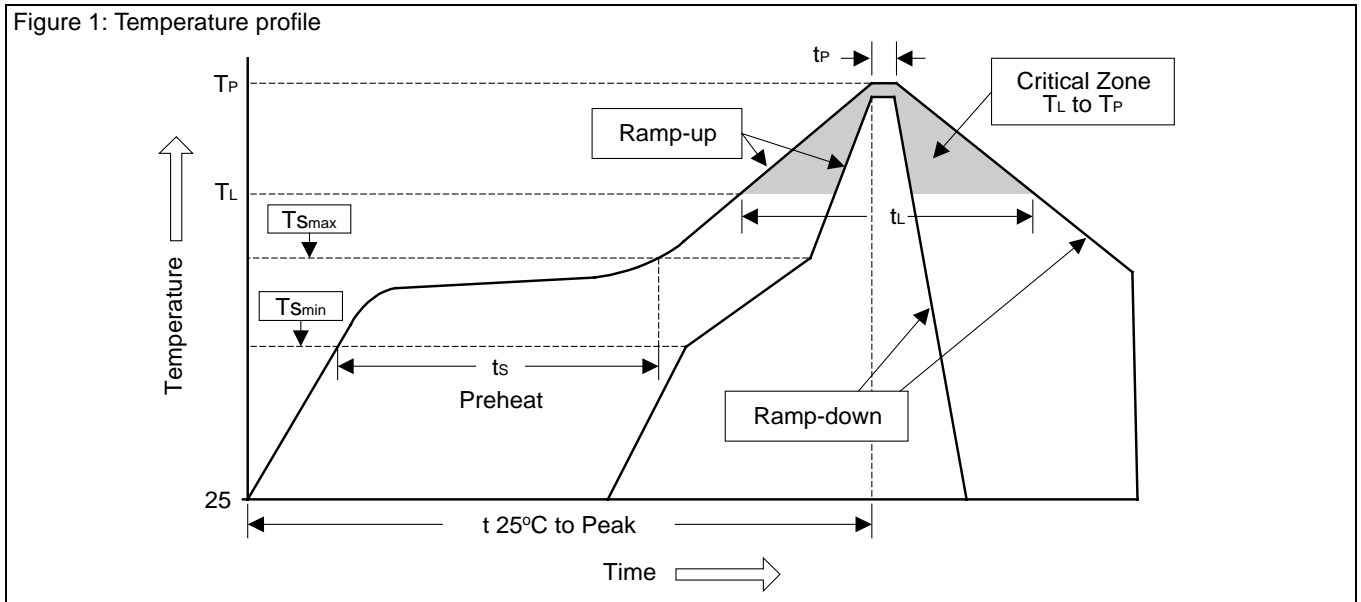

Profile Feature	Sn-Pb Eutectic Assembly	Pb-Free Assembly
Average ramp-up rate ( $T_L$ to $T_P$ )	<3°C/sec	<3°C/sec
Preheat		
- Temperature Min ( $T_{Smin}$ )	100°C	150°C
- Temperature Max ( $T_{Smax}$ )	150°C	200°C
- Time (min to max) ( $t_s$ )	60~120 sec	60~180 sec
$T_{Smax}$ to $T_L$		
- Ramp-up Rate	<3°C/sec	<3°C/sec
Time maintained above:		
- Temperature ( $T_L$ )	183°C	217°C
- Time ( $t_L$ )	60~150 sec	60~150 sec
Peak Temperature ( $T_P$ )	240°C +0/-5°C	260°C +0/-5°C
Time within 5°C of actual Peak Temperature ( $t_p$ )	10~30 sec	20~40 sec
Ramp-down Rate	<6°C/sec	<6°C/sec
Time 25°C to Peak Temperature	<6 minutes	<8 minutes

### 3. Flow (wave) soldering (solder dipping)

Products	Peak temperature	Dipping time
Pb devices.	245°C ±5°C	5sec ±1sec
Pb-Free devices.	260°C +0/-5°C	5sec ±1sec