HA12209F

Audio Signal Processor for Cassette Deck
(Dolby B-type NR with Recording System)

HITACHI

ADE-207-221A (Z)

2nd Edition
Jun. 1999

Description

HA12209F is silicon monolithic bipolar IC providing Dolby noise reduction system*, music sensor system, REC equalizer system and each electronic control switch in one chip.

Functions

- Dolby B-NR × 2 channel
- REC equalizer × 2 channel
- Music sensor × 1 channel
- Each electronic control switch to change REC equalizer, bias, etc.

Features

- REC equalizer is very small number of external parts and have 4 types of frequency characteristics built-in.
- 2 types of input for PB, 1 type of input for REC.
- 70 μ -PB equalizer changing system built-in.
- Dolby NR with dubbing double cassette decks.
Unprocessed signal output available from recording out terminals during PB mode.
- Provide stable music sensor system, available to design music sensing time and level.
- Controllable from direct micro-computer output.
- Bias oscillator control switch built-in.
- NR ON/OFF and REC/PB fully electronic control switching built-in.
- Normal-speed/high-speed, TYPE I/TYPE II and PB equalizer fully electronic control switching built-in.
- Available to reduce substrate-area because of high integration and small external parts.

* Dolby is a trademark of Dolby Laboratories Licensing Corporation.
A license from Dolby Laboratories Licensing Corporation is required for the use of this IC.

HA12209F

Ordering Information

Standard Level

Product	Package	PB-OUT Level	REC-OUT Level	Dolby Level	Operating Voltage	
					Min	Max
HA12209F	FP-56	580mVrms	300mVrms	300mVrms	10V	15V

Function

Product	Dolby B-NR	REC-EQ	Music Sensor	REC/PB Selection
HA12209F	○	○	○	○

Note: Depending on the employed REC/PB head and test tape characteristics, there is a rare case that the REC-EQ characteristics of this LSI can not be matched to the required characteristics because of built-in resistors which determined the REC-EQ parameters in this case, please inquire the responsible agent because the adjustment of built-in resistor is necessary.

Pin Description, Equivalent Circuit ($V_{cc}=12V$, $T_a=25^\circ C$, No signal, The value in the table show typical value.)

Pin No.	Pin Name	Note	Equivalent Circuit	Pin Description
52	AIN (R)	$V = V_{cc} / 2$		PB A deck input
48	AIN (L)			
54	BIN (R)			PB B deck input
45	BIN (L)			
56	RIN (R)			REC input
44	RIN (L)			
6	EQIN (R)			REC equalizer input
37	EQIN (L)			
4	DET (R)	$V = 2.6V$		Time constant pin for Dolby-NR
39	DET (L)			
49	RIP	$V = V_{cc} / 2$		Ripple filter
1	BIAS1	$V = 0.6V$		Dolby bias current input
42	BIAS2	$V = 1.3V$		REC equalizer bias current input

HA12209F

Pin Description, Equivalent Circuit ($V_{CC}=12V$, $T_a=25^\circ C$, No signal, The value in the table show typical value.) (cont)

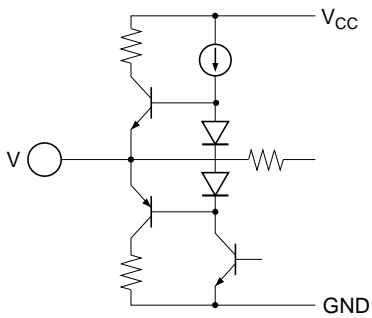
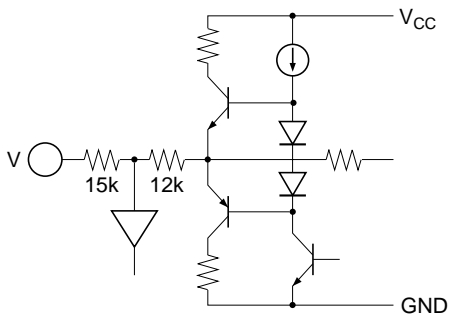
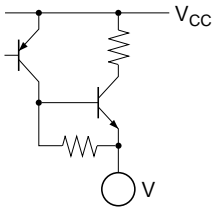
Pin No.	Pin Name	Note	Equivalent Circuit	Pin Description
3	PBOUT (R)	$V = V_{CC} / 2$		PB output
40	PBOUT (L)			
5	RECOU (R)			REC output
38	RECOU (L)			
8	EQOUT (R)			Equalizer output
35	EQOUT (L)			
32	MAOUT			MS amp. input *1
53	ABO (R)	$V = V_{CC} / 2$		Time constant pin for PB equalizer
46	ABO (L)			
25	BIAS (C)	$V = V_{CC} - 0.7$		REC bias current output
26	BIAS (N)			

Note: 1. MS : Music Sensor

Pin Description, Equivalent Circuit ($V_{CC}=12V$, $T_a=25^\circ C$, No signal, The value in the table show typical value.) (cont)

Pin No.	Pin Name	Note	Equivalent Circuit	Pin Description
29	MSDET	$I = 0\mu A$		Time constant pin for MS *1
31	MSIN	$V = V_{CC} / 2$		MS input
33	MAI	$V = V_{CC} / 2$		MS amp. output
27	MSOUT	$I = 0\mu A$		MS output (to MPU)

Note: 1. MS : Music Sensor

HA12209F

Pin Description, Equivalent Circuit ($V_{cc}=12V$, $T_a=25^\circ C$, No signal, The value in the table show typical value.) (cont)

Pin No.	Pin Name	Note	Equivalent Circuit	Pin Description
10	PB A/B	$I = 20\mu A$		Mode control input
11	A 120/70			
12	NORM/HIGH			
14	B 120/70			
16	BIAS ON/OFF			
17	RM ON/OFF			
19	NR ON/OFF			
20	REC/PB			
21	LM ON/OFF			
22, 23	V_{cc}	$V = V_{cc}$		Power supply
50, 51	GND	$V = 0V$		GND pin
2, 7, 9, 13, 15, 18, 24, 28, 30, 34, 36, 41, 43, 47, 55	NC			No connection

Block Diagram

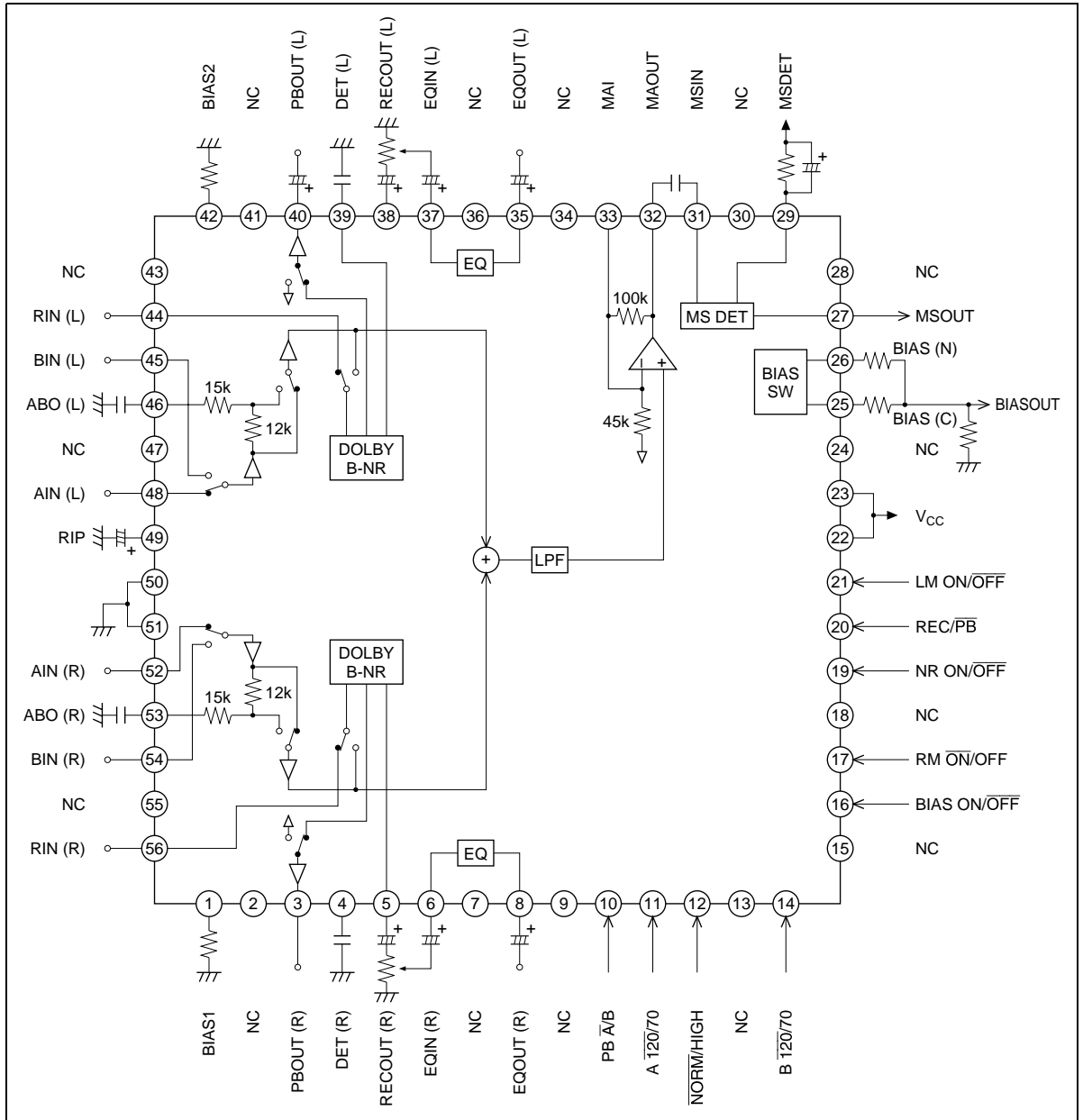

HA12209F

Functional Description

Power Supply Range

HA12209F is designed to operate on single supply.

Table 1 Sply Voltage

Item	Power Supply Range
Single Supply	10V to 15V

Note: The lower limit of supply voltage depends on the line output reference level.
The minimum value of the overload margin is specified as 12dB by Dolby Laboratories.

Reference Voltage

For this IC, the reference voltage ($V_{CC}/2$) occurrence device is built-in as AC grand. A capacitor for a ripple filter is greatly small characteristic with 1/100 compared with conventional device.

And, the reference voltage are provided for the left channel and the right channel separately.

The block diagram is shown as figure 1.

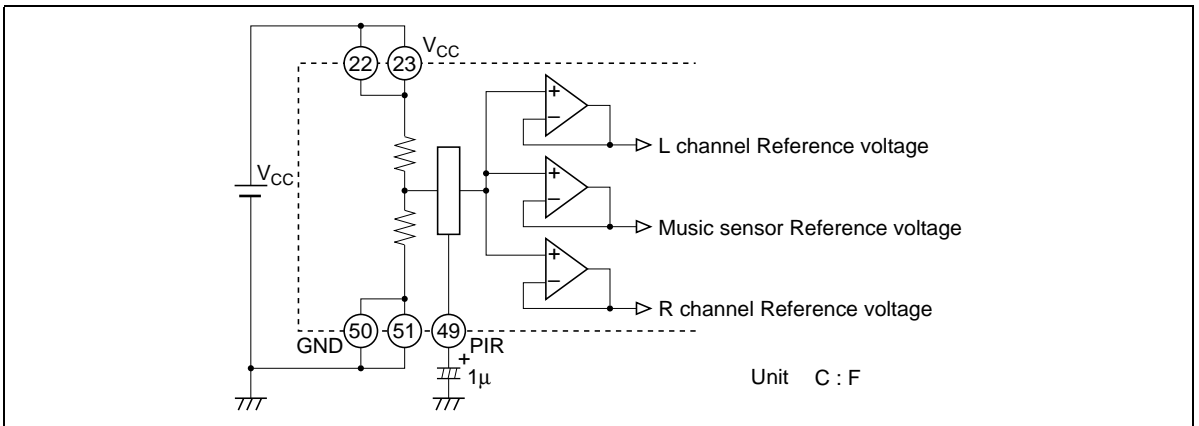

Figure 1 Reference Voltage

Operating Mode Control

HA12209F provides fully electronic switching circuits. And each operating mode control is controlled by parallel data (DC voltage).

Table 2 Control Voltage

Pin No.	Lo	Hi	Unit	Test Condition
10, 11, 12, 14, 16, 17, 19, 20, 21	-0.2 to 1.0	4.0 to 5.3	V	

- Note:
1. Each pins are on pulled down with 100kΩ internal resistor. Therefore, it will be low-level when each pins are open.
 2. Over shoot level and under shoot level of input signal must be the standardized. (High: 5.3V, Low: -0.2V)
 3. For reduction of pop noise, connect 1μF to 22μF capacitor with mode control pins. But it is impossible to reduce completely in regard to Line mute, therefore, use external mute at the same time.

Input Block Diagram and Level Diagram

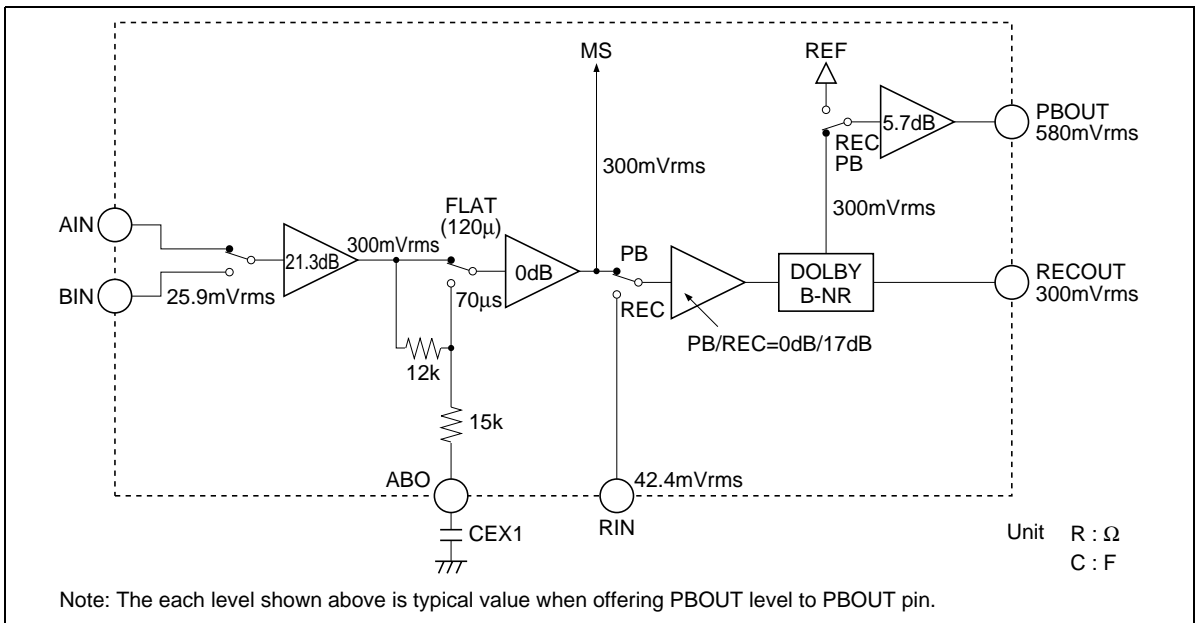

Figure 2 Input Block Diagram

HA12209F

PB Equalizer

By switching logical input level of 11 pin (for Ain) and 14 pin (for Bin), you can equalize corresponding to tape position at play back mode.

With the capacity CEX1 capacitance that we showed for figure 2 $70 \mu s$ by the way figure seem to 3 they are decided.

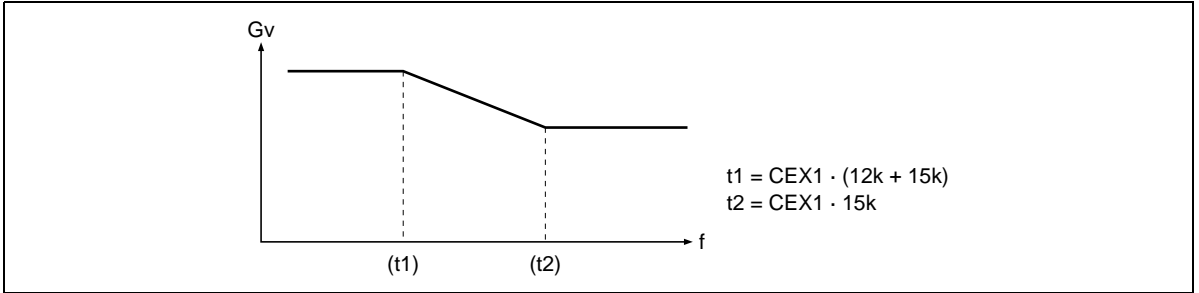

Figure 3 Frequency Characteristic of PB Equalizer

The sensitivity Adjustment of Music Sensor

Adjusting MS amp. gain by external resistor, the sensitivity of music sensor can set up.

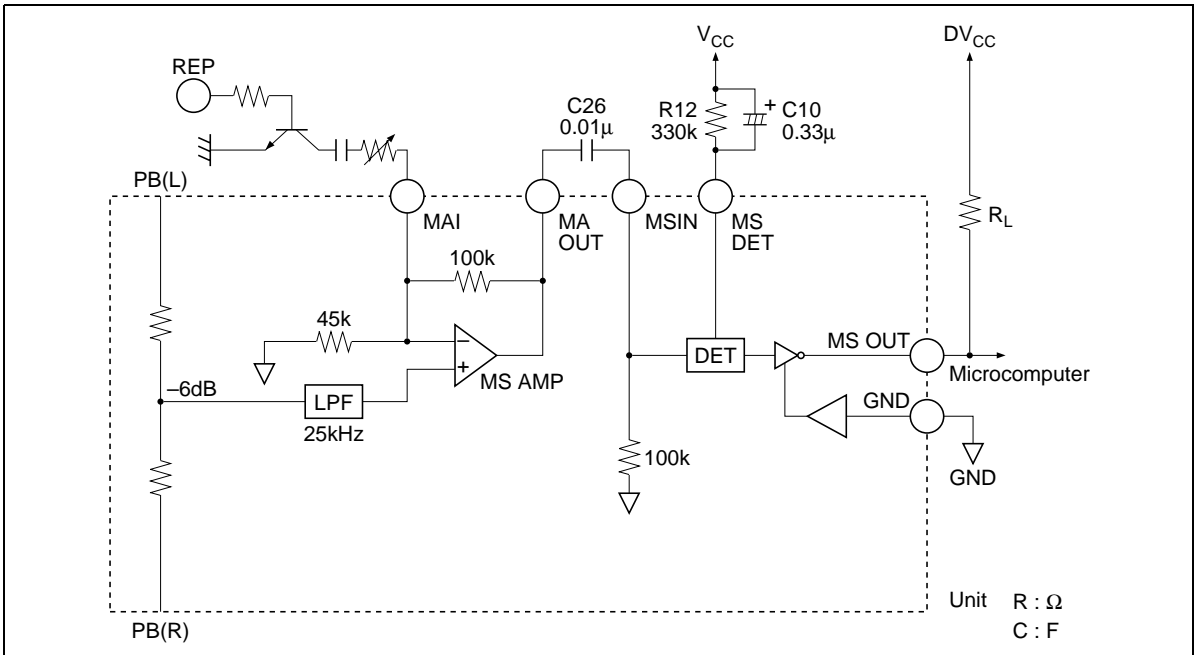

Figure 4 Music Sensor Block Diagram

The sensitivity of Music Sensor

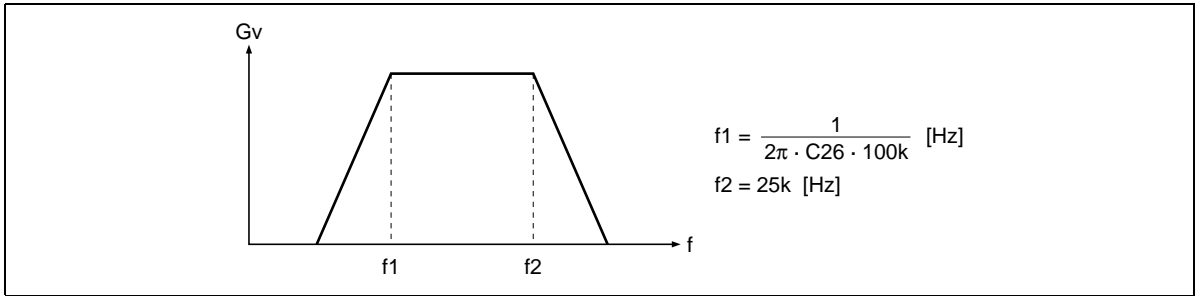

Figure 5 Frequency Characteristic of MSIN

Occasion of the external component of figure 4, f1 is 159Hz. A standard level of MS input pin 25.9mVrms, therefore, the sensitivity of music sensor (S) can request it, by lower formulas.

$$\begin{aligned}
 &A = \text{MS Amp Gain} \\
 &B = \text{PB input Gain} \times (1/2)^1 \\
 &C = \text{Sensed voltage} \\
 &20\log(A \times B) = D \text{ [dB]} \\
 &\text{PB input Gain} = 21.3 \text{ [dB]} \\
 &S = 20\log \frac{C}{25.9 \cdot A \cdot B} \text{ [dB]} \\
 &S = 14 - D \text{ [dB]}
 \end{aligned}$$

Note: 1. Case of one-sided channel input.

Time Constant of Detection

Figure 6(1) generally shows that detection time is in proportion to value of capacitor C10. But, with Attack*² and Recovery*³ the detection time differs exceptionally.

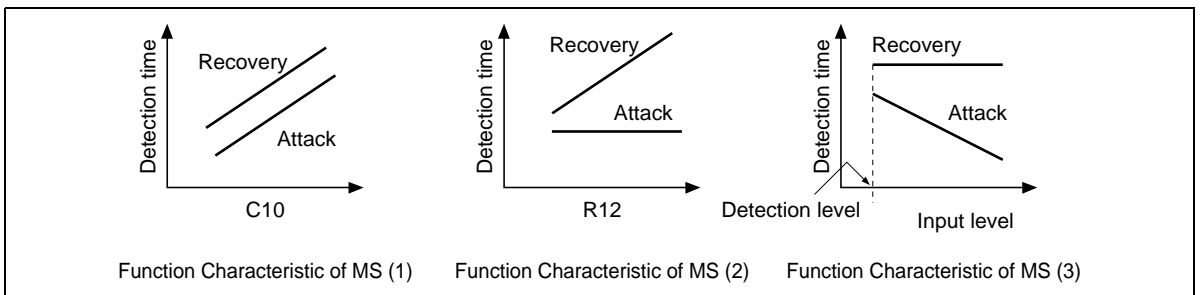

Figure 6 Function Characteristics of MS

Like the figure 6(2), Recovery time is variably possible by value of resistor R12. But Attack time gets about fixed value. Attack time has dependence by input level. When a large signal is inputted, Attack time is short tendency.

Note: 2. Attack : Non-music → Music

3. Recovery : Music → Non-music

HA12209F

Music Sensor Output (MSOUT)

As for internal circuit of music sensor block, music sensor out pin is connected to the collector of NPN type directly, output level will be “high” when sensing no signal. And output level will be “low” when sensing signal.

Connection with microcomputer, it is requested to use external pull up resistor ($R_L = 10k$ to $22k\Omega$)

Note: Supply voltage of MSOUT pin must be less than V_{cc} voltage.

The Tolerances of External Components

For Dolby NR precision securing, please use external components shown at figure 7.

If leak-current are a few electrolytic-capacitor, it can be applicable to C2 and C15.

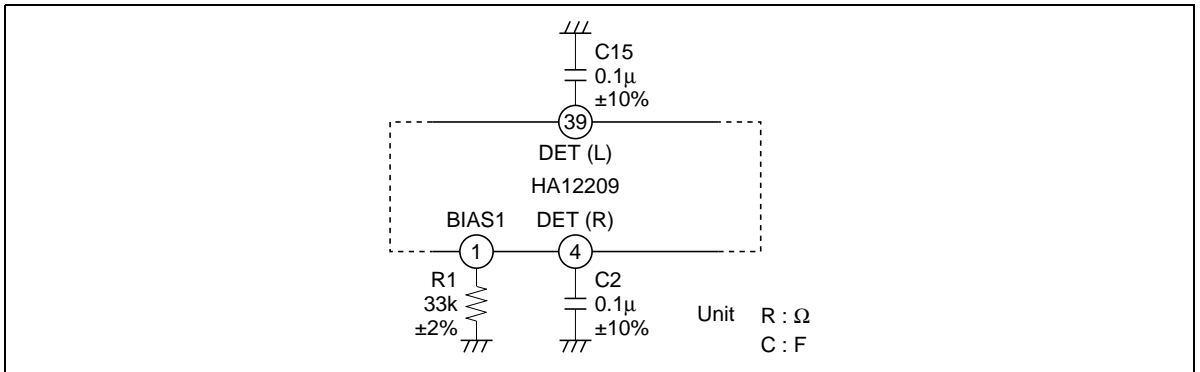

Figure 7 Tolerance of External Components

Low-Boost

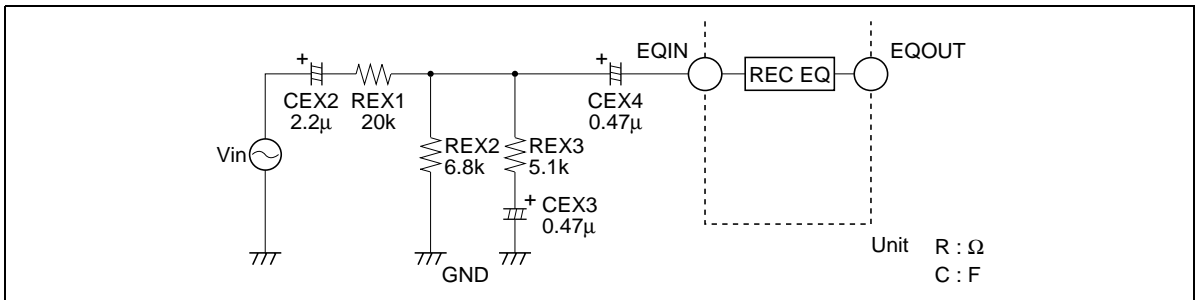

Figure 8 Example of Low Boost Circuit

External components shown figure 8 gives frequency response to take 6dB boost. And cut off frequency can request it, by lower formulas.

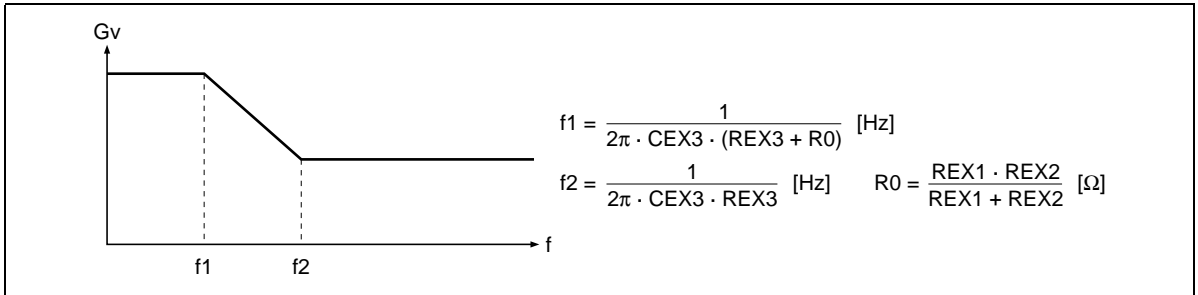

Figure 9 Frequency Characteristic of Low-Boost

Bias Switch

This series built-in DC voltage generator for bias oscillator and its bias switches.

External resistor R8, R10 which corresponded with tape positions and bias out voltage are relater with below.

$$V_{bias} \cong \left(\frac{R9}{(R10 \text{ or } R8) + R9} \right) \times (VCC - 0.7) \text{ [V]}$$

Bias switch follows to a logic of 14 pin (B 120/70).

Note: A current that flows at bias out pin, please use it less than 5mA.

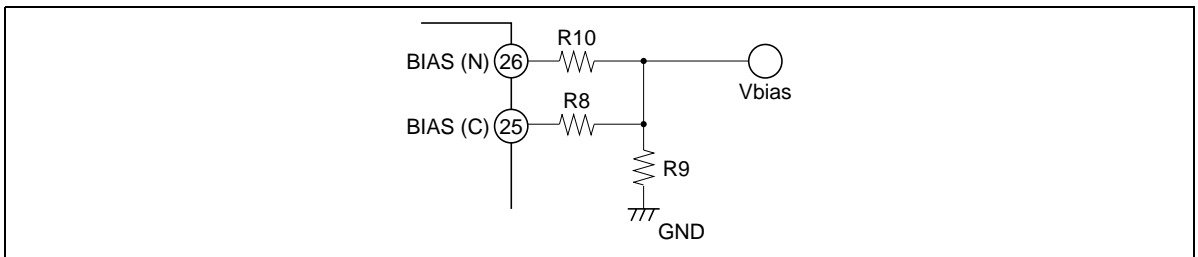

Figure 10 External Components of Bias Block

HA12209F

Absolute Maximum Rating (Ta=25°C)

Item	Symbol	Rating	Unit	Note
Max supply voltage	V _{cc} max	16	V	
Power dissipation	P _T	500	mW	Ta ≤ 75°C
Operating temperature	T _{opr}	-40 to +75	°C	
Storage temperature	T _{stg}	-55 to +125	°C	

Electrical Characteristics (Ta = 25°C, V_{cc} = 12V, Dolby Level = REC-OUT Level = 300mVrms = 0dB)

Item	Symbol	Min	Typ	Max	Unit	Test Condition						
						IC Condition*1						
						NR ON/OFF	REC/PB A/B	MUTE 120µ/70µ	fin (Hz)	RECOUT level (dB)	Other	
Quiescent current	I _Q	15.0	23.0	30.0	mA	OFF	PB A	120	ON	—	No signal	
Input AMP. gain	G _V PB	25.5	27.0	28.5	dB	OFF	PB A/B	120	OFF	1k	0	
	G _V REC	21.2	22.7	24.2	dB	OFF	REC A	120	OFF	1k	0	
B type Encode boost	ENC 2k (1)	2.8	4.3	5.8	dB	ON	REC A	120	OFF	2k	-20	
	ENC 2k (2)	7.0	8.5	10.0	dB	ON	REC A	120	OFF	2k	-30	
	ENC 5k (1)	1.7	3.2	4.7	dB	ON	REC A	120	OFF	5k	-20	
	ENC 5k (2)	6.7	8.2	9.7	dB	ON	REC A	120	OFF	5k	-30	
Signal handling	Vo max	12.0	13.0	—	dB	ON	REC A	120	OFF	1k	—	THD=1%*2
Signal to noise ratio	S/N	64.0	70.0	—	dB	ON	REC A	120	OFF	1k	—	Rg=5.1kΩ, CCR/ARM
Total harmonic distortion	T.H.D.	N	0.05	0.3	%	ON	REC A	120	OFF	1k	0	
Channel separation	CTRL (1)	70.0	80.0	—	dB	OFF	PB A/B	120	OFF	1k	+12	
	CTRL (2)	75.0	85.0	—	dB	OFF	REC A	120	OFF	1k	+12	
Crosstalk	CT A/B	60.0	70.0	—	dB	OFF	PB A/B	120	OFF	1k	+12	
	CT R/P	70.0	80.0	—	dB	OFF	REC/PB A/B	120	OFF	1k	+12	
Mute attenuation	MUTE	70.0	80.0	—	dB	OFF	PB A	120	ON	1k	+12	
70µ EQ gain	G _V EQ 1k	24.0	25.5	27.0	dB	OFF	PB A/B	70	OFF	1k	0	
	G _V EQ 10k	20.8	22.3	23.8	dB	OFF	PB A/B	70	OFF	10k	0	
MS sensing level*3	V _{ON}	-15.4	-11.4	-7.4	dB	OFF	PB A	120	OFF	5k	—	
MS output low level	V _{OL}	—	1.0	1.5	V	OFF	PB A	120	OFF	—	—	
MS output leak current	I _{OH}	—	—	2.0	µA	OFF	PB A	120	OFF	—	—	
Control voltage	V _{IL}	-0.2	—	1.0	V	—	—	—	—	—	—	
	V _{IH}	4.0	—	5.3	V	—	—	—	—	—	—	

Note: 1. Other IC condition : REC-MUTE OFF, TYPE I, Normal speed, Bias OFF
 2. V_{CC}=10V
 3. For inputting signal to one side channel

Electrical Characteristics (Ta=25°C, V_{cc} = 12V, Dolby Level = REC-OUT Level = 300mVrms = 0dB) (cont)

Item	Symbol	Min	Typ	Max	Unit	Test Condition
Equalizer S/N	S/N (EQ)	55	58	—	dB	TYPE I NORM Rg=5.1kΩ, A-WTG Filter
Equalizer maximum input	V _{in} max (EQ)	10.5	12.5	—	dB	TYPE I NORM f=1kHz, THD=1%, V _{in} =-26dBs=0dB
Equalizer Total Harmonic Distortion	T.H.D. (EQ)	—	0.2	0.5	%	TYPE I NORM f=1kHz, V _{in} =-26dBs
Equalizer offset voltage	V _{ofs} (EQ)	-500	0	500	mV	TYPE I NORM No signal
Equalizer frequency response (TYPE I-NORM)	G _{VEQ-1N1}	18.5	20.0	21.5	dB	TYPE I NORM f=1kHz, V _{in} =-46dBs
	G _{VEQ-1N2}	19.4	21.4	23.4	dB	f=5kHz, V _{in} =-46dBs
	G _{VEQ-1N3}	29.1	32.1	35.1	dB	f=12.5kHz, V _{in} =-46dBs
Equalizer frequency response (TYPE II-NORM)	G _{VEQ-2N1}	21.4	22.9	24.4	dB	TYPE II NORM f=1kHz, V _{in} =-46dBs
	G _{VEQ-2N2}	23.3	25.3	27.3	dB	f=5kHz, V _{in} =-46dBs
	G _{VEQ-2N3}	32.0	35.0	38.0	dB	f=12.5kHz, V _{in} =-46dBs
Equalizer frequency response (TYPE I-HIGH)	G _{VEQ-1H1}	17.7	19.2	20.7	dB	TYPE I HIGH f=2kHz, V _{in} =-46dBs
	G _{VEQ-1H2}	19.8	21.8	23.8	dB	f=10kHz, V _{in} =-46dBs
	G _{VEQ-1H3}	31.0	34.0	37.0	dB	f=25kHz, V _{in} =-46dBs
Equalizer frequency response (TYPE II-HIGH)	G _{VEQ-2H1}	20.5	22.0	23.5	dB	TYPE II HIGH f=2kHz, V _{in} =-46dBs
	G _{VEQ-2H2}	24.3	26.3	28.3	dB	f=10kHz, V _{in} =-46dBs
	G _{VEQ-2H3}	35.7	38.7	41.7	dB	f=25kHz, V _{in} =-46dBs
REC MUTE attenuation	REC-MUTE	60	70	—	dB	TYPE I NORM f=1kHz, V _{in} =-14dBs
Bias out Max level	Bias on	V _{cc}	V _{cc}	—	V	RL=2.4kΩ+270Ω
	Bias off	-1.4	-1.0	—	mV	
Bias out offset	Bias off	-100	0	100	mV	RL=2.4kΩ+270Ω

Test Circuit

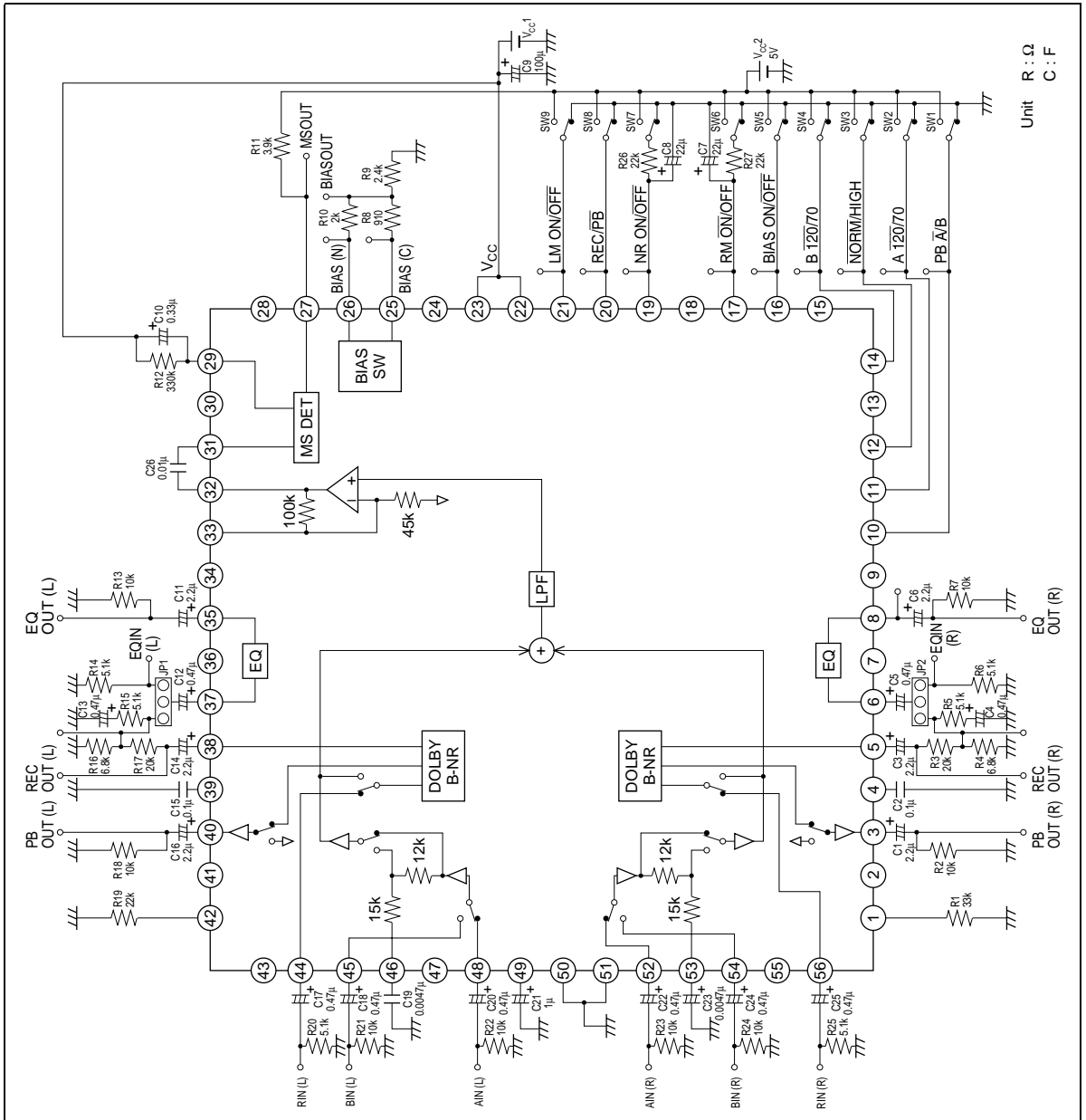

Unit R : Ω
C : F

HA12209F

Parallel Data Format

Pin No.	Pin Name	Lo	Hi	Mode "Pin Open"
10	PB \bar{A}/B	Ain ^{*1}	Bin ^{*1}	Lo
11	A $\bar{120}/70$	*1	*1	Lo
12	$\bar{N}ORM/HIGH$	Normal speed	High speed	Lo
14	B $\bar{120}/70$	REC EQ TYPE I ^{*1} Bias TYPE I	REC EQ TYPE II ^{*1} Bias TYPE II	Lo
16	BIAS ON/ $\bar{O}FF$	BIAS OFF	BIAS OFF	Lo
17	RM $\bar{O}N/OFF$	REC MUTE ON	REC MUTE OFF	Lo
19	NR ON/ $\bar{O}FF$	NR OFF	NR ON	Lo
20	REC/ $\bar{P}B$	PB MODE	REC MODE	Lo
21	LM ON/ $\bar{O}FF$	LINE MUTE OFF	LINE MUTE ON	Lo

Note: 1. PB EQ LOGIC

		PB \bar{A}/B	
A $\bar{120}/70$	B $\bar{120}/70$	Lo	Hi
Lo	Lo	FLAT	FLAT
Lo	Hi	FLAT	70 μ
Hi	Lo	70 μ	FLAT
Hi	Hi	70 μ	70 μ

Characteristics Curve

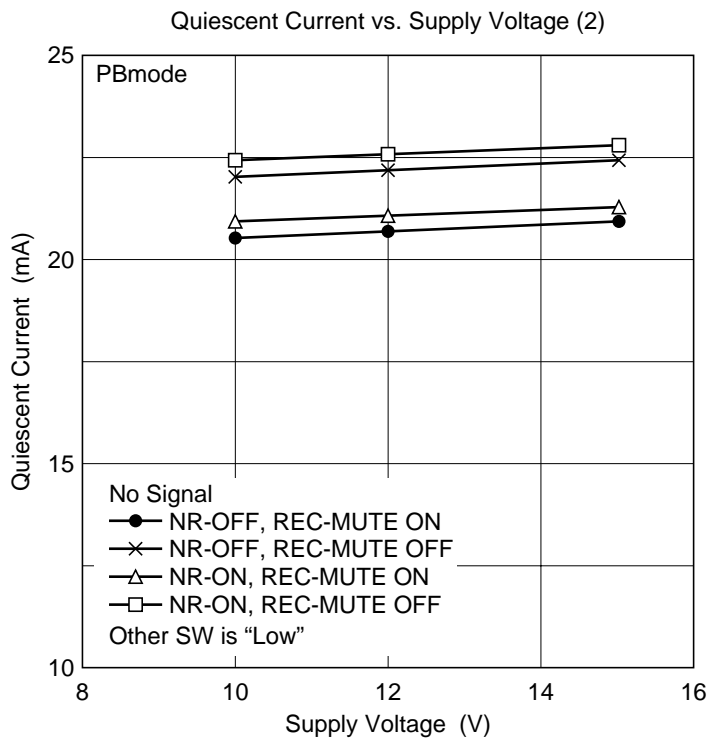
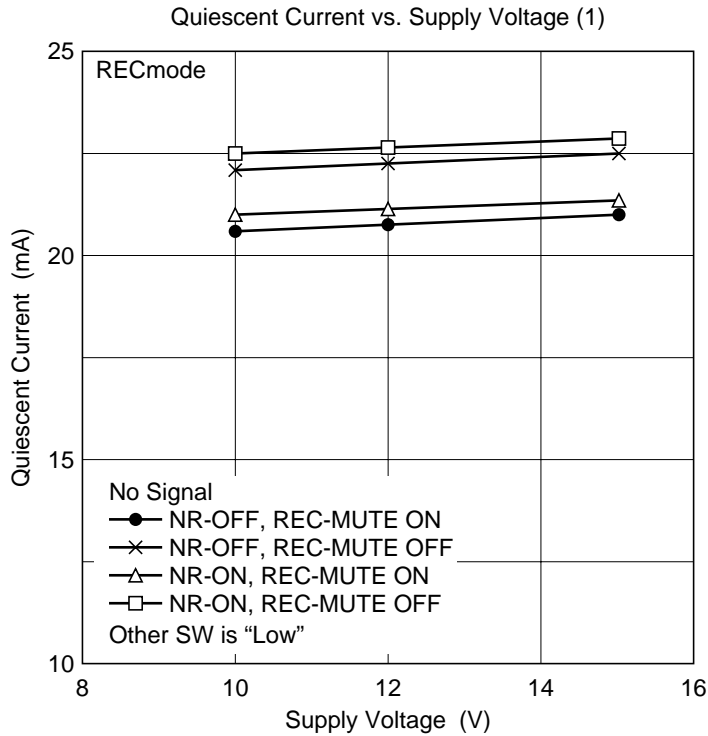

Input Amp. Gain vs. Frequency (1)

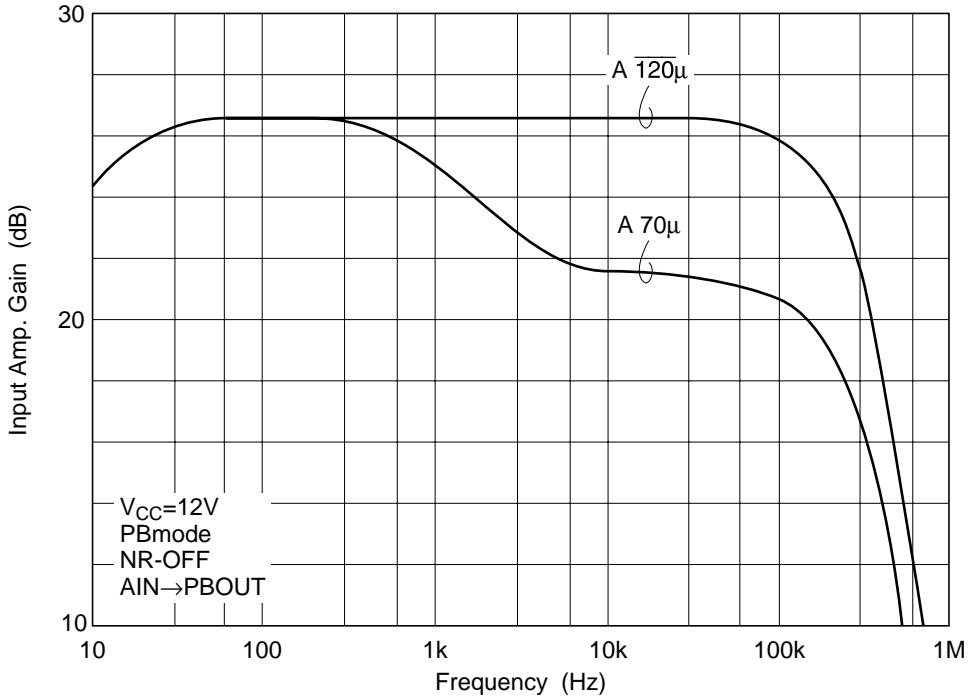

Input Amp. Gain vs. Frequency (2)

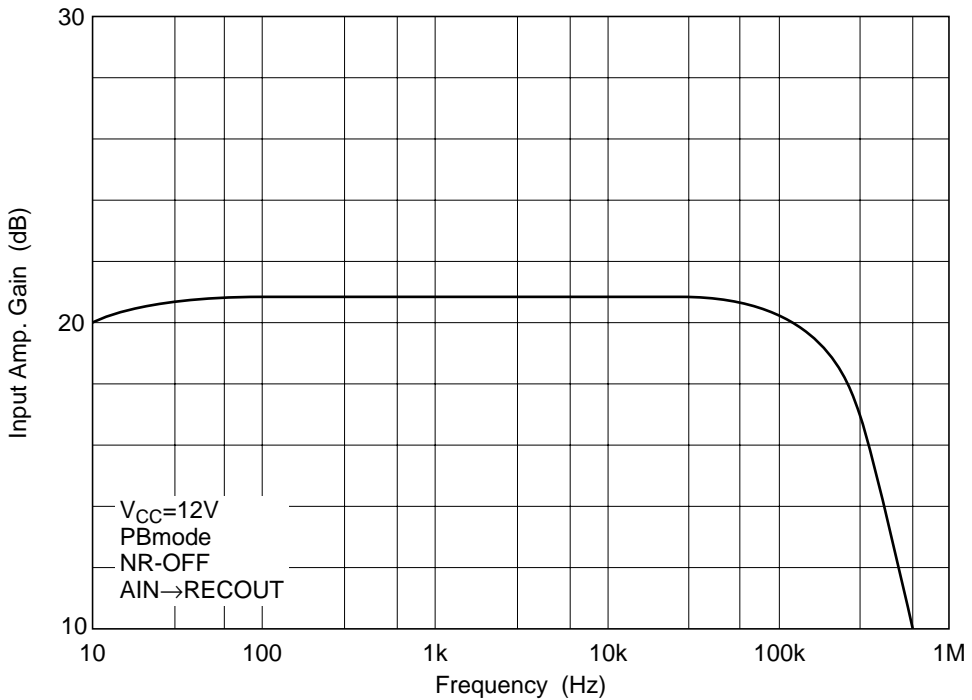

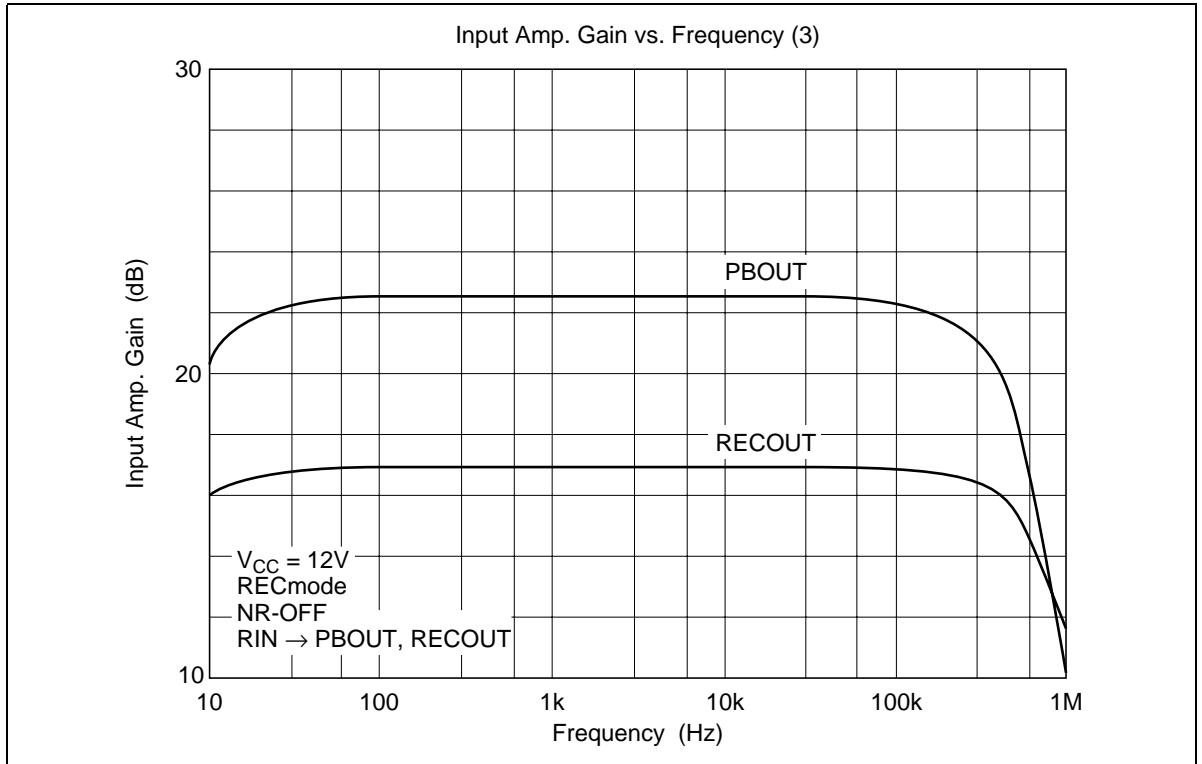

Encode Boost vs. Frequency

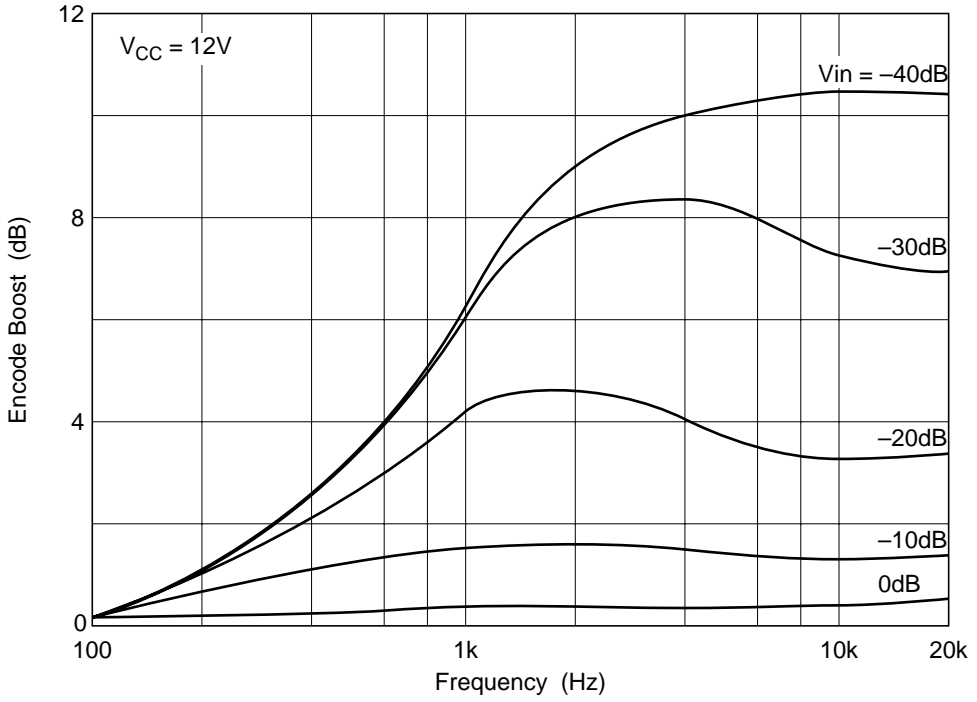

Decode Cut vs. Frequency

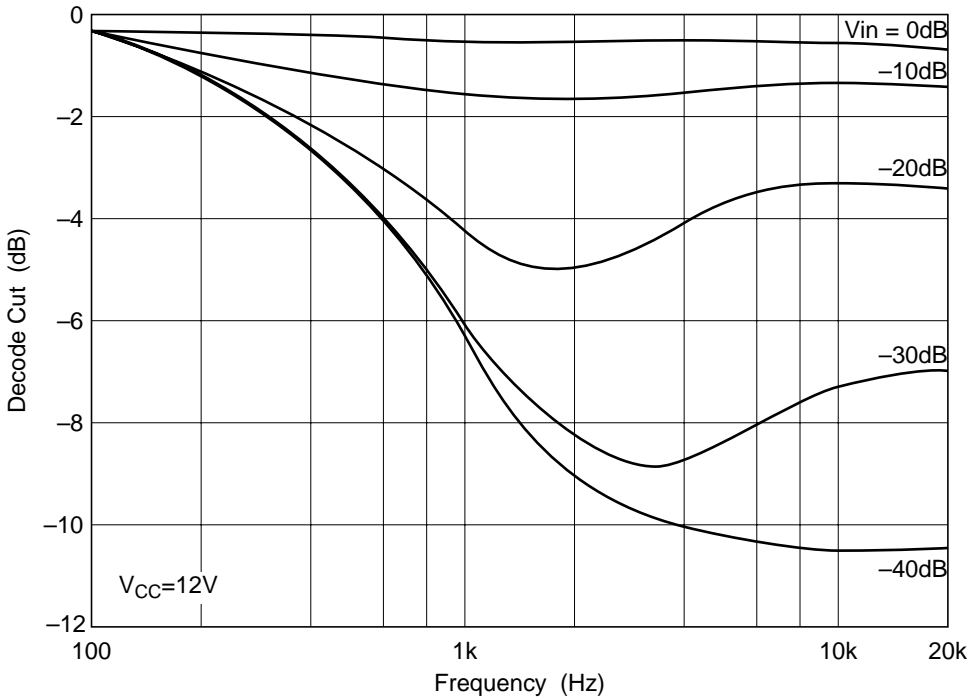

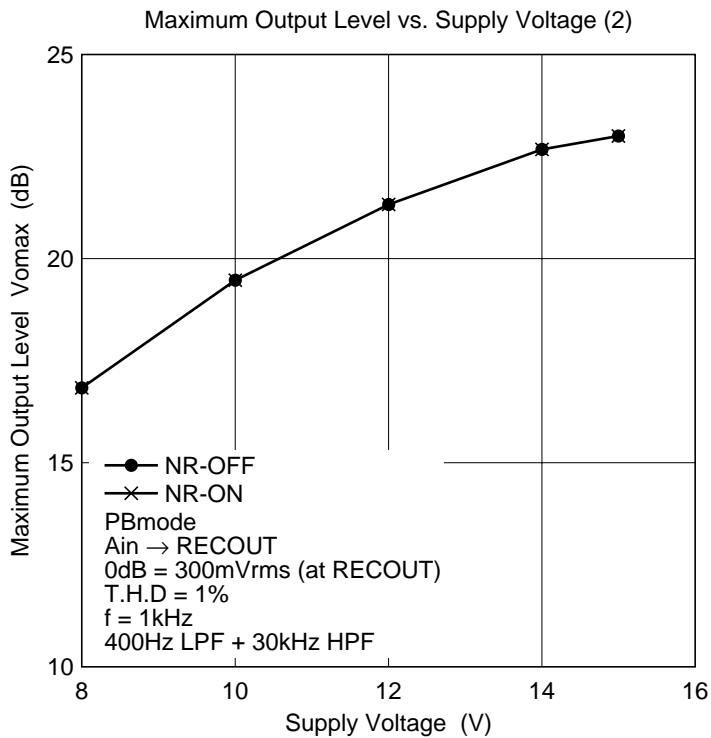
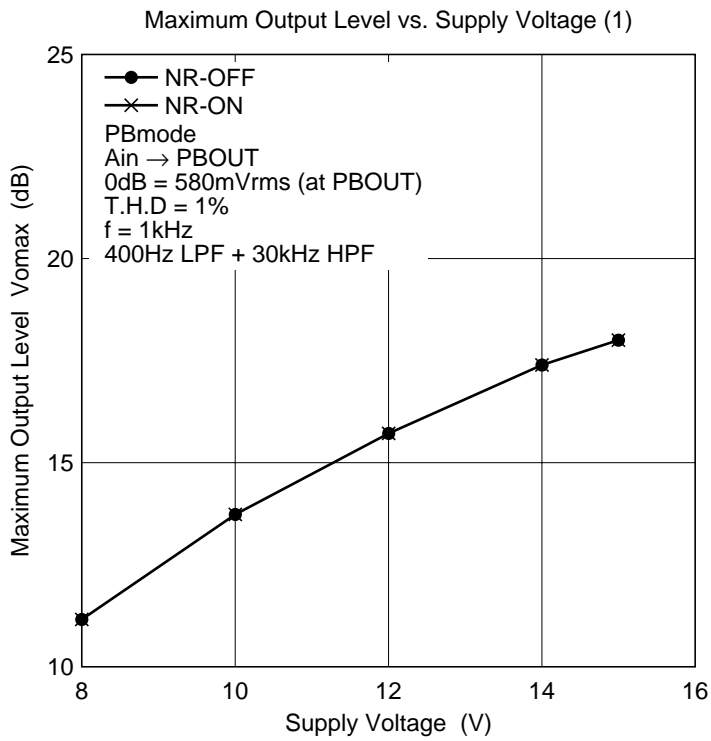

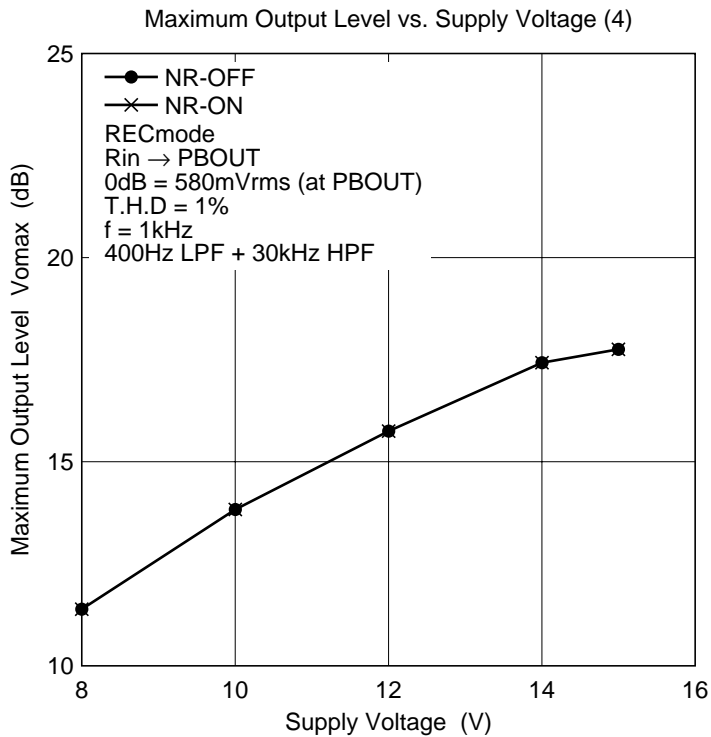
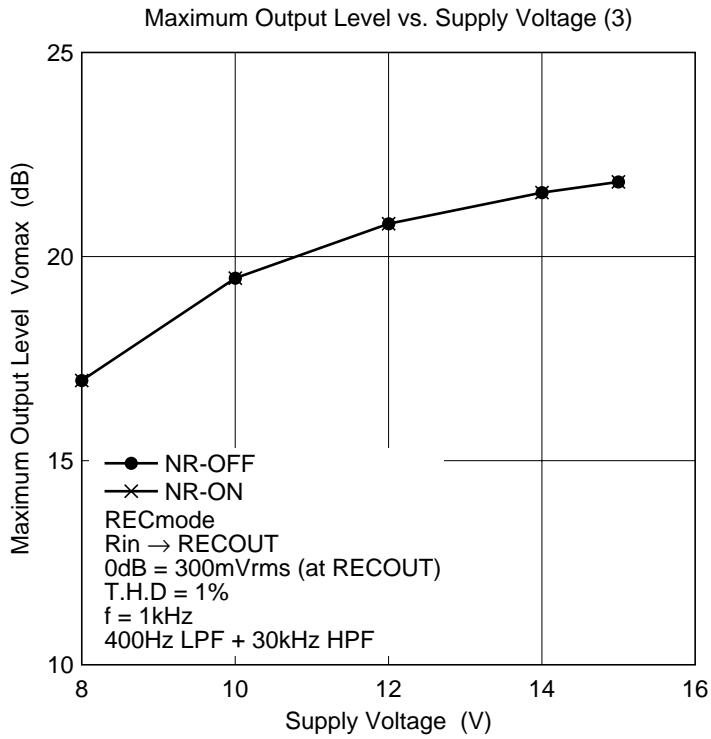

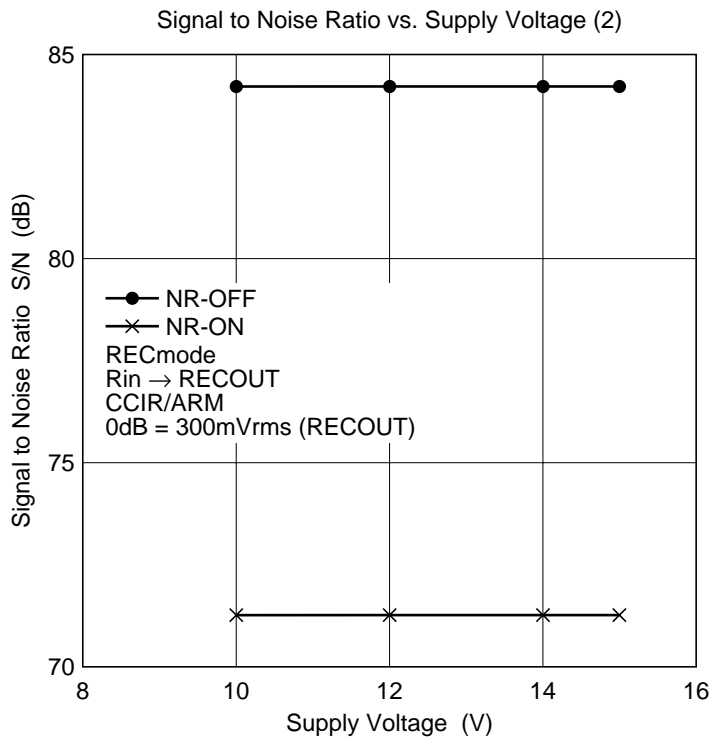
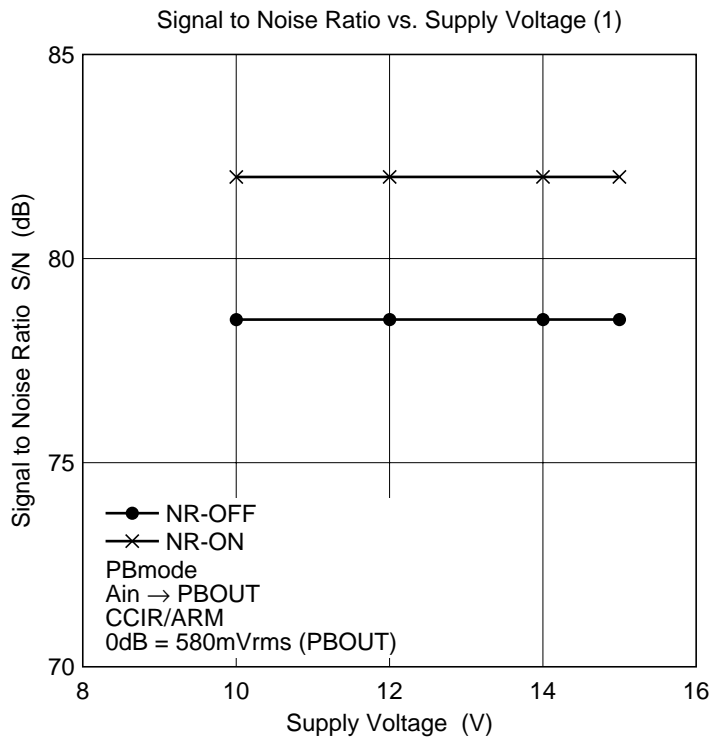

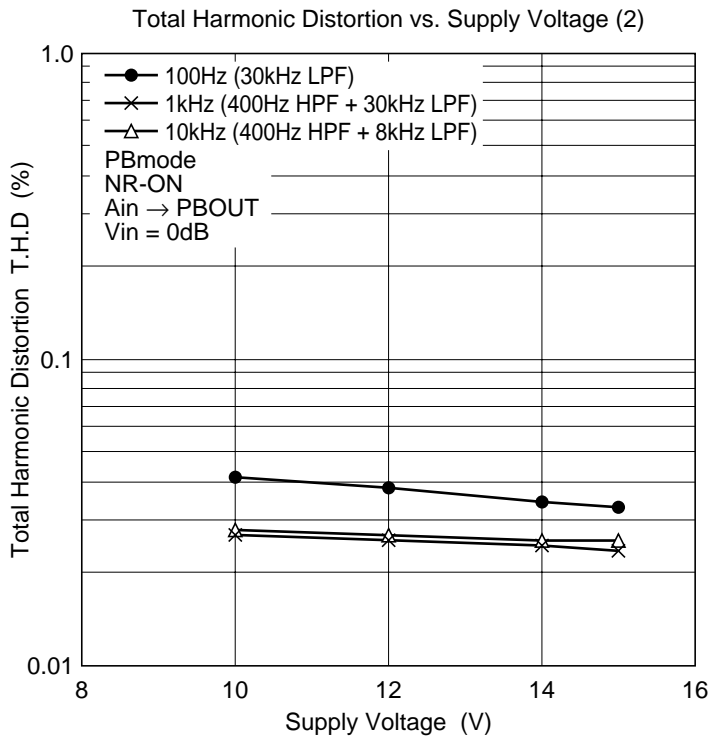
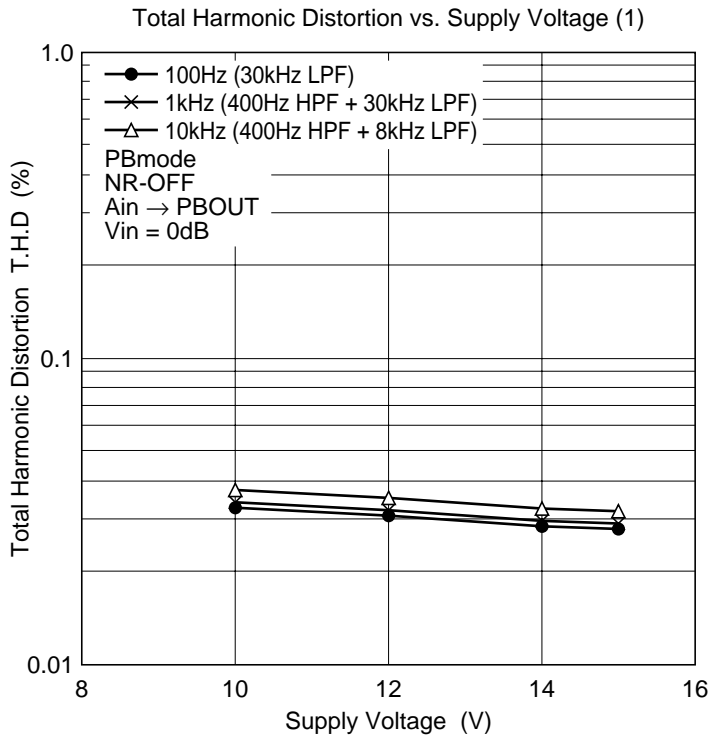

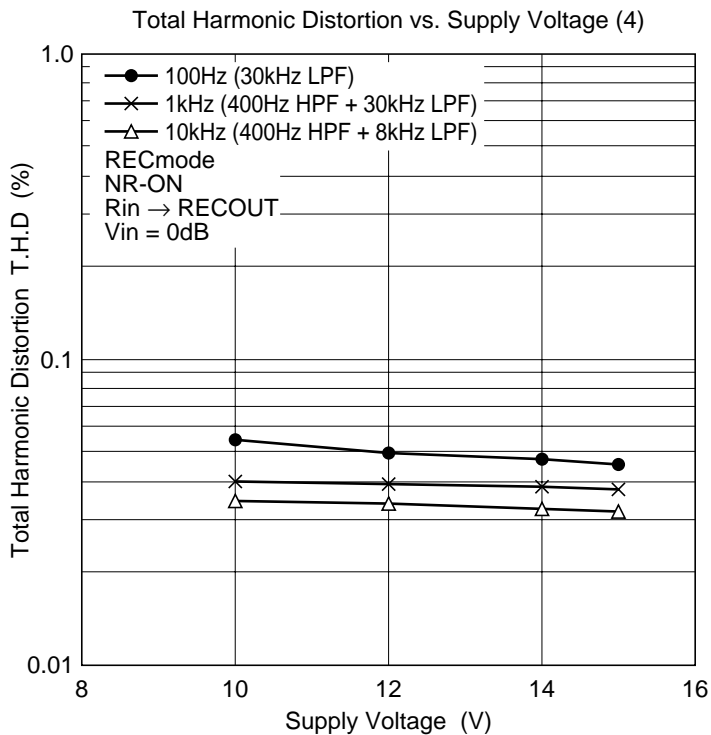
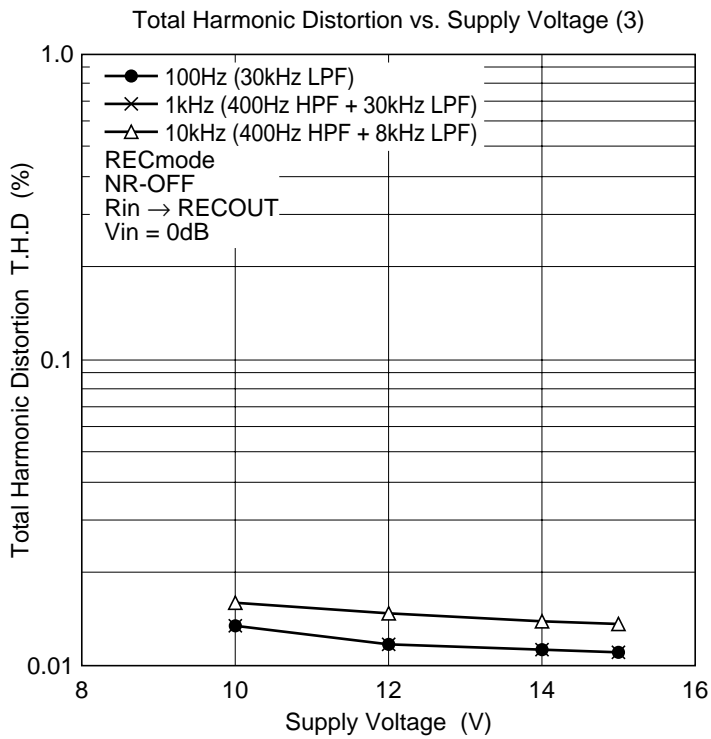

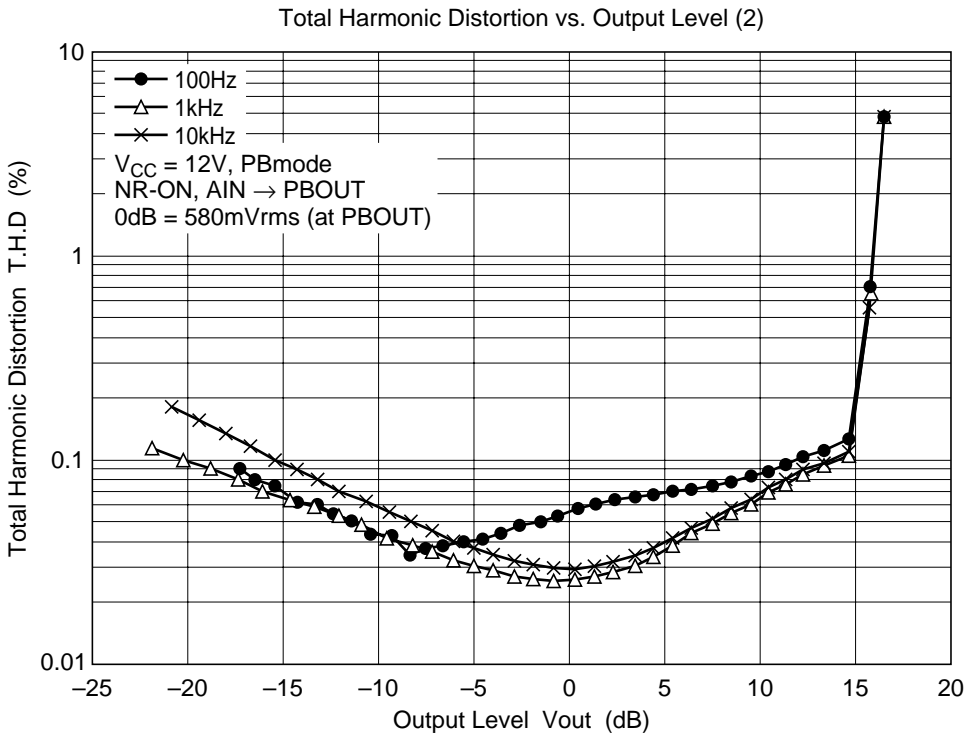
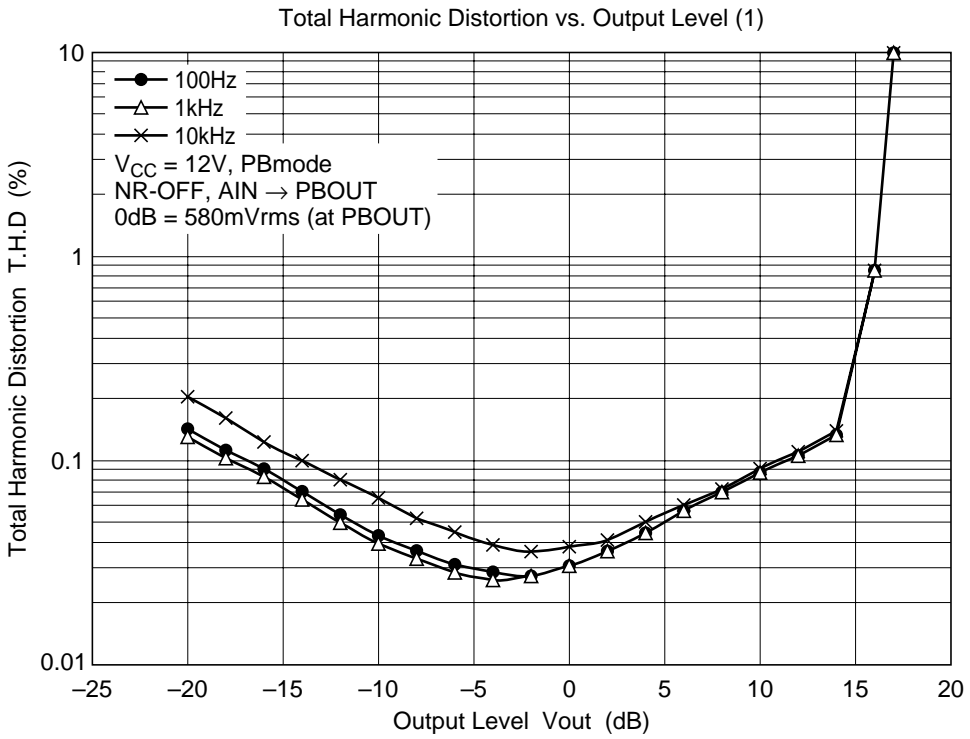

Total Harmonic Distortion vs. Output Level (3)

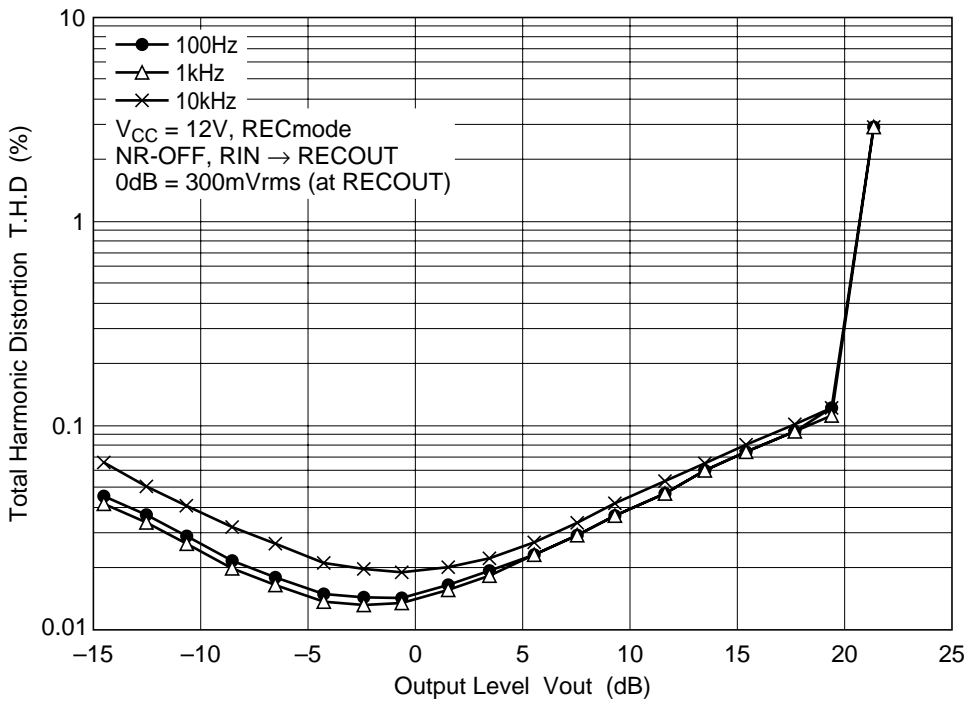

Total Harmonic Distortion vs. Output Level (4)

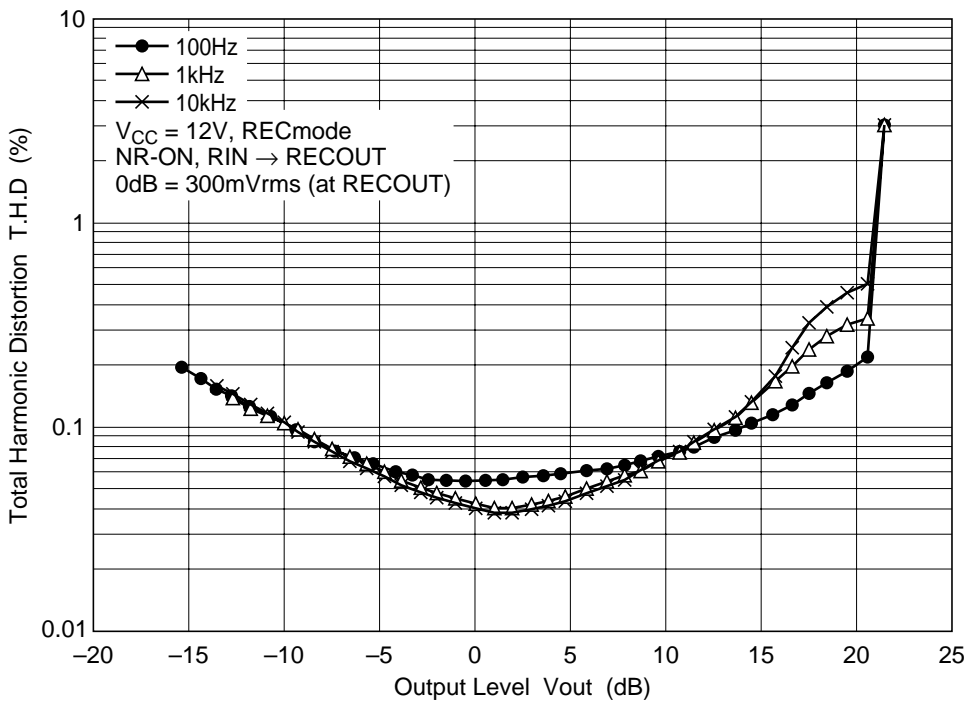

Total Harmonic Distortion vs. Frequency (1)

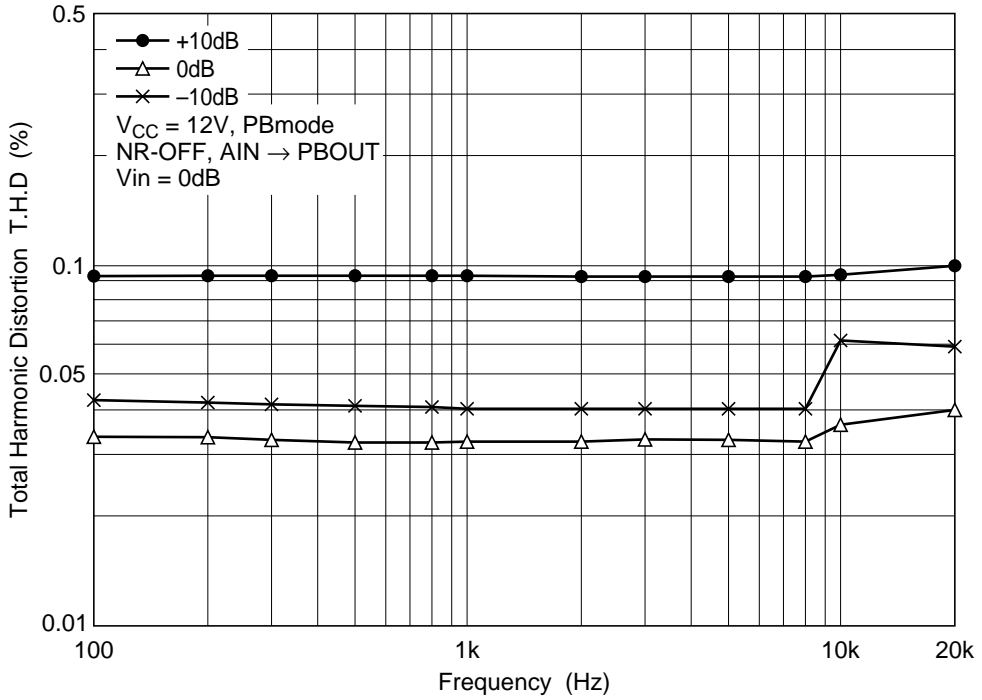

Total Harmonic Distortion vs. Frequency (2)

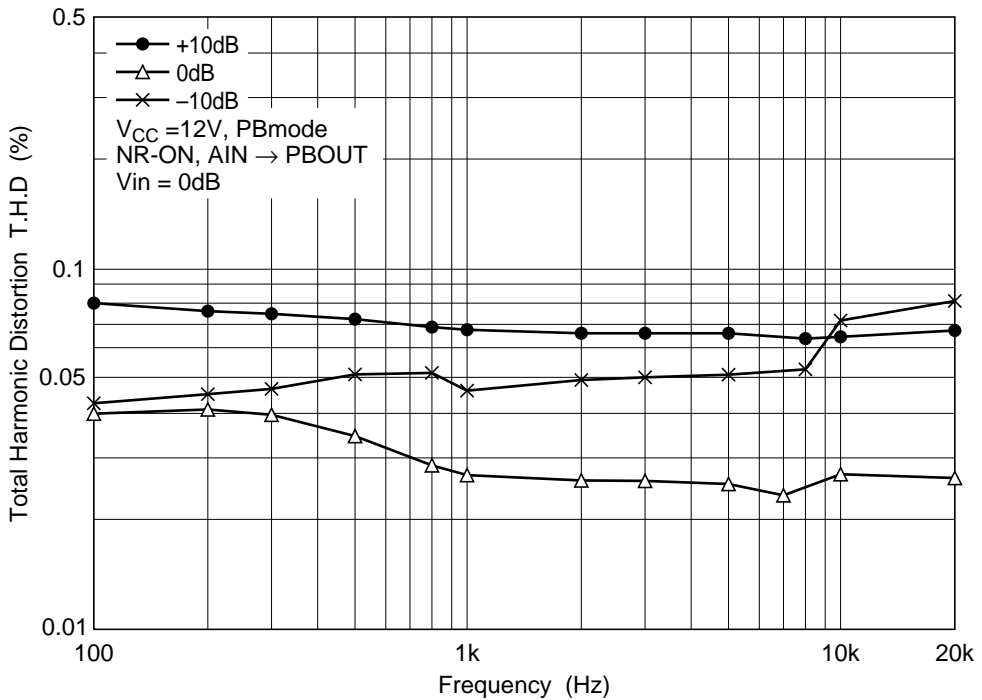

Total Harmonic Distortion vs. Frequency (3)

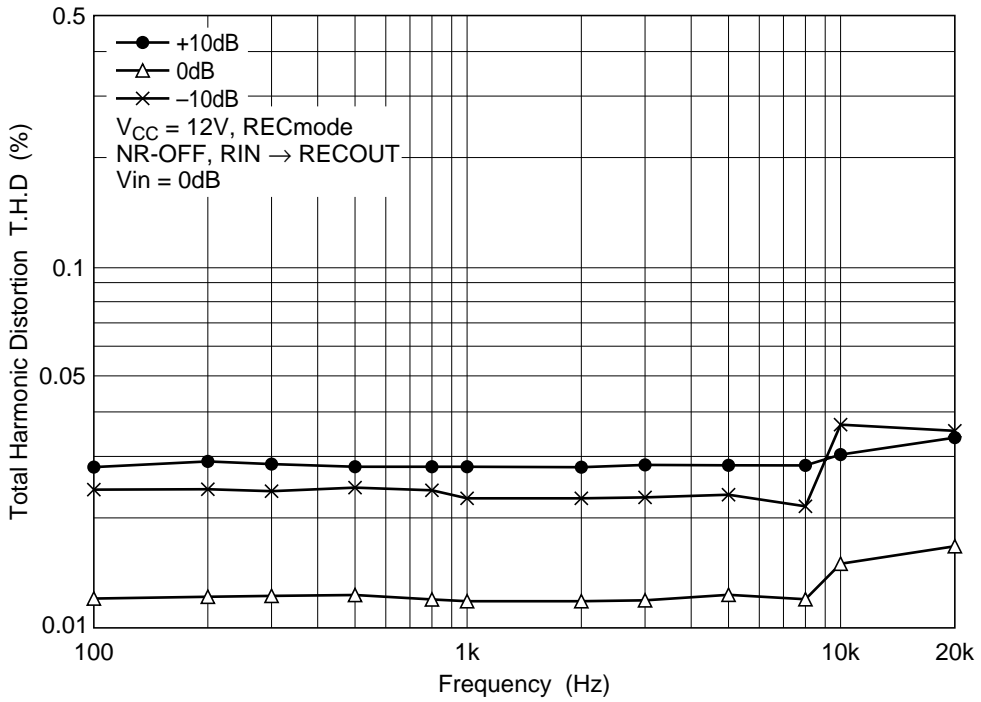

Total Harmonic Distortion vs. Frequency (4)

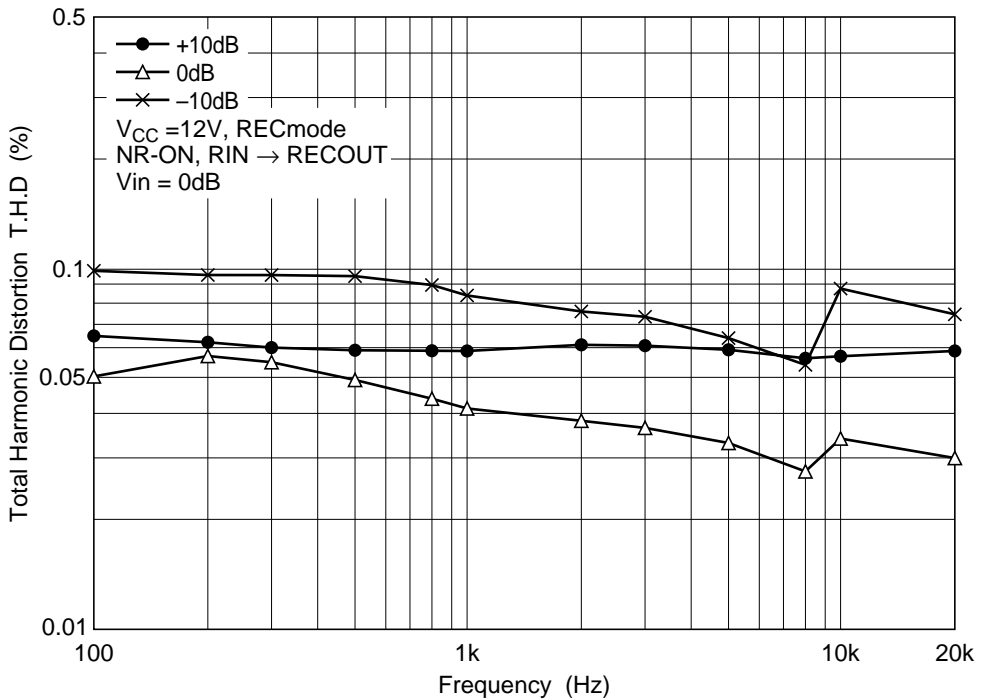

Crosstalk vs. Frequency (1)

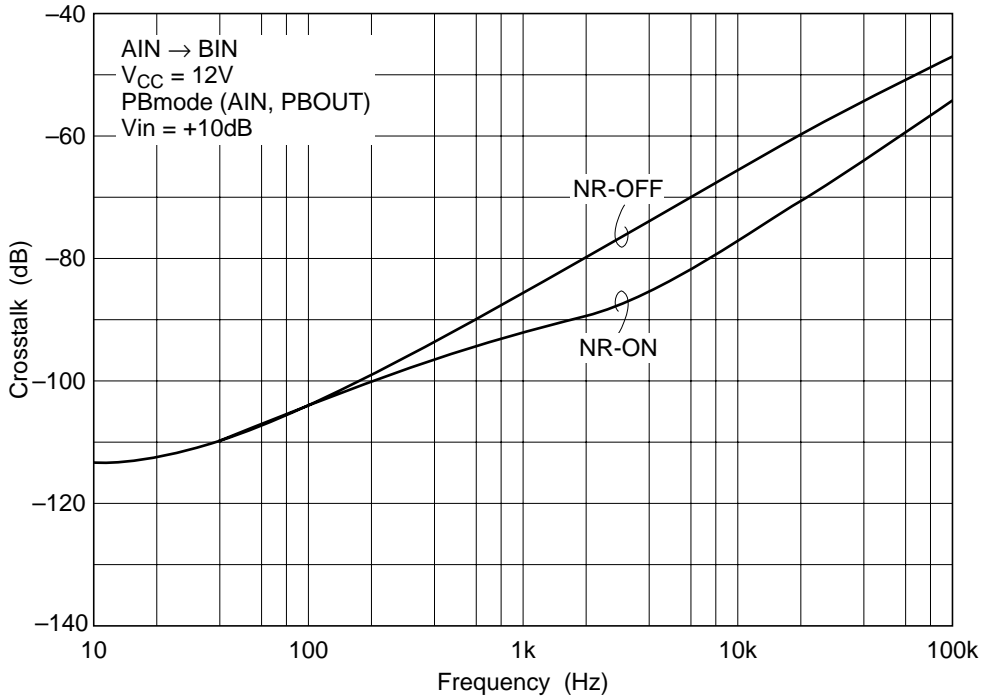

Crosstalk vs. Frequency (2)

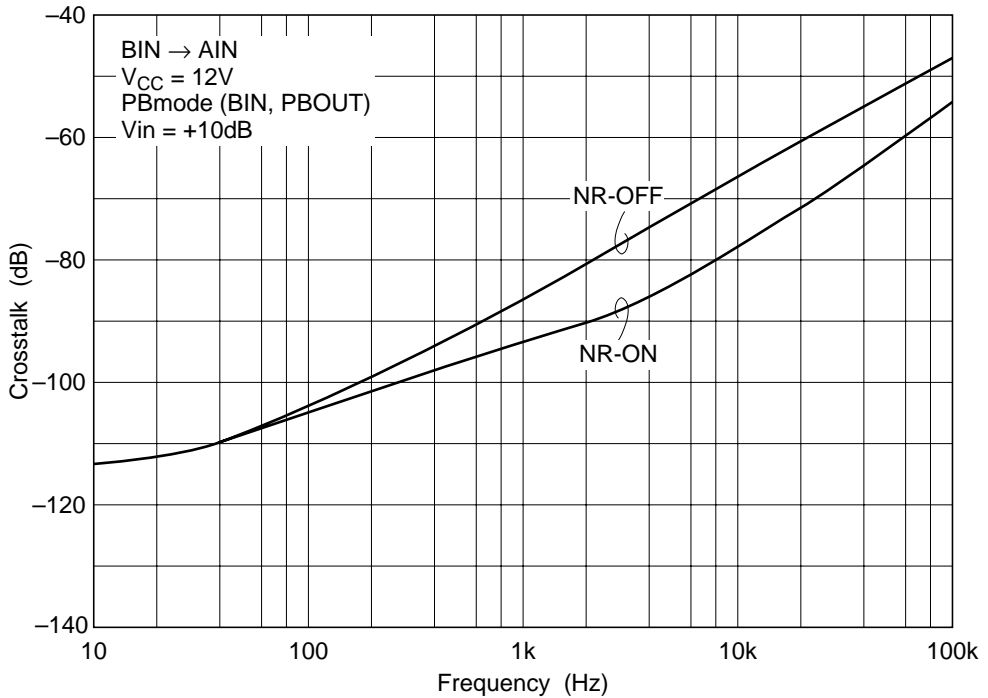

Crosstalk vs. Frequency (3)

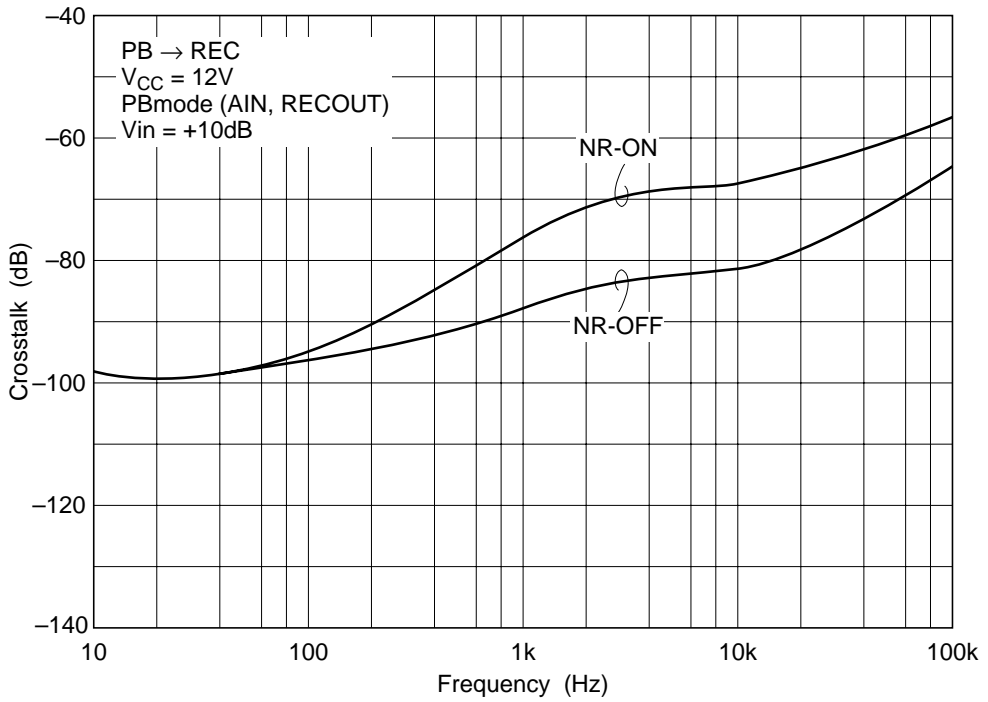

Crosstalk vs. Frequency (4)

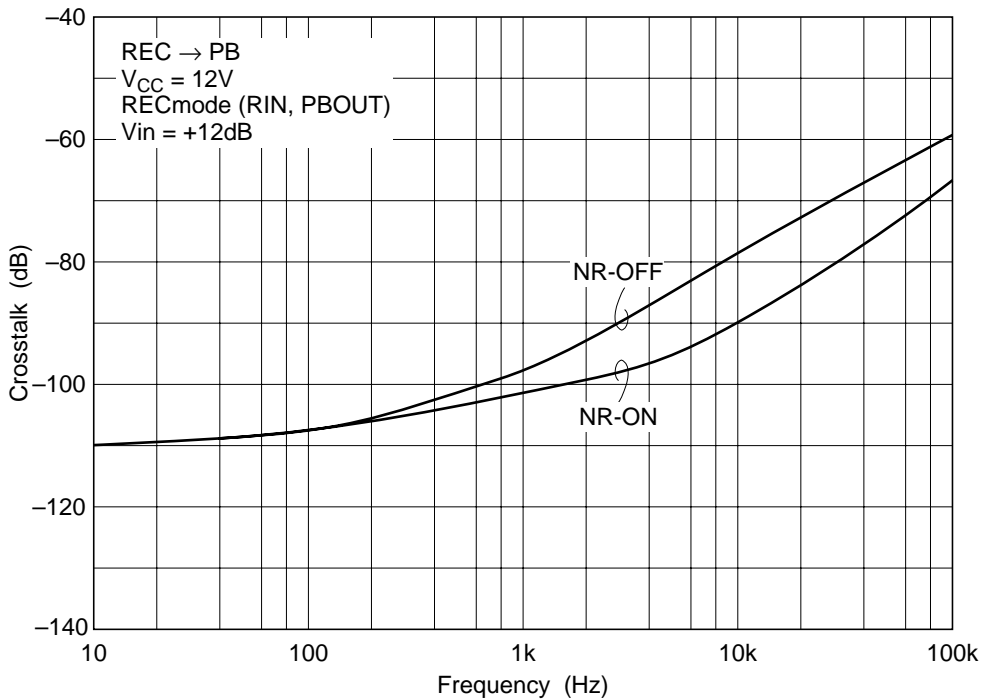

Channel Separation vs. Frequency (1)

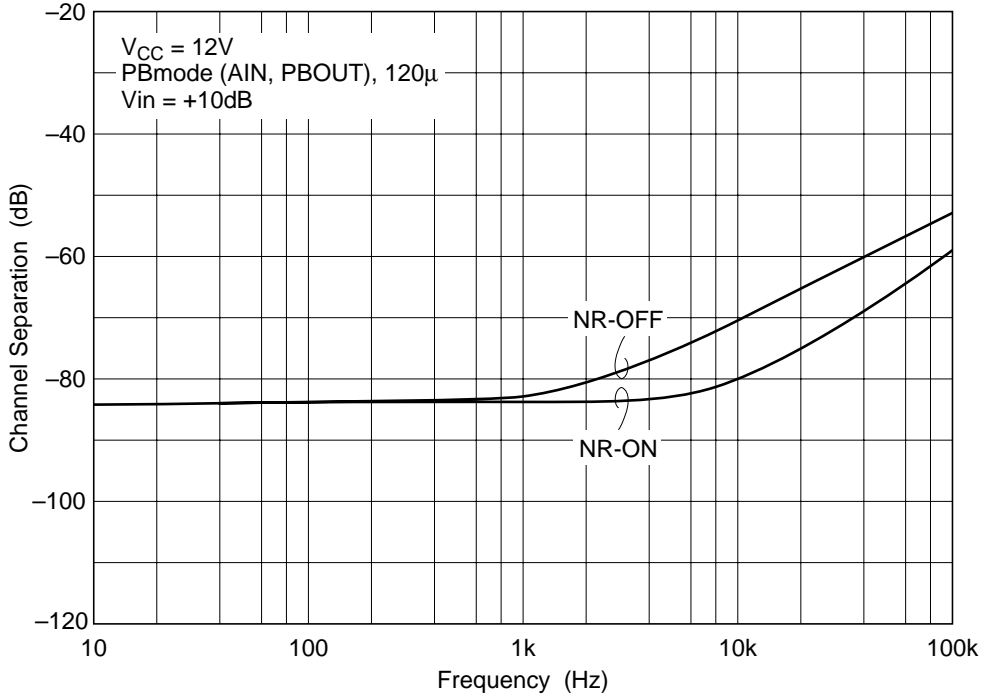

Channel Separation vs. Frequency (2)

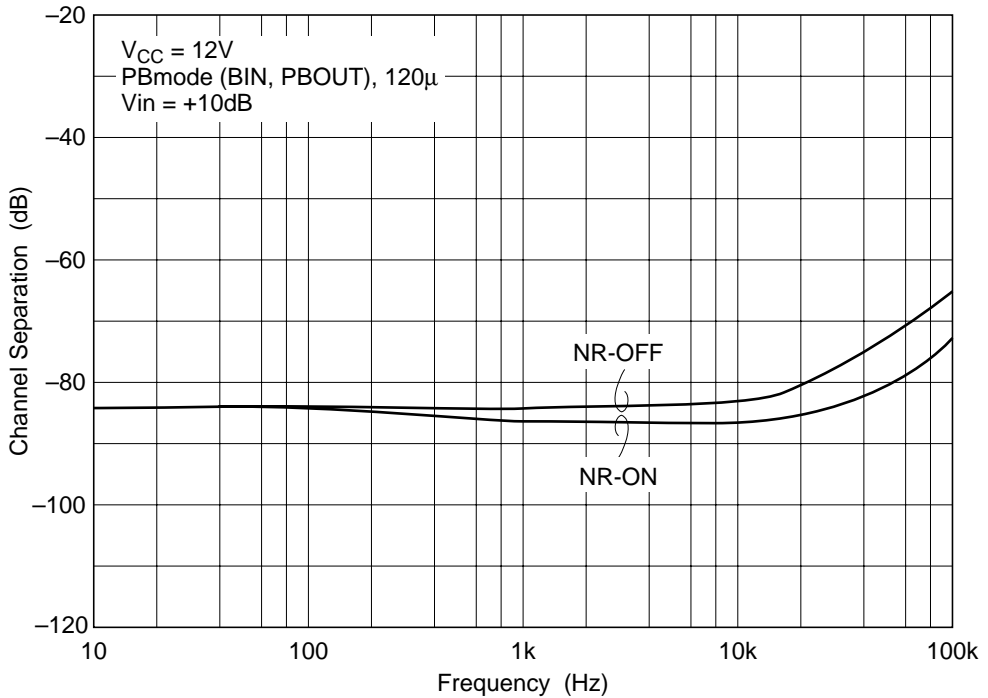

Channel Separation vs. Frequency (3)

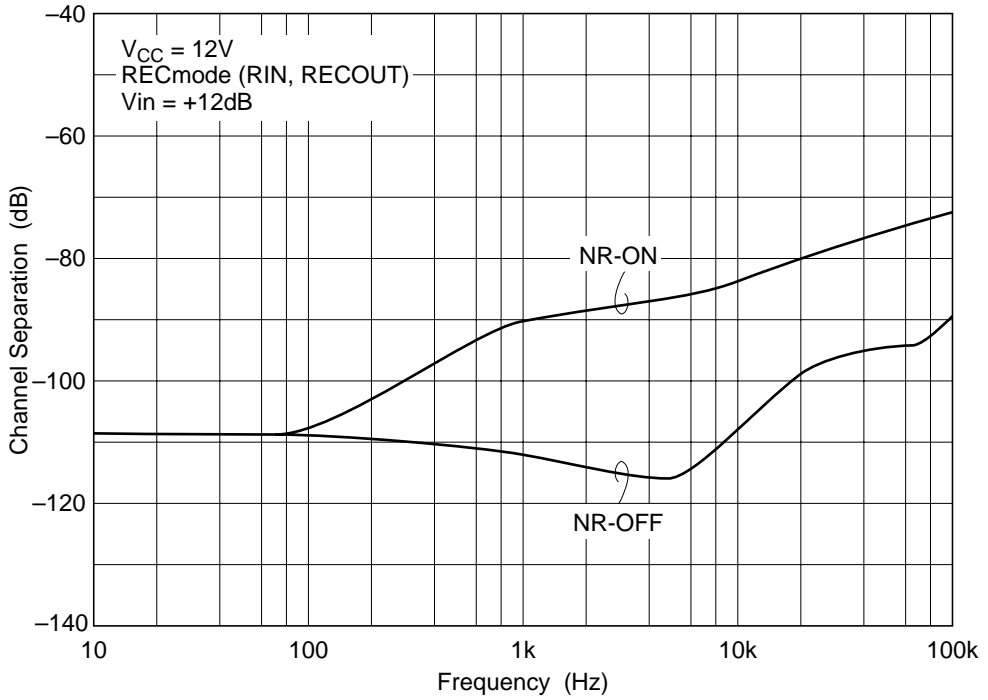

LINE-MUTE Attenuation vs. Frequency (1)

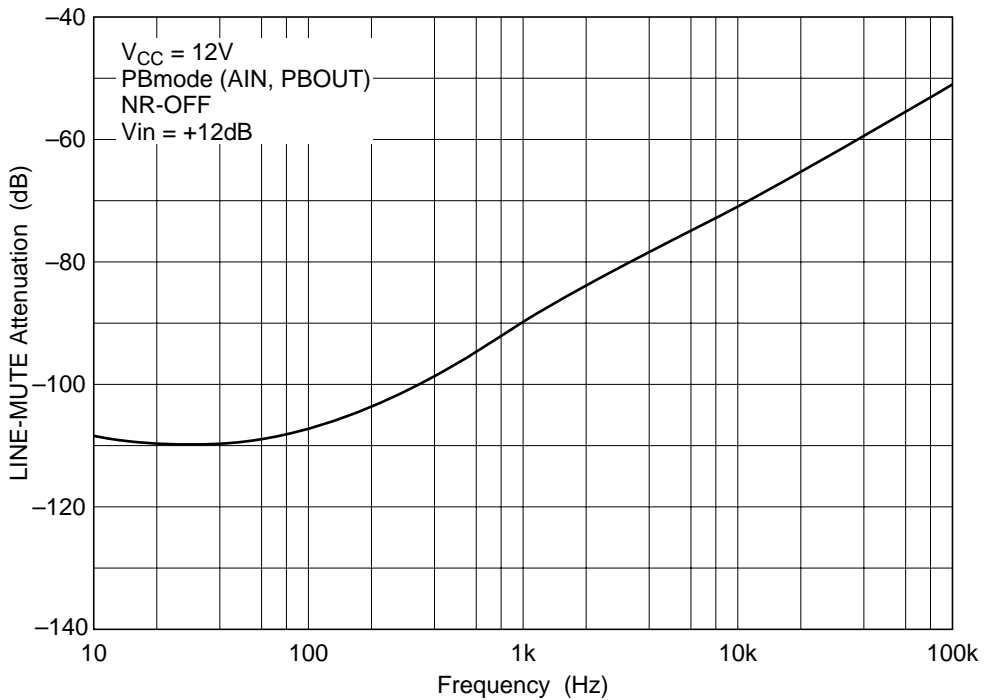

LINE-MUTE Attenuation vs. Frequency (2)

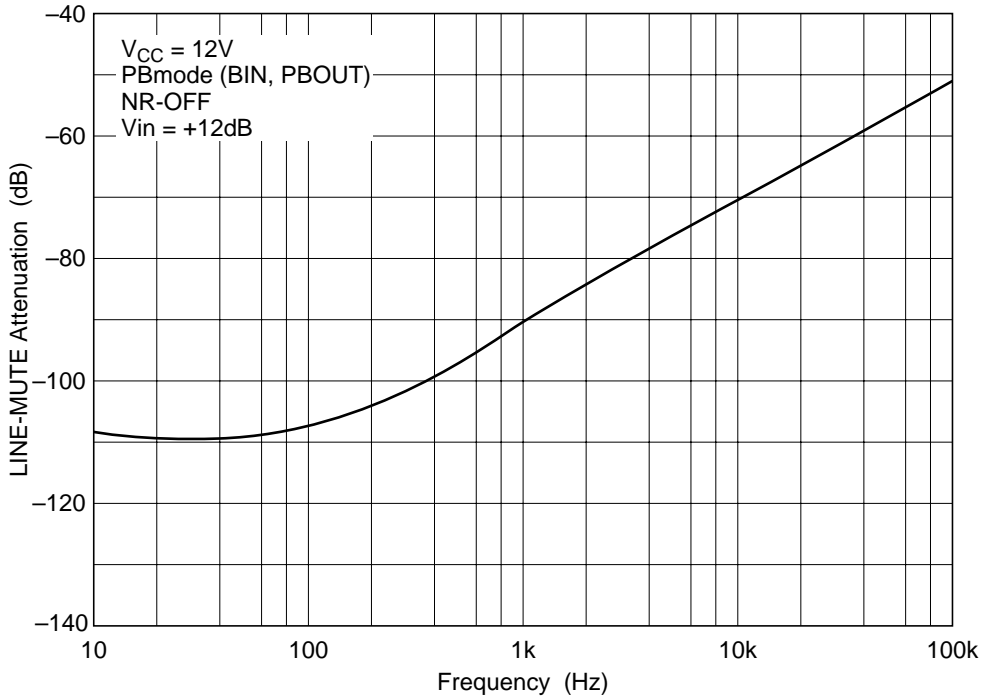

LINE-MUTE Attenuation vs. Frequency (3)

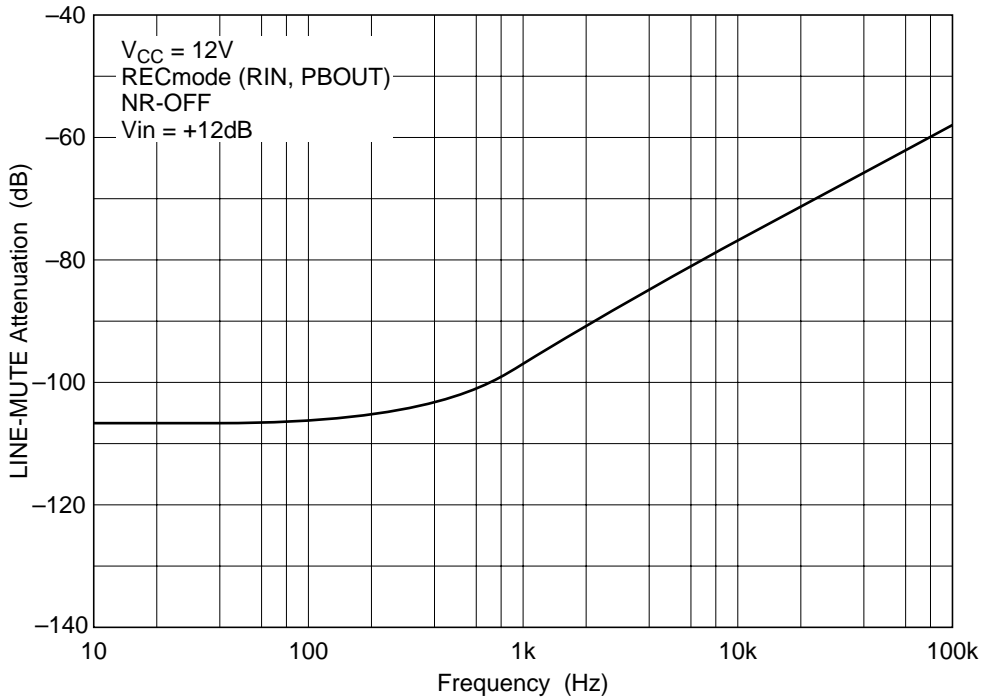

Ripple Rejection Ratio vs. Frequency (1)

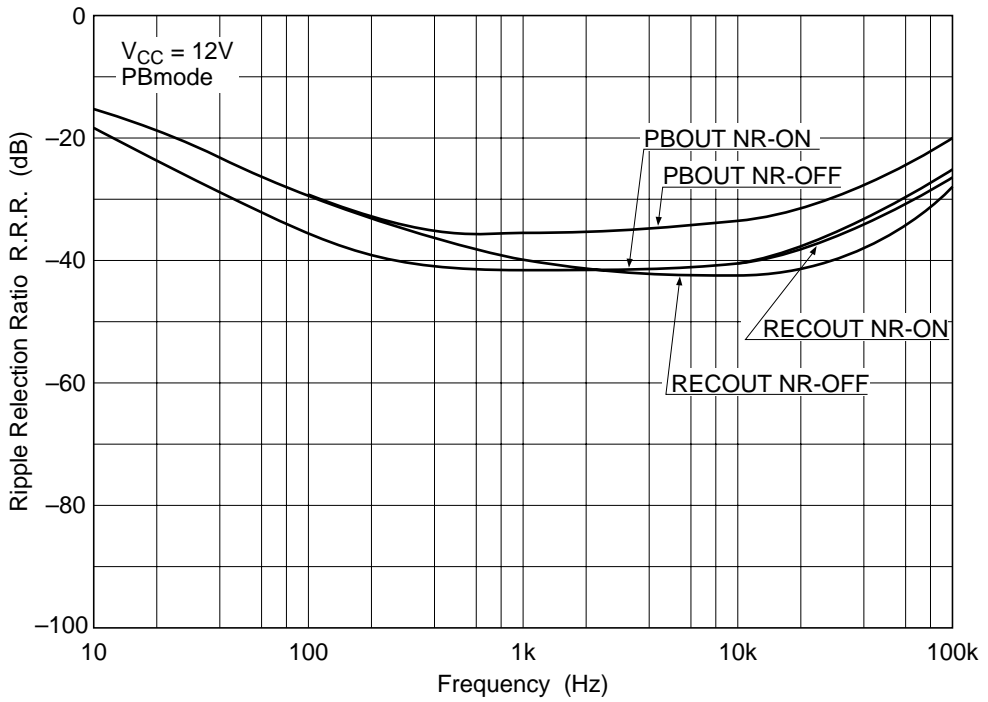

Ripple Rejection Ratio vs. Frequency (2)

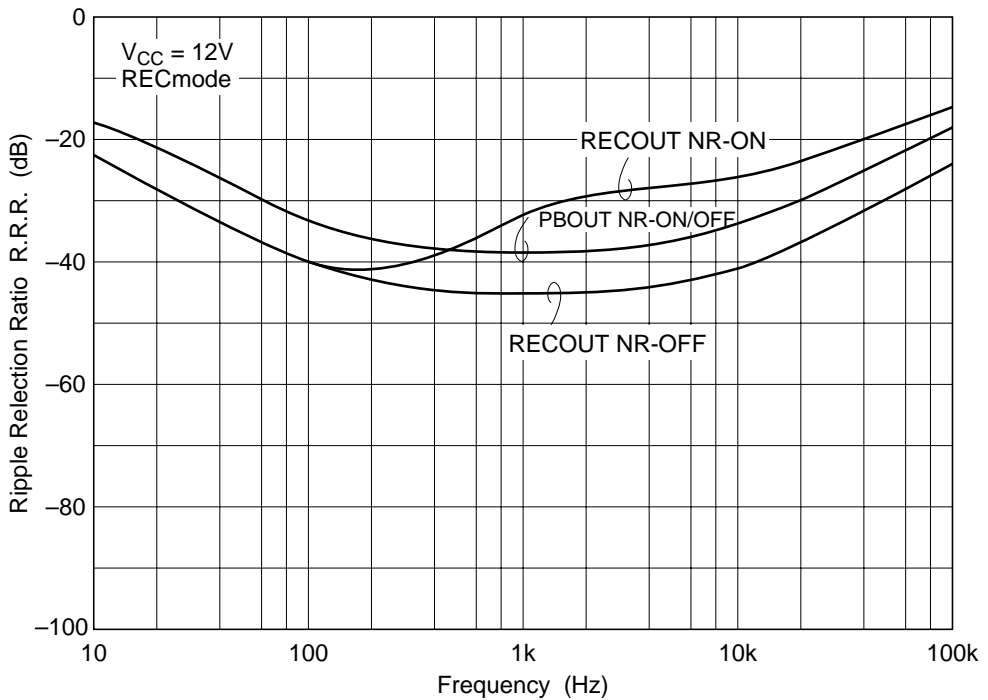

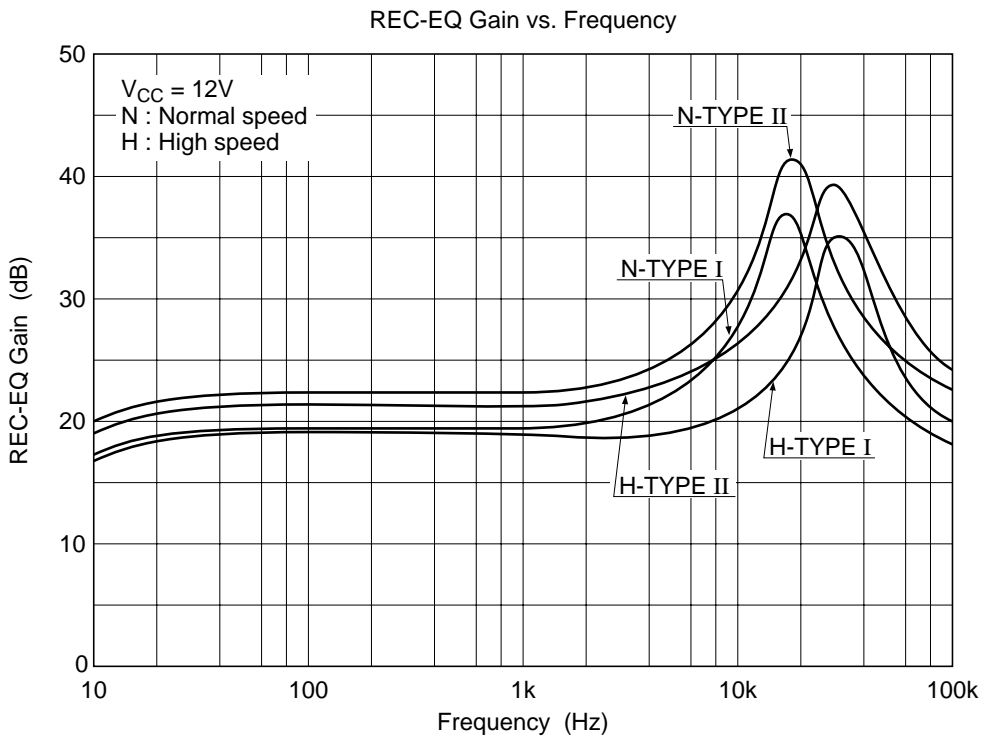
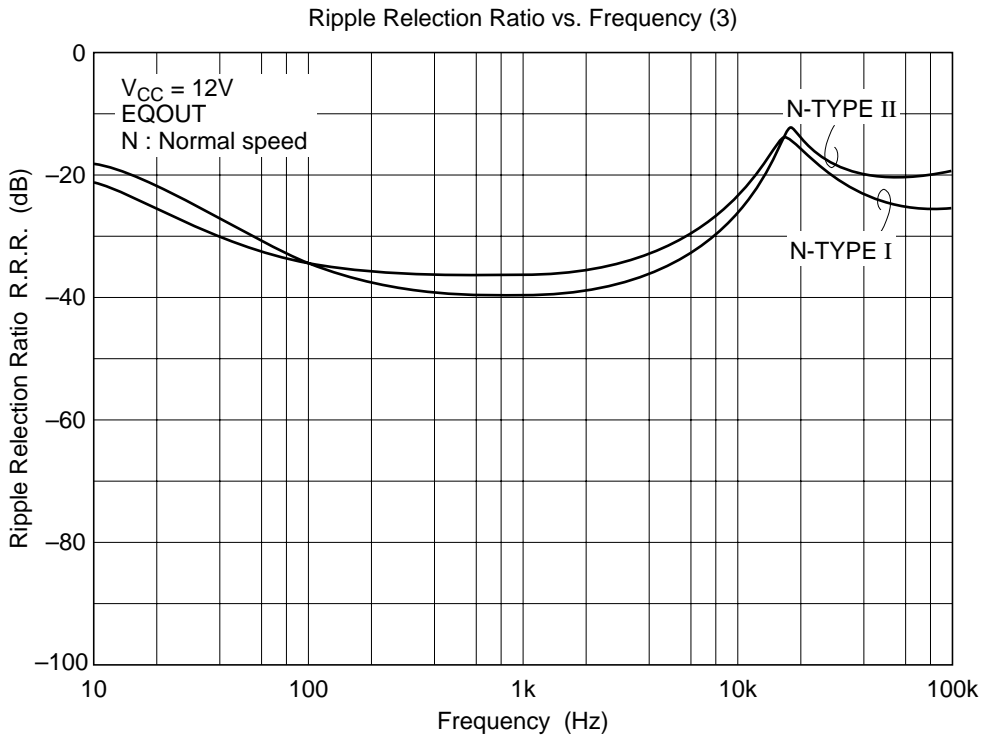

EQ Maximum Input Level vs. Supply Voltage (1)

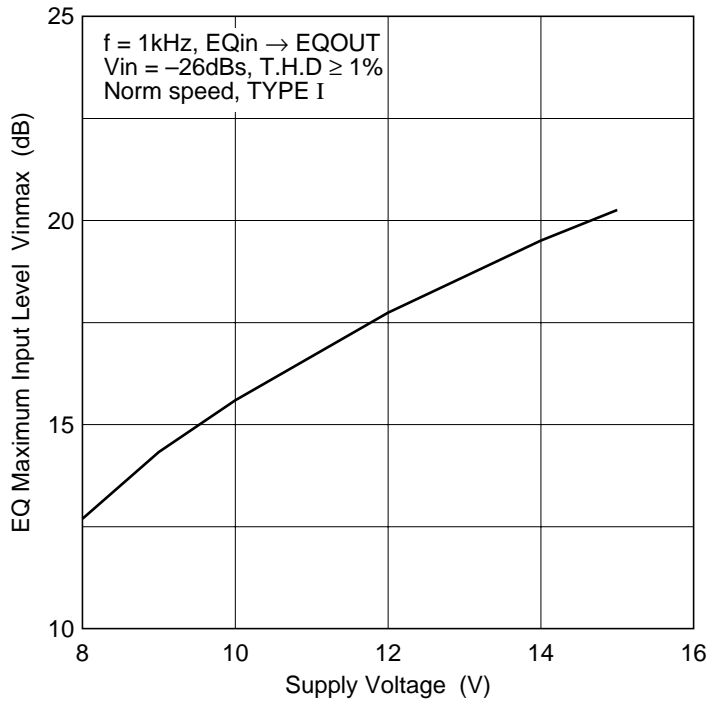

EQ Maximum Input Level vs. Supply Voltage (2)

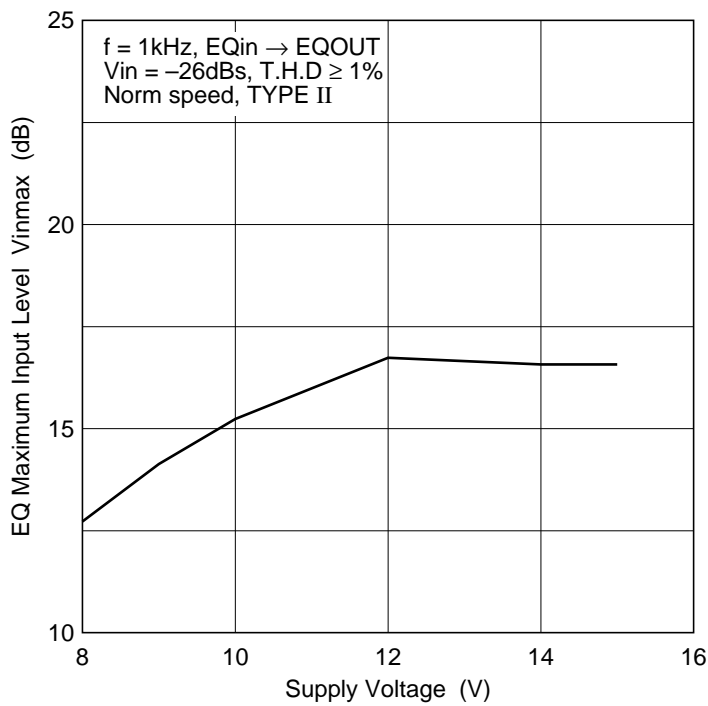

EQ Maximum Input Level vs. Supply Voltage (3)

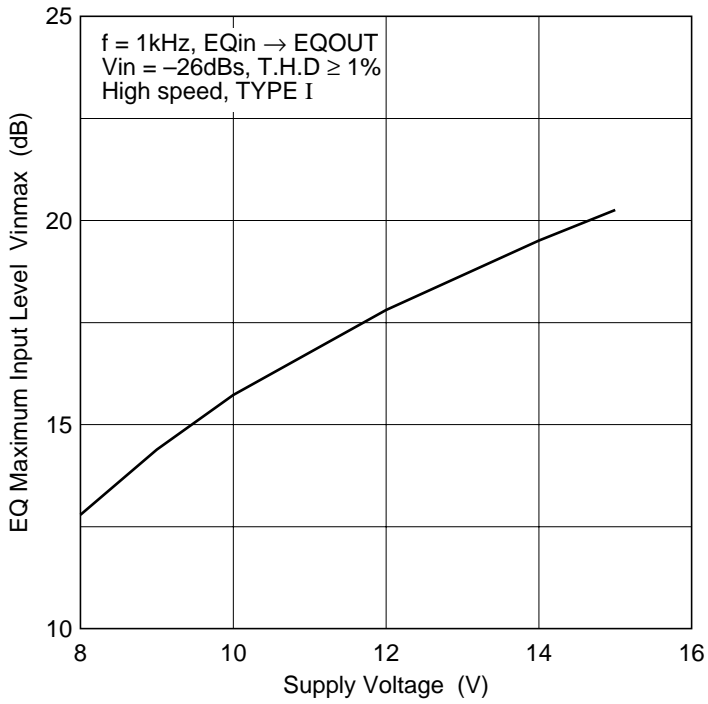

EQ Maximum Input Level vs. Supply Voltage (4)

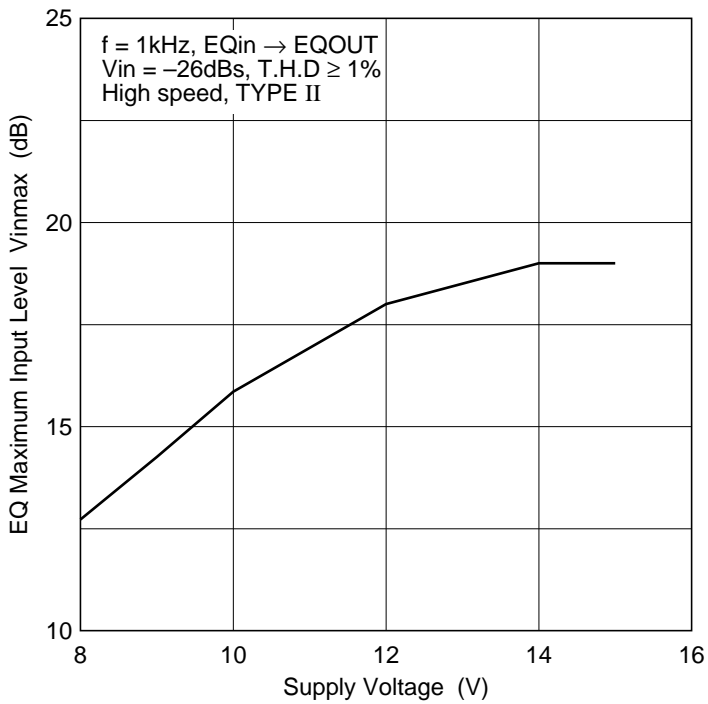

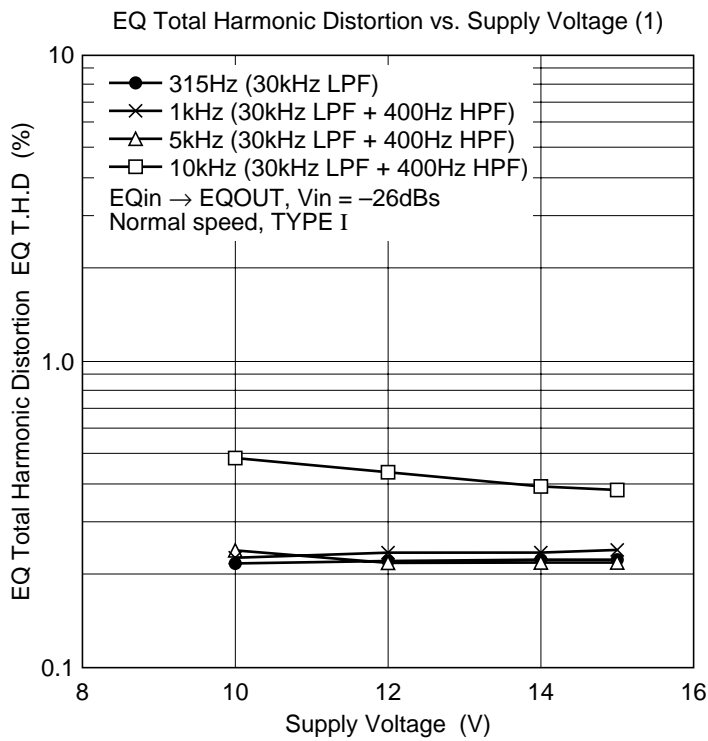
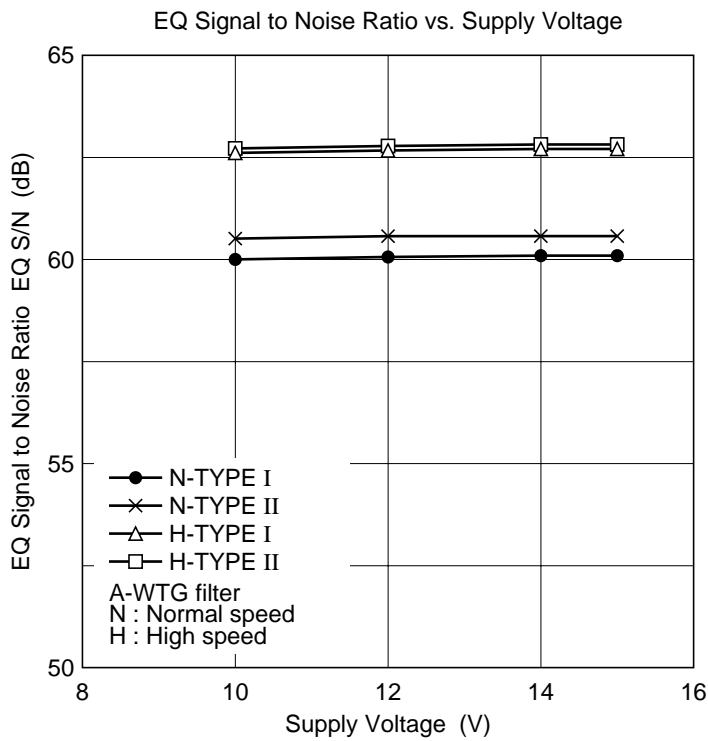

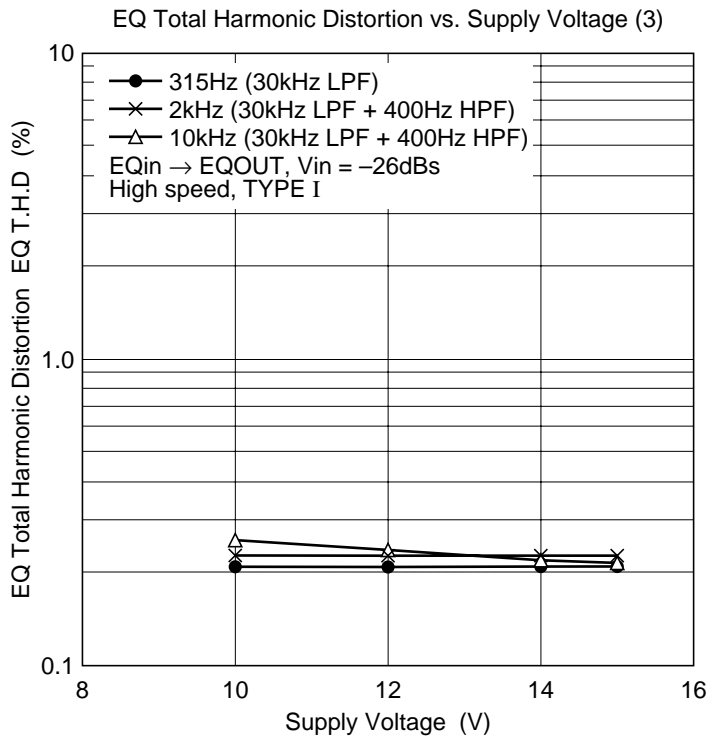
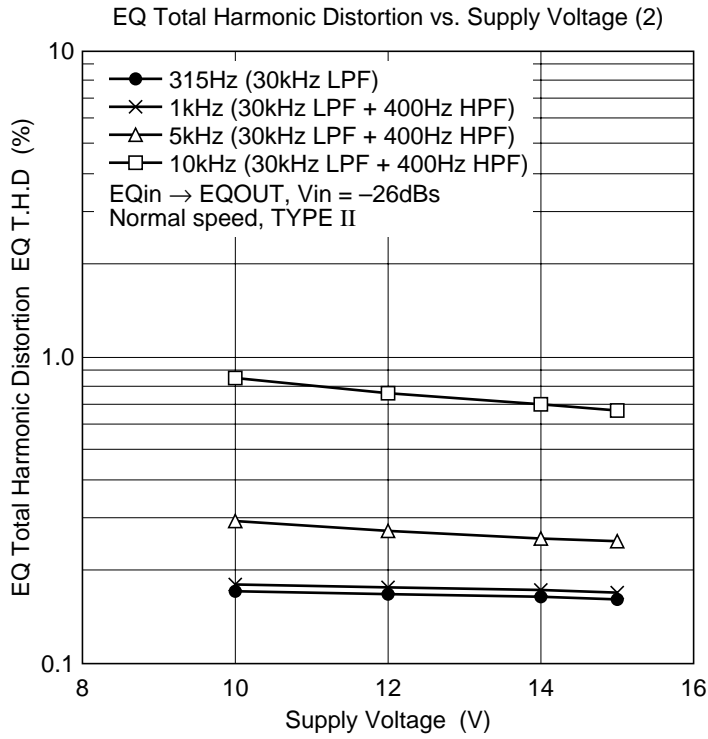

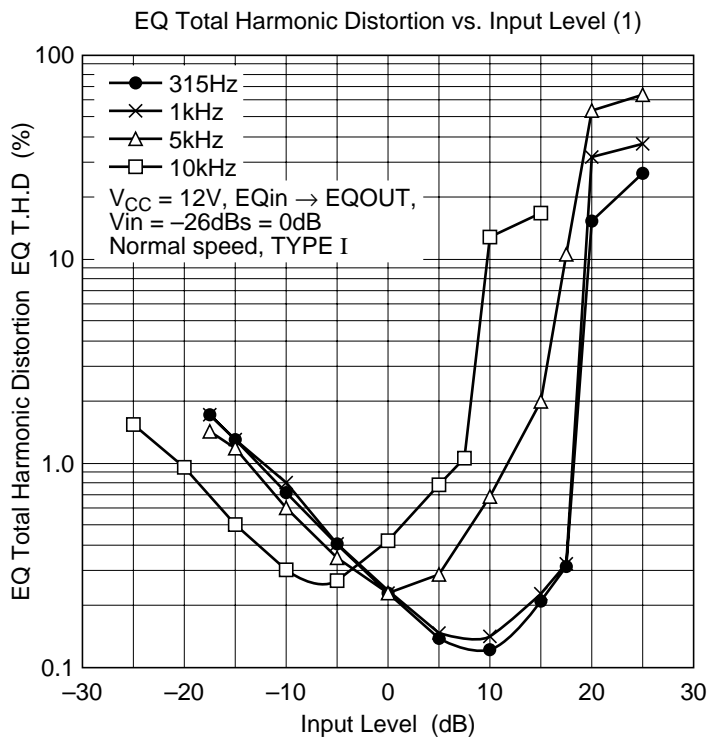
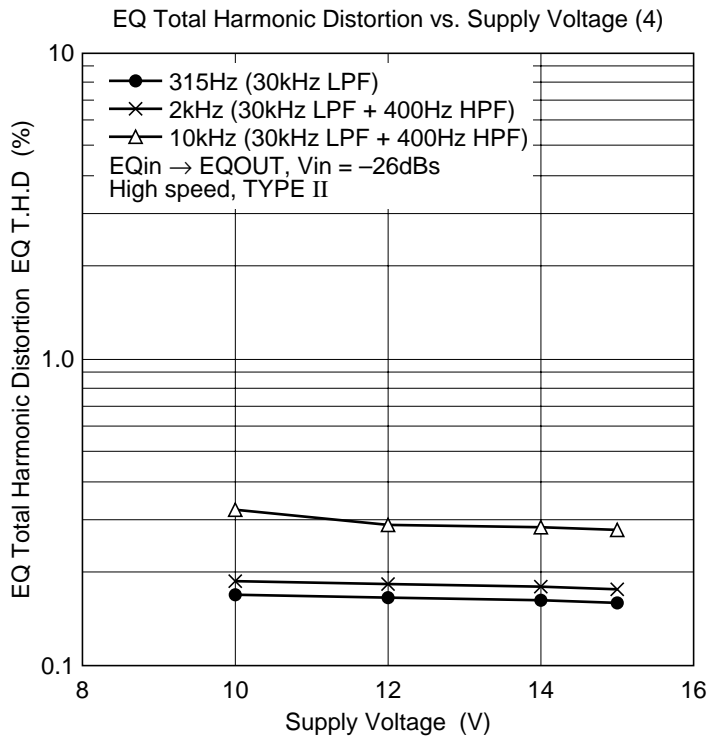

EQ Total Harmonic Distortion vs. Input Level (2)

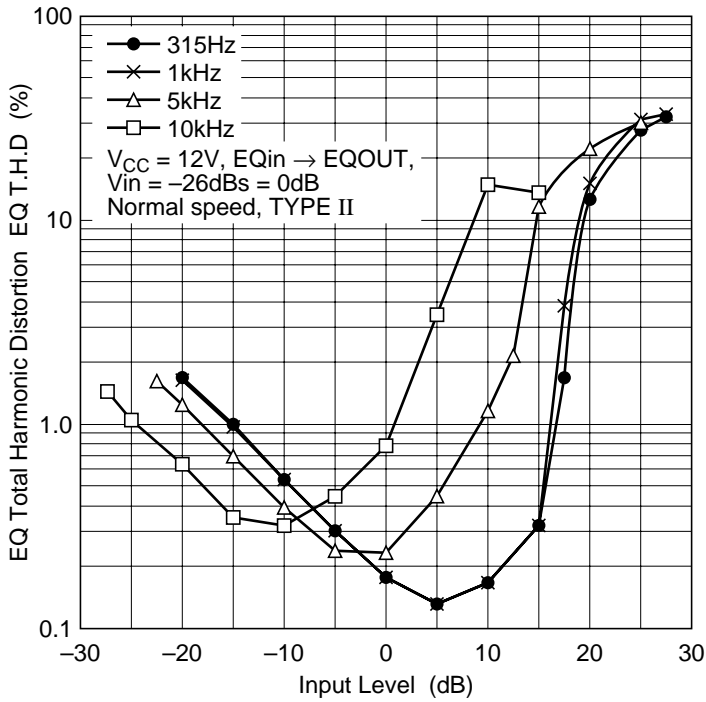

EQ Total Harmonic Distortion vs. Input Level (3)

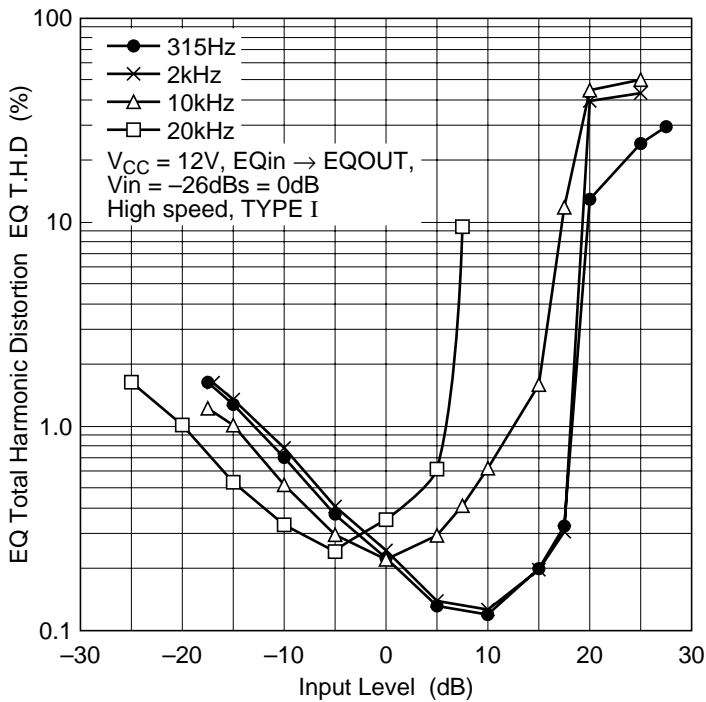

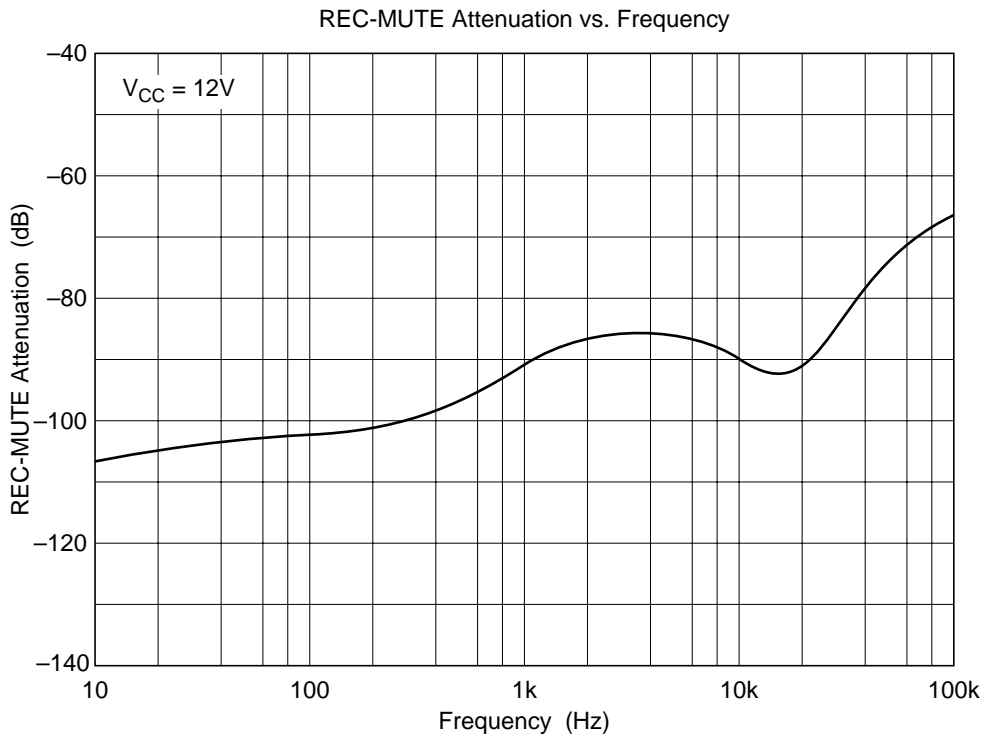
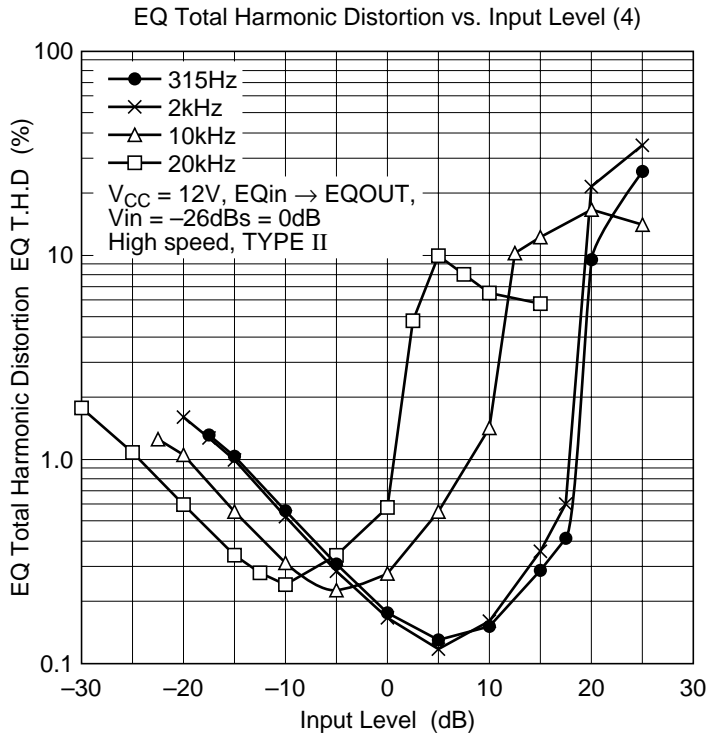

MS AMP. Gain vs. Frequency

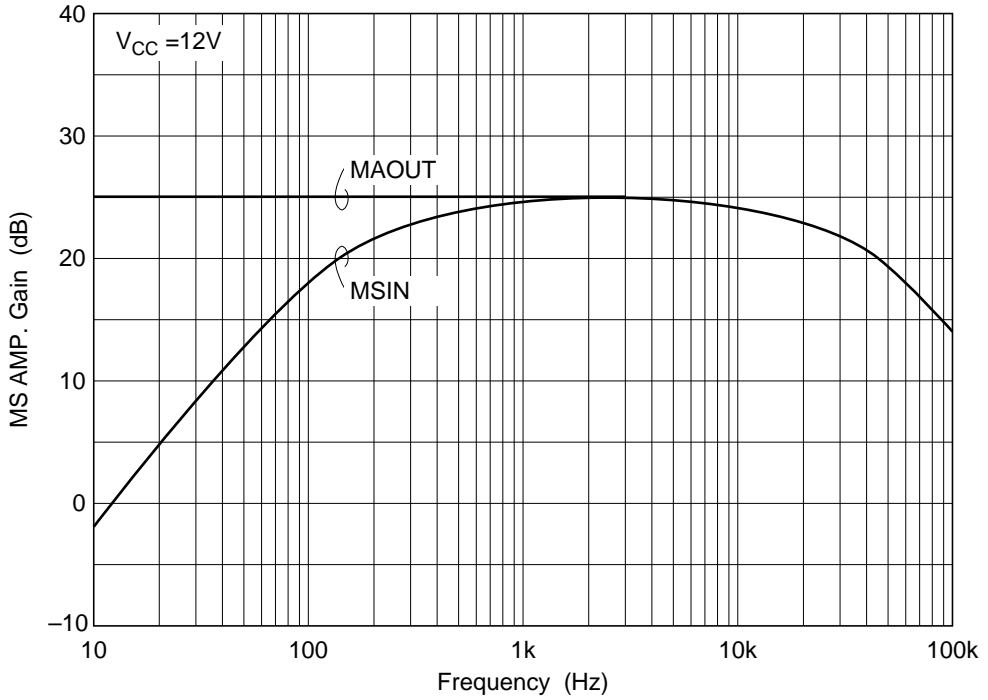

MS Sensitivity vs. Frequency

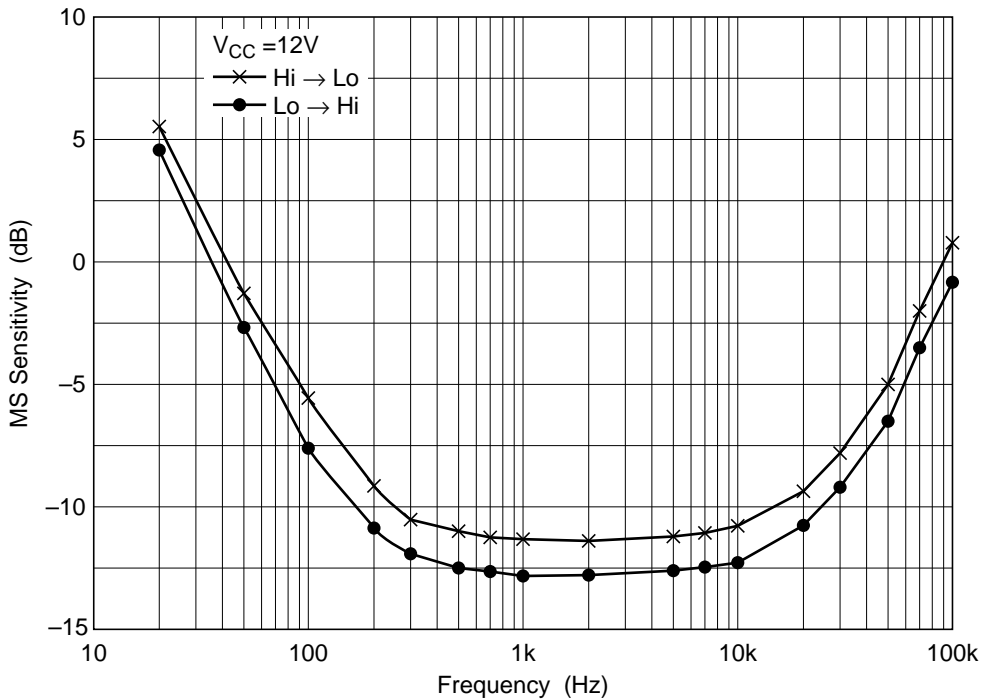

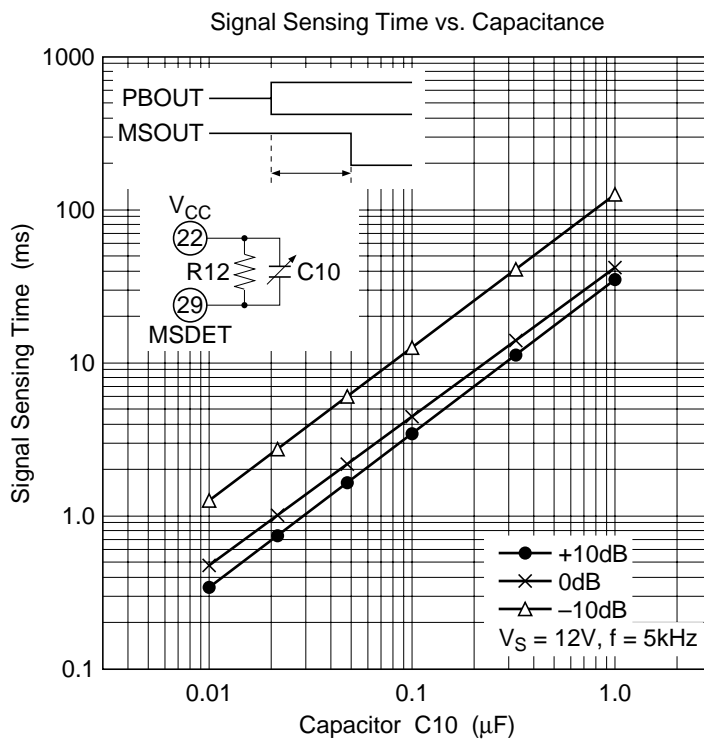
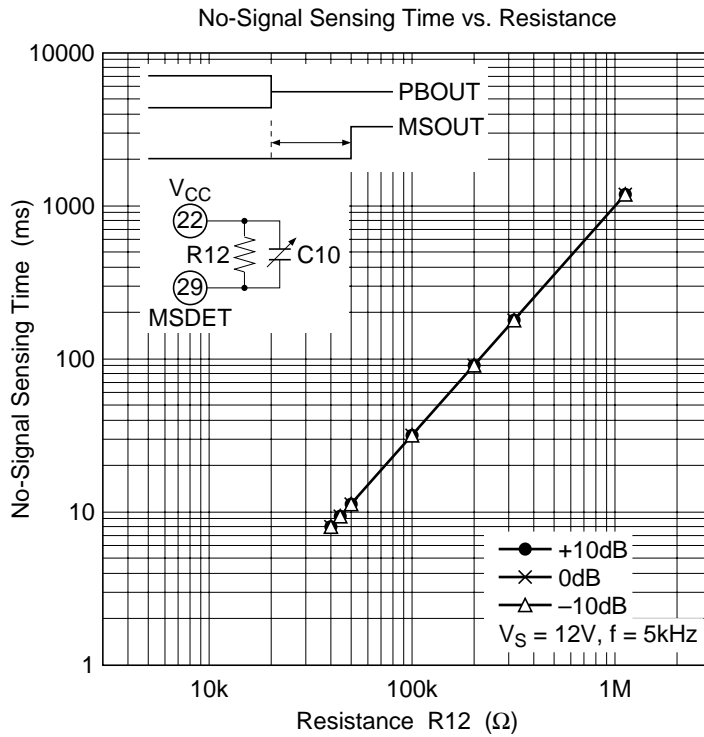

HA12209F

Package Dimensions

Unit: mm

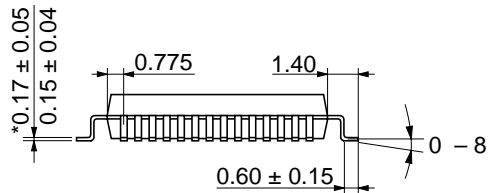
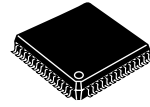
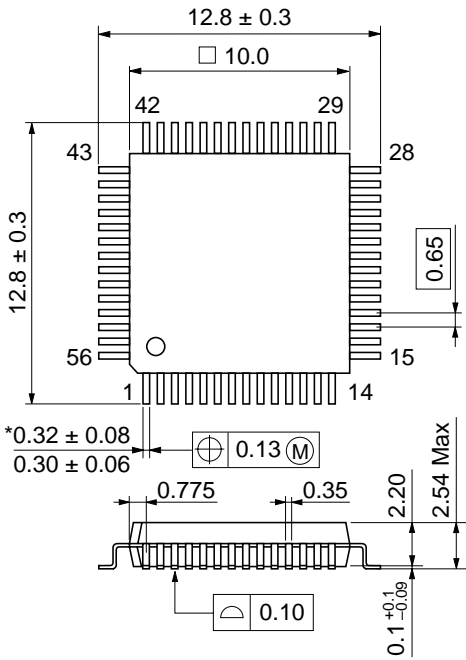

*Dimension including the plating thickness
Base material dimension

Hitachi Code	FP-56
JEDEC	—
EIAJ	—
Weight (reference value)	0.5 g

Disclaimer

1. Hitachi neither warrants nor grants licenses of any rights of Hitachi's or any third party's patent, copyright, trademark, or other intellectual property rights for information contained in this document. Hitachi bears no responsibility for problems that may arise with third party's rights, including intellectual property rights, in connection with use of the information contained in this document.
2. Products and product specifications may be subject to change without notice. Confirm that you have received the latest product standards or specifications before final design, purchase or use.
3. Hitachi makes every attempt to ensure that its products are of high quality and reliability. However, contact Hitachi's sales office before using the product in an application that demands especially high quality and reliability or where its failure or malfunction may directly threaten human life or cause risk of bodily injury, such as aerospace, aeronautics, nuclear power, combustion control, transportation, traffic, safety equipment or medical equipment for life support.
4. Design your application so that the product is used within the ranges guaranteed by Hitachi particularly for maximum rating, operating supply voltage range, heat radiation characteristics, installation conditions and other characteristics. Hitachi bears no responsibility for failure or damage when used beyond the guaranteed ranges. Even within the guaranteed ranges, consider normally foreseeable failure rates or failure modes in semiconductor devices and employ systemic measures such as fail-safes, so that the equipment incorporating Hitachi product does not cause bodily injury, fire or other consequential damage due to operation of the Hitachi product.
5. This product is not designed to be radiation resistant.
6. No one is permitted to reproduce or duplicate, in any form, the whole or part of this document without written approval from Hitachi.
7. Contact Hitachi's sales office for any questions regarding this document or Hitachi semiconductor products.

Sales Offices

HITACHI

Hitachi, Ltd.

Semiconductor & Integrated Circuits.
Nippon Bldg., 2-6-2, Ohte-machi, Chiyoda-ku, Tokyo 100-0004, Japan
Tel: Tokyo (03) 3270-2111 Fax: (03) 3270-5109

URL NorthAmerica : <http://semiconductor.hitachi.com/>
 Europe : <http://www.hitachi-eu.com/hel/ecg>
 Asia : <http://sicapac.hitachi-asia.com>
 Japan : <http://www.hitachi.co.jp/Sicd/indx.htm>

For further information write to:

Hitachi Semiconductor
(America) Inc.
179 East Tasman Drive,
San Jose, CA 95134
Tel: <1>(408) 433-1990
Fax: <1>(408) 433-0223

Hitachi Europe GmbH
Electronic Components Group
Dornacher Straße 3
D-85622 Feldkirchen, Munich
Germany
Tel: <49> (89) 9 9180-0
Fax: <49> (89) 9 29 30 00

Hitachi Europe Ltd.
Electronic Components Group.
Whitebrook Park
Lower Cookham Road
Maidenhead
Berkshire SL6 8YA, United Kingdom
Tel: <44> (1628) 585000
Fax: <44> (1628) 585160

Hitachi Asia Ltd.
Hitachi Tower
16 Collyer Quay #20-00,
Singapore 049318
Tel : <65>-538-6533/538-8577
Fax : <65>-538-6933/538-3877
URL : <http://www.hitachi.com.sg>

Hitachi Asia Ltd.
(Taipei Branch Office)
4/F, No. 167, Tun Hwa North Road,
Hung-Kuo Building,
Taipei (105), Taiwan
Tel : <886>-(2)-2718-3666
Fax : <886>-(2)-2718-8180
Telex : 23222 HAS-TP
URL : <http://www.hitachi.com.tw>

Hitachi Asia (Hong Kong) Ltd.
Group III (Electronic Components)
7/F., North Tower,
World Finance Centre,
Harbour City, Canton Road
Tsim Sha Tsui, Kowloon,
Hong Kong
Tel : <852>-(2)-735-9218
Fax : <852>-(2)-730-0281
URL : <http://www.hitachi.com.hk>

Copyright © Hitachi, Ltd., 2000. All rights reserved. Printed in Japan.
Colophon 2.0