

DATA SHEET

For a complete data sheet, please also download:

- The IC04 LOCMOS HE4000B Logic Family Specifications HEF, HEC
- The IC04 LOCMOS HE4000B Logic Package Outlines/Information HEF, HEC

HEF40160B

MSI

4-bit synchronous decade counter
with asynchronous reset

Product specification
File under Integrated Circuits, IC04

January 1995

4-bit synchronous decade counter with asynchronous reset

**HEF40160B
MSI**

DESCRIPTION

The HEF40160B is a fully synchronous edge-triggered 4-bit decade counter with a clock input (CP), an overriding asynchronous master reset (\overline{MR}), four parallel data inputs (P_0 to P_3), three synchronous mode control inputs (parallel enable (\overline{PE}), count enable parallel (CEP) and count enable trickle (CET)), buffered outputs from all four bit positions (O_0 to O_3) and a terminal count output (TC).

Operation is fully synchronous (except for the \overline{MR} input) and occurs on the LOW to HIGH transition of CP. When \overline{PE} is LOW, the next LOW to HIGH transition of CP loads data into the counter from P_0 to P_3 regardless of the levels of CEP and CET inputs.

When \overline{PE} is HIGH, the next LOW to HIGH transition of CP advances the counter to its next state only if both CEP and CET are HIGH; otherwise, no change occurs in the state of the counter. TC is HIGH when the state of the counter is 9 ($O_0 = O_3 = \text{HIGH}$, $O_1 = O_2 = \text{LOW}$) and when CET is HIGH. A LOW on \overline{MR} sets all outputs (O_0 to O_3 and TC) LOW, independent of the state of all other inputs.

Multistage synchronous counting is possible without additional components by using a carry look-ahead counting technique; in this case, TC is used to enable successive cascaded stages. CEP, CET and \overline{PE} must be stable only during the set-up time before the LOW to HIGH transition of CP.

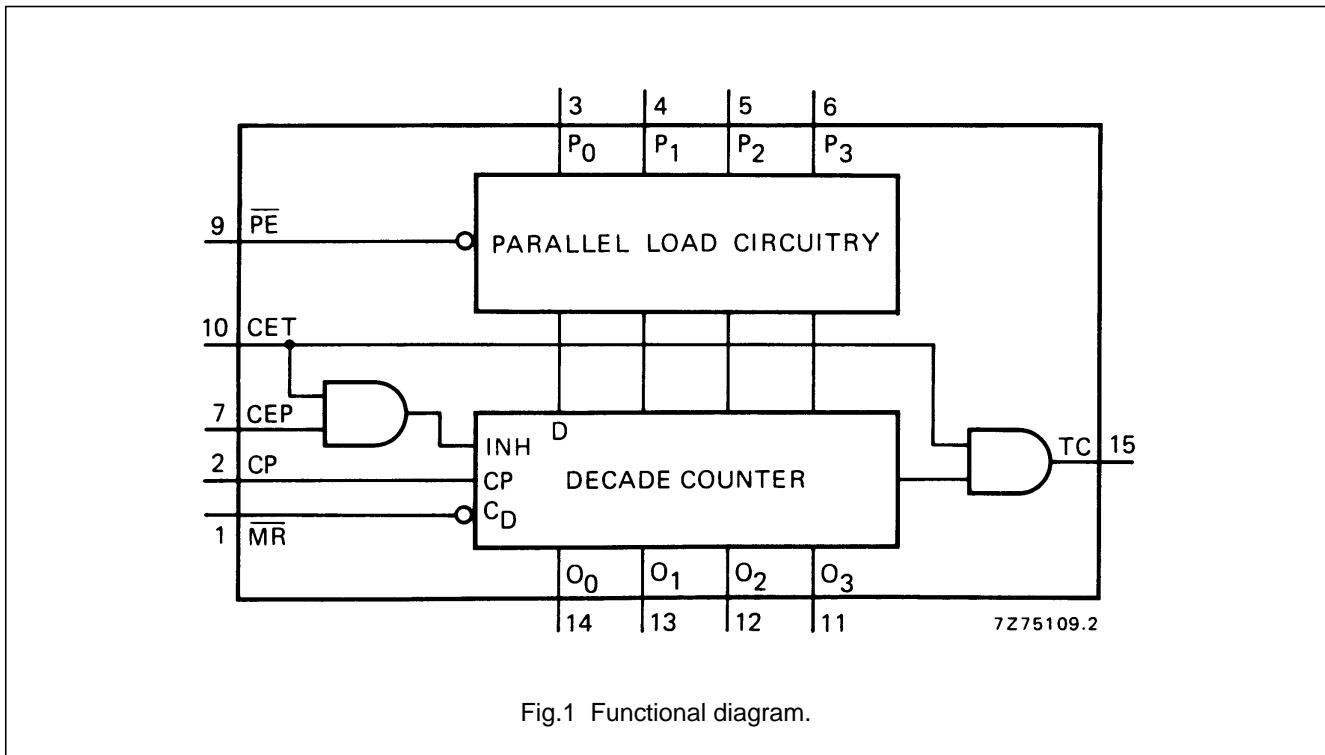

Fig.1 Functional diagram.

FAMILY DATA, I_{DD} LIMITS category MSI

See Family Specifications

4-bit synchronous decade counter with asynchronous reset

HEF40160B
MSI

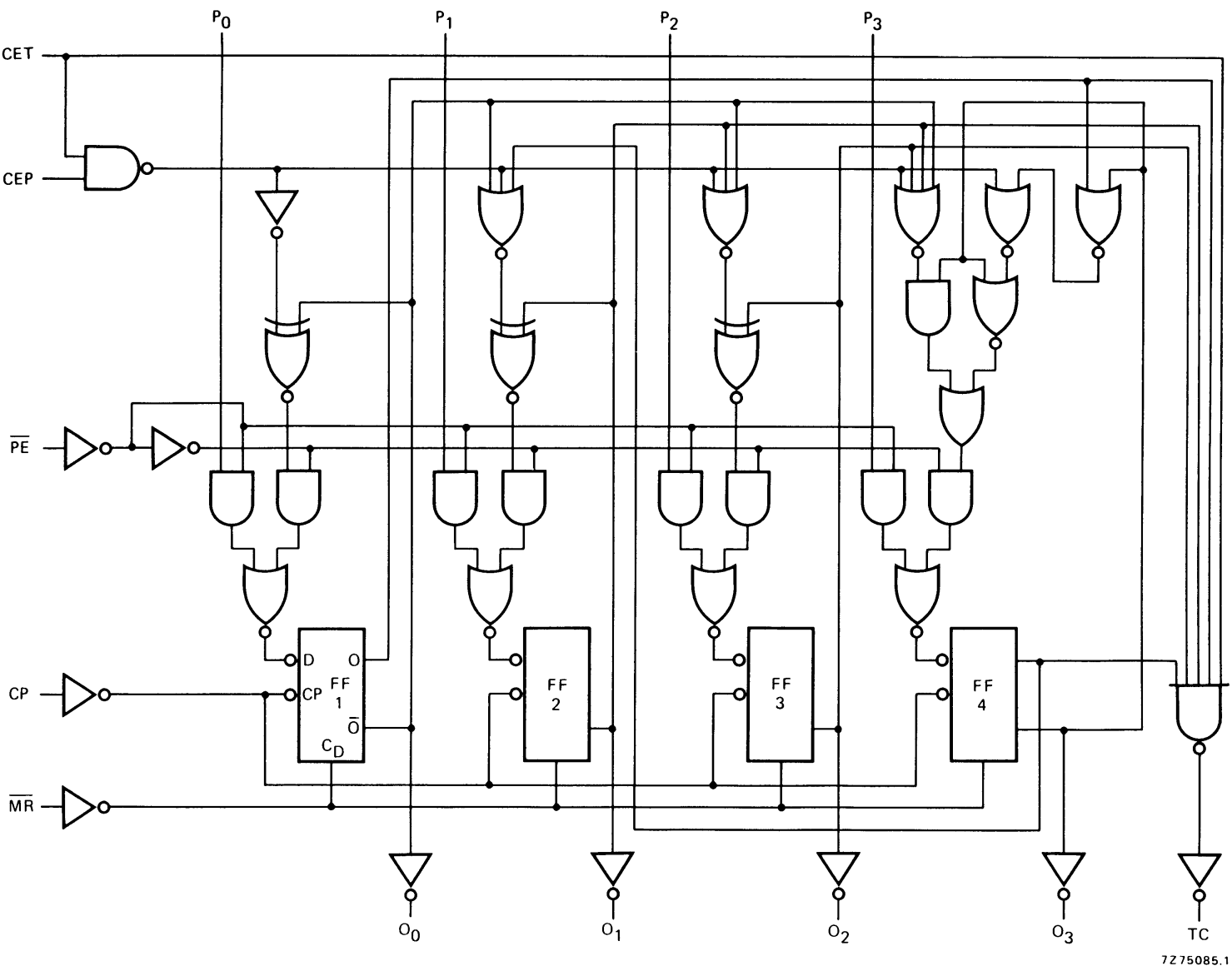
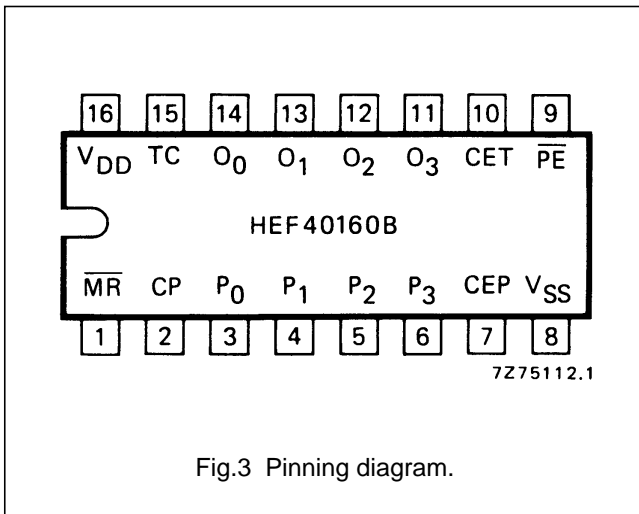

Fig.2 Logic diagram.

4-bit synchronous decade counter with asynchronous reset

HEF40160B
MSI



PINNING

- \overline{PE} parallel enable input
- P_0 to P_3 parallel data inputs
- CEP count enable parallel input
- CET count enable trickle input
- CP clock input (LOW to HIGH, edge-triggered)
- \overline{MR} master reset input (active LOW)
- O_0 to O_3 parallel outputs
- TC terminal count output

HEF40160BP(N): 16-lead DIL; plastic (SOT38-1)

HEF40160BD(F): 16-lead DIL; ceramic (cerdip) (SOT74)

HEF40160BT(D): 16-lead SO; plastic (SOT109-1)

(): Package Designator North America

SYNCHRONOUS MODE SELECTION

\overline{PE}	CEP	CET	MODE
L	X	X	preset
H	L	X	no change
H	X	L	no change
H	H	H	count

Notes

1. \overline{MR} = HIGH
2. H = HIGH state (the more positive voltage)
3. L = LOW state (the less positive voltage)
4. X = state is immaterial

TERMINAL COUNT GENERATION

CET	$(O_0 \cdot \overline{O_1} \cdot \overline{O_2} \cdot O_3)$	TC
L	L	L
L	H	L
H	L	L
H	H	H

Note

1. $TC = CET \cdot O_0 \cdot \overline{O_1} \cdot \overline{O_2} \cdot O_3$

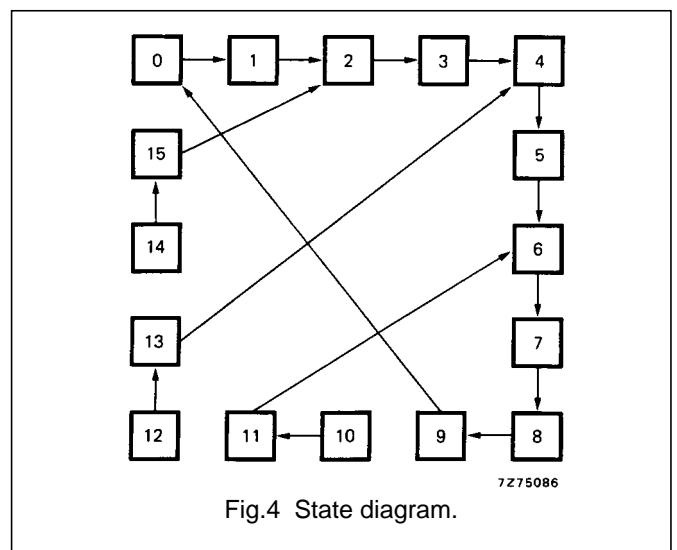

4-bit synchronous decade counter with asynchronous reset

HEF40160B MSI

AC CHARACTERISTICS

$V_{SS} = 0$ V; $T_{amb} = 25$ °C; input transition times ≤ 20 ns

	V_{DD} V	TYPICAL FORMULA FOR P (μ W)	
Dynamic power dissipation per package (P)	5 10 15	$1\,200 f_i + \sum (f_o C_L) \times V_{DD}^2$ $5\,600 f_i + \sum (f_o C_L) \times V_{DD}^2$ $16\,000 f_i + \sum (f_o C_L) \times V_{DD}^2$	where f_i = input freq. (MHz) f_o = output freq. (MHz) C_L = load capacitance (pF) $\sum (f_o C_L)$ = sum of outputs V_{DD} = supply voltage (V)

AC CHARACTERISTICS

$V_{SS} = 0$ V; $T_{amb} = 25$ °C; $C_L = 50$ pF; input transition times ≤ 20 ns

	V_{DD} V	SYMBOL	MIN.	TYP.	MAX.	TYPICAL EXTRAPOLATION FORMULA	
Propagation delays CP \rightarrow O _n HIGH to LOW	5	t_{PHL}		110	220	ns	83 ns + (0,55 ns/pF) C_L
	10		45	90	ns	34 ns + (0,23 ns/pF) C_L	
	15		30	60	ns	22 ns + (0,16 ns/pF) C_L	
LOW to HIGH	5	t_{PLH}		115	230	ns	88 ns + (0,55 ns/pF) C_L
	10		45	95	ns	34 ns + (0,23 ns/pF) C_L	
	15		35	65	ns	27 ns + (0,16 ns/pF) C_L	
CP \rightarrow TC HIGH to LOW	5	t_{PHL}		130	260	ns	103 ns + (0,55 ns/pF) C_L
	10		55	105	ns	44 ns + (0,23 ns/pF) C_L	
	15		35	75	ns	27 ns + (0,16 ns/pF) C_L	
LOW to HIGH	5	t_{PLH}		140	280	ns	113 ns + (0,55 ns/pF) C_L
	10		55	115	ns	44 ns + (0,23 ns/pF) C_L	
	15		40	80	ns	32 ns + (0,16 ns/pF) C_L	
CET \rightarrow TC HIGH to LOW	5	t_{PHL}		105	210	ns	78 ns + (0,55 ns/pF) C_L
	10		50	100	ns	39 ns + (0,23 ns/pF) C_L	
	15		35	75	ns	27 ns + (0,16 ns/pF) C_L	
LOW to HIGH	5	t_{PLH}		90	185	ns	63 ns + (0,55 ns/pF) C_L
	10		35	70	ns	24 ns + (0,23 ns/pF) C_L	
	15		25	50	ns	17 ns + (0,16 ns/pF) C_L	
$\overline{MR} \rightarrow$ O _n HIGH to LOW	5	t_{PHL}		120	245	ns	93 ns + (0,55 ns/pF) C_L
	10		50	100	ns	39 ns + (0,23 ns/pF) C_L	
	15		35	70	ns	27 ns + (0,16 ns/pF) C_L	
$\overline{MR} \rightarrow$ TC HIGH to LOW	5	t_{PHL}		145	295	ns	118 ns + (0,55 ns/pF) C_L
	10		60	120	ns	49 ns + (0,23 ns/pF) C_L	
	15		45	85	ns	37 ns + (0,16 ns/pF) C_L	

4-bit synchronous decade counter with asynchronous reset

HEF40160B
MSI

	V _{DD} V	SYMBOL	MIN.	TYP.	MAX.	TYPICAL EXTRAPOLATION FORMULA	
Output transition times HIGH to LOW	5	t _{THL}		60	120	ns	10 ns + (1,0 ns/pF) C _L
	10			30	60	ns	9 ns + (0,42 ns/pF) C _L
	15			20	40	ns	6 ns + (0,28 ns/pF) C _L
LOW to HIGH	5	t _{TLH}		60	120	ns	10 ns + (1,0 ns/pF) C _L
	10			30	60	ns	9 ns + (0,42 ns/pF) C _L
	15			20	40	ns	6 ns + (0,28 ns/pF) C _L

AC CHARACTERISTICS

V_{SS} = 0 V; T_{amb} = 25 °C; C_L = 50 pF; input transition times ≤ 20 ns

	V _{DD} V	SYMBOL	MIN.	TYP.	MAX.	
Minimum clock pulse width; LOW	5	t _{WCPL}	100	50	ns	see also waveforms Figs 5, 6, 7 and 8
	10		40	20	ns	
	15		30	15	ns	
Minimum $\overline{\text{MR}}$ pulse width; LOW	5	t _{WMRL}	100	50	ns	
	10		40	20	ns	
	15		30	15	ns	
Recovery time for $\overline{\text{MR}}$	5	t _{RMR}	25	0	ns	
	10		15	0	ns	
	15		10	0	ns	
Set-up times P _n → CP	5	t _{su}	110	55	ns	
	10		40	20	ns	
	15		30	15	ns	
$\overline{\text{PE}}$ → CP	5	t _{su}	120	60	ns	
	10		40	20	ns	
	15		25	10	ns	
CEP, CET → CP	5	t _{su}	260	130	ns	
	10		100	50	ns	
	15		70	35	ns	
Hold times P _n → CP	5	t _{hold}	20	-35	ns	
	10		10	-10	ns	
	15		5	-10	ns	
$\overline{\text{PE}}$ → CP	5	t _{hold}	15	-45	ns	
	10		5	-15	ns	
	15		5	-10	ns	
CEP, CET → CP	5	t _{hold}	25	-105	ns	
	10		15	-35	ns	
	15		10	-25	ns	

4-bit synchronous decade counter with asynchronous reset

HEF40160B
MSI

	V _{DD} V	SYMBOL	MIN.	TYP.	MAX.	
Maximum clock pulse frequency	5	f _{max}	2,5	5	MHz	
	10		7	14	MHz	
	15		9	18	MHz	

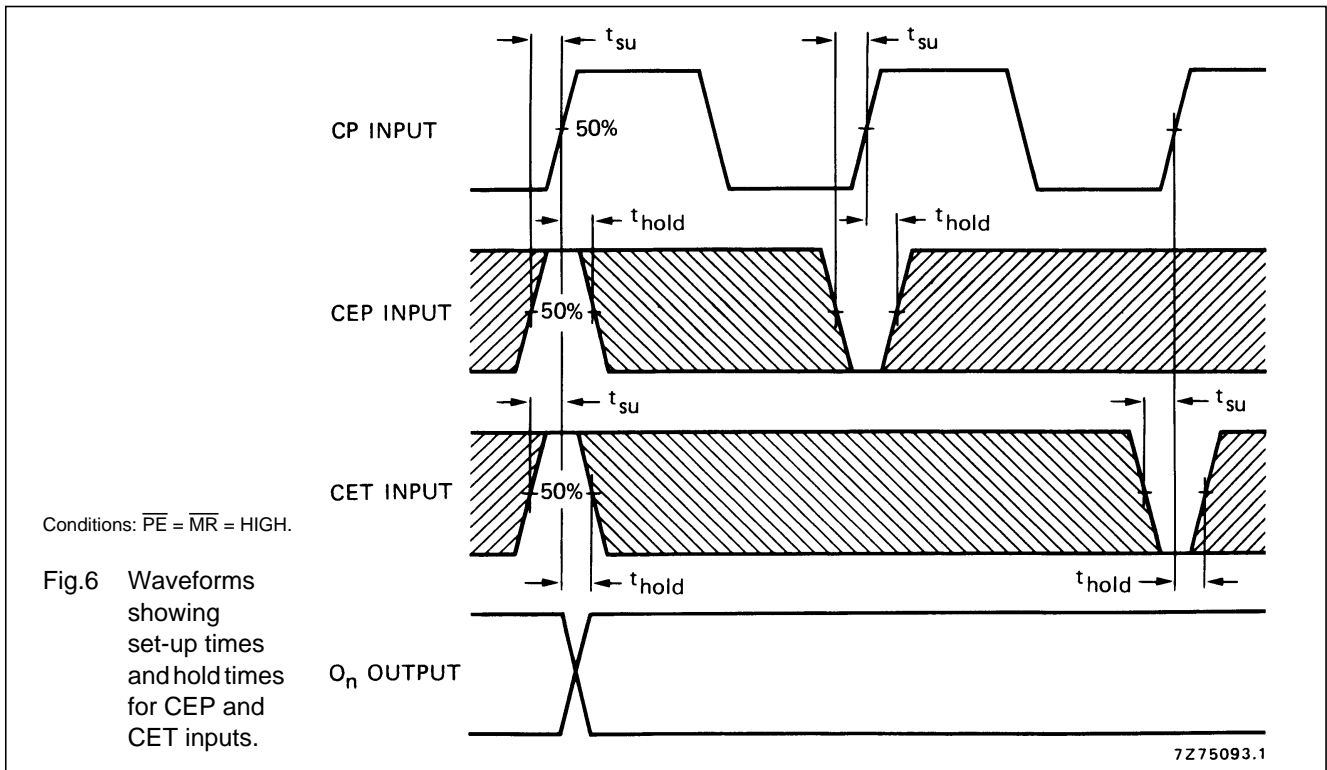
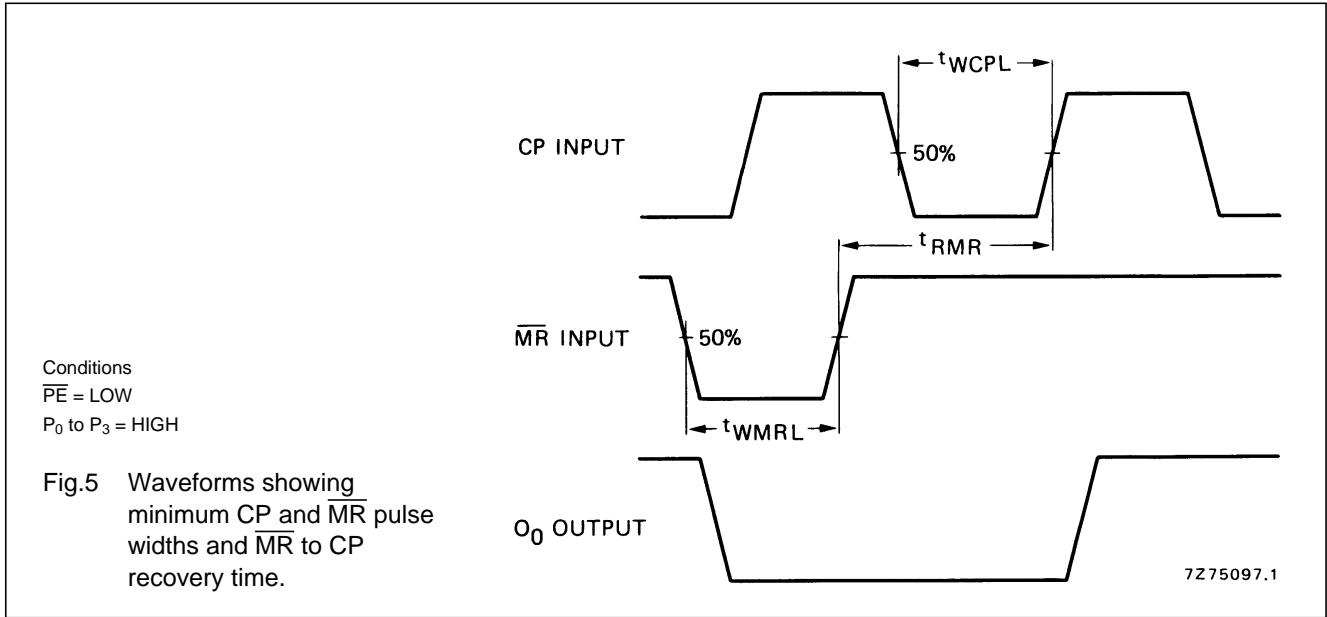

4-bit synchronous decade counter with asynchronous reset

HEF40160B
MSI

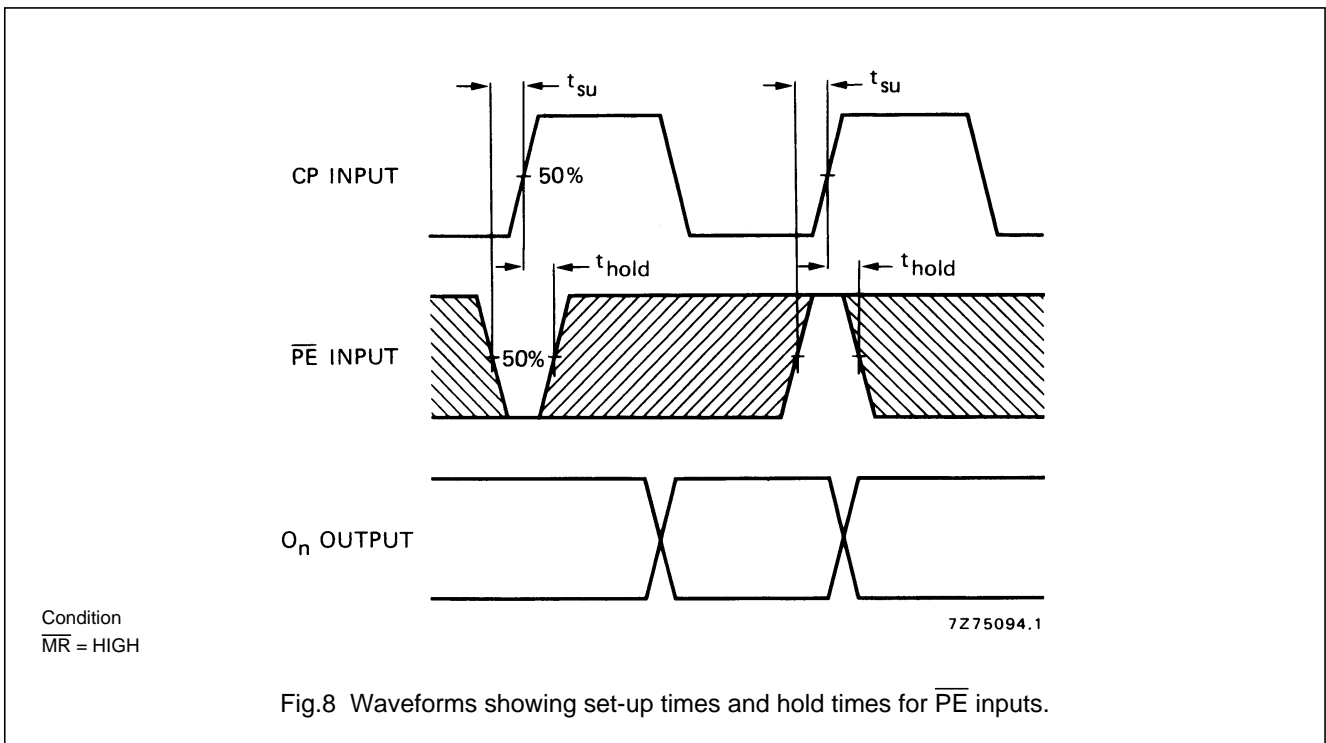
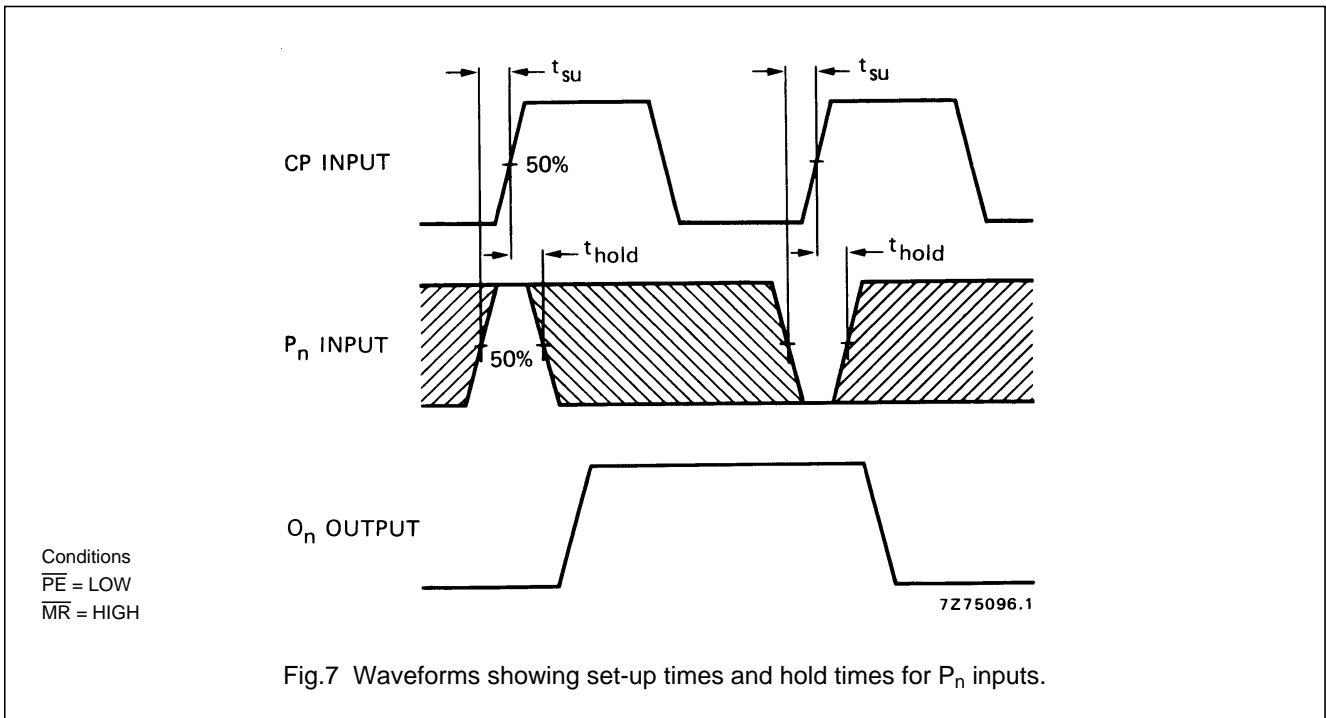

Note

Set-up and hold times are shown as positive values but may be specified as negative values.

4-bit synchronous decade counter with asynchronous reset

HEF40160B
MSI

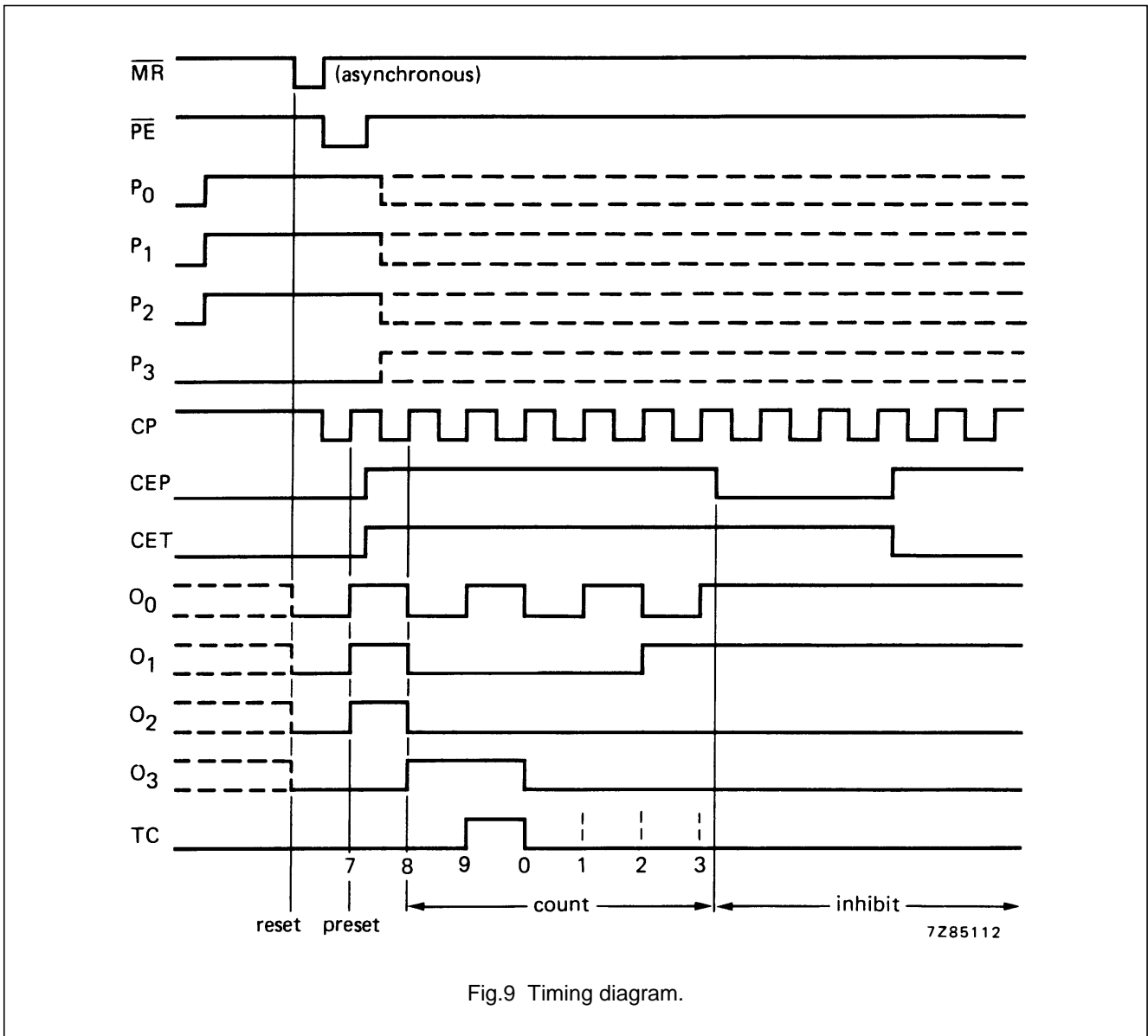

Fig.9 Timing diagram.

APPLICATION INFORMATION

An example of an application for the HEF40160B is:

- Programmable decade counter.

4-bit synchronous decade counter with asynchronous reset

HEF40160B
MSI

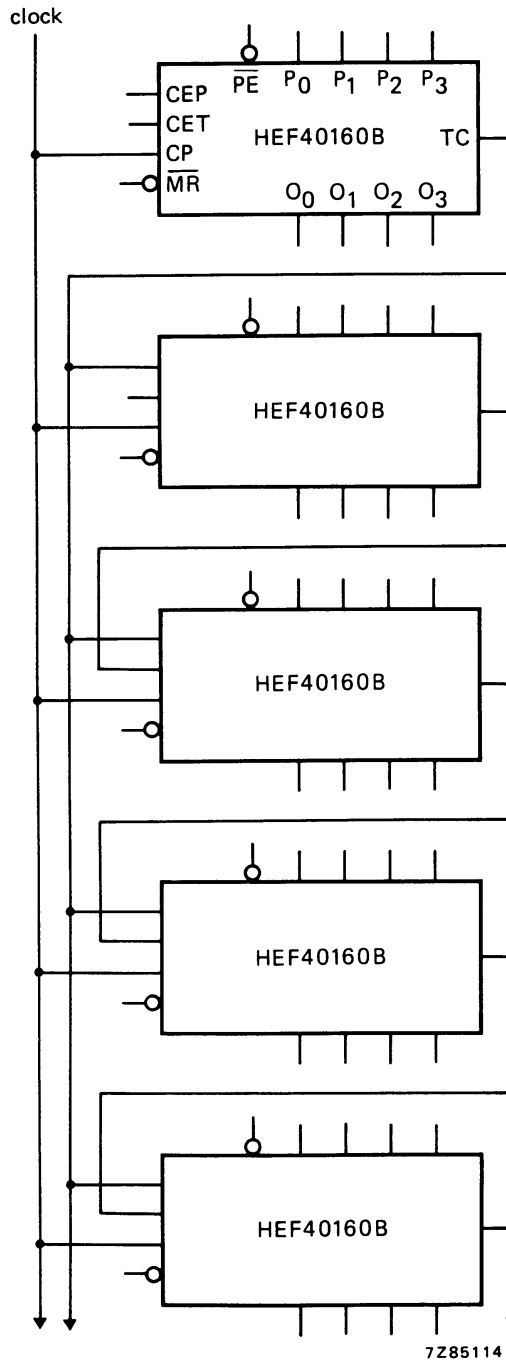

NOTE
On the TC outputs, glitches can occur during counting. In totally synchronous mode they will not have any adverse affect. However the TC output in asynchronous mode can cause problems.

7Z85114

Fig.10 Synchronous multi-stage counting scheme.