

<부록 4> 그래픽형 LCD 모듈 HG12605NY-LY

○ 제조 회사 : 현대 LCD

☞ 이 데이터 시트는 제조회사의 여러가지 자료를 바탕으로 저자가 다시 요약 정리한 것임.

(1) FEATURES

Model	Display Mode	Background Color	Viewing	Back Polarizer	Backlight
HG12605NG	STN, Positive	Gray	6:00	Relective	-
HG12605NY	STN, Positive	Yellow/Green	6:00	Relective	-
HG12605F-DY	STN, Positive	Black/White	6:00	Transflective	Yellow/Green LED
HG12605NG-EW	STN, Positive	Gray	6:00	Transflective	White EL
HG12605NG-LY	STN, Positive	Gray	6:00	Transmissive	Yellow/Green LED
HG12605NY-LY	STN, Positive	Yellow/Green	6:00	Transmissive	Yellow/Green LED
HG12605NGU	STN, Positive	Gray	12:00	Relective	-
HG12605NYU	STN, Positive	Yellow/Green	12:00	Relective	-
HG12605NGU-LY	STN, Positive	Gray	12:00	Transmissive	Yellow/Green LED
HG12605NYU-LY	STN, Positive	Yellow/Green	12:00	Transmissive	Yellow/Green LED

Standard Features :

- Display Format : 128×64 dots graphic LCD module
- Driving Method : 1/64 Duty, 1/6.4 Bias

(2) MECHANICAL SPECIFICATIONS

Item	Specification	Unit
Maximum Module Size	93.0(W)×70.0(H)×10.0(T) for EL or no backlight 93.0(W)×70.0(H)×12.5(T) for LED backlight	mm
Viewing Area	70.7(W)×38.8(H)	mm
Dot Pitch	0.52(W)×0.52(H)	mm
Dot Size	0.48(W)×0.48(H)	mm
Weight	100	g

(3) ABSOLUTE MAXIMUM RATINGS

Item	Symbol	Value			Unit	Condition
		Min.	Typ.	Max.		
Logic Supply Voltage	Vdd-Vss	-0.3	-	7.0	V	Ta=25℃
LCD Drive Supply Voltage	Vdd-Vo	-0.3	-	19.0	V	Ta=25℃
Input Voltage	Vi	-0.3	-	Vdd+0.3	V	Ta=25℃
Operating Temperature	Ta	0/-20	-	+50/+70	℃	Std/Ext
Storage Temperature	Tstg	-20/-30	-	+70/+85	℃	Std/Ext

☞ Std = standard version, Ext = extended temperature(high reliability) version

(4) ELECTRICAL CHARACTERISTICS(Ta=25℃)

Item	Symbol	Value			Unit	Condition
		Min.	Typ.	Max.		
Logic Supply Voltage	Vdd-Vss	4.75	5.00	5.25	V	
Logic Supply Current	Idd	-	9.5	14.3	mA	Vdd=5V
LCD Operating Voltage	Vdd-Vo	12.1	12.5	12.9	V	
LCD Drive Supply Current	Io	-	3.0	4.5	mA	Vdd=5V
Power Consumption	Pd	-	41.5	-	mW	Vdd=5V
Input Voltage "High" Level	V _{IH}	0.7Vdd	-	Vdd	V	
Input Voltage "Low" Level	V _{IL}	0	-	0.3Vdd	V	
Output Voltage "High" Level	V _{OH}	2.4	-	-	V	I _{OH} =-205μA
Output Voltage "Low" Level	V _{OL}	-	-	0.4	V	I _{OL} =1.6mA
Frame Frequency	Fr	-	60	-	Hz	Fosc=270kHz

(5) BACKLIGHTING CHARACTERISTICS(Ta=25℃) – LED UNIT

■ Absolute Maximum Ratings

Item	Symbol	Value			Unit	Condition
		Min.	Typ.	Max.		
Applied Voltage	V _{LED}	-	-	8	V	
Forward Current	I _f	-	-	308	mA	
Power Consumption	Pd	-	-	1322	mW	

■ Optoelectric Characteristics

Item	Symbol	Value			Unit	Condition
		Min.	Typ.	Max.		
Forward Voltage	V _f	3.9	4.1	4.3	V	
Power Consumption	Pd	-	574	-	mW	
Luminous		70	-	-	cd/m ²	I _f =140mA

(6) BACKLIGHTING CHARACTERISTICS(Ta=25℃) – EL UNIT

■ Absolute Maximum Ratings

Item	Symbol	Value			Unit	Condition
		Min.	Typ.	Max.		
Applied Voltage	V _{EL}	-	-	150	AC V _{rms}	
Applied Frequency	Fa	-	-	1000	Hz	

■ Optoelectric Characteristics

Item	Symbol	Value			Unit	Condition
		Min.	Typ.	Max.		
Applied Voltage	Va	80	100	120	AC V _{rms}	
Applied Frequency	Fa	-	400	-	Hz	
Current	Ia	-	4.57	4.7	mA	Va=100V
Power Consumption	Pd	-	457	-	mW	Fa=400Hz
Luminous		45	55	-	cd/m ²	Va=100V, Fa=400Hz

(7) PIN CONFIGURATION

Pin No.	Symbol	Level	Function
1	Vss	0V	Ground
2	Vdd	+5V	Logic Supply Voltage
3	Vo	-	LCD Driving Voltage, Operating Voltage
4	D/ \bar{I}	H/L	H = Data input, L = Instruction Code Input
5	R/ \bar{W}	H/L	H = Read(LCD → MPU), L = Write(MPU → LCD)
6	E	H, HL	Chip Enable Signal
7	DB0	H/L	Data Bit 0 (LSB)
8	DB1	H/L	Data Bit 1
9	DB2	H/L	Data Bit 2
10	DB3	H/L	Data Bit 3
11	DB4	H/L	Data Bit 4
12	DB5	H/L	Data Bit 5
13	DB6	H/L	Data Bit 6
14	DB7	H/L	Data Bit 7 (MSB)
15	CS1	H	Chip Select Signal for IC 1
16	CS2	H	Chip Select Signal for IC 2
17	\overline{RES}	H, HL	Reset Signal
18	Vout	-10V	Power Supply Voltage Output for LCD Driving
19	A(EL1)	-	LED(+) or EL Backlight Connection
20	K(EL2)	-	LED(-) or EL Backlight Connection

(8) BLOCK DIAGRAM

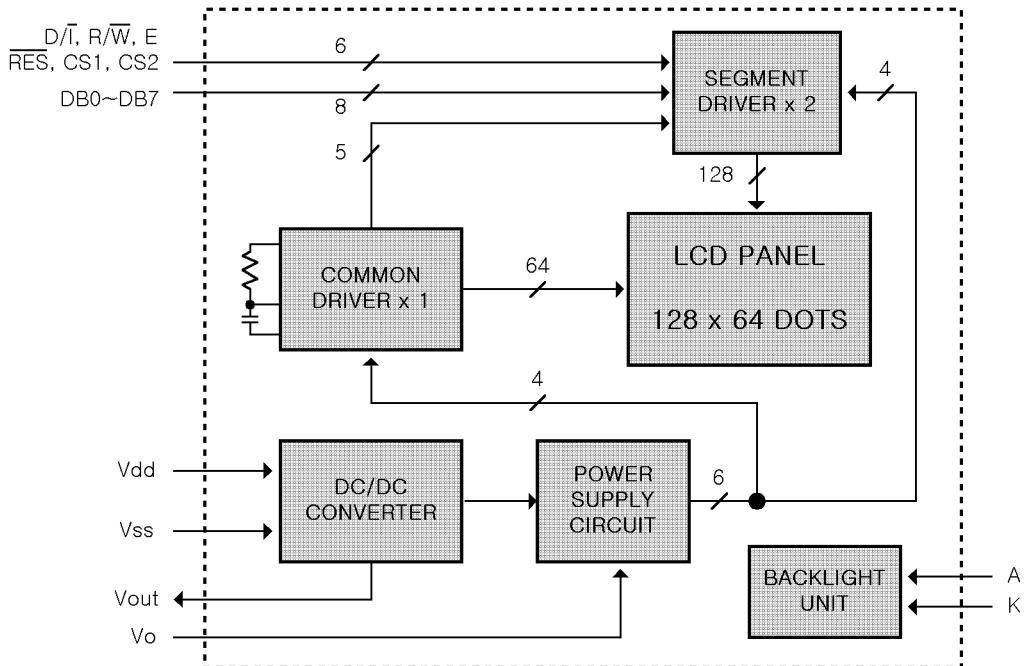

(9) POWER SUPPLY

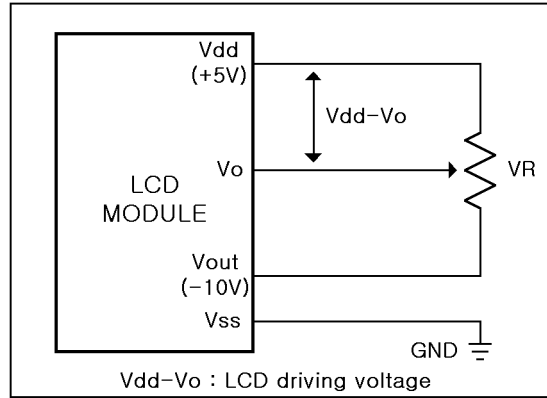

(10) ELECTRO-OPTICAL CHARACTERISTICS

Item	Symbol	Value			Unit	Condition	Note
		Min.	Typ.	Max.			
Viewing Angle	$\theta_2 - \theta_1$	60	-	-	deg	$C_r = 2.0$	1,2
	ϕ	-90	-	-			
Contrast Ratio	C_r	-	4	-	-	$\theta = 20^\circ, \phi = 0^\circ$	3
Response Time(rise)	T_r	-	150	220	ms	$\theta = 20^\circ, \phi = 0^\circ$	4
Response Time(fall)	T_f	-	150	220	ms	$\theta = 20^\circ, \phi = 0^\circ$	4

Note 1: Definition of angle θ & ϕ .

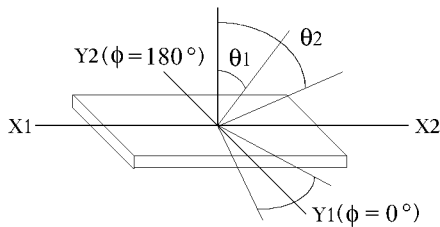

Note 2: Definition of viewing angle θ_1 & θ_2 .

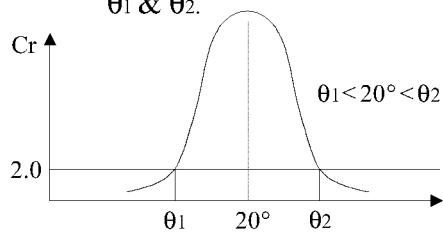

Note 3: Definition of contrast C_r

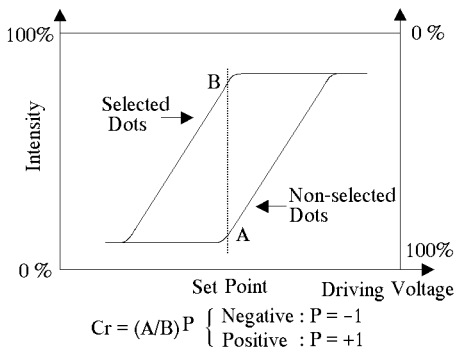

Note 4: Definition of optical response

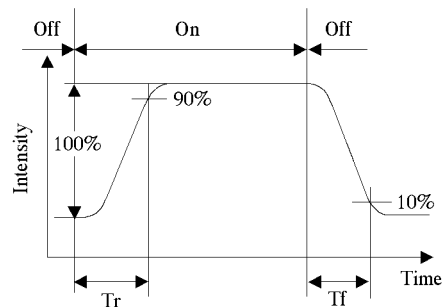

(11) MPU INTERFACE TIMING CHARACTERISTICS

■ MPU Interface Timing (Ta=25°C, Vdd=+5.0V±10%, Vss=0V)

Parameter	Symbol	Value			Unit	Note
		Min.	Typ.	Max.		
E cycle time	t _{cyc}	1000	-	-	ns	Figure 1,2
E high level width	P _{WEH}	450	-	-	ns	Figure 1,2
E low level width	P _{WEL}	450	-	-	ns	Figure 1,2
E rise time	t _r	-	-	25	ns	Figure 1,2
E fall time	t _f	-	-	25	ns	Figure 1,2
Address setup time	t _{AS}	140	-	-	ns	Figure 1,2
Address hold time	t _{AH}	10	-	-	ns	Figure 1,2
Data setup time	t _{DSW}	200	-	-	ns	Figure 1
Data delay time	t _{DDR}	-	-	320	ns	Figure 2
Data hold time(write)	t _{DHW}	10	-	-	ns	Figure 1
Data hold time(read)	t _{DHR}	20	-	-	ns	Figure 2

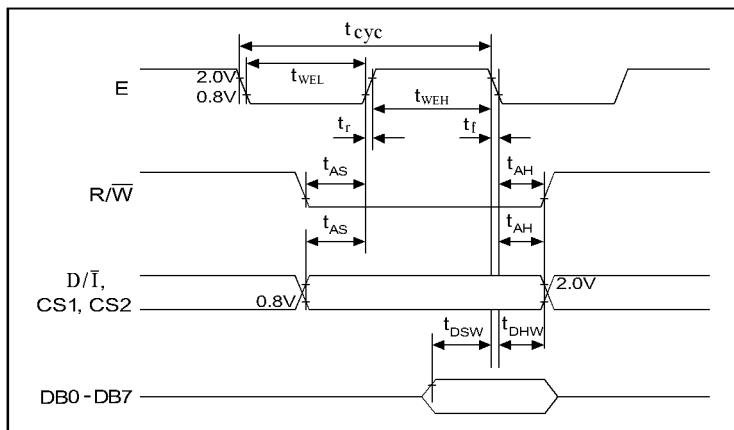

Figure 1. MPU Write Timing

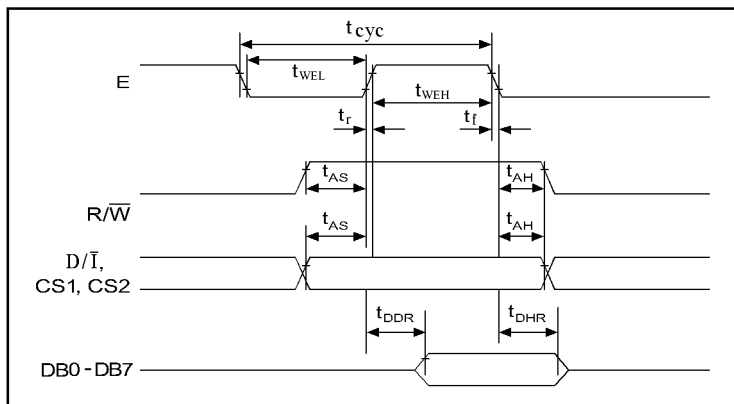

Figure 2. MPU Read Timing

(12) DISPLAY COMMANDS

Command	R/ \overline{W}	D/ \overline{I}	DB7	DB6	DB5	DB4	DB3	DB2	DB1	DB0	Condition	
Display ON/OFF	0	0	0	0	1	1	1	1	1	1/0	Controls the display on or off. Internal state and RAM data are not affected. (1 = on, 0 = off)	
Display start line	0	0	1	1	start line(0~63)						Specifies the RAM line displayed at the top of the screen.	
Set X address (page)	0	0	1	0	1	1	1	page(0~7)			Set the page(X address) of RAM at the page(X address) register.	
Set Y address	0	0	0	1	Y address(0~63)						Set the Y address of RAM in the Y address counter.	
Read status	1	0	busy	0	on/off	reset	0	0	0	0	Read the status. busy : 0 = ready, 1 = busy on/off : 0 = display on, 1 = off reset : 0 = normal, 1 = reset	
Write display data	0	1	Write data									Write data DB0~DB7 on the data bus into the display data RAM. After the access, Y address is automatically incremented by 1.
Read display data	1	1	Read data									Read data DB0~DB7 from the display data RAM to the data bus. After the access, Y address is automatically incremented by 1.

The above table lists the commands used with the graphic LCD segment driver. This LSI uses a combination of R/ \overline{W} and D/ \overline{I} to identify a data bus signal. Interpretation and execution of a command depends not on external clock but on internal timing alone. Therefore, a command can be executed so fast that no busy check is needed. A detailed description of commands follows.

■ DISPLAY ON/OFF

This command forces the display to turn on or off. The display data appears when D is 1 and disappears when D is 0. Through the data is not on the screen with D=0, it remains in the display data RAM. Therefore, you can make it appear by changing D=0 into D=1.

R/ \overline{W}	D/ \overline{I}	D7	DB6	DB5	DB4	DB3	DB2	DB1	DB0
0	0	0	0	1	1	1	1	1	D

D : 0 = display OFF, 1 = display ON

■ DISPLAY START LINE

This command specifies a line address marking the display line that corresponds to COM0 in the display data RAM. Display begins with the specified line address and covers as many lines as match the display duty in address ascending order. Dynamic line address change with the display start line common

682 부록 LCD 모듈의 기술자료

enables column-wise scrolling or page change.

R/ \bar{W}	D/ \bar{I}	DB7	DB6	DB5	DB4	DB3	DB2	DB1	DB0
0	0	1	1	A5	A4	A3	A2	A1	A0

A5 A4 A3 A2 A1 A0 : 000000 = line address 0
 000001 = line address 1
 000010 = line address 2
 ⋮
 111111 = line address 63

▣ SET PAGE(X ADDRESS)

This command is used to specify a page address equivalent to a row address for MPU access to the display data RAM. A required bit of the display data RAM can be accessed by specifying its page address and column address. Changing the page address causes no change in display.

R/ \bar{W}	D/ \bar{I}	DB7	DB6	DB5	DB4	DB3	DB2	DB1	DB0
0	0	1	0	1	1	1	A2	A1	A0

A2 A1 A0 : 000 = page 0 = row 0 to 7
 001 = page 1 = row 8 to 15
 010 = page 2 = row 16 to 23
 ⋮
 111 = page 7 = row 56 to 63

▣ SET Y ADDRESS

This command specifies a display data RAM column Y address. The column address is incremented by 1 each time the data is written or read to or from the MPU.

R/ \bar{W}	D/ \bar{I}	DB7	DB6	DB5	DB4	DB3	DB2	DB1	DB0
0	0	0	0	A5	A4	A3	A2	A1	A0

A5 A4 A3 A2 A1 A0 : 000000 = column address 0
 000001 = column address 1
 000010 = column address 2
 ⋮
 111111 = column address 63

■ READ STATUS

busy : The busy bit being "1" means that system is performing an internal operation or is reset. No command is accepted before busy="0". As long as the cycle time requirement is met no busy check is needed.

on/off : Indicates display on or off. 0 = display on, 1 = display off. This bit has polarity reverse to the DISPLAY ON/OFF command.

reset : Indicates that system is being initialized by the $\overline{\text{RES}}$ signal or the RESET command. 0 = display mode, 1 = being reset.

R/ $\overline{\text{W}}$	D/ $\overline{\text{I}}$	DB7	DB6	DB5	DB4	DB3	DB2	DB1	DB0
1	0	busy	0	on/off	reset	0	0	0	0

■ WRITE DISPLAY DATA

This command allows the MPU to write 8 bits of data into the display data RAM. Once the data is written, the column Y address is automatically incremented by 1.

R/ $\overline{\text{W}}$	D/ $\overline{\text{I}}$	DB7	DB6	DB5	DB4	DB3	DB2	DB1	DB0
0	1	D7	D6	D5	D4	D3	D2	D1	D0

■ READ DISPLAY DATA

This command allows the MPU to read 8 bits of data from the display data RAM location specified by a column address and a page address. Once the data is read, the column Y address is automatically incremented by 1. A dummy read is needed immediately after the column address is set.

R/ $\overline{\text{W}}$	D/ $\overline{\text{I}}$	DB7	DB6	DB5	DB4	DB3	DB2	DB1	DB0
1	1	D7	D6	D5	D4	D3	D2	D1	D0

(13) EXTERNAL DIMENSION

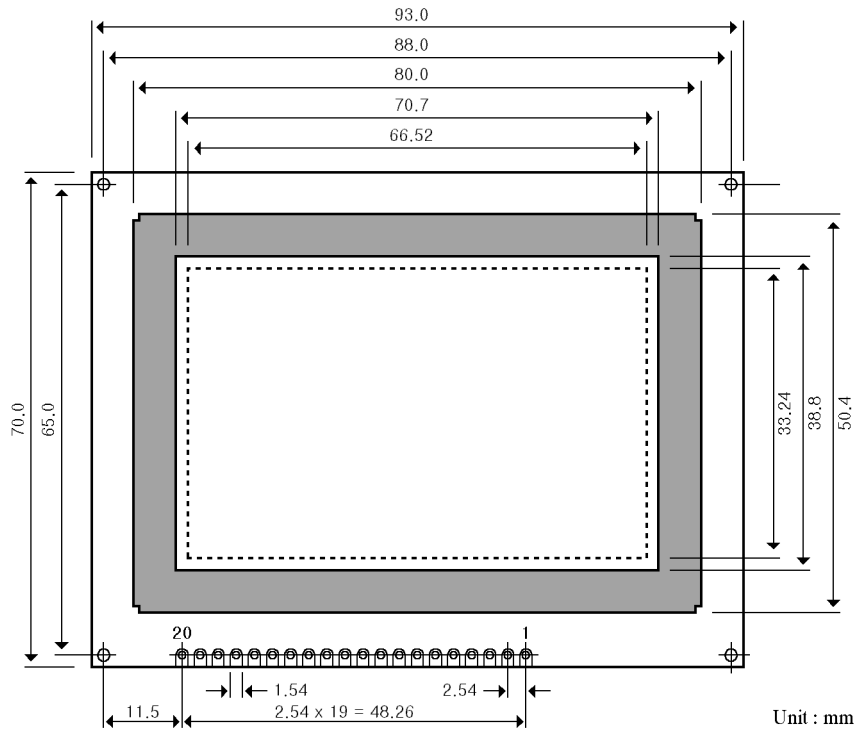

★휴게식★ 현대 LCD의 LCD 모듈 모델명을 정하는 규칙

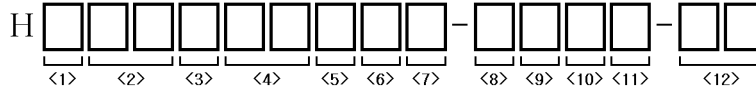

No.	Item	Symbol	Description
<1>	LCD Type	C G B P T	Character Type Module - PCB Graphic Type Module - PCB COB(Chip on Board) Type Module COG(Chip on Glass) Type Module TAB(Tape Automated Bonding) Type Module
<2>	① Character Type ② Graphic Type		Number of Character per Line Number of Column Dots(Upper 2 Digits Only)
<3>	① Character Type ② Graphic Type		Number of Line LSI Controller(5=With Controller, 6=Without Controller)
<4>	Development Number	01 ~ 99	
<5>	Display Mode	Nil P N Q F R	TN Extended Temperature TN STN Extended Temperature STN FSTN Extended Temperature FSTN
<6>	LCD Color	Nil Y B G	White(TN, FSTN) Yellow/Green(STN) Blue(STN), Black(TN, FSTN) Gray(STN)
<7>	Viewing Direction	Nil U L R	6:00 O'Clock 12:00 O'Clock 9:00 O'Clock 3:00 O'Clock
<8>	Backlight	Nil T X E M L D G H	Without Backlight + Reflective Without Backlight + Transflective Without Backlight + Transmissive EL + Transflective EL + Transmissive LED + Transmissive LED + Transflective CCFL + Transmissive CCFL + Transflective
<9>	Backlight Color	Nil A B R W Y	Without Backlight Amber(LED) Blue/Green(EL) Red(LED) White(EL, CCFL) Yellow/Green(LED)
<10>	Holder	Nil Z J K S P	Black Coating Zinc Natural Zinc White Nickel Coating Stainless Plastic
<11>	Connector	Nil C F O	Without Connector Pin Header Cable Other Connector
<12>	Revision Number	01 ~ 99	