

Document Title

2M x 16 bit Low Low Power 1T/1C Pseudo SRAM

Revision history

Revision No.	History	Draft Date	Remark
1.0	Initial	Jan. 04. '01	Preliminary
1.1	Revised - Change Pin Connection - Improve tOE from 45ns to 30ns - Correct State Diagram	Jul. 03. '01	Preliminary
1.2	Revised - Correct Package Dimension - Change Absolute Maximum Ratings	Jul. 18. '01	Preliminary
1.3	Revised - DC Electrical Characteristics (ISB1, IDPD, ICC1) - State Diagram - Power Up Sequence - Deep Power Down Sequence - Read/Write Cycle Note - Release standby current from 100 μ A to 120 μ A	Oct. 06. '01	Preliminary
1.4	Revised - DC Electrical Characteristics (ICC1: 3mA -> 5mA)	Nov. 07. '01	Preliminary
1.5	Revised - Add 70ns Part - Power Up Sequence	Dec. 20. '01	Preliminary
1.6	Revised - Improve ICC2@70ns 30mA to 25mA - Improve ICC2@85ns 30mA to 20mA - Improve Ambient Temperature C/E to E/I (0 $^{\circ}$ C~85 $^{\circ}$ C/-25 $^{\circ}$ C~85 $^{\circ}$ C \rightarrow -25 $^{\circ}$ C~85 $^{\circ}$ C/-40 $^{\circ}$ C~85 $^{\circ}$ C) - Improve Maximum Absolute Ratings (Vdd : -0.3V to 3.3V \rightarrow -0.3V to 3.6V) - Improve tOE@85ns 30ns to 20ns	Feb. 27. '02	Preliminary
1.7	Revised - Pin Description - Power Up & Deep Power Down Exit Sequence	Mar. 11. '02	Final

This document is a general product description and is subject to change without notice. Hynix Semiconductor Inc. does not assume any responsibility for use of circuits described. No patent licenses are implied.

2M x 16 bit Low Low Power 1T/1C SRAM

DESCRIPTION

The HY64UD16322M is a 32Mbit 1T/1C SRAM featured by high-speed operation and super low power consumption. The HY64UD16322M adopts one transistor memory cell and is organized as 2,097,152 words by 16bits. The HY64UD16322M operates in the extended range of temperature and supports a wide operating voltage range. The HY64UD16322M also supports the deep power down mode for a super low standby current. The HY64UD16322M delivers the high-density low power SRAM capability to the high-speed low power system.

FEATURES

- CMOS Process Technology
- 2M x 16 bit Organization
- TTL compatible and Tri-state outputs
- Deep Power Down : Memory cell data hold invalid
- Standard pin configuration : 48-FBGA
- Data mask function by /LB, /UB

PRODUCT FAMILY

Product No.	Voltage [V]	Mode	Power Dissipation			Speed tRC[ns]	Temp. [°C]
			(ISB1,Max)	(IDPD,Max)	(Icc2,Max)		
HY64UD16322M-DF70E	2.7~3.3	1CS with /UB,/LB:tCS ¹	140μA	2μA	25mA	70	-25~85
HY64UD16322M-DF70I	2.7~3.3	1CS with /UB,/LB:tCS ¹	140μA	2μA	25mA	70	-40~85
HY64UD16322M-DF85E	2.7~3.3	1CS with /UB,/LB:tCS ¹	120μA	2μA	20mA	85	-25~85
HY64UD16322M-DF85I	2.7~3.3	1CS with /UB,/LB:tCS ¹	120μA	2μA	20mA	85	-40~85

Note 1. tCS - /UB,/LB=High : Chip Deselect.

PIN CONNECTION (Top View)

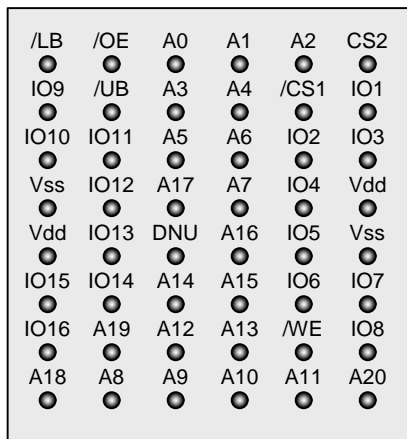

BLOCK DIAGRAM

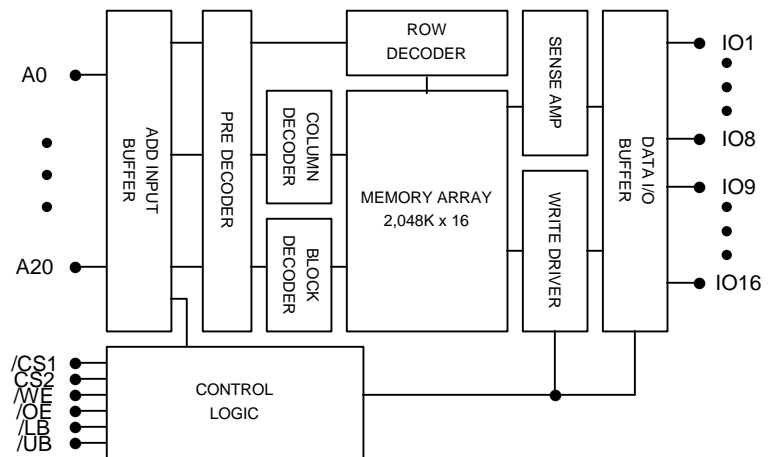

PIN DESCRIPTION

Pin Name	Pin Function	Pin Name	Pin Function
/CS1	Chip Select	/OE	Output Enable
CS2	Deep Power Down	IO1~IO8	Lower Data Inputs/Outputs
/WE	Write Enable	IO9~IO16	Upper Data Inputs/Outputs
/LB	Lower Byte(IO1~IO8)	A0~A20	Address Inputs
/UB	Upper Byte(IO9~IO16)	Vdd	Power(2.7V~3.3V)
DNU	Do Not Use	Vss	Ground

This document is a general product description and is subject to change without notice. Hynix Semiconductor Inc. does not assume any responsibility for use of circuits described. No patent licenses are implied.

ORDERING INFORMATION

Part Number	Speed	Power	Temperature	Package
HY64UD16322M-E	70 / 85	LL-Part	E ¹	FBGA
HY64UD16322M-I	70 / 85	LL-Part	I ²	FBGA

Note

1. E : Extended Temp. (-25°C ~ 85°C)
2. I : Industrial Temp. (-40°C ~ 85°C)

ABSOLUTE MAXIMUM RATINGS ¹

Symbol	Parameter	Rating	Unit	Remark
V _{IN} , V _{OUT}	Input/Output Voltage	-0.3 to V _{DD} +0.3	V	
V _{DD}	Power Supply	-0.3 to 3.6	V	
T _A	Ambient Temperature	-25 to 85	°C	HY64UD16322M-E
		-40 to 85	°C	HY64UD16322M-I
T _{STG}	Storage Temperature	-55 to 150	°C	
P _D	Power Dissipation	1.0	W	
T _{SOLDER}	Ball Soldering Temperature & Time	260•10	°C•sec	

Note

1. Stresses greater than those listed under ABSOLUTE MAXIMUM RATINGS may cause permanent damage to the device. This is stress rating only and the functional operation of the device under these or any other conditions above those indicated in the operation of this specification is not implied. Exposure to the absolute maximum rating conditions for extended period may affect reliability.

TRUTH TABLE

/CS1	CS2	/WE	/OE	/LB	/UB	Mode	I/O Pin		Power
							I/O1~I/O8	I/O9~I/O16	
H	H	X	X	X	X	Deselected	High-Z	High-Z	Standby
X	L	X	X	X	X	Deselected	High-Z	High-Z	Deep Power Down
X	H	X	X	H	H	Deselected	High-Z	High-Z	Standby
L	H	L	X	L	H	Write	D _{IN}	High-Z	Active
L	H	H	L	L	H	Read	D _{OUT}	High-Z	Active
L	H	H	H	L	H	Output Disabled	High-Z	High-Z	Active
L	H	L	X	H	L	Write	High-Z	D _{IN}	Active
L	H	H	L	H	L	Read	High-Z	D _{OUT}	Active
L	H	H	H	H	L	Output Disabled	High-Z	High-Z	Active
L	H	L	X	L	L	Write	D _{IN}	D _{IN}	Active
L	H	H	L	L	L	Read	D _{OUT}	D _{OUT}	Active
L	H	H	H	L	L	Output Disabled	High-Z	High-Z	Active

Note

1. H=V_{IH}, L=V_{IL}, X=don't care(V_{IL} or V_{IH})
2. /UB, /LB(Upper, Lower Byte enable)
 These active LOW inputs allow individual bytes to be written or read.
 When /LB is LOW, data is written or read to the lower byte, I/O1 - I/O8.
 When /UB is LOW, data is written or read to the upper byte, I/O9 - I/O16.

RECOMMENDED DC OPERATING CONDITION

Symbol	Parameter	Min.	Typ.	Max.	Unit
V _{dd}	Supply Voltage	2.7	3.0	3.3	V
V _{ss}	Ground	0	-	0	V
V _{IH}	Input High Voltage	2.2	-	V _{dd} +0.3	V
V _{IL}	Input Low Voltage	-0.3 ¹	-	0.6	V

Note 1. V_{IL}=-1.5V for pulse width less than 10ns
Undershoot is sampled, not 100% tested.

DC ELECTRICAL CHARACTERISTICS

V_{dd}=2.7V~3.3V, T_A= -25°C to 85°C(E) / -40°C to 85°C(I)

Sym.	Parameter	Test Condition	Min.	Typ.	Max.	Unit	
I _{LI}	Input Leakage Current	V _{ss} ≤V _{IN} ≤V _{dd}	-1	-	1	μA	
I _{LO}	Output Leakage Current	V _{ss} ≤V _{OUT} ≤V _{dd} , /CS1=V _{IH} , CS2=V _{IH} , /OE=V _{IH} or /WE=V _{IL}	-1	-	1	μA	
I _{CC}	Operating Power Supply Current	/CS1=V _{IL} , CS2=V _{IH} , V _{IN} =V _{IH} or V _{IL} , I _{I/O} =0mA	-	-	3	mA	
I _{CC1}	Average Operating Current	/CS1≤0.2V, CS2≥V _{dd} -0.2V, V _{IN} ≤0.2V or V _{IN} ≥V _{dd} -0.2V, Cycle Time=1μs. 100% Duty, I _{I/O} =0mA	-	-	5	mA	
I _{CC2}		/CS1=V _{IL} , CS2=V _{IH} , V _{IN} =V _{IH} or V _{IL} , Cycle Time=Min. 100% Duty, I _{I/O} =0mA	70ns	-	-	25	mA
			85ns	-	-	20	mA
I _{SB}	TTL Standby Current	/CS1,CS2=V _{IH} or /UB,/LB= V _{IH}	-	-	0.5	mA	
I _{SB1}	Standby Current(CMOS Input)	/CS1, CS2≥V _{dd} -0.2V or /UB,/LB ≥V _{dd} -0.2V	70ns	-	-	140	μA
			85ns	-	-	120	μA
I _{DPD}	Deep Power Down Current	CS2≤V _{ss} +0.2V	-	-	2	μA	
V _{OL}	Output Low Voltage	I _{OL} =2.1mA	-	-	0.4	V	
V _{OH}	Output High Voltage	I _{OH} =-1.0mA	2.4	-	-	V	

CAPACITANCE

(Temp = 25°C, f=1.0MHz)

Symbol	Parameter	Condition	Max.	Unit
C _{IN}	Input Capacitance(Add, /CS1, CS2, /WE, /OE, /UB, /LB)	V _{IN} =0V	8	pF
C _{OUT}	Output Capacitance(I/O)	V _{I/O} =0V	10	pF

Note : These parameters are sampled and not 100% tested

AC CHARACTERISTICS

V_{dd}=2.7V~3.3V, T_A = -25°C to 85°C(E) / -40°C to 85°C(I), unless otherwise specified

#	Symbol	Parameter	-70		-85		Unit
			Min.	Max.	Min.	Max.	
Read Cycle							
1	t _{RC}	Read Cycle Time	70	-	85	-	ns
2	t _{AA}	Address Access Time	-	70	-	85	ns
3	t _{ACS}	Chip Select Access Time	-	70	-	85	ns
4	t _{OE}	Output Enable to Output Valid	-	20	-	20	ns
5	t _{BA}	/LB, /UB Access Time	-	70	-	85	ns
6	t _{CLZ}	Chip Select to Output in Low Z	10	-	10	-	ns
7	t _{OLZ}	Output Enable to Output in Low Z	5	-	5	-	ns
8	t _{BLZ}	/LB, /UB Enable to Output in Low Z	10	-	10	-	ns
9	t _{CHZ}	Chip Disable to Output in High Z	0	20	0	30	ns
10	t _{OHZ}	Out Disable to Output in High Z	0	20	0	30	ns
11	t _{BHZ}	/LB, /UB Disable to Output in High Z	0	20	0	30	ns
12	t _{OH}	Output Hold from Address Change	10	-	10	-	ns
Write Cycle							
13	t _{WC}	Write Cycle Time	70	-	85	-	ns
14	t _{CW}	Chip Selection to End of Write	60	-	70	-	ns
15	t _{AW}	Address Valid to End of Write	60	-	70	-	ns
16	t _{BW}	/LB, /UB Valid to End of Write	60	-	70	-	ns
17	t _{AS}	Address Set-up Time	0	-	0	-	ns
18	t _{WP}	Write Pulse Width	50	-	60	-	ns
19	t _{WR}	Write Recovery Time	0	-	0	-	ns
20	t _{WHZ}	Write to Output in High Z	0	20	0	30	ns
21	t _{DW}	Data to Write Time Overlap	30	-	30	-	ns
22	t _{DH}	Data Hold from Write Time	0	-	0	-	ns
23	t _{OW}	Output Active from End of Write	5	-	5	-	ns

AC TEST CONDITIONS

T_A = -25°C to 85°C(E) / -40°C to 85°C(I), unless otherwise specified

Parameter	Value
Input Pulse Level	0.4V to 2.2V
Input Rising and Fall Time	5ns
Input and Output Timing Reference Level	1.5V
Output Load	See Below

AC TEST LOADS

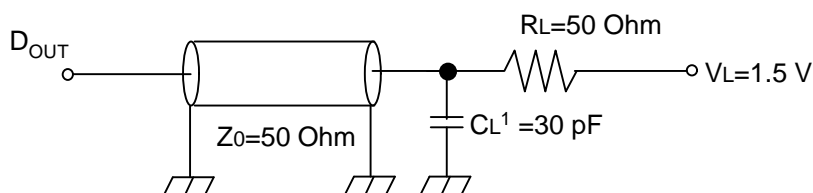

Note

1. Including jig and scope capacitance.

Power-Up Sequence

1. Supply power.
2. Maintain stable power for longer than 200 μ s.

Deep Power Down Entry Sequence

1. Keep CS2 low state.
Deep power down mode is maintained while CS2 is low state.

Deep Power Down Exit Sequence

1. Keep CS2 high state.
2. Maintain stable power for longer than 200 μ s.

STATE DIAGRAM

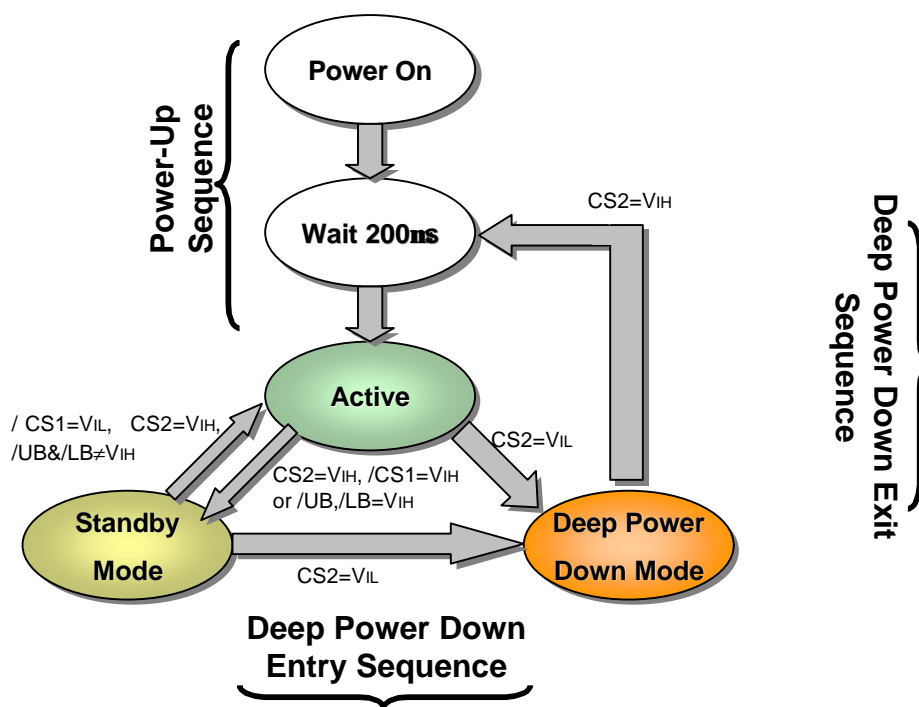

STANDBY MODE CHARACTERISTICS

Mode	Memory Cell Data	Standby Current[μ A]	Wait Time[μ s]
Standby	Valid	140 / 70ns	0
		120 / 85ns	
Deep Power Down	Invalid	2	200

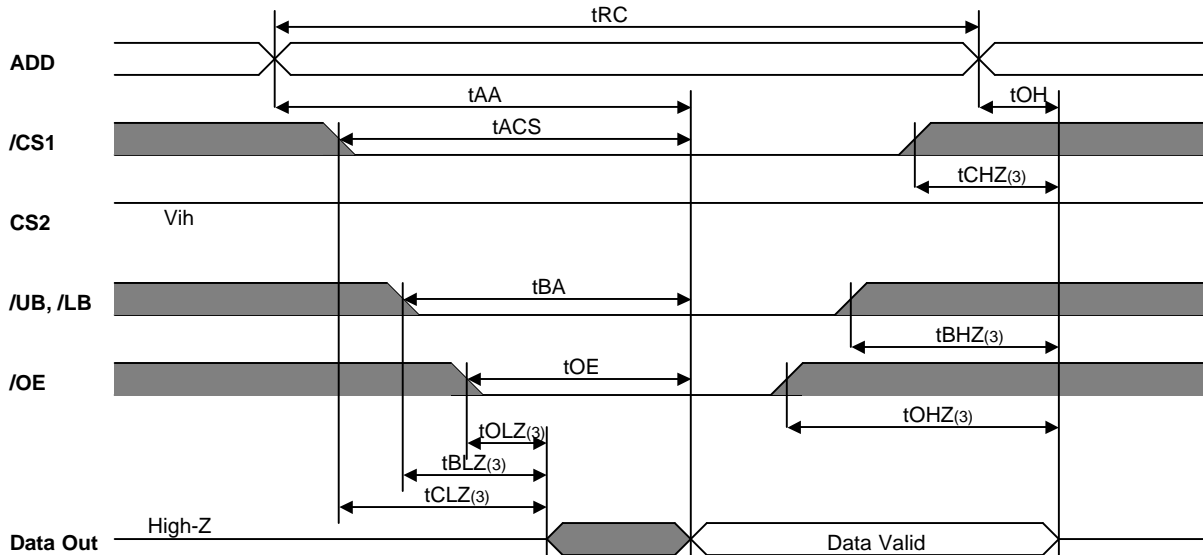
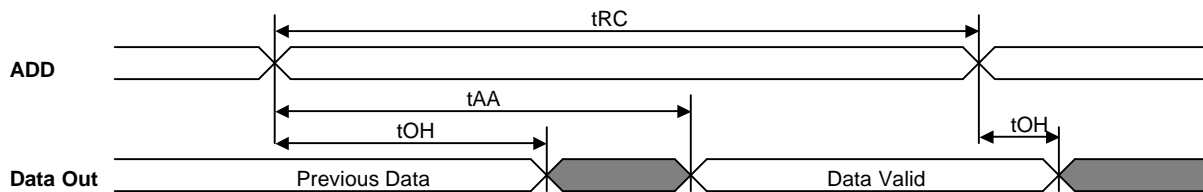
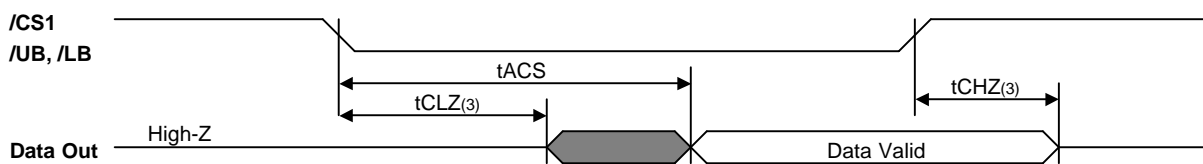
TIMING DIAGRAM
READ CYCLE 1 (Note 1, 4)

READ CYCLE 2 (Note 1, 2, 4) (CS2=Vih)

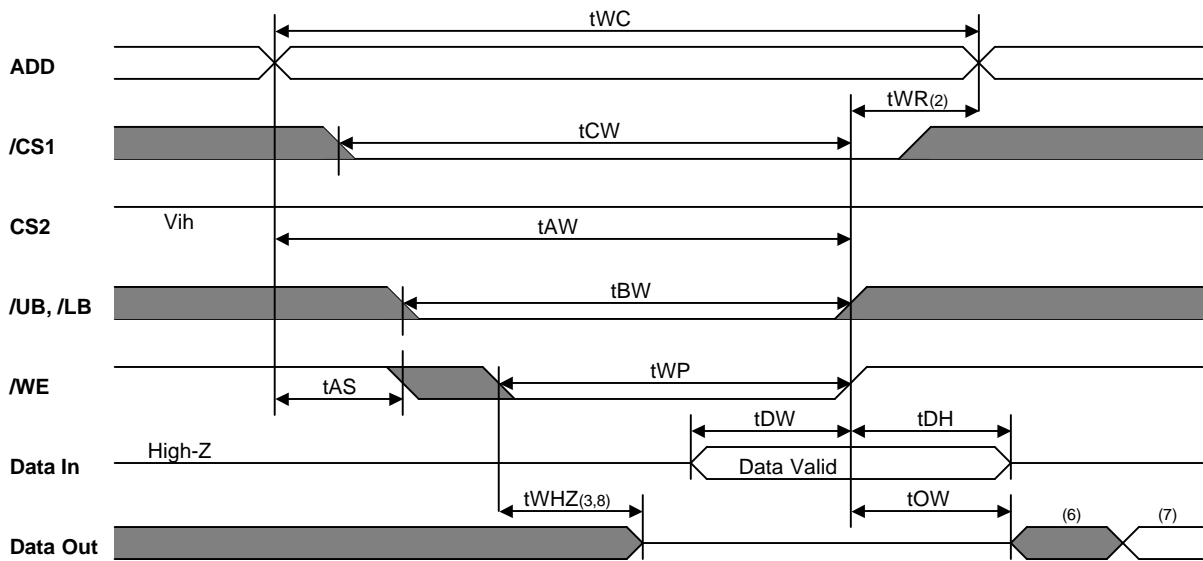
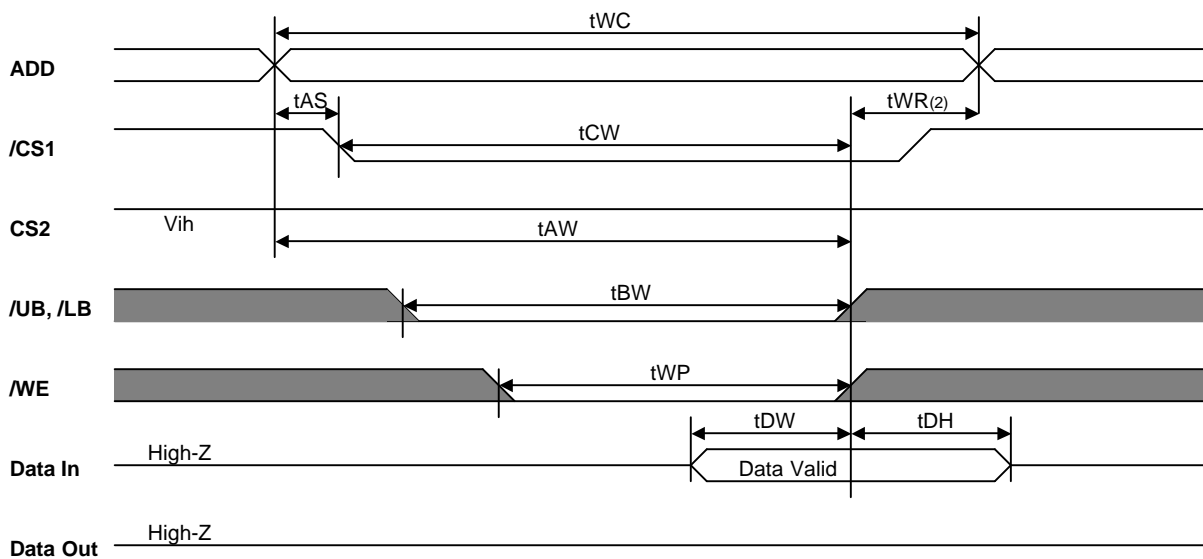
READ CYCLE 3 (Note 1, 2, 4) (CS2=Vih)

Notes :

1. Read Cycle occurs whenever a high on the /WE and /OE is low, while /UB and/or /LB and /CS1 and CS2 are in active status.
2. /OE = V_{IL}
3. tCHZ, tBHZ and tOHZ are defined as the time at which the outputs achieve the high impedance state and tOLZ, tBLZ and tCLZ are defined as the time at which the outputs achieve the low impedance state. These are not referenced to output voltage levels.
4. /CS1 in high for the standby, low for active.
/UB and /LB in high for the standby, low for active.

WRITE CYCLE 1 (Note 1, 4, 5, 9, 10) (/WE Controlled)

WRITE CYCLE 2 (Note 1, 4, 5, 9, 10) (/CS1 Controlled)

Notes :

1. A write occurs during the overlap of low /CS1, low /WE and low /UB and/or /LB.
2. t_{WR} is measured from the earlier of /CS1, /LB, /UB, or /WE going high to the end of write cycle.
3. During this period, I/O pins are in the output state so that the input signals of opposite phase to the output must not be applied.
4. If the /CS1, /LB and /UB low transition occur simultaneously with the /WE low transition or after the /WE transition, outputs remain in a high impedance state.
5. /OE is continuously low (/OE= V_{IL})
6. Q(data out) is the invalid data.
7. Q(data out) is the read data of the next address.
8. t_{WHZ} is defined as the time at which the outputs achieve the high impedance state. It is not referenced to output voltage levels.
9. /CS1 in high for the standby, low for active. /UB and /LB in high for the standby, low for active.
10. Do not input data to the I/O pins while they are in the output state.

AVOID TIMING

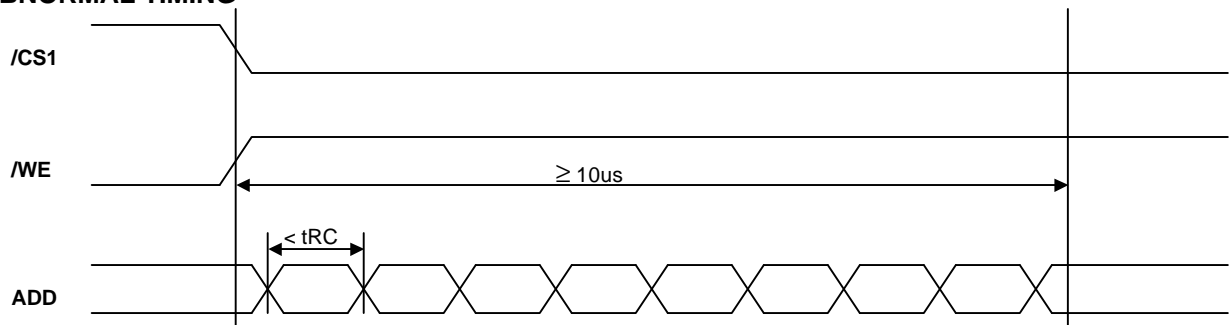
Hynix 1T/1C SRAM has a timing which is not supported at read operation. If your system has multiple invalid address signal shorter than t_{RC} during over 10us at read operation which showed in abnormal timing, Hynix 1T/1C SRAM needs a normal read timing at least during 10us which showed in avoidable timing(1) or toggle the $/CS1$ to high ($\geq t_{RC}$) one time at least which showed in avoidable timing(2)

ABNORMAL TIMING



AVOIDABLE TIMING(1)

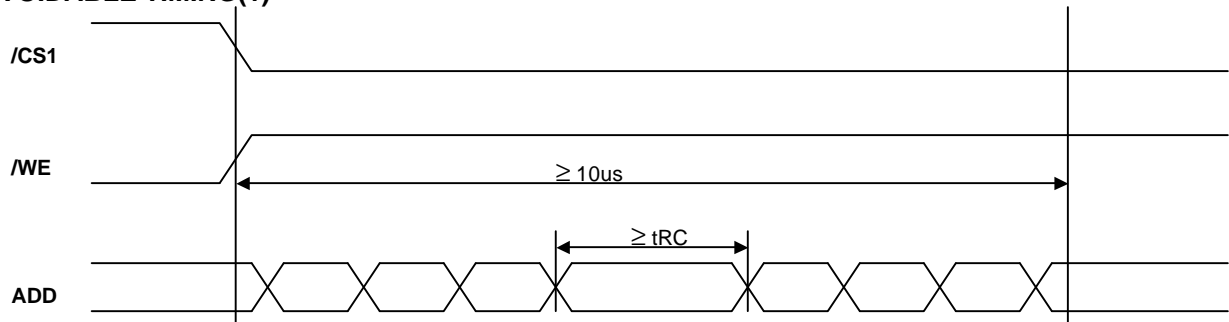

AVOIDABLE TIMING(2)

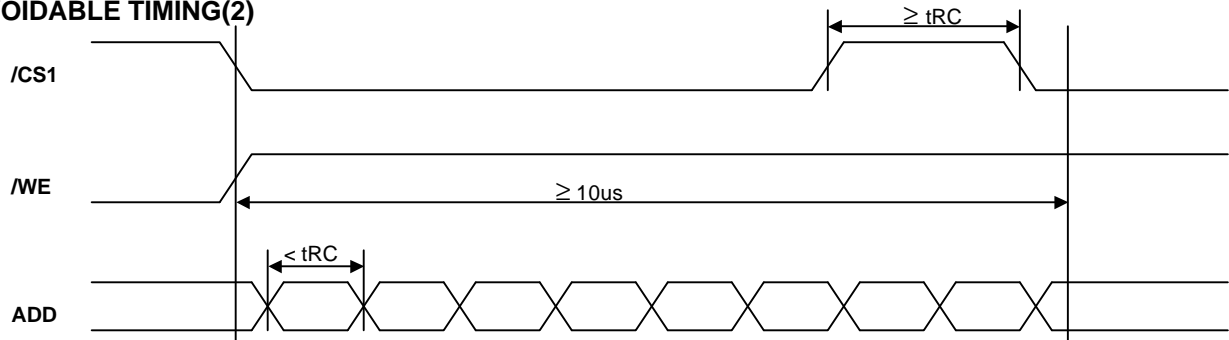

PACKAGE DIMENSION

48ball Fine Pitch Ball Grid Array Package(F)

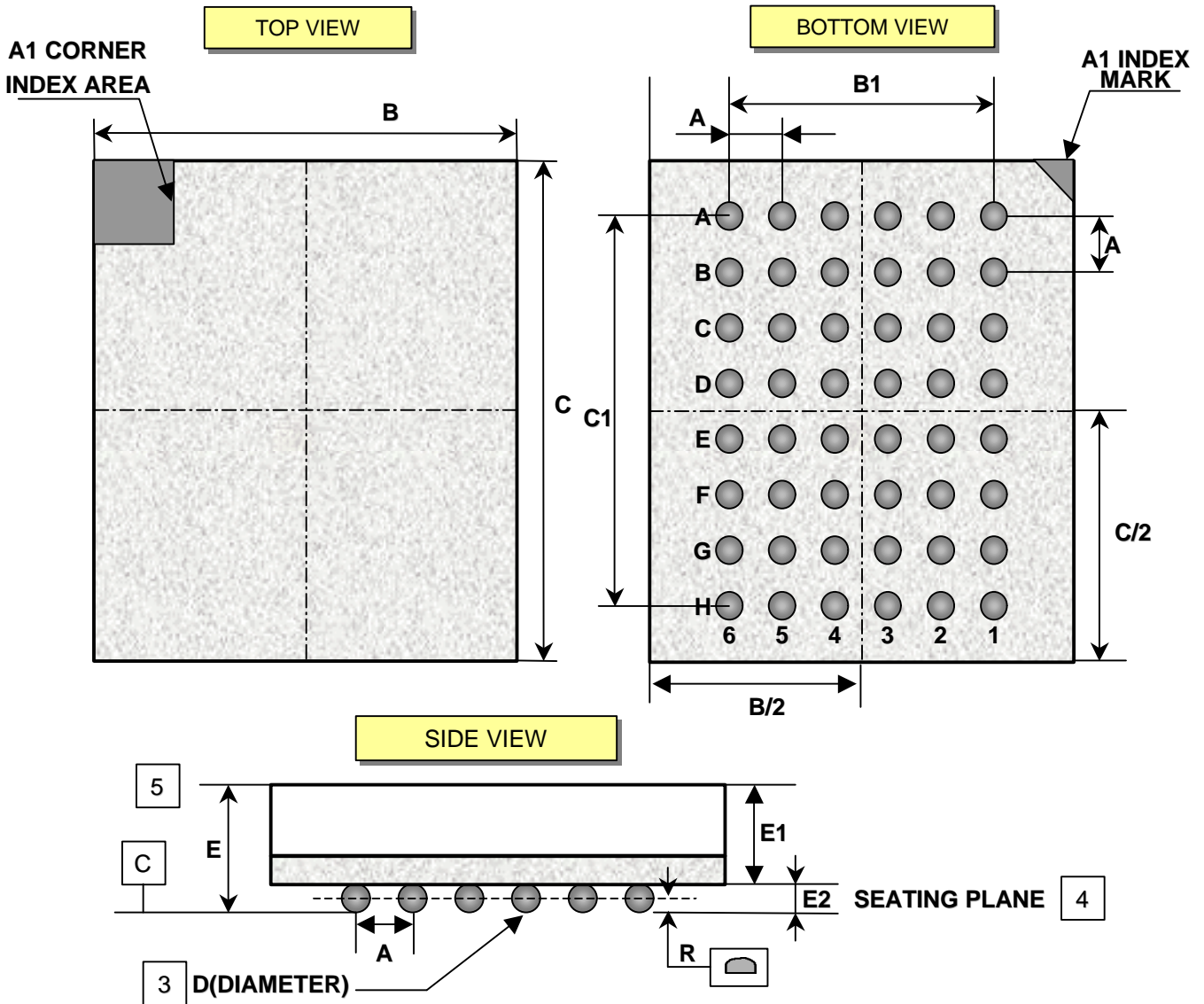

unit : mm

Symbol	Min.	Typ.	Max.
A	-	0.75	-
B	6.90	7.00	7.10
B1	-	3.75	-
C	7.90	8.00	8.10
C1	-	5.25	-
D	0.30	0.35	0.40
E	-	1.00	1.10
E1	-	0.75	-
E2	0.20	0.25	0.30
R	-	-	0.08

NOTE.

1. DIMENSIONING AND TOLERANCING PER ASME Y14.5M-1994.
2. ALL DIMENSIONS ARE MILLIMETERS.
3. DIMENSION "D" IS MEASURED AT THE MAXIMUM SOLDER BALL DIAMETER IN A PLANE PARALLEL TO DATUM C.
4. PRIMARY DATUM C(SEATING PLANE) IS DEFINED BY THE CROWN OF THE SOLDER BALLS.
5. THIS IS A CONTROLLING DIMENSION.

MARKING INFORMATION

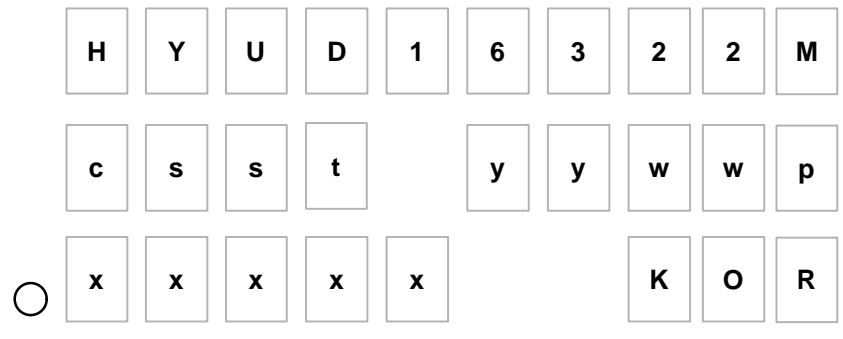
Package	Marking Example
FBGA	

Index

<ul style="list-style-type: none"> • HYUD16322M : Part Name HY : HYNIX U : Power Supply : 3.0V(2.7V~3.3V) D : Tech. + Classification : 1T+1C 16 : Bit Organization : x16 32 : Density : 32M 2 : Mode : 1CS with /UB,/LB;tCS M : Version : 1st Generation 	
<ul style="list-style-type: none"> • c : Power Consumption : D – Low Low Power • ss : Speed : 70 – 70ns 85 – 85ns • t : Temperature : E – Extended(-25 ~ 85°C) I – Industrial(-40 ~ 85°C) 	
<ul style="list-style-type: none"> • yy : Year (ex : 01 = year 2001, 02= year 2002) • ww : Work Week (ex : 12 = work week 12) • p : Process Code 	
<ul style="list-style-type: none"> • xxxxx : Lot No. • KOR : Origin Country 	
<p>Note</p> <ul style="list-style-type: none"> - Capital Letter : Fixed Item - Small Letter : Non-fixed Item 	