



ICS650-01B System Peripheral Clock Source

Description

The ICS650-01B is a low cost, low jitter, high performance clock synthesizer for system peripheral applications. Using analog/digital Phase-Locked Loop (PLL) techniques, the device accepts a parallel resonant 14.31818 MHz crystal input to produce up to eight output clocks. The device provides clocks for PCI, SCSI, Fast Ethernet, Ethernet, and AC97. The user can select from multiple interface frequencies, and also one of three AC97 audio frequencies. The OE pin puts all outputs into a high impedance state for board level testing. All frequencies are generated with less than one ppm error, meeting the demands of SCSI and Ethernet clocking.

The ICS650 can be mask customized to produce any frequencies from 1 to 150 MHz.

Features

- Packaged in 20 pin tiny SSOP (QSOP) 
- ^a Operating VDD of 3.3V or 5V
- Less than one ppm synthesis error in all clocks
- Inexpensive 14.31818 MHz crystal or clock input
- Provides Ethernet and Fast Ethernet clocks
- Provides SCSI clocks
- Provides PCI clocks
- Selectable AC97 audio clock
- Selectable interface clock
- OE pin tri-states the outputs for testing
- Selectable frequencies on three clocks
- Duty cycle of 40/60
- Advanced, low power CMOS process

Block Diagram

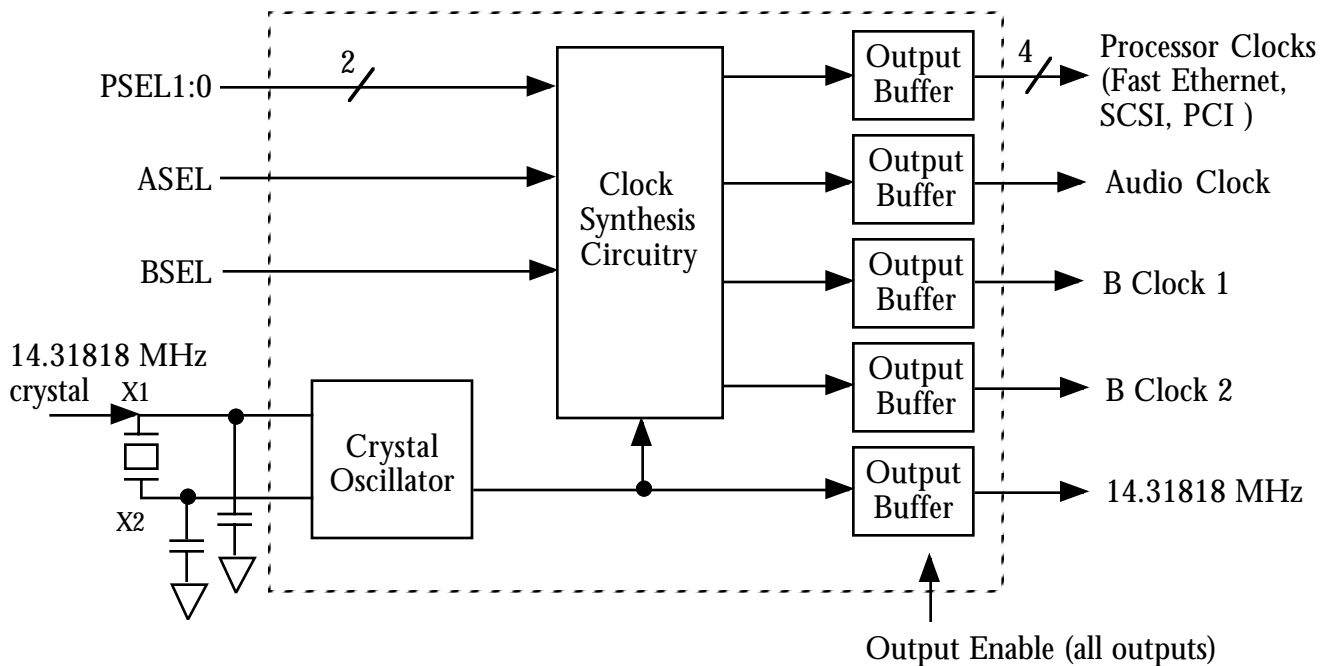



ICS650-01B

System Peripheral Clock Source

Pin Assignment

BSEL	□ 1	20	□ PSEL1
X2	□ 2	19	□ PSEL0
X1	□ 3	18	□ PCLK2
VDD	□ 4	17	□ PCLK3
GND	□ 5	16	□ VDD
GND	□ 6	15	□ ASEL
BCLK1	□ 7	14	□ GND
BCLK2	□ 8	13	□ 14.318M
ACLK	□ 9	12	□ PCLK1
PCLK4	□ 10	11	□ OE

20 pin (150 mil) SSOP

Processor Clock (MHz)

PSEL1	PSEL0	PCLK1	PCLK2,3	PCLK4
0	0	25.00	50.00	18.75
0	M	TEST	TEST	TEST
0	1	TEST	TEST	TEST
M	0	40.00	80.00	20.00
M	M	33.3334	66.6667	25.00
M	1	20.00	40.00	25.00
1	0	20.00	33.3334	25.00
1	M	20.00	66.6667	25.00
1	1	Stops low all clocks except BCLK2.		

B Clocks (MHz)

BSEL	BCLK1	BCLK2
0	3.688	4.917
M	50	25
1	80	40

Audio Clock (MHz)

ASEL	ACLK
0	49.152
M	24.576
1	12.288

0 = connect directly to ground, 1 = connect directly to VDD, M=leave unconnected (floating)

Pin Descriptions

Pin #	Name	Type	Description
1	BSEL	I	BCLK1 and BCLK2 Select pin. Determines frequency of B clocks per table above.
2	X2	XO	Crystal connection. Connect to parallel mode 14.31818 MHz crystal. Leave open for clock.
3	X1	XI	Crystal connection. Connect to parallel mode 14.31818 MHz crystal, or clock.
4	VDD	P	Connect to VDD. Must be same value as other VDD. Decouple with pin 6.
5	GND	P	Connect to ground.
6	GND	P	Connect to ground.
7	BCLK1	O	BCLK1 output. Determined by BSEL pin per table above.
8	BCLK2	O	BCLK2 output. Determined by BSEL pin per table above. Only clock active if PSEL1, 0=1.
9	ACLK	O	AC97 Audio clock output per table above.
10	PCLK4	O	PCLK output number 4 per table above.
11	OE	I	Output Enable. Tri-states all outputs when low.
12	PCLK1	O	PCLK output number 1 per table above.
13	14.318M	O	14.31818 MHz buffered reference clock output.
14	GND	P	Connect to ground.
15	ASEL	I	ACLK Select pin. Determines frequency of Audio clock per table above.
16	VDD	P	Connect to VDD. Must be same value as other VDD. Decouple with pin 14.
17	PCLK3	O	PCLK output number 3 per table above.
18	PCLK2	O	PCLK output number 2 per table above.
19	PSEL0	I	Processor Select pin #0. Determines frequencies on PCLKs 1-4 per table above.
20	PSEL1	I	Processor Select pin #1. Determines frequencies on PCLKs 1-4 per table above.

Key: I = Input; XO/XI = crystal connections; O = output; P = power supply connection



ICS650-01B

System Peripheral Clock Source

Electrical Specifications

Parameter	Conditions	Minimum	Typical	Maximum	Units
ABSOLUTE MAXIMUM RATINGS (note 1)					
Supply voltage, VDD	Referenced to GND			7	V
Inputs and Clock Outputs	Referenced to GND	-0.5		VDD+0.5	V
Ambient Operating Temperature		0		70	°C
Soldering Temperature	Max of 10 seconds			260	°C
Storage temperature		-65		150	°C
DC CHARACTERISTICS (VDD = 3.3V or 5V unless noted)					
Operating Voltage, VDD		3.0		5.5	V
Input High Voltage, VIH	Select inputs, OE	2			V
Input Low Voltage, VIL	Select inputs, OE			0.8	V
Output High Voltage, VOH	VDD=3.3V, IOH=-8mA	2.4			V
Output Low Voltage, VOL	VDD=3.3V, IOL=8mA			0.4	V
Output High Voltage, VOH, VDD = 3.3 or 5V	IOH=-8mA	VDD-0.4			V
Operating Supply Current, IDD, at 5V	No Load, note 2		50		mA
Operating Supply Current, IDD, at 3.3V	No Load, note 2		25		mA
Short Circuit Current, VDD = 3.3	Each output		±50		mA
Input Capacitance	Except X1		7		pF
AC CHARACTERISTICS (VDD = 3.3V or 5V unless noted)					
Input Crystal or Clock Frequency			14.31818		MHz
Output Clocks Accuracy (synthesis error)	All clocks			1	ppm
Output Clock Rise Time	0.8 to 2.0V			1.5	ns
Output Clock Fall Time	2.0 to 0.8V			1.5	ns
Output Clock Duty Cycle	At VDD/2	40	50	60	%
One Sigma Jitter	Except ACLK		75		ps
One Sigma Jitter	ACLK		170		ps
Absolute Clock Period Jitter	PCLK, UCLK, BCLK	- 500		500	ps

- Notes: 1. Stresses beyond those listed under Absolute Maximum Ratings could cause permanent damage to the device. Prolonged exposure to levels above the operating limits but below the Absolute Maximums may affect device reliability.
 2. With all clocks at highest frequencies.

External Components

The ICS650 requires a minimum number of external components for proper operation. Decoupling capacitors of 0.01μF should be connected between VDD and GND (on pins 4 and 6, and pins 16 and 14), as close to the chip as possible. A series termination resistor of 33 Ω may be used for each clock output. The 14.31818 MHz crystal must be connected as close to the chip as possible. The crystal should be a fundamental mode, parallel resonant, 30 ppm or better (to meet the Ethernet specs). Crystal capacitors should be connected from pins X1 to ground and X2 to ground. The value of these capacitors is given by the following equation, where C_L is the crystal load capacitance: Crystal caps (pF) = $(C_L - 12) \times 2$. So for a crystal with 16pF load capacitance, two 8pF caps should be used. If a clock input is used, drive it into X1 and leave X2 unconnected.



Package Outline and Package Dimensions

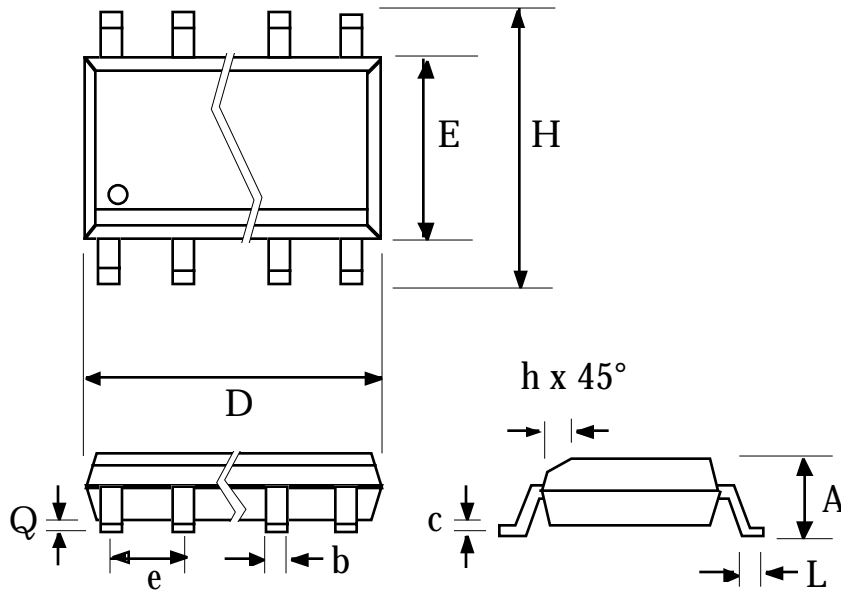

20 pin SSOP

Symbol	Millimeters	
	Min	Max
A	1.55	1.73
b	0.203	0.305
c	0.190	0.254
D	8.560	8.740
E	3.810	4.000
H	5.840	6.200
e	0.635 BSC	
h		0.410
L	0.016	0.035
Q	0.127	0.250

Ordering Information

Part/Order Number	Marking	Package	Shipping	Temperature
ICS650R-01	ICS650R-01	20 pin SSOP	Tubes	0 to 70 °C
ICS650R-01T	ICS650R-01	20 pin SSOP	Tape and Reel	0 to 70 °C
ICS650R-01I	ICS650R01I	20 pin SSOP	Tubes	-40 to 85 °C
ICS650R-01IT	ICS650R01I	20 pin SSOP	Tape and Reel	-40 to 85 °C

While the information presented herein has been checked for both accuracy and reliability, Integrated Circuit Systems, Incorporated (ICS) assumes no responsibility for either its use or for the infringement of any patents or other rights of third parties, which would result from its use. No other circuits, patents, or licenses are implied. This product is intended for use in normal commercial applications. Any other applications such as those requiring extended temperature range, high reliability, or other extraordinary environmental requirements are not recommended without additional processing by ICS. ICS reserves the right to change any circuitry or specifications without notice. ICS does not authorize or warrant any ICS product for use in life support devices or critical medical instruments.