

IR3080

***XPHASE*TM VRD10 CONTROL IC WITH VCCVID & OVERTEMP DETECT**

DESCRIPTION

The IR3080 Control IC combined with an IR *XPhase*TM Phase IC provides a full featured and flexible way to implement a complete VRD 10 power solution. The “Control” IC provides overall system control and interfaces with any number of “Phase ICs” which each drive and monitor a single phase of a multiphase converter. The *XPhase*TM architecture results in a power supply that is smaller, less expensive, and easier to design while providing higher efficiency than conventional approaches.

The IR3080 is intended for desktop applications and includes the VCCVID and VRHOT functions required for proper system operation.

FEATURES

- 6 bit VR10 compatible VID with 0.5% overall system accuracy
- 1 to X phases operation with matching phase ICs
- On-chip 700Ω VID Pull-up resistors with VID pull-up voltage input
- Programmable Dynamic VID Slew Rate
- No Discharge of output capacitors during Dynamic VID step-down (can be disabled)
- +/-300mV Differential Remote Sense
- Programmable 150kHz to 1MHz oscillator
- Programmable VID Offset and Load Line output impedance
- Programmable Softstart
- Programmable Hiccup Over-Current Protection with Delay to prevent false triggering
- Simplified Powergood provides indication of proper operation and avoids false triggering
- Operates from 12V input with 9.1V Under-Voltage Lockout
- 6.8V/5mA Bias Regulator provides System Reference Voltage
- 1.2V @ 150mA VCCVID Linear Regulator with Full Protection
- VCCVID Powergood with Programmable delay gates converter operation
- Programmable Converter Over-Temperature Detection and Output
- Small thermally enhanced 32L MLPQ package

PACKAGE PIN OUT

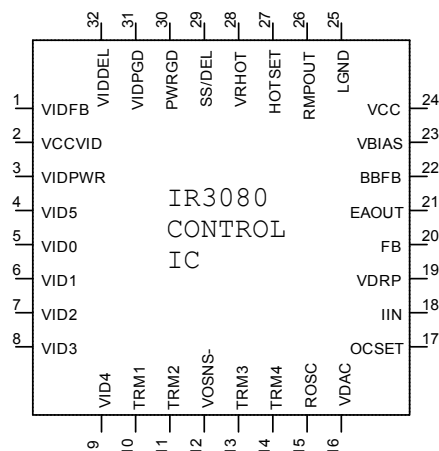

ORDERING INFORMATION

Device	Order Quantity
IR3080MTR	3000 per reel
* IR3080M	100 piece strips

* Samples only

ABSOLUTE MAXIMUM RATINGS

Operating Junction Temperature.....150°C
 Storage Temperature Range.....-65°C to 150°C
 ESD Rating.....HBM Class 1C JEDEC standard

PIN #	PIN NAME	V _{MAX}	V _{MIN}	I _{SOURCE}	I _{SINK}
1	VIDFB	20V	-0.3V	1mA	1mA
2	VCCVID	20V	-0.5V	400mA	50mA
3	VIDPWR	20V	-0.3V	1mA	400mA
4-9	VID0-5	20V	-0.3V	10mA	10mA
10, 11, 13,14	TRM1-4	Do Not Connect	Do Not Connect	Do Not Connect	Do Not Connect
12	VOSNS-	0.5V	-0.5V	10mA	10mA
15	ROSC	20V	-0.5V	1mA	1mA
16	VDAC	20V	-0.3V	1mA	1mA
17	OCSET	20V	-0.3V	1mA	1mA
18	IIN	20V	-0.3V	1mA	1mA
19	VDRP	20V	-0.3V	5mA	5mA
20	FB	20V	-0.3V	1mA	1mA
21	EAOUT	10V	-0.3V	10mA	20mA
22	BBFB	20V	-0.3V	1mA	1mA
23	VBIAS	20V	-0.3V	1mA	1mA
24	VCC	20V	-0.3V	1mA	50mA
25	LGND	n/a	n/a	50mA	1mA
26	RMPOUT	20V	-0.3V	1mA	1mA
27	HOTSET	20V	-0.3V	1mA	1mA
28	VRHOT	20V	-0.3V	1mA	50mA
29	SS/DEL	20V	-0.3V	1mA	1mA
30	PWRGD	20V	-0.3V	1mA	20mA
31	VIDPGD	20V	-0.3V	1mA	20mA
32	VIDDEL	20V	-0.3V	1mA	1mA

ELECTRICAL SPECIFICATIONS

Unless otherwise specified, these specifications apply over: $9.5V \leq V_{CC} \leq 14V$, $2.0V \leq VIDPWR \leq 5.5V$ and $0^\circ C \leq T_J \leq 100^\circ C$

PARAMETER	TEST CONDITION	MIN	TYP	MAX	UNIT
VDAC Reference					
System Set-Point Accuracy	$-0.3V \leq VOSNS- \leq 0.3V$, Connect FB to EAOUT, Measure $V(EAOUT) - V(VOSNS-)$ deviation from Table 1. Applies to all VID codes.		0.5		%
Source Current	$R_{ROSC} = 41.9k\Omega$	68	80	92	μA
Sink Current	$R_{ROSC} = 41.9k\Omega$	47	55	63	μA
VID Input Threshold		500	600	700	mV
VID Pull-up Resistors		500	700	1000	Ω
Regulation Detect Comparator Input Offset		-5	0	5	mV
Regulation Detect to EAOUT Delay			130	200	ns
BBFB to FB Bias Current Ratio		0.95	1.00	1.05	$\mu A/\mu A$
VID 1111x Blanking Delay	Measure time until PWRGD drives low		800		ns
VID Step Down Detect Blanking Time	Measure from VID inputs to EAOUT		1.7		μs
VID Down BB Clamp Voltage	Percent of VDAC voltage	70	75	80	%
VID Down BB Clamp Current		3.5	6.2	12	mA
Error Amplifier					
Input Offset Voltage	Connect FB to EAOUT, Measure $V(EAOUT) - V(DAC)$. from Table 1. Applies to all VID codes and $-0.3V \leq VOSNS- \leq 0.3V$. Note 2	-3	4	8	mV
FB Bias Current	$R_{ROSC} = 41.9k\Omega$	-31	-29.5	-28	μA
DC Gain	Note 1	90	100	105	dB
Gain-Bandwidth Product	Note 1	4	7		MHz
Source Current		0.4	0.6	0.8	mA
Sink Current		0.7	1.2	1.7	mA
Max Voltage	$VBIAS - VEAOUT$ (referenced to VBIAS)	125	250	375	mV
Min Voltage	Normal operation or Fault mode	30	100	150	mV
VDRP Buffer Amplifier					
Input Offset Voltage	$V(VDRP) - V(IIN)$, $0.8V \leq V(IIN) \leq 5.5V$	-8	0	8	mV
Input Voltage Range		0.8		5.5	V
Bandwidth (-3dB)	Note 1	1	6		MHz
Slew Rate			10		V/ μs
IIN Bias Current		-2.0	-0.75	0	μA

PARAMETER	TEST CONDITION	MIN	TYP	MAX	UNIT
Oscillator					
Switching Frequency	$R_{ROSC} = 41.9k\Omega$	255	300	345	kHz
Peak Voltage (5V typical, measured as % of VBIAS)	$R_{ROSC} = 41.9k\Omega$	70	71	74	%
Valley Voltage (1V typical, measured as % of VBIAS)	$R_{ROSC} = 41.9k\Omega$	11	14	16	%
VBIAS Regulator					
Output Voltage	$-5mA \leq I(VBIAS) \leq 0$	6.5	6.8	7.1	V
Current Limit		-30	-15	-6	mA
Soft Start and Delay					
SS/DEL to FB Input Offset Voltage	With FB = 0V, adjust V(SS/DEL) until EAOUT drives high	0.85	1.3	1.5	V
Charge Current		40	70	100	μA
Discharge Current		4	6	9	μA
Charge/Discharge Current Ratio		10	11.5	13	$\mu A/\mu A$
Charge Voltage		3.7	4.0	4.2	V
Delay Comparator Threshold	Relative to Charge Voltage	70	90	110	mV
Discharge Comparator Threshold		150	200	250	mV
Over-Current Comparator					
Input Offset Voltage		-10	0	10	mV
OCSET Bias Current	$R_{ROSC} = 41.9k\Omega$	-31	-29.5	-28	μA
PWRGD Output					
Output Voltage	$I(PWRGD) = 4mA$		150	400	mV
Leakage Current	$V(PWRGD) = 5.5V$		0	10	μA
VCCVID Regulator					
Output Voltage	$-150mA \leq I(VCCVID) \leq 0$	1.145	1.200	1.215	V
Dropout Voltage	$I(VCCVID) = -20mA$		130	200	mV
	$I(VCCVID) = -150mA$		0.8	1.0	V
Current Limit			-300		mA
VIDFB Bias Current		-225	-150		μA
VCCVID Powergood					
VCCVID Threshold Voltage	Relative to regulated VCCVID Output Voltage	1.05	1.10	1.13	V
Charge Current		30	66	90	μA
Discharge Current		4	7	11	mA
Charge Voltage		3.7	4.0	4.2	V
Delay Comparator Threshold	Relative to Charge Voltage	65	90	115	mV
VIDPGD Output Voltage	$I(VIDPGD) = 4mA$		150	400	mV
VIDPGD Leakage Current	$V(VIDPGD) = 5.5V$		0	10	μA

PARAMETER	TEST CONDITION	MIN	TYP	MAX	UNIT
VCC Under-Voltage Lockout					
Start Threshold		8.6	9.1	9.6	V
Stop Threshold		8.4	8.9	9.4	V
Hysteresis	Start – Stop	150	200	300	mV
General					
VCC Supply Current		8	11	14	mA
VIDPWR Supply Current	VID0-5 Open, I(VCCVID) = 0	400	550	1000	μA
VOSNS- Current	-0.3V ≤ VOSNS- ≤ 0.3V, All VID Codes	-5.5	-4.5	-3.5	mA
VRHOT Comparator					
HOTSET Bias Current		-2	-0.5	1	μA
Output Voltage	I(VRHOT) = 29mA		300	400	mV
VRHOT Leakage Current	V(VRHOT) = 5.5V		0	10	μA
Threshold Hysteresis	T _J ≥ 85°C	3	6	10	°C
		MIN	TYP	MAX	
Threshold Voltage (increasing temperature)	T _J ≥ 85°C	4.73mV/°C x T _J + 1.176V	4.73mV/°C x T _J + 1.241V	4.73mV/°C x T _J + 1.356V	V

Note 1: Guaranteed by design, but not tested in production

Note 2: VDAC Output is trimmed to compensate for Error Amplifier input offsets errors

PIN DESCRIPTION

PIN#	PIN SYMBOL	PIN DESCRIPTION
1	VIDFB	Feedback to the VCCVID regulator. Connect to the VCCVID output.
2	VCCVID	1.2V/150mA Regulator Output. Can also drive external pass transistor to minimize on-chip power dissipation
3	VIDPWR	Power for VID Pull-up resistors and VCCVID Regulator
4-9	VID0-5	Inputs to VID D to A Converter. On-chip 700 ohm pull-up resistors to VIDPWR pin are included.
10, 11, 13,14	TRM1-4	Used for precision post-package trimming of the VDAC voltage. Do not make any connection to these pins.
12	VOSNS-	Remote Sense Input. Connect to ground at the Load.
15	ROSC	Connect a resistor to VOSNS- to program oscillator frequency and FB, OCSET, BBFB, and VDAC bias currents
16	VDAC	Regulated voltage programmed by the VID inputs. Current Sensing and PWM operation are referenced to this pin. Connect an external RC network to VOSNS- to program Dynamic VID slew rate.
17	OCSET	Programs the hiccup over-current threshold through an external resistor tied to VDAC and an internal current source. Over-current protection can be disabled by connecting this pin to a DC voltage no greater than 6.5V (do not float this pin as improper operation will occur).
18	IIN	Current Sense input from the Phase IC(s). To ensure proper operation bias to at least 250mV (don't float this pin).
19	VDRP	Buffered IIN signal. Connect an external RC network to FB to program converter output impedance
20	FB	Inverting input to the Error Amplifier. Converter output voltage is offset from the VDAC voltage through an external resistor connected to the converter output voltage at the load and an internal current source.
21	EAOUT	Output of the Error Amplifier
22	BBFB	Input to the Regulation Detect Comparator. Connect to converter output voltage and VDRP pin through resistor network to program recovery from VID step-down. Connect to ground to disable Body Braking™ during transition to a lower VID code.
23	VBIAS	6.8V/5mA Regulated output used as a system reference voltage for internal circuitry and the Phase ICs
24	VCC	Power for internal circuitry
25	LGND	Local Ground and IC substrate connection
26	RMPOUT	Oscillator Output voltage. Used by Phase ICs to program Phase Delay
27	HOTSET	Inverting input to VRHOT comparator. Connect resistor divider from VBIAS to LGND to program VRHOT threshold. Diode or thermistor may be substituted for lower resistor for enhanced/remote temperature sensing. Applying a voltage exceeding approximately 7.5V disables the oscillator for factory testing.
28	VRHOT	Open Collector output of the VRHOT comparator. Connect external pull-up.
29	SS/DEL	Controls Converter Softstart, Power Good, and Over-Current Delay Timing. Connect an external capacitor to LGND to program the timing. An optional resistor can be added in series with the capacitor to reduce the over-current delay time.
30	PWRGD	Open Collector output that drives low during Softstart and any external fault condition. Connect external pull-up.
31	VIDPGD	Open Collector output of the VCCVID Power Good circuitry. Connect external pull-up.
32	VIDDEL	Connect an external capacitor to LGND to program the VCCVID Power Good delay

SYSTEM THEORY OF OPERATION

XPhase™ Architecture

The XPhase™ architecture is designed for multiphase interleaved buck converters which are used in applications requiring small size, design flexibility, low voltage, high current and fast transient response. The architecture can control converters of any phase number where flexibility facilitates the design trade-off of multiphase converters. The scalable architecture can be applied to other applications which require high current or multiple output voltages.

As shown in Figure 1, the XPhase™ architecture consists of a Control IC and a scalable array of phase converters each using a single Phase IC. The Control IC communicates with the Phase ICs through a 5-wire analog bus, i.e. bias voltage, phase timing, average current, error amplifier output, and VID voltage. The Control IC incorporates all the system functions, i.e. VID, PWM ramp oscillator, error amplifier, bias voltage, and fault protections etc. The Phase IC implements the functions required by the converter of each phase, i.e. the gate drivers, PWM comparator and latch, over-voltage protection, and current sensing and sharing.

There is no unused or redundant silicon with the XPhase™ architecture compared to others such as a 4 phase controller that can be configured for 2, 3, or 4 phase operation. PCB Layout is easier since the 5 wire bus eliminates the need for point-to-point wiring between the Control IC and each Phase. The critical gate drive and current sense connections are short and local to the Phase ICs. This improves the PCB layout by lowering the parasitic inductance of the gate drive circuits and reducing the noise of the current sense signal.

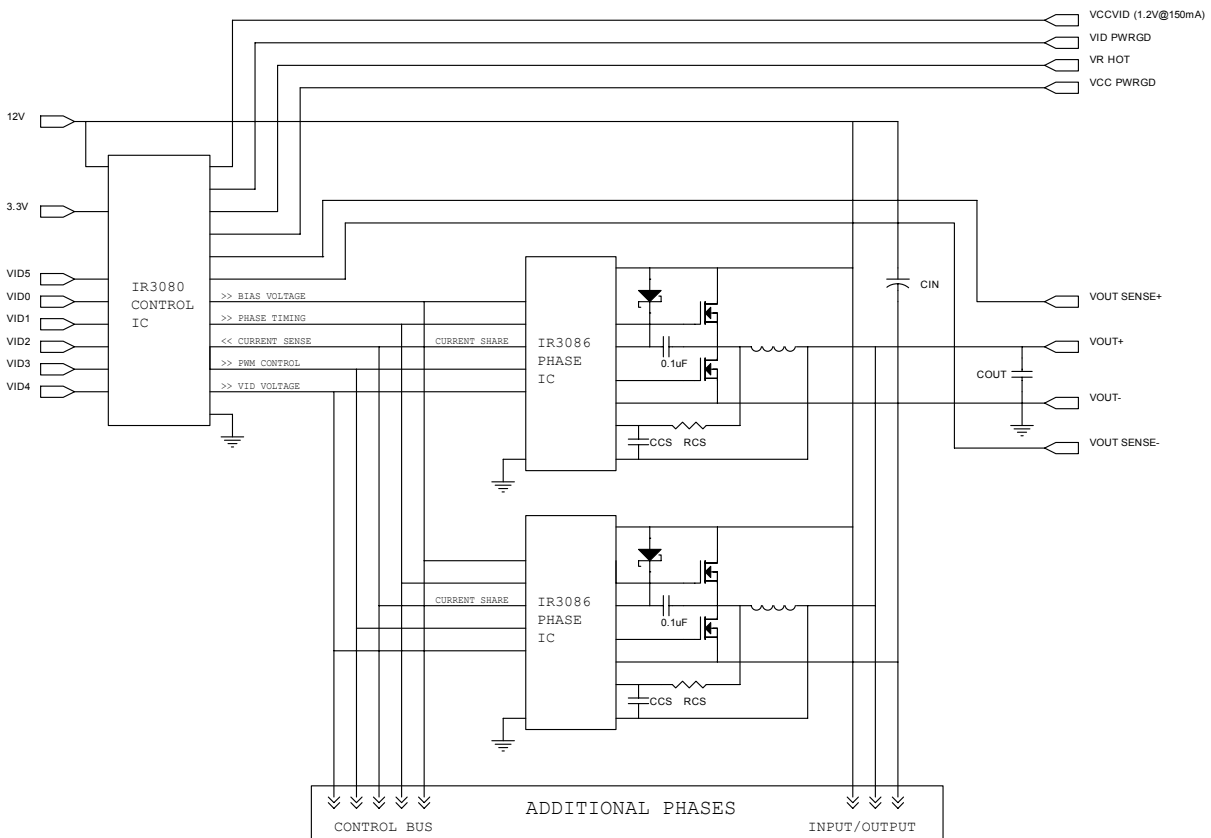

Figure 1. System Block Diagram

PWM Control Method

The PWM block diagram of the *XPhase*TM architecture is shown in Figure 2. Feed-forward voltage mode control with trailing edge modulation is used. A high-gain wide-bandwidth voltage type error amplifier in the Control IC is used for the voltage control loop. An external RC circuit connected to the input voltage and ground is used to program the slope of the PWM ramp and to provide the feed-forward control at each phase. The PWM ramp slope will change with the input voltage and automatically compensate for changes in the input voltage. The input voltage can change due to variations in the silver box output voltage or due to wire and PCB-trace voltage drop related to changes in load current.

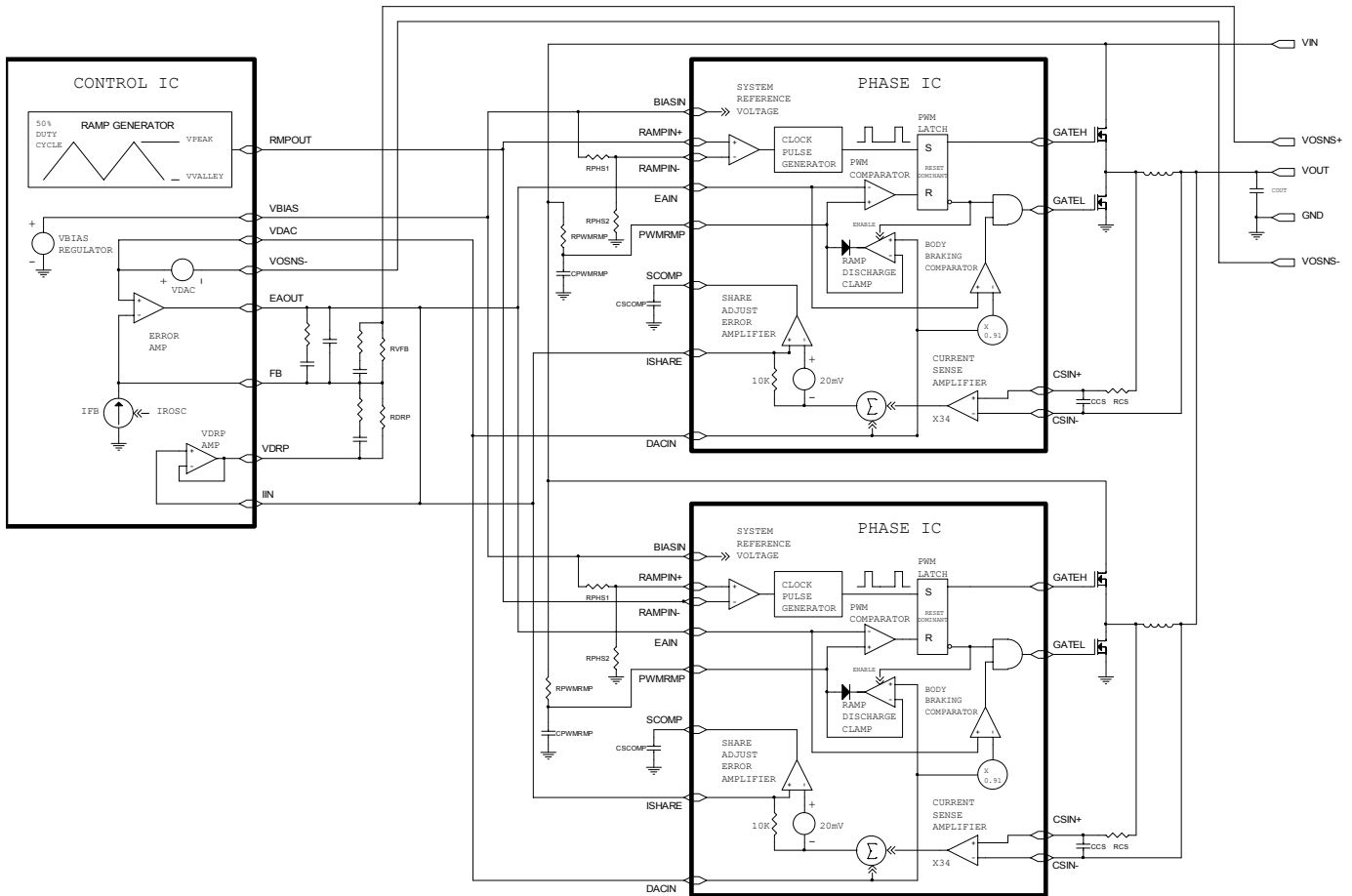

Figure 2. PWM Block Diagram

Frequency and Phase Timing Control

The oscillator is located in the Control IC and its frequency is programmable from 150kHz to 1MHz by an external resistor. The output of the oscillator is a 50% duty cycle triangle waveform with peak and valley voltages of approximately 5V and 1V respectively. This signal is used to program both the switching frequency and phase timing of the Phase ICs. The Phase IC is programmed by resistor divider RPHS1 and RPHS2 connected between the VBIAS reference voltage and the Phase IC LGND pin. A comparator in the Phase ICs detects the crossing of the oscillator waveform over the voltage generated by the resistor divider and triggers a clock pulse that starts the PWM cycle. The peak and valley voltages track the VBIAS voltage reducing potential Phase IC timing errors. Figure 3 shows the Phase timing for an 8 phase converter. Note that both slopes of the triangle waveform can be used for phase timing by swapping the RMPIN+ and RMPIN- pins, as shown in Figure 2.

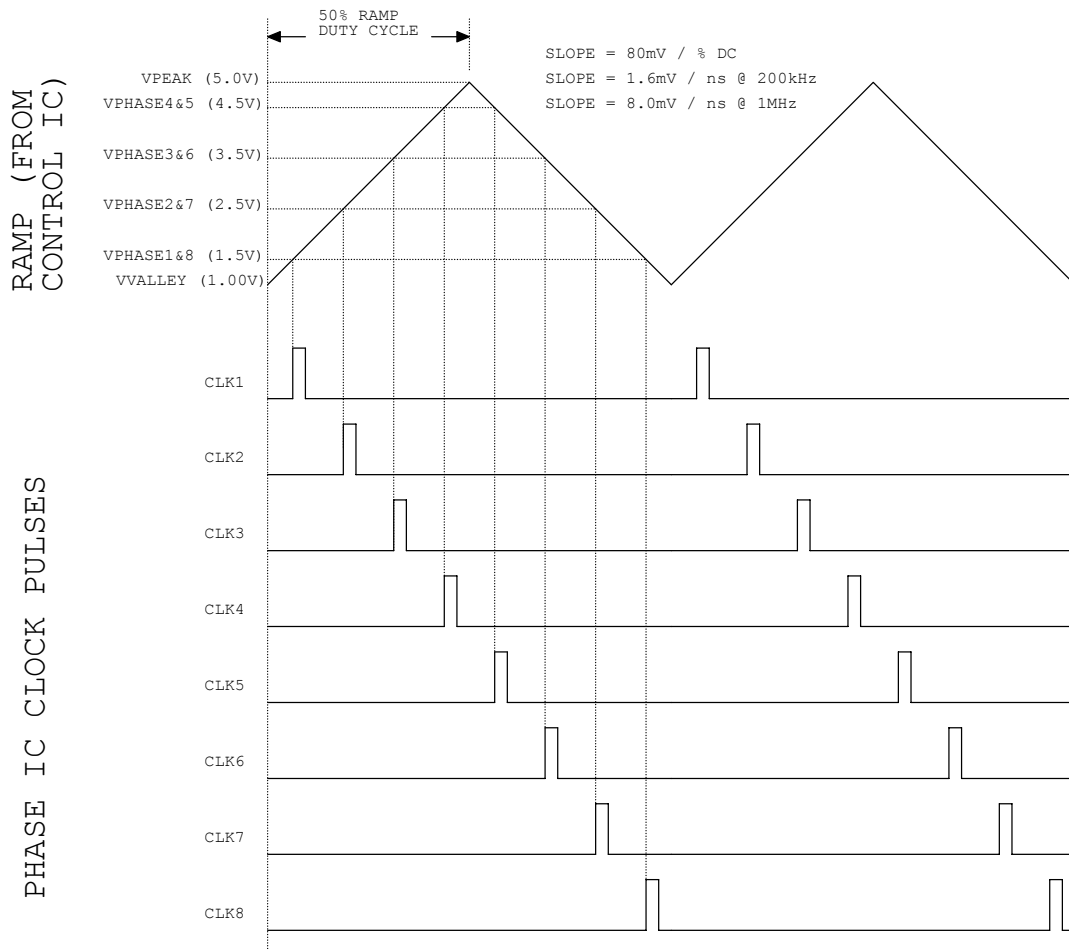

Figure 3. 8 Phase Oscillator Waveforms

PWM Operation

The PWM comparator is located in the Phase IC. Upon receiving a clock pulse, the PWM latch is set; the PWMRMP voltage begins to increase; the low side driver is turned off, and the high side driver is then turned on after the non-overlap time. When the PWMRMP voltage exceeds the Error Amplifier’s output voltage, the PWM latch is reset. This turns off the high side driver and then turns on the low side driver after the non-overlap time; it activates the Ramp Discharge Clamp, which quickly discharges the PWMRMP capacitor to the VDAC voltage of the Control IC until the next clock pulse.

The PWM latch is reset dominant allowing all phases to go to zero duty cycle within a few tens of nanoseconds in response to a load step decrease. Phases can overlap and go to 100% duty cycle in response to a load step increase with turn-on gated by the clock pulses. An Error Amplifier output voltage greater than the common mode input range of the PWM comparator results in 100% duty cycle regardless of the voltage of the PWM ramp. This arrangement guarantees the Error Amplifier is always in control and can demand 0 to 100% duty cycle as required. It also favors response to a load step decrease which is appropriate given the low output to input voltage ratio of most systems. The inductor current will increase much more rapidly than decrease in response to load transients.

This control method is designed to provide “single cycle transient response” where the inductor current changes in response to load transients within a single switching cycle maximizing the effectiveness of the power train and minimizing the output capacitor requirements. An additional advantage of the architecture is that differences in ground or input voltage at the phases have no effect on operation since the PWM ramps are referenced to VDAC.

Figure 4 depicts PWM operating waveforms under various conditions.

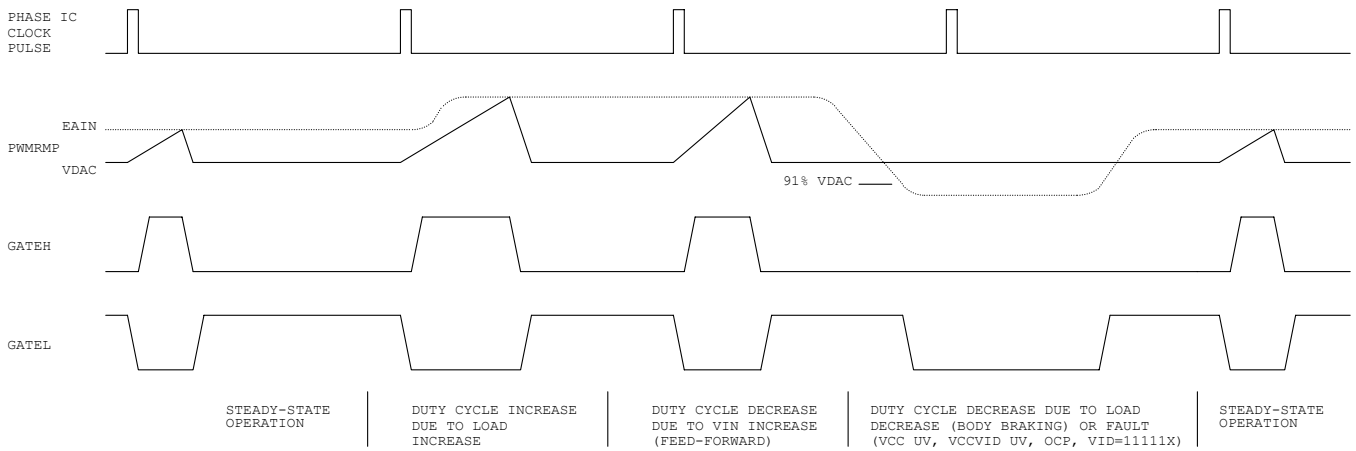

Figure 4. PWM Operating Waveforms

Body Braking™

In a conventional synchronous buck converter, the minimum time required to reduce the current in the inductor in response to a load step decrease is;

$$T_{SLEW} = \frac{L * (I_{MAX} - I_{MIN})}{V_O}$$

The slew rate of the inductor current can be significantly increased by turning off the synchronous rectifier in response to a load step decrease. The switch node voltage is then forced to decrease until conduction of the synchronous rectifier's body diode occurs. This increases the voltage across the inductor from V_{out} to $V_{out} + V_{BODYDIODE}$. The minimum time required to reduce the current in the inductor in response to a load transient decrease is now;

$$T_{SLEW} = \frac{L * (I_{MAX} - I_{MIN})}{V_O + V_{BODYDIODE}}$$

Since the voltage drop in the body diode is often higher than output voltage, the inductor current slew rate can be increased by 2X or more. This patent pending technique is referred to as "body braking" and is accomplished through the "0% Duty Cycle Comparator" located in the Phase IC. If the Error Amplifier's output voltage drops below 91% of the VDACC voltage this comparator turns off the low side gate driver.

Lossless Average Inductor Current Sensing

Inductor current can be sensed by connecting a series resistor and a capacitor network in parallel with the inductor and measuring the voltage across the capacitor, as shown in Figure 5. The equation of the sensing network is,

$$v_C(s) = v_L(s) \frac{1}{1 + sR_{CS}C_{CS}} = i_L(s) \frac{R_L + sL}{1 + sR_{CS}C_{CS}}$$

Usually the resistor R_{CS} and capacitor C_{CS} are chosen so that the time constant of R_{CS} and C_{CS} equals the time constant of the inductor which is the inductance L over the inductor DCR. If the two time constants match, the voltage across C_{CS} is proportional to the current through L , and the sense circuit can be treated as if only a sense resistor with the value of R_L was used. The mismatch of the time constants does not affect the measurement of inductor DC current, but affects the AC component of the inductor current.

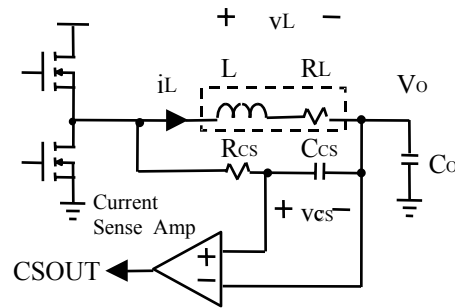

Figure 5. Inductor Current Sensing and Current Sense Amplifier

The advantage of sensing the inductor current versus high side or low side sensing is that actual output current being delivered to the load is obtained rather than peak or sampled information about the switch currents. The output voltage can be positioned to meet a load line based on real time information. Except for a sense resistor in series with the inductor, this is the only sense method that can support a single cycle transient response. Other methods provide no information during either load increase (low side sensing) or load decrease (high side sensing).

An additional problem associated with peak or valley current mode control for voltage positioning is that they suffer from peak-to-average errors. These errors will show in many ways but one example is the effect of frequency variation. If the frequency of a particular unit is 10% low, the peak to peak inductor current will be 10% larger and the output impedance of the converter will drop by about 10%. Variations in inductance, current sense amplifier bandwidth, PWM prop delay, any added slope compensation, input voltage, and output voltage are all additional sources of peak-to-average errors.

Current Sense Amplifier

A high speed differential current sense amplifier is located in the Phase IC, as shown in Figure 5. Its gain decreases with increasing temperature and is nominally 34 at 25°C and 29 at 125°C (-1470 ppm/°C). This reduction of gain tends to compensate the 3850 ppm/°C increase in inductor DCR. Since in most designs the Phase IC junction is hotter than the inductors these two effects tend to cancel such that no additional temperature compensation of the load line is required.

The current sense amplifier can accept positive differential input up to 100mV and negative up to -20mV before clipping. The output of the current sense amplifier is summed with the DAC voltage and sent to the Control IC and other Phases through an on-chip 10KΩ resistor connected to the ISHARE pin. The ISHARE pins of all the phases are tied together and the voltage on the share bus represents the average current through all the inductors and is used by the Control IC for voltage positioning and current limit protection.

Average Current Share Loop

Current sharing between phases of the converter is achieved by the average current share loop in each Phase IC. The output of the current sense amplifier is compared with the share bus less a 20mV offset. If current in a phase is smaller than the average current, the share adjust amplifier of the phase will activate a current source that reduces the slope of its PWM ramp thereby increasing its duty cycle and output current. The crossover frequency of the current share loop can be programmed with a capacitor at the SCOMP pin so that the share loop does not interact with the output voltage loop.

IR3080 THEORY OF OPERATION

Block Diagram

The Block diagram of the IR3080 is shown in Figure 6, and specific features are discussed in the following sections.

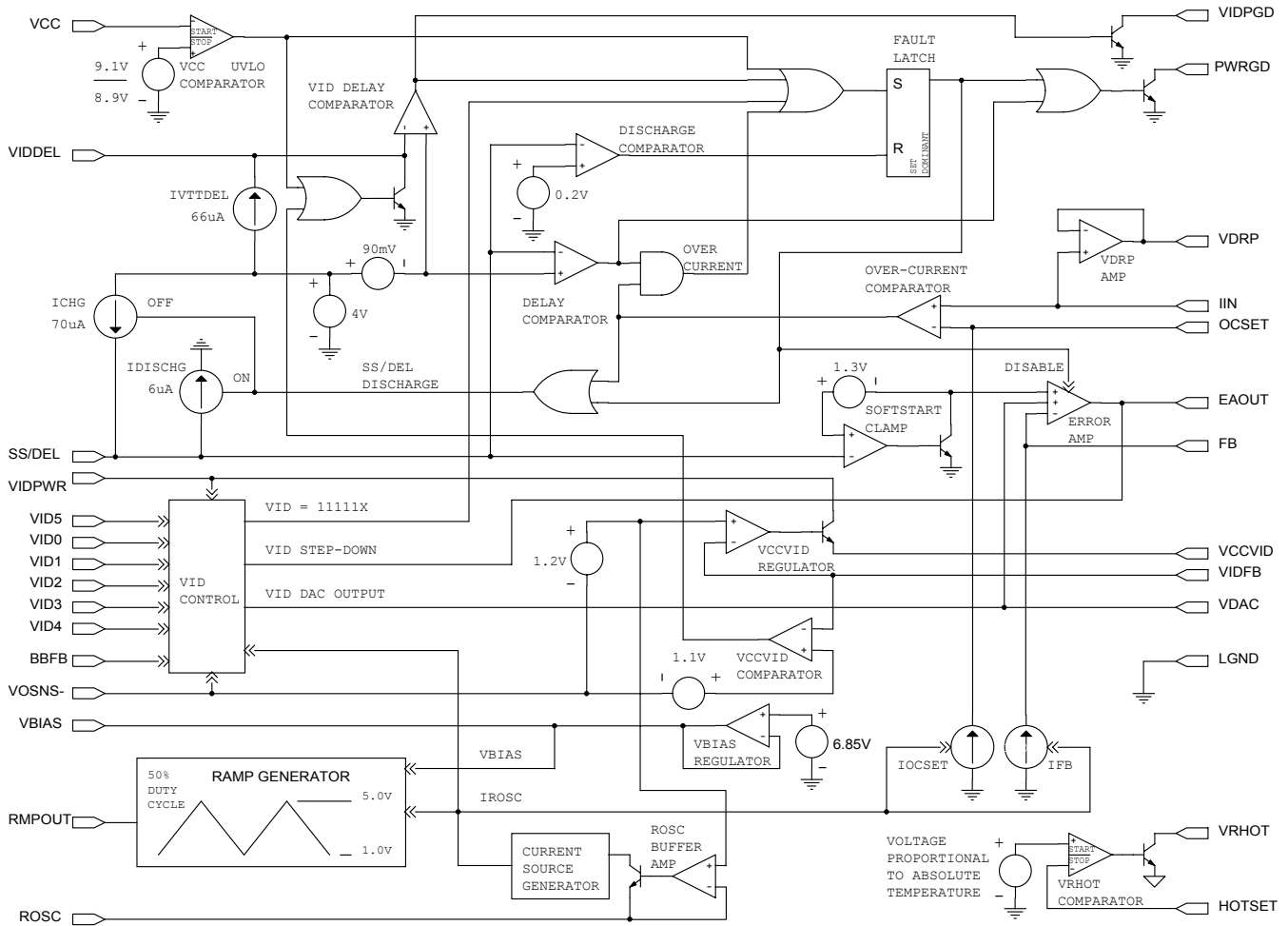

Figure 6. IR3080 Block Diagram

VID Control

A 6-bit VID voltage compatible with VR 10, as shown in Table 1, is available at the VDAC pin. A detailed block diagram of the VID control circuitry can be found in Figure 7. The VID pins are internally pulled up to VIDPWR pin through 700Ω resistors. The VID input comparators, with 0.6V reference, monitor the VID pins and control the 6 bit Digital-to-Analog Converter (DAC) whose output is sent to the VDAC buffer amplifier. The output of the buffer amplifier is the VDAC pin. The VDAC voltage is post-package trimmed to compensate for the input offsets of the Error Amplifier to provide a 0.5% **system set-point** accuracy. The actual VDAC voltage does not determine the system accuracy and has a wider tolerance.

The IR3080 can accept changes in the VID code while operating and vary the DAC voltage accordingly. The sink/source capability of the VDAC buffer amplifier is programmed by the same external resistor that sets the oscillator frequency. The slew rate of the voltage at the VDAC pin can be adjusted by an external capacitor between VDAC pin and the VOSNS- pin. A resistor connected in series with this capacitor is required to compensate the VDAC buffer amplifier. Digital VID transitions result in a smooth analog transition of the VDAC voltage and converter output voltage minimizing inrush currents in the input and output capacitors and overshoot of the output voltage.

It is desirable to prevent negative inductor currents in response to a request for a lower VID code. Negative current transforms the buck converter into a boost converter and transfers energy from the output capacitors back into the input voltage. This energy can cause voltage spikes and damage the silver box or other components unless they are specifically designed to handle it. Furthermore, power is wasted during the transfer of energy from the output back to the input.

The IR3080 includes circuitry that turns off both control and synchronous MOSFETs in response to a lower VID code so that the load current instead of the inductor discharges the output capacitors. A lower VID code is detected by the VID step-down detect comparator which monitors the "fast" output of the DAC (plus 7mV for noise immunity) compared to the "slow" output of the VDAC pin. If a dynamic VID step down is detected, the body brake latch is set and the output of the error amplifier is pulled down to 75% of the DAC voltage by the VID body brake clamp. This triggers the Body Braking™ function, which turns off both high side and low side drivers in the phase ICs.

The converter's output voltage needs to be monitored and compared to the VDAC voltage to determine when to resume normal operation. Unfortunately, the voltage on the FB pin can be pulled down by its compensation network during the sudden decrease in the Error Amplifier's output voltage so an additional pin BBFB is provided. The BBFB pin is connected to the converter output voltage and VDRP pin with resistors of the same value as on the FB pin and therefore provides an un-corrupted representation of converter output voltage. The regulation detect comparator compares the BBFB to the VDAC voltage and resets the body brake latch releasing the error amplifier's output and allowing normal operation to resume. Body Braking™ during a transition to a lower VID code can be disabled by connecting the BBFB pin to ground.

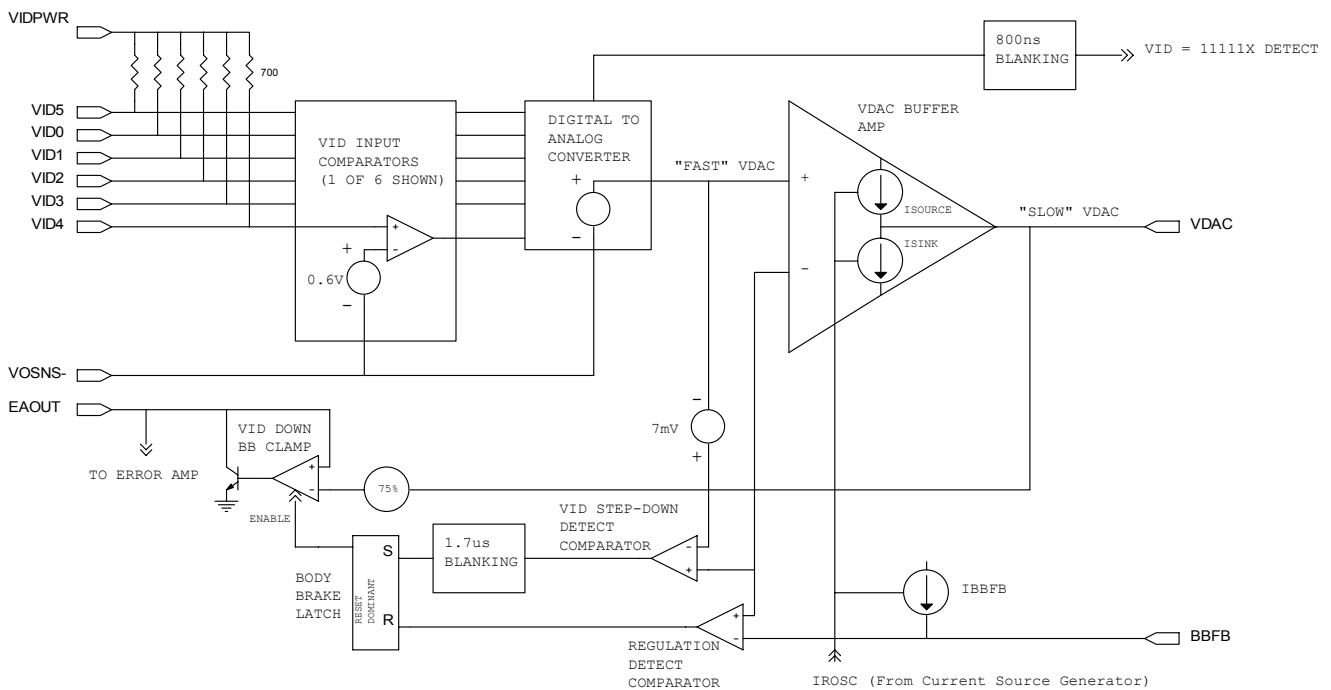

Figure 7. VID Control Block Diagram

Processor Pins (0 = low, 1 = high)						Vout (V)	Processor Pins (0 = low, 1 = high)						Vout (V)
VID4	VID3	VID2	VID1	VID0	VID5		VID4	VID3	VID2	VID1	VID0	VID5	
0	1	0	1	0	0	0.8375	1	1	0	1	0	0	1.2125
0	1	0	0	1	1	0.8500	1	1	0	0	1	1	1.2250
0	1	0	0	1	0	0.8625	1	1	0	0	1	0	1.2375
0	1	0	0	0	1	0.8750	1	1	0	0	0	1	1.2500
0	1	0	0	0	0	0.8875	1	1	0	0	0	0	1.2625
0	0	1	1	1	1	0.9000	1	0	1	1	1	1	1.2750
0	0	1	1	1	0	0.9125	1	0	1	1	1	0	1.2875
0	0	1	1	0	1	0.9250	1	0	1	1	0	1	1.3000
0	0	1	1	0	0	0.9375	1	0	1	1	0	0	1.3125
0	0	1	0	1	1	0.9500	1	0	1	0	1	1	1.3250
0	0	1	0	1	0	0.9625	1	0	1	0	1	0	1.3375
0	0	1	0	0	1	0.9750	1	0	1	0	0	1	1.3500
0	0	1	0	0	0	0.9875	1	0	1	0	0	0	1.3625
0	0	0	1	1	1	1.0000	1	0	0	1	1	1	1.3750
0	0	0	1	1	0	1.0125	1	0	0	1	1	0	1.3875
0	0	0	1	0	1	1.0250	1	0	0	1	0	1	1.4000
0	0	0	1	0	0	1.0375	1	0	0	1	0	0	1.4125
0	0	0	0	1	1	1.0500	1	0	0	0	1	1	1.4250
0	0	0	0	1	0	1.0625	1	0	0	0	1	0	1.4375
0	0	0	0	0	1	1.0750	1	0	0	0	0	1	1.4500
0	0	0	0	0	0	1.0875	1	0	0	0	0	0	1.4625
1	1	1	1	1	1	OFF ⁴	0	1	1	1	1	1	1.4750
1	1	1	1	1	0	OFF ⁴	0	1	1	1	1	0	1.4875
1	1	1	1	0	1	1.1000	0	1	1	1	0	1	1.5000
1	1	1	1	0	0	1.1125	0	1	1	1	0	0	1.5125
1	1	1	1	0	1	1.1250	0	1	1	1	0	1	1.5250
1	1	1	1	0	1	1.1375	0	1	1	1	0	0	1.5375
1	1	1	0	0	1	1.1500	0	1	1	1	0	0	1.5500
1	1	1	0	0	0	1.1625	0	1	1	1	0	0	1.5625
1	1	0	1	1	1	1.1750	0	1	0	1	1	1	1.5750
1	1	0	1	1	0	1.1875	0	1	0	1	1	0	1.5875
1	1	0	1	0	1	1.2000	0	1	0	1	0	1	1.6000

Note: 3. Output disabled (Fault mode)

Table 1 - Voltage Identification (VID)

Adaptive Voltage Positioning

Adaptive voltage positioning is needed to reduce the output voltage deviations during load transients and the power dissipation of the load when it is drawing maximum current. The circuitry related to voltage positioning is shown in Figure 8. Resistor RFB is connected between the Error Amplifier's inverting input pin FB and the converter's output voltage. An internal current source whose value is programmed by the same external resistor that programs the oscillator frequency pumps current into the FB pin. The error amplifier forces the converter's output voltage lower to maintain a balance at its inputs. RFB is selected to program the desired amount of fixed offset voltage below the DAC voltage.

The voltage at the VDRP pin is a buffered version of the share bus and represents the sum of the DAC voltage and the average inductor current of all the phases. The VDRP pin is connected to the FB pin through the resistor RDRP. Since the Error Amplifier will force the loop to maintain FB to be equal to the VDAC reference voltage, an additional current will flow into the FB pin equal to $(VDRP - VDAC) / RDRP$. When the load current increases, the adaptive positioning voltage increases accordingly. More current flows through the feedback resistor RFB, and makes the output voltage lower proportional to the load current. The positioning voltage can be programmed by the resistor RDRP so that the droop impedance produces the desired converter output impedance. The offset and slope of the converter output impedance are referenced to and therefore independent of the VDAC voltage.

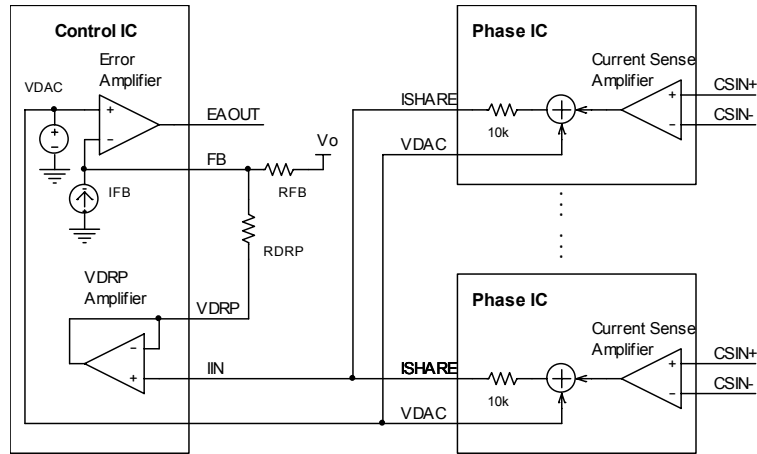

Figure 8. Adaptive voltage positioning

Inductor DCR Temperature Correction

If the thermal compensation of the inductor DCR provided by the temperature dependent gain of the current sense amplifier is not adequate, a negative temperature coefficient (NTC) thermistor can be used for additional correction. The thermistor should be placed close to the inductor and connected in parallel with the feedback resistor, as shown in Figure 9. The resistor in series with the thermistor is used to reduce the nonlinearity of the thermistor. A similar network must be placed on the BBFB pin to ensure proper operation during a transition to a lower VID code with Body Braking™.

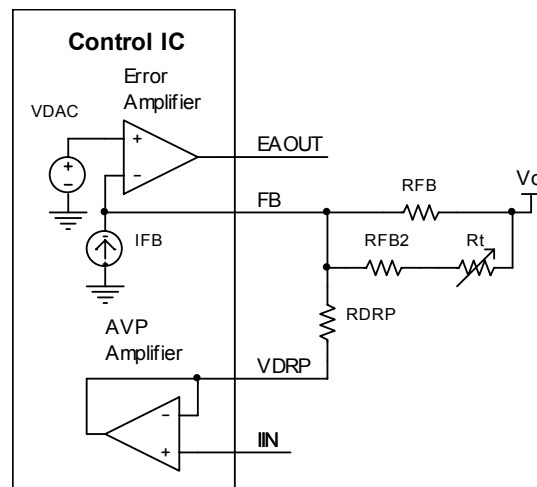

Figure 9. Temperature compensation of inductor DCR

Remote Voltage Sensing

To reduce the effect of impedance in the ground plane, the VOSNS- pin is used for remote sensing and connected directly to the load. The VDAC voltage is referenced to VOSNS- to avoid additional error terms or delay related to a separate differential amplifier. The capacitor connecting the VDAC and VOSNS- pins ensure that high speed transients are fed directly into the error amplifier without delay.

VCC VID Linear Regulator and VID Power Good

The IR3080 integrates a fully protected 1.2V/150mA VCCVID linear regulator with over-current protection. Power for the VCCVID regulator is drawn from the VIDPWR pin which is typically connected to a 3.3V supply. If the linear regulator output voltage is above 1.1V for a time period programmed by a capacitor between VIDDEL and LGND, the VIDPGD pin will send out a VID power good signal and start-up of the converter is allowed. The PWRGD pin is an open-collector output and should be pulled up to a voltage source through a resistor.

An external NPN transistor can be used to enhance the current capability of the linear regulator, as shown in Figure 10. The 5 ohm resistor provides loop compensation and over-current protection.

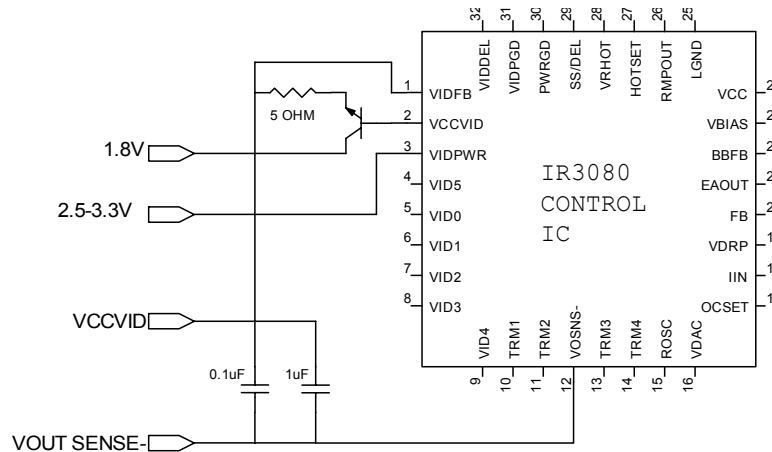

Figure 10. VCC VID linear regulator using external transistor

Soft Start, Over-Current Fault Delay, and Hiccup Mode

The IR3080 has a programmable soft-start function to limit the surge current during the converter start-up. A capacitor connected between the SS/DEL and LGND pins controls soft start as well as over-current protection delay and hiccup mode timing. A charge current of 70uA and discharge current of 6uA control the up slope and down slope of the voltage at the SS/DEL pin respectively

Figure 11 depicts the various operating modes as controlled by the SS/DEL function. If there is no fault, the SS/DEL capacitor pin will begin to be charged. The error amplifier output is clamped low until SS/DEL reaches 1.3V. The error amplifier will then regulate the converter's output voltage to match the SS/DEL voltage less the 1.3V offset until it reaches the level determined by the VID inputs. The SS/DEL voltage continues to increase until it rises above 3.91V and allows the PWRGD signal to be asserted. SS/DEL finally settles at 4V, indicating the end of the soft start.

Under Voltage Lock Out, a VID=11111x, and VCC VID faults immediately set the fault latch causing SS/DEL to begin to discharge. The SS/DEL capacitor will continue to discharge down to 0.2V. If the fault has cleared the fault latch will be reset by the discharge comparator allowing a normal soft start to occur.

A delay is included if an over-current condition occurs after a successful soft start sequence. This is required since over-current conditions can occur as part of normal operation due to load transients or VID transitions. If an over-current fault occurs during normal operation it will initiate the discharge of the capacitor at SS/DEL but will not set the fault latch immediately. If the over-current condition persists long enough for the SS/DEL capacitor to discharge below the 90mV offset of the delay comparator, the Fault latch will be set pulling the error amplifier's output low inhibiting switching in the phase ICs and de-asserting the PWRGD signal. The SS/DEL capacitor will continue to discharge until it reaches 0.2V and the fault latch is reset allowing a normal soft start to occur. If an over-current condition is again encountered during the soft start cycle the fault latch will be set without any delay and hiccup mode will begin. During hiccup mode the charge to discharge current ratio results in a fixed 7.9% hiccup mode duty cycle regardless of at what point the over-current condition occurs. However, the hiccup frequency is determined by the load current and over-current set value.

The over-current delay can be reduced by adding a resistor in series with the SS/DEL capacitor. The delay comparator's offset voltage is reduced by the drop in the resistor caused by the discharge current. The value of the series resistor should be 10KΩ or less to avoid interference with the soft start function.

If SS/DEL pin is pulled below 0.9V, the converter can be disabled.

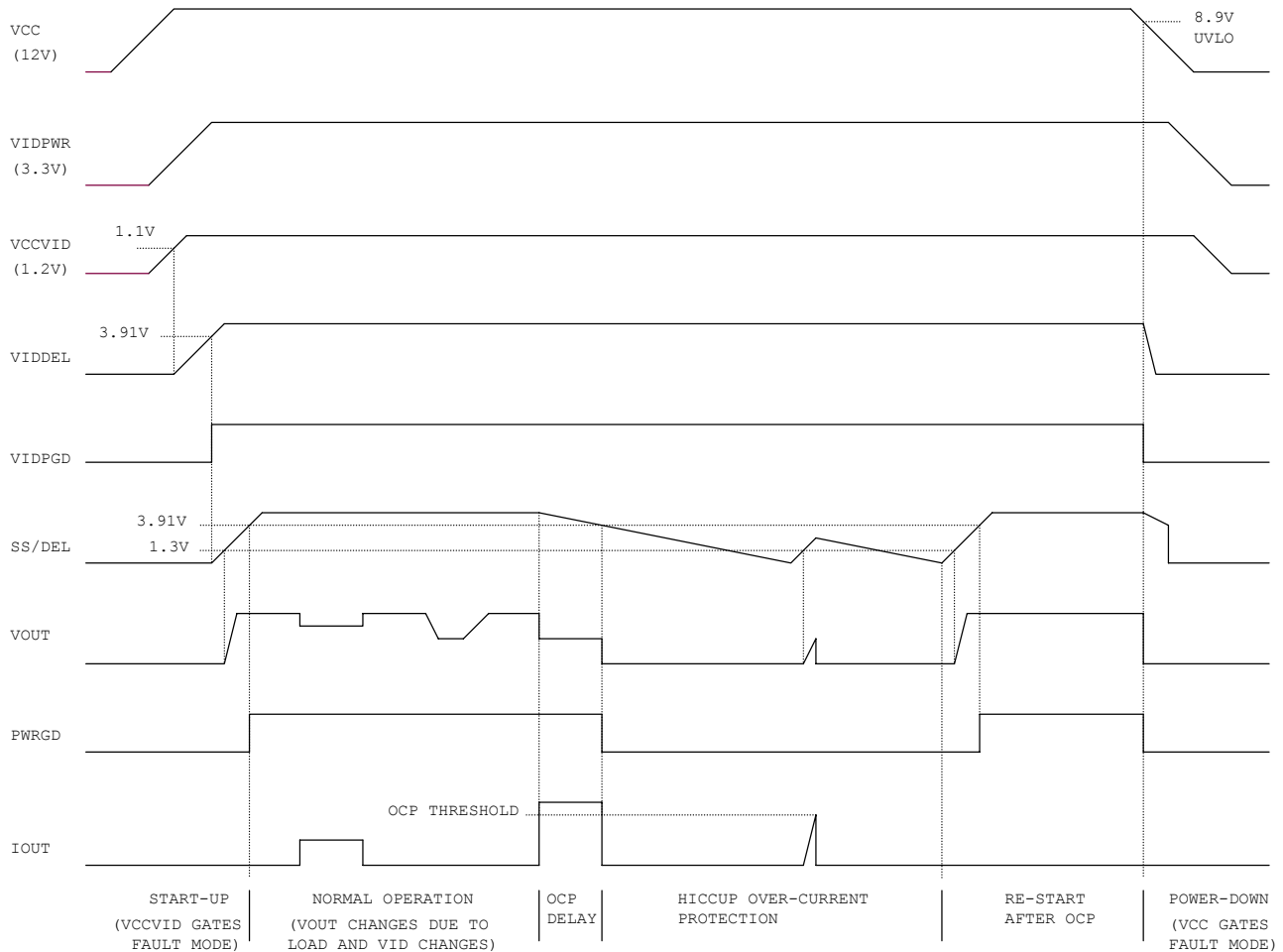

Figure 11. Operating Waveforms

Under Voltage Lockout (UVLO)

The UVLO function monitors the IR3080's VCC supply pin and ensures that IR3080 has a high enough voltage to power the internal circuit. The IR3080's UVLO is set higher than the minimum operating voltage of compatible Phase ICs thus providing UVLO protection for them as well. During power-up the fault latch is reset when VCC exceeds 9.1V and there is no other fault. If the VCC voltage drops below 8.9V the fault latch will be set. For converters using a separate 5V supply for gate driver bias an external UVLO circuit can be added to prevent any operation until adequate voltage is present. A diode connected between the 5V supply and the SS/DEL pin provides a simple 5V UVLO function. UVLO of the VIDPWR input is provided by the VID Power Good function. Adequate voltage must be present at VIDPWR pin to allow VCCVID to reach 1.1V.

Over Current Protection (OCP)

The current limit threshold is set by a resistor connected between the OCSET and VDAC pins. If the IIN pin voltage, which is proportional to the average current plus DAC voltage, exceeds the OCSET voltage, the over-current protection is triggered.

VID = 11111X Fault

VID codes of 111111 and 111110 will set the fault latch and disable the error amplifier. An 800ns delay is provided to prevent a fault condition from occurring during Dynamic VID changes.

Power Good Output

The PWRGD pin is an open-collector output and should be pulled up to a voltage source through a resistor. During soft start, the PWRGD remains low until the output voltage is in regulation and SS/DEL is above 3.91V. The PWRGD pin becomes low if the fault latch is set. A high level at the PWRGD pin indicates that the converter is in operation and has no fault, but does not ensure the output voltage is within the specification. Output voltage regulation within the design limits can logically be assured however, assuming no component failure in the system.

Load Current Indicator Output

The VDRP pin voltage represents the average current of the converter plus the DAC voltage. The load current can be retrieved by a differential amplifier which subtracts the VDAC voltage from the VDRP voltage.

System Reference Voltage (VBIAS)

The IR3081 supplies a 6.8V/5mA precision reference voltage from the VBIAS pin. The oscillator ramp amplitude tracks the VBIAS voltage, which should be used to program the Phase IC trip points to minimize phase delay errors.

Thermal Monitoring (VRHOT)

The IR3080 senses its own die temperature and produces a voltage at the input of the VRHOT comparator that is proportional to temperature. An external resistor divider connected from VBIAS to the HOTSET pin and ground can be used to program the thermal trip point of the VRHOT comparator. The VRHOT pin is an open-collector output and should be pulled up to a voltage source through a resistor. If the thermal trip point is reached the VRHOT output drives low. Pulling HOTSET above approximately 7.5V will disable the oscillator (used during factory testing).

APPLICATION INFORMATIONS

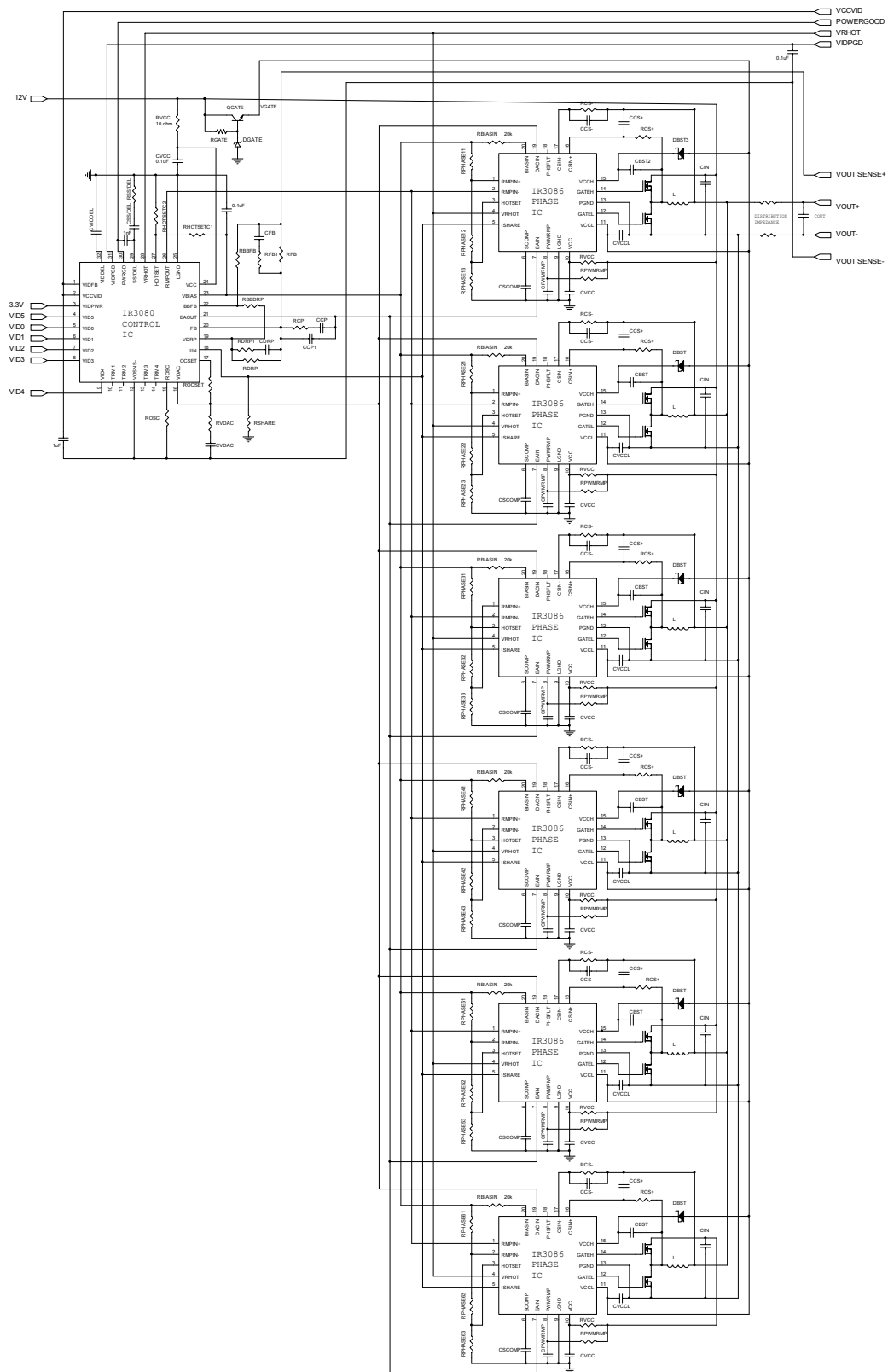

Figure 12. IR3080/IR3086 Six Phase VRD 10 Converter

DESIGN PROCEDURES - IR3080 AND IR3086 CHIPSET

IR3080 EXTERNAL COMPONENTS

Oscillator Resistor R_{osc}

The oscillator of IR3080 generates a triangle waveform to synchronize the phase ICs, and the switching frequency of the each phase converter equals the oscillator frequency, which is set by the external resistor R_{osc} according to the curve in Figure 13.

VID Delay Capacitor C_{VIDDEL}

After the VID voltage of the integrated linear regulator is above 1.1V, there is a time delay before the soft start of the converter is initiated. The VID delay time t_{VID} can be programmed by an external capacitor between VIDDEL pin and LGND, and the capacitance is determined by (1).

$$C_{VIDDEL} = \frac{66 * 10^{-6} * t_{VID}}{3.91} \quad (1)$$

Soft Start Capacitor $C_{SS/DEL}$ and Resistor $R_{SS/DEL}$

Because the capacitor $C_{SS/DEL}$ programs four different time parameters, i.e. soft start delay time, soft start time, over-current latch delay time, and power good delay time, they should be considered together while choosing $C_{SS/DEL}$.

The SS/DEL pin voltage controls the slew rate of the converter output voltage, as shown in Figure 11. After the VIDDEL pin voltage rises above 3.91V, there is a soft-start delay time t_{SSDEL} , after which the error amplifier output is released to allow the soft start. The soft start time t_{SS} represents the time during which converter voltage rises from zero to V_O . t_{SS} can be programmed by an external capacitor, which is determined by Equation (2).

$$C_{SS/DEL} = \frac{I_{CHG} * t_{SS}}{V_O} = \frac{70 * 10^{-6} * t_{SS}}{V_O} \quad (2)$$

Once $C_{SS/DEL}$ is chosen, the soft start delay time t_{SSDEL} , the over-current fault latch delay time t_{OCDEL} , and the delay time t_{VccPG} from output voltage (V_O) in regulation to Power Good are fixed and shown in Equations (3), (4) and (5) respectively.

$$t_{SSDEL} = \frac{C_{SS/DEL} * 1.3}{I_{CHG}} = \frac{C_{SS/DEL} * 1.3}{70 * 10^{-6}} \quad (3)$$

$$t_{OCDEL} = \frac{C_{SS/DEL} * 0.09}{I_{DISCHG}} = \frac{C_{SS/DEL} * 0.09}{6 * 10^{-6}} \quad (4)$$

$$t_{VccPG} = \frac{C_{SS/DEL} * (3.91 - V_O - 1.3)}{I_{CHG}} = \frac{C_{SS/DEL} * (3.91 - V_O - 1.3)}{70 * 10^{-6}} \quad (5)$$

If faster over-current protection is required, a resistor in series with the soft start capacitor $C_{SS/DEL}$ can be used to reduce the over-current fault latch delay time t_{OCDEL} , and the resistor $R_{SS/DEL}$ is determined by Equation (6). Equation (2) for soft start capacitor $C_{SS/DEL}$ and Equation (5) for power good delay time t_{VccPG} are unchanged, while the equation for soft start delay time $t_{SS/DEL}$ (Equation 3) is changed to Equation (7). Considering the worst case values of charge and discharge current, $R_{SS/DEL}$ should not be greater than 10 k Ω .

$$R_{SS/DEL} = \frac{0.09 - \frac{t_{OCDEL} * I_{DISCHG}}{C_{SS/DEL}}}{I_{DISCHG}} - \frac{0.09 - \frac{t_{OCDEL} * 6 * 10^{-6}}{C_{SS/DEL}}}{6 * 10^{-6}} \quad (6)$$

$$t_{SSDEL} = \frac{C_{SS/DEL} * (1.3 - R_{SS/DEL} * I_{CHG})}{I_{CHG}} = \frac{C_{SS/DEL} * (1.3 - R_{SS/DEL} * 70 * 10^{-6})}{70 * 10^{-6}} \quad (7)$$

VDAC Slew Rate Programming Capacitor C_{VDAC} and Resistor R_{VDAC}

The slew rate of VDAC down-slope SR_{DOWN} can be programmed by the external capacitor C_{VDAC} as defined in Equation (8), where I_{SINK} is the sink current of VDAC pin as shown in Figure 15. The resistor R_{VDAC} is used to compensate VDAC circuit and is determined by Equation (9). The slew rate of VDAC up-slope SR_{UP} is proportional to that of VDAC down-slope and is given by Equation (10), where I_{SOURCE} is the source current of VDAC pin as shown in Figure 15.

$$C_{VDAC} = \frac{I_{SINK}}{SR_{DOWN}} \quad (8)$$

$$R_{VDAC} = 0.5 + \frac{3.2 * 10^{-15}}{C_{VDAC}^2} \quad (9)$$

$$SR_{UP} = \frac{I_{SOURCE}}{C_{VDAC}} \quad (10)$$

Over Current Setting Resistor R_{OCSET}

The inductor DC resistance is utilized to sense the inductor current. The copper wire of inductor has a constant temperature coefficient of 3850 ppm/°C, and therefore the maximum inductor DCR can be calculated from Equation (11), where R_{L_MAX} and R_{L_ROOM} are the inductor DCR at maximum temperature T_{L_MAX} and room temperature T_{ROOM} respectively.

$$R_{L_MAX} = R_{L_ROOM} * [1 + 3850 * 10^{-6} * (T_{L_MAX} - T_{ROOM})] \quad (11)$$

The current sense amplifier gain of IR3086 decreases with temperature at the rate of 1470 ppm/°C, which compensates part of the inductor DCR increase. The phase IC die temperature is only a couple of degrees Celsius higher than the PCB temperature due to the low thermal impedance of MLPQ package. The minimum current sense amplifier gain at the maximum phase IC temperature T_{IC_MAX} is calculated from Equation (12).

$$G_{CS_MIN} = G_{CS_ROOM} * [1 - 1470 * 10^{-6} * (T_{IC_MAX} - T_{ROOM})] \quad (12)$$

The total input offset voltage (V_{CS_TOFST}) of current sense amplifier in phase ICs is the sum of input offset (V_{CS_OFST}) of the amplifier itself and that created by the amplifier input bias currents flowing through the current sense resistors R_{CS+} and R_{CS-} .

$$V_{CS_TOFST} = V_{CS_OFST} + I_{CSIN+} * R_{CS+} - I_{CSIN-} * R_{CS-} \quad (13)$$

The over current limit is set by the external resistor R_{OCSET} as defined in Equation (14), where I_{LIMIT} is the required over current limit. I_{OCSET} , the bias current of OCSET pin, changes with switching frequency setting resistor R_{OSC} and is determined by the curve in Figure 14. K_P is the ratio of inductor peak current over average current in each phase and is calculated from Equation (15).

$$R_{OCSET} = \left[\frac{I_{LIMIT}}{n} * R_{L_MAX} * (1 + K_P) + V_{CS_TOFST} \right] G_{CS_MIN} / I_{OCSET} \quad (14)$$

$$K_P = \frac{(V_I - V_O) * V_O / (L * V_I * f_{SW} * 2)}{I_O / n} \quad (15)$$

No Load Output Voltage Setting Resistor R_{FB} and Adaptive Voltage Positioning Resistor R_{DRP}

A resistor between FB pin and the converter output is used to create output voltage offset V_{O_NLOFST} , which is the difference between V_{DAC} voltage and output voltage at no load condition. Adaptive voltage positioning further lowers the converter voltage by $R_O * I_O$, where R_O is the required output impedance of the converter.

R_{FB} is not only determined by I_{FB} , the current flowing out of FB pin as shown in Figure 14, but also affected by the adaptive voltage positioning resistor R_{DRP} and total input offset voltage of current sense amplifiers. R_{FB} and R_{DRP} are determined by (16) and (17) respectively,

$$R_{FB} = \frac{R_{L_MAX} * V_{O_NLOFST} - V_{CS_TOFST} * n * R_O}{I_{FB} * R_{L_MAX}} \quad (16)$$

$$R_{DRP} = \frac{R_{FB} * R_{L_MAX} * G_{CS_MIN}}{n * R_O} \quad (17)$$

Control IC Over Temperature Setting Resistors $R_{HOTSETC1}$ and $R_{HOTSETC2}$

The threshold voltage of V_{RHOT} comparator is proportional to the die temperature T_J (°C) of control IC IR3080, as shown in Equation (18). Determine the relationship between the die temperature of IR3080 and the temperature of the power converter according to the power loss, PCB layout and airflow, etc. Then calculate the V_{RHOT} threshold voltage corresponding to the temperature.

$$V_{VRHOT} = 4.73 * 10^{-3} * T_J + 1.241 \quad (18)$$

Use V_{BIAS} as the reference voltage. If $R_{HOTSETC1}$ is pre selected, $R_{HOTSETC2}$ can be calculated according to Equation (19).

$$R_{HOTSETC2} = R_{HOTSETC1} \frac{V_{VRHOT}}{V_{VBIAS} + V_{VRHOT}} \quad (19)$$

Body Braking™ Related Resistors R_{BBFB} and R_{BBDRP}

The body braking™ during Dynamic VID can be disabled by connecting $BBFB$ pin to ground. If the feature is enabled, Resistors R_{BBFB} and R_{BBDRP} are needed to restore the feedback voltage of the error amplifier after Dynamic VID step down. Usually R_{BBFB} and R_{BBDRP} are chosen to match R_{FB} and R_{DRP} respectively.

IR3086 EXTERNAL COMPONENTS

PWM Ramp Resistor R_{PWMRMP} and Capacitor C_{PWMRMP}

PWM ramp is generated by connecting the resistor R_{PWMRMP} between a voltage source and $PWMRMP$ pin as well as the capacitor C_{PWMRMP} between $PWMRMP$ and $LGND$. Choose the desired PWM ramp magnitude V_{PWMRMP} and the capacitor C_{PWMRMP} in the range of 100pF and 470pF, and then calculate the resistor R_{PWMRMP} from Equation (20). To achieve feed-forward voltage mode control, the resistor R_{RAMP} should be connected to the input of the converter.

$$R_{PWMRMP} = \frac{V_O}{V_{IN} * f_{SW} * C_{PWMRMP} * [\ln(V_{IN} - V_{DAC}) - \ln(V_{IN} - V_{DAC} - V_{PWMRMP})]} \quad (20)$$

Inductor Current Sensing Capacitor C_{CS+} and Resistors R_{CS+} and R_{CS-}

The DC resistance of the inductor is utilized to sense the inductor current. Usually the resistor R_{CS+} and capacitor C_{CS+} in parallel with the inductor are chosen to match the time constant of the inductor, and therefore the voltage across the capacitor C_{CS+} represents the inductor current. If the two time constants are not the same, the AC component of the capacitor voltage is different from that of the real inductor current. The time constant mismatch does not affect the average current sharing among the multiple phases, but affect the current signal $ISHARE$ as well as the output voltage during the load current transient if adaptive voltage positioning is adopted.

Measure the inductance L and the inductor DC resistance R_L . Pre-select the capacitor C_{CS+} and calculate R_{CS+} as follows.

$$R_{CS+} = \frac{L/R_L}{C_{CS+}} \quad (21)$$

The bias current flowing out of the non-inverting input of the current sense amplifier creates a voltage drop across R_{CS+} , which is equivalent to an input offset voltage of the current sense amplifier. The offset affects the accuracy of converter current signal $ISHARE$ as well as the accuracy of the converter output voltage if adaptive voltage positioning is adopted. To reduce the offset voltage, a resistor R_{CS-} should be added between the amplifier inverting input and the converter output. The resistor R_{CS-} is determined by the ratio of the bias current from the non-inverting input and the bias current from the inverting input.

$$R_{CS-} = \frac{I_{CSIN+}}{I_{CSIN-}} * R_{CS+} \quad (22)$$

If R_{CS-} is not used, R_{CS+} should be chosen so that the offset voltage is small enough. Usually R_{CS+} should be less than 2 k Ω and therefore a larger C_{CS+} value is needed.

Over Temperature Setting Resistors $R_{HOTSET1}$ and $R_{HOTSET2}$

The threshold voltage of VR_{HOT} comparator is proportional to the die temperature T_J ($^{\circ}C$) of phase IC. Determine the relationship between the die temperature of phase IC and the temperature of the power converter according to the power loss, PCB layout and airflow etc, and then calculate $HOTSET$ threshold voltage corresponding to the allowed maximum temperature from Equation (23).

$$V_{HOTSET} = 4.73 * 10^{-3} * T_J + 1.241 \quad (23)$$

There are two ways to set the over temperature threshold, central setting and local setting. In the central setting, only one resistor divider is used, and the setting voltage is connected to $HOTSET$ pins of all the phase ICs. To reduce the influence of noise on the accuracy of over temperature setting, a 0.1 μF capacitor should be placed next to $HOTSET$ pin of each phase IC. In the local setting, a resistor divider per phase is needed, and the setting voltage is connected to $HOTSET$ pin of each phase. The 0.1 μF decoupling capacitor is not necessary. Use V_{BIAS} as the reference voltage. If $R_{HOTSET1}$ is pre-selected, $R_{HOTSET2}$ can be calculated as follows.

$$R_{HOTSET2} = \frac{R_{HOTSET1} * V_{HOTSET}}{V_{BIAS} - V_{HOTSET}} \quad (24)$$

Phase Delay Timing Resistors R_{PHASE1} and R_{PHASE2}

The phase delay of the interleaved multiphase converter is programmed by the resistor divider connected at $RMPIN+$ or $RMPIN-$ depending on which slope of the oscillator ramp is used for the phase delay programming of phase IC, as shown in Figure 3.

If the upslope is used, $RMPIN+$ pin of the phase IC should be connected to $RMPOUT$ pin of the control IC and $RMPIN-$ pin should be connected to the resistor divider. When $RMPOUT$ voltage is above the trip voltage at $RMPIN-$ pin, the PWM latch is set. $GATEL$ becomes low, and $GATEH$ becomes high after the non-overlap time.

If down slope is used, $RMPIN-$ pin of the phase IC should be connected to $RMPOUT$ pin of the control IC and $RMPIN+$ pin should be connected to the resistor divider. When $RMPOUT$ voltage is below the trip voltage at $RMPIN-$ pin, the PWM latch is set. $GATEL$ becomes low, and $GATEH$ becomes high after the non-overlap time.

Use V_{BIAS} voltage as the reference for the resistor divider since the oscillator ramp magnitude from control IC tracks V_{BIAS} voltage. Try to avoid both edges of the oscillator ramp for better noise immunity. Determine the ratio of the programming resistors corresponding to the desired switching frequencies and phase numbers. If the resistor $R_{PHASEx1}$ is pre-selected, the resistor $R_{PHASEx2}$ is determined as:

$$R_{PHASEx2} = \frac{R_{APHASEx} * R_{PHASEx1}}{1 - R_{APHASEx}} \quad (25)$$

Combined Over Temperature and Phase Delay Setting Resistors R_{PHASE1} , R_{PHASE2} and R_{PHASE3}

The over temperature setting resistor divider can be combined with the phase delay resistor divider to save one resistor per phase.

Calculate the HOTSET threshold voltage V_{HOTSET} corresponding to the allowed maximum temperature from Equation (23). If the over temperature setting voltage is lower than the phase delay setting voltage, $V_{BIAS} * R_{PHASEx}$, connect RMPIN+ or RMPIN- pin between $R_{PHASEx1}$ and $R_{PHASEx2}$, and connect HOTSET pin between $R_{PHASEx2}$ and $R_{PHASEx3}$. Pre-select $R_{PHASEx1}$,

$$R_{PHASEx2} = \frac{(R_{PHASEx} * V_{BIAS} - V_{HOTSET}) * R_{PHASEx1}}{V_{BIAS} * (1 - R_{PHASEx})} \quad (26)$$

$$R_{PHASEx3} = \frac{V_{HOTSET} * R_{PHASEx1}}{V_{BIAS} * (1 - R_{PHASEx})} \quad (27)$$

If the over temperature setting voltage is higher than the phase delay setting voltage, $V_{BIAS} * R_{PHASEx}$, connect HOTSET pin between $R_{PHASEx1}$ and $R_{PHASEx2}$ and connect RMPIN+ or RMPIN- between $R_{PHASEx2}$ and $R_{PHASEx3}$ respectively. Pre-select $R_{PHASEx1}$,

$$R_{PHASEx2} = \frac{(V_{HOTSET} - R_{PHASEx} * V_{BIAS}) * R_{PHASEx1}}{V_{BIAS} - V_{HOTSET}} \quad (28)$$

$$R_{PHASEx3} = \frac{R_{PHASEx} * V_{BIAS} * R_{PHASEx1}}{V_{BIAS} - V_{HOTSET}} \quad (29)$$

Bootstrap Capacitor C_{BST}

Depending on the duty cycle and gate drive current of the phase IC, a 0.1uF to 1uF capacitor is needed for the bootstrap circuit.

Decoupling Capacitors for Phase IC

0.1uF-1uF decoupling capacitors are required at VCC and VCCL pins of phase ICs.

VOLTAGE LOOP COMPENSATION

The adaptive voltage positioning (AVP) is usually adopted in the computer applications to improve the transient response and reduce the power loss at heavy load. Like current mode control, the adaptive voltage positioning loop introduces extra zero to the voltage loop and splits the double poles of the power stage, which make the voltage loop compensation much easier.

Resistors R_{FB} and R_{DRP} are chosen according to Equations (16) and (17), and the selection of compensation types depends on the output capacitors used in the converter. For the applications using Electrolytic, Polymer or AL-Polymer capacitors and running at lower frequency, type II compensation shown in Figure 17(a) is usually enough. While for the applications using only ceramic capacitors and running at higher frequency, type III compensation shown in Figure 17(b) is preferred.

For applications where AVP is not required, the compensation is the same as for the regular voltage mode control. For converter using Polymer, AL-Polymer, and ceramic capacitors, which have much higher ESR zero frequency, type III compensation is required as shown in Figure 17(b) with R_{DRP} and C_{DRP} removed.

Type II Compensation for AVP Applications

Determine the compensation at no load, the worst case condition. Choose the crossover frequency f_c between 1/10 and 1/5 of the switching frequency per phase. Assume the time constant of the resistor and capacitor across the output inductors matches that of the inductor, and determine R_{CP} and C_{CP} from Equations (30) and (31), where L_E and C_E are the equivalent inductance of output inductors and the equivalent capacitance of output capacitors respectively.

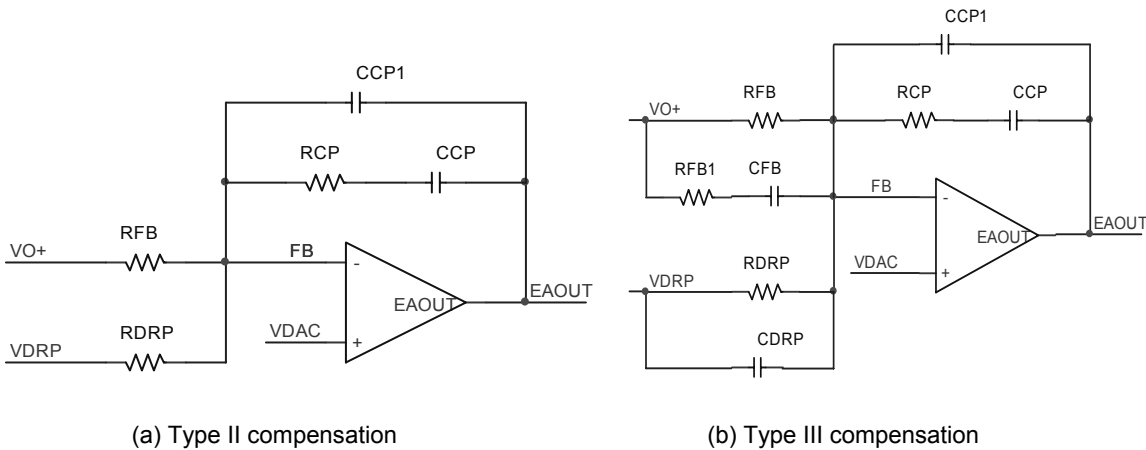

Figure 17. Voltage loop compensation network

$$R_{CP} = \frac{(2\pi * f_C)^2 * L_E * C_E * R_{FB} * V_{PWRMP}}{V_O * \sqrt{1 + (2\pi * f_C * C * R_C)^2}} \quad (30)$$

$$C_{CP} = \frac{10 * \sqrt{L_E * C_E}}{R_{CP}} \quad (31)$$

CCP1 is optional and may be needed in some applications to reduce the jitter caused by the high frequency noise. A ceramic capacitor between 10pF and 220pF is usually enough.

Type III Compensation for AVP Applications

Determine the compensation at no load, the worst case condition. Assume the time constant of the resistor and capacitor across the output inductors matches that of the inductor, the crossover frequency and phase margin of the voltage loop can be estimated by Equations (32) and (33), where R_{LE} is the equivalent resistance of inductor DCR.

$$f_{C1} = \frac{R_{DRP}}{2\pi * C_E * G_{CS} * R_{FB} * R_{LE}} \quad (32)$$

$$\theta_{C1} = 90 - A \tan(0.5) * \frac{180}{\pi} \quad (33)$$

Choose the desired crossover frequency f_c around f_{c1} estimated by Equation (32) or choose f_c between 1/10 and 1/5 of the switching frequency per phase, and select the components to ensure the slope of close loop gain is -20dB/Dec around the crossover frequency. Choose resistor R_{FB1} according to Equation (34), and determine C_{FB} and R_{DRP} from Equations (35) and (36).

$$R_{FB1} = \frac{1}{2} R_{FB} \quad \text{to} \quad R_{FB1} = \frac{2}{3} R_{FB} \quad (34)$$

$$C_{FB} = \frac{1}{4\pi * f_C * R_{FB1}} \quad (35)$$

$$C_{DRP} = \frac{(R_{FB} + R_{FB1}) * C_{FB}}{R_{DRP}} \quad (36)$$

R_{CP} and CCP have limited effect on the crossover frequency, and are used only to fine tune the crossover frequency and transient load response. Determine R_{CP} and CCP from Equations (37) and (38).

$$R_{CP} = \frac{(2\pi * f_C)^2 * L_E * C_E * R_{FB} * V_{PWMRMP}}{V_O} \quad (37)$$

$$C_{CP} = \frac{10 * \sqrt{L_E * C_E}}{R_{CP}} \quad (38)$$

CCP1 is optional and may be needed in some applications to reduce the jitter caused by the high frequency noise. A ceramic capacitor between 10pF and 220pF is usually enough.

Type III Compensation for Non-AVP Applications

Resistor RFB is chosen according to Equations (16), and resistor RDRP and capacitor CDRP are not needed. Choose the crossover frequency fc between 1/10 and 1/5 of the switching frequency per phase and select the desired phase margin θ_c . Calculate K factor from Equation (39), and determine the component values based on Equations (40) to (44),

$$K = \tan\left[\frac{\pi}{4} * \left(\frac{\theta_C}{180} + 1.5\right)\right] \quad (39)$$

$$R_{CP} = R_{FB} * \frac{(2\pi * \sqrt{L_E * C_E} * f_C)^2 * V_{PWMRMP}}{V_O * K} \quad (40)$$

$$C_{CP} = \frac{K}{2\pi * f_C * R_{CP}} \quad (41)$$

$$C_{CP1} = \frac{1}{2\pi * f_C * K * R_{CP}} \quad (42)$$

$$C_{FB} = \frac{K}{2\pi * f_C * R_{FB}} \quad (43)$$

$$R_{FB1} = \frac{1}{2\pi * f_C * K * C_{FB}} \quad (44)$$

CURRENT SHARE LOOP COMPENSATION

The crossover frequency of the current share loop should be at least one decade lower than that of the voltage loop in order to eliminate the interaction between the two loops. A capacitor from SCOMP to ground is usually enough for the share loop compensation. Choose the crossover frequency of current share loop (fci) based on the crossover frequency of voltage loop (fc), and determine the CSCOMP,

$$C_{SCOMP} = \frac{0.65 * R_{PWMRMP} * V_I * I_O * G_{CS_ROOM} * R_{LE} * [1 + 2\pi * f_{CI} * C_E * (V_O / I_O)] * F_{MI}}{V_O * 2\pi * f_{CI} * 1.05 * 10^6} \quad (45)$$

Where FMI is the PWM gain in the current share loop,

$$F_{MI} = \frac{R_{PWMRMP} * C_{PWMRMP} * f_{SW} * V_{PWMRMP}}{(V_I - V_{PWMRMP} - V_{DAC}) * (V_I - V_{DAC})} \quad (46)$$

DESIGN EXAMPLE 1 - VRD 10 CONVERTER

SPECIFICATIONS

Input Voltage: $V_I=12\text{ V}$
 DAC Voltage: $V_{DAC}=1.35\text{ V}$
 No Load Output Voltage Offset: $V_{O_NLOFST}=20\text{ mV}$
 Output Current: $I_O=105\text{ ADC}$
 Maximum Output Current: $I_{OMAX}=120\text{ ADC}$
 Output Impedance: $R_O=0.91\text{ m}\Omega$
 VCC Ready to VCC Power Good Delay: $t_{VCCPG}=0\text{-}10\text{ mS}$
 VID Delay Time: $t_{VID}=2.5\text{ mS}$
 Soft Start Time: $t_{SS}=2\text{ mS}$
 Over Current Delay: $t_{OCDEL}=0.5\text{ mS}$
 Dynamic VID Down-Slope Slew Rate: $SR_{DOWN}=2.5\text{ mV/uS}$
 Over Temperature Threshold: $T_{PCB}=115\text{ }^\circ\text{C}$

POWER STAGE

Phase Number: $n=6$
 Switching Frequency: $f_{sw}=400\text{ kHz}$
 Output Inductors: $L=220\text{ nH}$, $R_L=0.47\text{ m}\Omega$
 Output Capacitors: AL-Polymer, $C=560\text{ uF}$, $R_c=7\text{ m}\Omega$, Number $C_n=10$

IR3080 EXTERNAL COMPONENTS

Oscillator Resistor R_{osc}

Once the switching frequency is chosen, R_{osc} can be determined from the curve in Figure 13. For switching frequency of 400kHz per phase, choose $R_{osc}=30.1\text{ k}\Omega$

VID Delay Capacitor C_{VIDDEL}

Given VID delay time $t_{VID}=2.5\text{ mS}$, the capacitor can is,

$$C_{VIDDEL} = \frac{66 * 10^{-6} * t_{VID}}{3.91} = \frac{66 * 10^{-6} * 2.5 * 10^{-3}}{3.91} = 42\text{ nF}, \text{ choose } 47\text{ nF}$$

Soft Start Capacitor $C_{SS/DEL}$ and Resistor $R_{SS/DEL}$

Because faster over-current protection is required, the soft start capacitor $C_{SS/DEL}$ in series with the resistor $R_{SS/DEL}$ is used. Calculate the soft start capacitor from the required soft start time.

$$C_{SS/DEL} = \frac{I_{CHG} * t_{SS}}{V_O} = \frac{70 * 10^{-6} * 2 * 10^{-3}}{1.35 - 20 * 10^{-3}} = 0.1\text{ uF}$$

Calculate the soft start resistor from the required over current delay time t_{OCDEL} ,

$$R_{SS/DEL} = \frac{0.09 - \frac{t_{OCDEL} * I_{DISCHG}}{C_{SS/DEL}}}{I_{DISCHG}} = \frac{0.09 - \frac{0.5 * 10^{-3} * 6 * 10^{-6}}{0.1 * 10^{-6}}}{6 * 10^{-6}} = 10\text{ k}\Omega$$

The soft start delay time is

$$t_{SSDEL} = \frac{C_{SS/DEL} * (1.3 - R_{SS/DEL} * I_{CHG})}{I_{CHG}} = \frac{0.1 * 10^{-6} * (1.3 - 10 * 10^3 * 70 * 10^{-6})}{70 * 10^{-6}} = 0.86\text{ mS}$$

The power good delay time is

$$t_{V_{CC}PG} = \frac{C_{SS/DEL} * (3.91 - V_O - 1.3)}{I_{CHG}} = \frac{0.1 * 10^{-6} * (3.91 - 1.33 - 1.3)}{70 * 10^{-6}} = 1.8ms$$

VDAC Slew Rate Programming Capacitor C_{VDAC} and Resistor R_{VDAC}

From Figure 15, the sink current of VDAC pin corresponding to 400kHz (Rosc=30.1kΩ) is 76uA. Calculate the VDAC down-slope slew-rate programming capacitor from the required down-slope slew rate.

$$C_{VDAC} = \frac{I_{SINK}}{SR_{DOWN}} = \frac{76 * 10^{-6}}{2.5 * 10^{-3} / 10^{-6}} = 30.4nF, \text{ Choose } C_{VDAC}=33nF$$

Calculate the programming resistor.

$$R_{VDAC} = 0.5 + \frac{3.2 * 10^{-15}}{C_{VDAC}^2} = 0.5 + \frac{3.2 * 10^{-15}}{(33 * 10^{-9})^2} = 3.5\Omega$$

From Figure 15, the source current of VDAC pin is 110uA. The VDAC up-slope slew rate is

$$SR_{UP} = \frac{I_{SOURCE}}{C_{VDAC}} = \frac{110 * 10^{-6}}{33 * 10^{-9}} = 3.3mV / \mu S$$

Over Current Setting Resistor R_{OCSET}

The room temperature is 25°C and the target PCB temperature is 100 °C. The phase IC die temperature is about 1 °C higher than that of phase IC, and the inductor temperature is close to PCB temperature.

Calculate Inductor DC resistance at 100 °C,

$$R_{L_MAX} = R_{L_ROOM} * [1 + 3850 * 10^{-6} * (T_{L_MAX} - T_{ROOM})] = 0.47 * 10^{-3} * [1 + 3850 * 10^{-6} * (100 - 25)] = 0.61m\Omega$$

The current sense amplifier gain is 34 at 25°C, and its gain at 101°C is calculated as,

$$G_{CS_MIN} = G_{CS_ROOM} * [1 - 1470 * 10^{-6} * (T_{IC_MAX} - T_{ROOM})] = 34 * [1 - 1470 * 10^{-6} * (101 - 25)] = 30.2$$

Set the over current limit at 135A. From Figure 14, the bias current of OCSET pin (IOCSET) is 41uA with Rosc=30.1kΩ. The total current sense amplifier input offset voltage is 0.55mV, which includes the offset created by the current sense amplifier input resistor mismatch.

Calculate constant KP, the ratio of inductor peak current over average current in each phase,

$$K_P = \frac{(V_I - V_O) * V_O / (L * V_I * f_{SW} * 2)}{I_{LIMIT} / n} = \frac{(12 - 1.33) * 1.33 / (220 * 10^{-9} * 12 * 400 * 10^3 * 2)}{135 / 6} = 0.3$$

$$R_{OCSET} = \left[\frac{I_{LIMIT}}{n} * R_{L_MAX} * (1 + K_P) + V_{CS_TOFST} \right] * G_{CS_MIN} / I_{OCSET}$$

$$= \left(\frac{135}{6} * 0.61 * 10^{-3} * 1.3 + 0.55 * 10^{-3} \right) * 30.2 / (41 * 10^{-6}) = 13.3k\Omega$$

No Load Output Voltage Setting Resistor R_{FB} and Adaptive Voltage Positioning Resistor R_{DRP}

From Figure 14, the bias current of FB pin is 41uA with Rosc=30.1kΩ.

$$R_{FB} = \frac{R_{L_MAX} * V_{O_NLOFST} - V_{CS_TOFST} * n * R_O}{I_{FB} * R_{L_MAX}} = \frac{0.61 * 10^{-3} * 20 * 10^{-3} - 0.55 * 10^{-3} * 6 * 0.91 * 10^{-3}}{41 * 10^{-6} * 0.61 * 10^{-3}} = 365\Omega$$

$$R_{DRP} = \frac{R_{FB} * R_{L_MAX} * G_{CS_MIN}}{n * R_O} = \frac{365 * 0.61 * 10^{-3} * 30.2}{6 * 0.91 * 10^{-3}} = 1.21k\Omega$$

Control IC Over Temperature Setting Resistors *RHOTSET1* and *RHOTSET2*

Set the temperature threshold at 115 °C, which corresponds to the IC die temperature of 116 °C. Calculate the HOTSET threshold voltage corresponding to the temperature thresholds.

$$V_{HOTSET} = 4.73 * 10^{-3} * T_J + 1.241 = 4.73 * 10^{-3} * 116 + 1.241 = 1.79V, \text{ Choose } RHOTSET1=20.0k\Omega,$$

$$R_{HOTSET2} = \frac{R_{HOTSET1} * V_{HOTSET}}{V_{BIAS} - V_{HOTSET}} = \frac{20 * 10^3 * 1.79}{6.8 - 1.79} = 7.15k\Omega$$

Body Braking Related Resistors *RBBFB* and *RBBDRP*

N/A. The body braking during Dynamic VID is disabled.

IR3086 EXTERNAL COMPONENTS

PWM Ramp Resistor *RPWMRMP* and Capacitor *CPWMRMP*

Set PWM ramp magnitude $V_{PWMRMP}=0.8V$. Choose 220pF for PWM ramp capacitor $CPWMRMP$, and calculate the resistor $RPWMRMP$,

$$R_{PWMRMP} = \frac{V_O}{V_{IN} * f_{SW} * C_{PWMRMP} * [\ln(V_{IN} - V_{DAC}) - \ln(V_{IN} - V_{DAC} - V_{PWMRMP})]}$$

$$= \frac{1.33}{12 * 400 * 10^3 * 220 * 10^{-12} * [\ln(12 - 1.35) - \ln(12 - 1.35 - 0.8)]} = 16.1k\Omega, \text{ Choose } RPWMRMP=16.2k\Omega$$

Inductor Current Sensing Capacitor *Ccs+* and Resistors *Rcs+* and *Rcs-*

Choose $C_{CS+}=47nF$ and calculate R_{CS+} ,

$$R_{CS+} = \frac{L/R_L}{C_{CS+}} = \frac{220 * 10^{-9} / (0.47 * 10^{-3})}{47 * 10^{-9}} = 10.0k\Omega$$

The bias currents of $CSIN+$ and $CSIN-$ are 0.25uA and 0.4uA respectively. Calculate resistor R_{CS-} ,

$$R_{CS-} = \frac{0.25}{0.4} * R_{CS+} = \frac{0.25}{0.4} * 10.0 * 10^3 = 6.2k\Omega, \text{ Choose } R_{CS-}=6.19k\Omega$$

Over Temperature Setting Resistors *RHOTSET1* and *RHOTSET2*

Use central over temperature setting and set the temperature threshold at 115 °C, which corresponds the IC die temperature of 116 °C. Calculate the HOTSET threshold voltage corresponding to the temperature thresholds.

$$V_{HOTSET} = 4.73 * 10^{-3} * T_J + 1.241 = 4.73 * 10^{-3} * 116 + 1.241 = 1.79V$$

Pre-select $RHOTSET1=10.0k\Omega$,

$$R_{HOTSET2} = \frac{R_{HOTSET1} * V_{HOTSET}}{V_{BIAS} - V_{HOTSET}} = \frac{10 * 10^3 * 1.79}{6.8 - 1.79} = 3.57k\Omega$$

Phase Delay Timing Resistors *RPHASE1* and *RPHASE2*

Use central over temperature setting and set the temperature threshold at 115 °C, which corresponds the IC die temperature of 116 °C. Calculate the HOTSET threshold voltage corresponding to the temperature thresholds.

The phase delay resistor ratios for phases 1 to 6 at 400kHz of switching frequencies are R_{PHASE1}=0.628, R_{PHASE2}=0.415, R_{PHASE3}=0.202, R_{PHASE4}=0.246, R_{PHASE5}=0.441 and R_{PHASE6}=0.637 starting from down-slope. Pre-select R_{PHASE11}=R_{PHASE21}=R_{PHASE31}=R_{PHASE41}=R_{PHASE51}= R_{PHASE61}=10kΩ,

$$R_{PHASE12} = \frac{R_{APHA5E1}}{1 - R_{APHA5E1}} * R_{PHASE11} = \frac{0.628}{1 - 0.628} * 10 * 10^3 = 16.9k\Omega$$

R_{PHASE22}=7.15kΩ, R_{PHASE32}=2.55kΩ, R_{PHASE42}=3.24kΩ, P_{PHASE52}=7.87kΩ, R_{PHASE62}=17.4kΩ

Bootstrap Capacitor CBST

Choose CBST=0.1uF

Decoupling Capacitors for Phase IC and Power Stage

Choose C_{VCC}=0.1uF, C_{VCCCL}=0.1uF

VOLTAGE LOOP COMPENSATION

Type II compensation is used for the converter with AL-Polymer output capacitors. Choose the crossover frequency f_c=40kHz, which is 1/10 of the switching frequency per phase, and determine R_{cp} and C_{CP}.

$$R_{CP} = \frac{(2\pi * f_c)^2 * L_E * C_E * R_{FB} * V_{RAMP}}{V_O * \sqrt{1 + (2\pi * f_c * C * R_C)^2}} = \frac{(2\pi * 40 * 10^3)^2 * (220 * 10^{-9} / 6) * (560 * 10^{-6} * 10) * 365 * 0.8}{(1.35 - 20 * 10^{-3}) * \sqrt{1 + (2\pi * 40 * 10^3 * 560 * 10^{-6} * 7 * 10^{-3})^2}} = 2.0k\Omega$$

$$C_{CP} = \frac{10 * \sqrt{L_E * C_E}}{R_{CP}} = \frac{10 * \sqrt{(220 * 10^{-9} / 6) * (560 * 10^{-6} * 10)}}{2.0 * 10^3} = 71nF, \text{ Choose } C_{CP}=68nF$$

Choose C_{CP1}=47pF to reduce high frequency noise.

CURRENT SHARE LOOP COMPENSATION

The crossover frequency of the current share loop f_{ci} should be at least one decade lower than that of the voltage loop f_c. Choose the crossover frequency of current share loop f_{ci}=4kHz, and calculate C_{SCOMP},

$$F_{MI} = \frac{R_{PWRMP} * C_{PWRMP} * f_{SW} * V_{PWRMP}}{(V_I - V_{PWRMP} - V_{DAC}) * (V_I - V_{DAC})} = \frac{16.2 * 10^3 * 220 * 10^{-12} * 400 * 10^3 * 0.8}{(12 - 0.8 - 1.35) * (12 - 1.35)} = 0.011$$

$$C_{SCOMP} = \frac{0.65 * R_{PWRMP} * V_I * I_O * G_{CS_ROOM} * R_{LE} * [1 + 2\pi * f_{CI} * C_E * (V_O / I_O)] * F_{MI}}{V_O * 2\pi * f_{CI} * 1.05 * 10^6}$$

$$= \frac{0.65 * 16.2 * 10^3 * 12 * 105 * 34 * (0.47 * 10^{-3} / 6) * [1 + 2\pi * 4 * 10^3 * 560 * 10^{-6} * 10 * (1.33 - 105 * 9.1 * 10^{-4}) / 105] * 0.011}{(1.33 - 105 * 9.1 * 10^{-4}) * 2\pi * 4 * 10^3 * 1.05 * 10^6}$$

$$= 31.4nF$$

Choose C_{SCOMP}=33nF.

DESIGN EXAMPLE 2 - EVRD 10 HIGH FREQUENCY ALL-CERAMIC CONVERTER

SPECIFICATIONS

Input Voltage: $V_I=12\text{ V}$
 DAC Voltage: $V_{DAC}=1.3\text{ V}$
 No Load Output Voltage Offset: $V_{O_NLOFST}=20\text{ mV}$
 Output Current: $I_O=105\text{ ADC}$
 Maximum Output Current: $I_{OMAX}=120\text{ ADC}$
 Output Impedance: $R_O=0.91\text{ m}\Omega$
 VCC Ready to VCC Power Good Delay: $t_{VCCPG}=0\text{-}10\text{mS}$
 VID Delay Time: $t_{VID}=2.5\text{mS}$
 Soft Start Time: $t_{SS}=2.9\text{mS}$
 Over Current Delay: $t_{OCDEL}=2.1\text{mS}$
 Dynamic VID Down-Slope Slew Rate: $SR_{DOWN}=2.5\text{mV/uS}$
 Over Temperature Threshold: $T_{PCB}=115\text{ }^\circ\text{C}$

POWER STAGE

Phase Number: $n=6$
 Switching Frequency: $f_{sw}=800\text{ kHz}$
 Output Inductors: $L=100\text{ nH}$, $R_L=0.5\text{ m}\Omega$
 Output Capacitors: Ceramic, $C=22\text{uF}$, $R_C=2\text{m}\Omega$, Number $C_n=62$

IR3080 EXTERNAL COMPONENTS

Oscillator Resistor R_{osc}

Once the switching frequency is chosen, R_{OSC} can be determined from the curve in Figure 13. For switching frequency of 800kHz per phase, choose $R_{OSC}=13.3\text{k}\Omega$

VID Delay Capacitor C_{VIDDEL}

Given VID delay time $t_{VID}=2.5\text{mS}$, the capacitor can is,

$$C_{VIDDEL} = \frac{66 * 10^{-6} * t_{VID}}{3.91} = \frac{66 * 10^{-6} * 2.5 * 10^{-3}}{3.91} = 42\text{nF}, \text{ choose } 47\text{nF}$$

Soft Start Capacitor $C_{SS/DEL}$ and Resistor $R_{SS/DEL}$

Because faster over-current protection is required, the soft start capacitor $C_{SS/DEL}$ in series with the resistor $R_{SS/DEL}$ is used. Calculate the soft start capacitor from the required soft start time.

$$C_{SS/DEL} = \frac{I_{CHG} * t_{SS}}{V_O} = \frac{70 * 10^{-6} * 2.9 * 10^{-3}}{1.3 - 20 * 10^{-3}} = 0.16\text{uF}, \text{ choose } C_{SS/DEL}=0.15\text{uF}$$

Calculate the soft start resistor from the required over current delay time t_{OCDEL} ,

$$R_{SS/DEL} = \frac{0.09 - \frac{t_{OCDEL} * I_{DISCHG}}{C_{SS/DEL}}}{I_{DISCHG}} = \frac{0.09 - \frac{2.1 * 10^{-3} * 6 * 10^{-6}}{0.15 * 10^{-6}}}{6 * 10^{-6}} = 1\text{k}\Omega$$

The soft start delay time is

$$t_{SSDEL} = \frac{C_{SS/DEL} * (1.3 - R_{SS/DEL} * I_{CHG})}{I_{CHG}} = \frac{0.15 * 10^{-6} * (1.3 - 1 * 10^3 * 70 * 10^{-6})}{70 * 10^{-6}} = 2.6\text{mS}$$

The power good delay time is

$$t_{V_{cc}PG} = \frac{C_{SS/DEL} * (3.91 - V_O - 1.3)}{I_{CHG}} = \frac{0.15 * 10^{-6} * (3.91 - 1.28 - 1.3)}{70 * 10^{-6}} = 2.85ms$$

VDAC Slew Rate Programming Capacitor C_{VDAC} and Resistor R_{VDAC}

From Figure 15, the sink current of VDAC pin corresponding to 800kHz ($R_{osc}=13.3k\Omega$) is 170uA. Calculate the VDAC down-slope slew-rate programming capacitor from the required down-slope slew rate.

$$C_{VDAC} = \frac{I_{SINK}}{SR_{DOWN}} = \frac{170 * 10^{-6}}{2.5 * 10^{-3} / 10^{-6}} = 68nF$$

Calculate the programming resistor.

$$R_{VDAC} = 0.5 + \frac{3.2 * 10^{-15}}{C_{VDAC}^2} = 0.5 + \frac{3.2 * 10^{-15}}{(68 * 10^{-9})^2} = 1.2\Omega$$

From Figure 15, the source current of VDAC pin is 250uA. The VDAC up-slope slew rate is

$$SR_{UP} = \frac{I_{SOURCE}}{C_{VDAC}} = \frac{250 * 10^{-6}}{68 * 10^{-9}} = 3.7mV / \mu S$$

Over Current Setting Resistor R_{OCSET}

The room temperature is 25°C and the target PCB temperature is 100 °C. The phase IC die temperature is about 1 °C higher than that of phase IC, and the inductor temperature is close to PCB temperature.

Calculate Inductor DC resistance at 100 °C,

$$R_{L_MAX} = R_{L_ROOM} * [1 + 3850 * 10^{-6} * (T_{L_MAX} - T_{ROOM})] = 0.5 * 10^{-3} * [1 + 3850 * 10^{-6} * (100 - 25)] = 0.64m\Omega$$

The current sense amplifier gain is 34 at 25°C, and its gain at 101°C is calculated as,

$$G_{CS_MIN} = G_{CS_ROOM} * [1 - 1470 * 10^{-6} * (T_{IC_MAX} - T_{ROOM})] = 34 * [1 - 1470 * 10^{-6} * (101 - 25)] = 30.2$$

Set the over current limit at 135A. From Figure 14, the bias current of OCSET pin (I_{OCSET}) is 90uA with $R_{osc}=13.3k\Omega$. The total current sense amplifier input offset voltage is 0.55mV, which includes the offset created by the current sense amplifier input resistor mismatch.

Calculate constant K_P , the ratio of inductor peak current over average current in each phase,

$$K_P = \frac{(V_I - V_O) * V_O / (L * V_I * f_{SW} * 2)}{I_{LIMIT} / n} = \frac{(12 - 1.28) * 1.28 / (100 * 10^{-9} * 12 * 800 * 10^3 * 2)}{135 / 6} = 0.32$$

$$R_{OCSET} = \left[\frac{R_{LIMIT}}{n} * R_{L_MAX} * (1 + K_P) + V_{CS_TOFST} \right] * G_{CS_MIN} / I_{OCSET}$$

$$= \left(\frac{135}{6} * 0.64 * 10^{-3} * 1.32 + 0.55 * 10^{-3} \right) * 30.2 / (90 * 10^{-6}) = 6.34k\Omega$$

No Load Output Voltage Setting Resistor R_{FB} and Adaptive Voltage Positioning Resistor R_{DRP}

From Figure 14, the bias current of FB pin is 90uA with $R_{osc}=13.3k\Omega$.

$$R_{FB} = \frac{R_{L_MAX} * V_{O_NLOFST} - V_{CS_TOFST} * n * R_O}{I_{FB} * R_{L_MAX}} = \frac{0.64 * 10^{-3} * 20 * 10^{-3} - 0.55 * 10^{-3} * 6 * 0.91 * 10^{-3}}{90 * 10^{-6} * 0.64 * 10^{-3}} = 162\Omega$$

$$R_{DRP} = \frac{R_{FB} * R_{L_MAX} * G_{CS_MIN}}{n * R_O} = \frac{162 * 0.64 * 10^{-3} * 30.2}{6 * 0.91 * 10^{-3}} = 576\Omega$$

Control IC Over Temperature Setting Resistors RHOTSETC1 and RHOTSETC2

Set the temperature threshold at 115 °C, which corresponds the IC die temperature of 116 °C. Calculate the HOTSET threshold voltage corresponding to the temperature thresholds.

$$V_{HOTSET} = 4.73 * 10^{-3} * T_J + 1.241 = 4.73 * 10^{-3} * 116 + 1.241 = 1.79V, \text{ choose } R_{HOTSETC1}=10.0k\Omega,$$

$$R_{HOTSETC2} = \frac{R_{HOTSETC1} * V_{HOTSET}}{V_{BIAS} - V_{HOTSET}} = \frac{10 * 10^3 * 1.79}{6.8 - 1.79} = 3.57k\Omega$$

Body Braking Related Resistors RBBFB and RBBDRP

N/A. The body braking during Dynamic VID is disabled.

IR3086 EXTERNAL COMPONENTS

PWM Ramp Resistor RPWMRMP and Capacitor CPWMRMP

Set PWM ramp magnitude VPWMRMP=0.75V. Choose 100pF for PWM ramp capacitor CPWMRMP, and calculate the resistor RPWMRMP,

$$R_{PWMRMP} = \frac{V_O}{V_{IN} * f_{SW} * C_{PWMRMP} * [\ln(V_{IN} - V_{DAC}) - \ln(V_{IN} - V_{DAC} - V_{PWMRMP})]}$$

$$= \frac{1.28}{12 * 800 * 10^3 * 100 * 10^{-12} * [\ln(12 - 1.3) - \ln(12 - 1.3 - 0.75)]} = 18.2k\Omega$$

Inductor Current Sensing Capacitor CCS+ and Resistors RCS+ and RCS-

Choose 47nF for capacitor CCS+ and calculate RCS+,

$$R_{CS+} = \frac{L/R_L}{C_{CS+}} = \frac{100 * 10^{-9} / (0.5 * 10^{-3})}{47 * 10^{-9}} = 4.22k\Omega$$

The bias currents of CSIN+ and CSIN- are 0.25uA and 0.4uA respectively. Calculate resistor RCS-,

$$R_{CS-} = \frac{0.25}{0.4} * R_{CS+} = \frac{0.25}{0.4} * 4.22 * 10^3 = 2.61k\Omega$$

Combined Over Temperature and Phase Delay Setting Resistors RPHASEx1, RPHASEx2 and RPHASEx3

The over temperature setting resistor divider is combined with the phase delay resistor divider. Set the temperature threshold at 115 °C, which corresponds the IC die temperature of 116 °C, and calculate the HOTSET threshold voltage corresponding to the temperature thresholds.

$$V_{HOTSET} = 4.73 * 10^{-3} * T_J + 1.241 = 4.73 * 10^{-3} * 116 + 1.241 = 1.79V$$

The phase delay resistor ratios for phases 1 to 6 at 800kHz of switching frequencies are RAPHASE1=0.665, RAPHASE2=0.432, RAPHASE3=0.198, RAPHASE4=0.206, RAPHASE5=0.401 and RAPHASE6=0.597 starting from down-slope.

The over temperature setting voltage of phases 1, 2, 5, and 6 is lower than the phase delay setting voltage, $V_{BIAS} * R_{PHASEx}$. Pre-select $R_{PHASE11}=10k\Omega$,

$$R_{PHASEx2} = \frac{(R_{PHASEx} * V_{BIAS} - V_{HOTSET}) * R_{PHASEx1}}{V_{BIAS} * (1 - R_{PHASEx})} = \frac{(0.665 * 6.8 - 1.79) * 10 * 10^3}{6.8 * (1 - 0.665)} = 12.1k\Omega$$

$$R_{PHASEx3} = \frac{V_{HOTSET} * R_{PHASEx1}}{V_{BIAS} * (1 - R_{PHASEx})} = \frac{1.79 * 12.1 * 10^3}{6.8 * (1 - 0.665)} = 7.87k\Omega$$

$R_{PHASE21}=10k\Omega$, $R_{PHASE22}=2.94k\Omega$, $R_{PHASE23}=4.64k\Omega$

$R_{PHASE51}=10k\Omega$, $R_{PHASE52}=2.32k\Omega$, $R_{PHASE53}=4.42k\Omega$

$R_{PHASE61}=10k\Omega$, $R_{PHASE62}=8.25k\Omega$, $R_{PHASE63}=6.49k\Omega$

The over temperature setting voltage of Phases 3 and 4 is higher than the phase delay setting voltage, $V_{BIAS} * R_{PHASEx}$. Pre-select $R_{PHASEx1}=10k\Omega$,

$$R_{PHASE32} = \frac{(V_{HOTSET} - R_{PHASE3} * V_{BIAS}) * R_{PHASE31}}{V_{BIAS} - V_{HOTSET}} = \frac{(1.79 - 0.198 * 6.8) * 10 * 10^3}{6.8 - 1.79} = 887\Omega$$

$$R_{PHASE33} = \frac{R_{PHASE3} * V_{BIAS} * R_{PHASE31}}{V_{BIAS} - V_{HOTSET}} = \frac{0.198 * 6.8 * 10 * 10^3}{6.8 - 1.79} = 2.67k\Omega$$

$R_{PHASE41}=10k\Omega$, $R_{PHASE42}=768\Omega$, $R_{PHASE43}=2.80k\Omega$

Bootstrap Capacitor C_{BST}

Choose $C_{BST}=0.1\mu F$

Decoupling Capacitors for Phase IC and Power Stage

Choose $C_{VCC}=0.1\mu F$, $C_{VCL}=0.1\mu F$

VOLTAGE LOOP COMPENSATION

Type III compensation is used for the converter with only ceramic output capacitors. The crossover frequency and phase margin of the voltage loop can be estimated as follows.

$$f_{C1} = \frac{R_{DRP}}{2\pi * C_E * G_{CS} * R_{FB} * R_{LE}} = \frac{576}{2\pi * (62 * 22 * 10^{-6}) * 34 * 162 * (0.5 * 10^{-3} / 6)} = 146kHz$$

$$\theta_{C1} = 90 - A \tan(0.5) * \frac{180}{\pi} = 63^\circ$$

$$\text{Choose } R_{FB1} = \frac{2}{3} * R_{FB} = \frac{2}{3} * 162 = 110\Omega$$

Choose the desired crossover frequency f_c ($=140kHz$) around f_{c1} estimated above, and calculate

$$C_{FB} = \frac{1}{4\pi * f_c * R_{FB1}} = \frac{1}{4\pi * 140 * 10^3 * 110} = 5.2nF, \text{ Choose } C_{FB}=5.6nF$$

$$C_{DRP} = \frac{(R_{FB} + R_{FB1}) * C_{FB}}{R_{DRP}} = \frac{(162 + 110) * 5.6 * 10^{-9}}{576} = 2.7nF$$

$$R_{CP} = \frac{(2\pi * f_C)^2 * L_E * C_E * R_{FB} * V_{RAMP}}{V_O} = \frac{(2\pi * 140 * 10^3)^2 * (100 * 10^{-9} / 6) * (22 * 10^{-6} * 62) * 162 * 0.75}{1.3 - 20 * 10^{-3}} = 1.65k\Omega$$

$$C_{CP} = \frac{10 * \sqrt{L_E * C_E}}{R_{CP}} = \frac{10 * \sqrt{(100 * 10^{-9} / 6) * (22 * 10^{-6} * 62)}}{1.65 * 10^3} = 27nF$$

Choose C_{CP1}=47pF to reduce high frequency noise.

CURRENT SHARE LOOP COMPENSATION

The crossover frequency of the current share loop f_{CI} should be at least one decade lower than that of the voltage loop f_C . Choose the crossover frequency of current share loop f_{CI} =3.5kHz, and calculate C_{SCOMP} ,

$$F_{MI} = \frac{R_{PWMRMP} * C_{PWMRMP} * f_{SW} * V_{PWMRMP}}{(V_I - V_{PWMRMP} - V_{DAC}) * (V_I - V_{DAC})} = \frac{18.2 * 10^3 * 100 * 10^{-12} * 800 * 10^3 * 0.75}{(12 - 0.75 - 1.3) * (12 - 1.3)} = 0.011$$

$$C_{SCOMP} = \frac{0.65 * R_{PWMRMP} * V_I * I_O * G_{CS_ROOM} * R_{LE} * [1 + 2\pi * f_{CI} * C_E * (V_O / I_O)] * F_{MI}}{V_O * 2\pi * f_{CI} * 1.05 * 10^6}$$

$$= \frac{0.65 * 18.2 * 10^3 * 12 * 105 * 34 * (0.5 * 10^{-3} / 6) * [1 + 2\pi * 3500 * 22 * 10^{-6} * 62 * (1.33 - 105 * 9.1 * 10^{-4}) / 105] * 0.011}{(1.33 - 105 * 9.1 * 10^{-4}) * 2\pi * 3500 * 1.05 * 10^6}$$

$$= 20.6nF$$

Choose C_{SCOMP}=22nF

LAYOUT GUIDELINES

The following layout guidelines are recommended to reduce the parasitic inductance and resistance of the PCB layout, therefore minimizing the noise coupled to the IC.

- Dedicate at least one middle layer for a ground plane LGND.
- Connect the ground tab under the control IC to LGND plane through a via.
- Place the following critical components on the same layer as control IC and position them as close as possible to the respective pins, RO SC, ROCSET, RVDAC, CVDAC, CVCC, CSS/DEL and RCC/DEL. Avoid using any via for the connection.
- Place the compensation components on the same layer as control IC and position them as close as possible to EAOUT, FB and VDRP pins. Avoid using any via for the connection.
- Use Kelvin connections for the remote voltage sense signals, VOSNS+ and VOSNS-, and avoid crossing over the fast transition nodes, i.e. switching nodes, gate drive signals and bootstrap nodes.
- Control bus signals, VDAC, RMPOUT, IIN, VBIAS, and especially EAOUT, should not cross over the fast transition nodes.

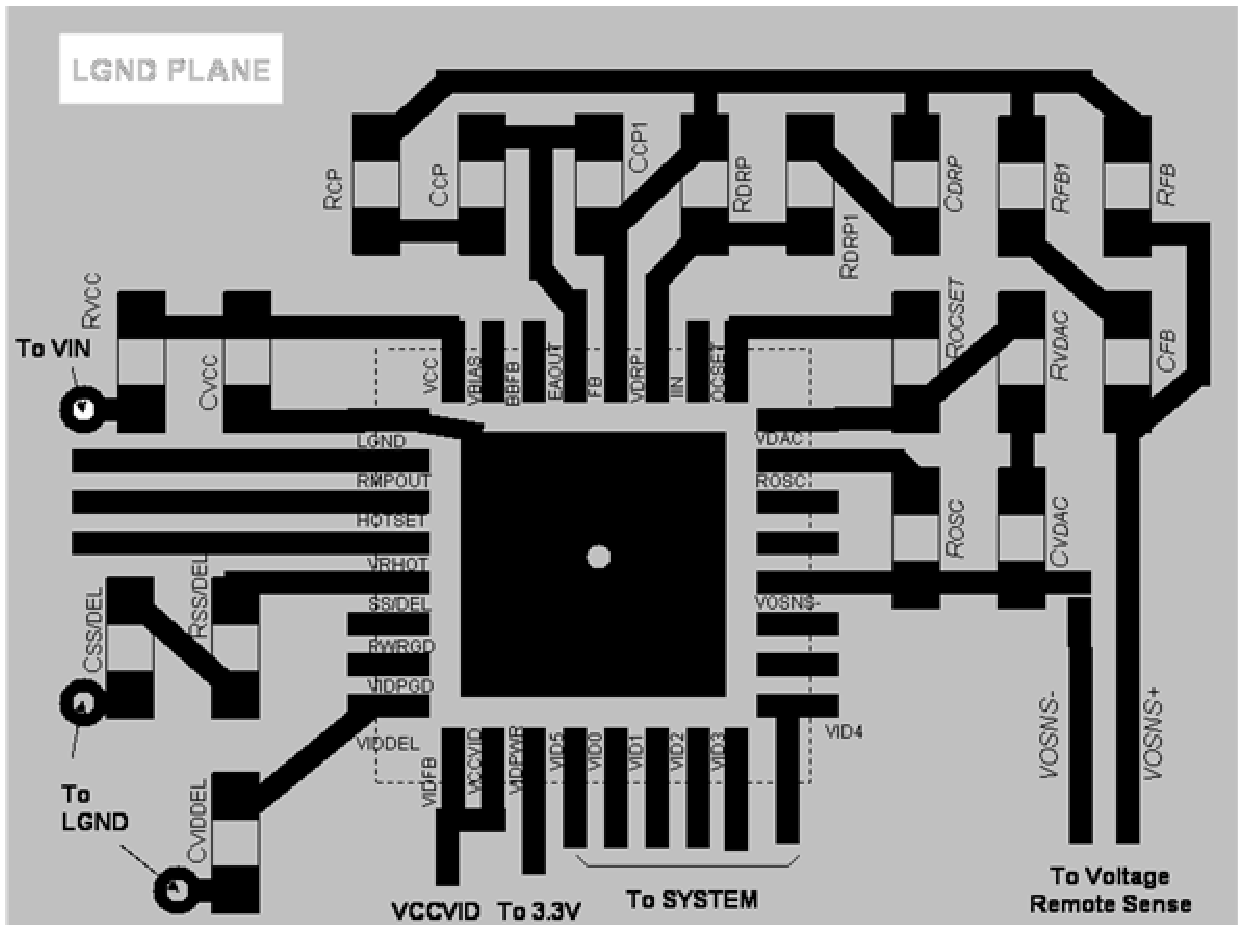

PCB Metal and Component Placement

- Lead land width should be equal to nominal part lead width. The minimum lead to lead spacing should be $\geq 0.2\text{mm}$ to minimize shorting.
- Lead land length should be equal to maximum part lead length + 0.2 mm outboard extension + 0.05mm inboard extension. The outboard extension ensures a large and inspectable toe fillet, and the inboard extension will accommodate any part misalignment and ensure a fillet.
- Center pad land length and width should be equal to maximum part pad length and width. However, the minimum metal to metal spacing should be $\geq 0.17\text{mm}$ for 2 oz. Copper ($\geq 0.1\text{mm}$ for 1 oz. Copper and $\geq 0.23\text{mm}$ for 3 oz. Copper)
- A single 0.30mm diameter via shall be placed in the center of the pad land and connected to ground to minimize the noise effect on the IC.

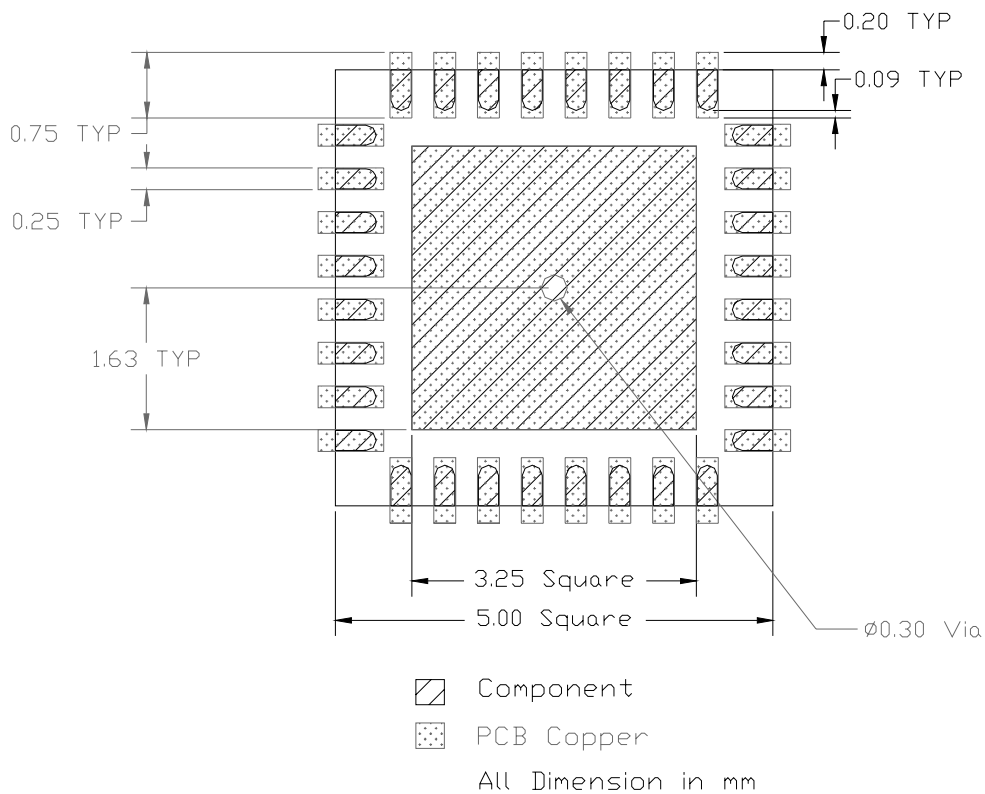

Solder Resist

- The solder resist should be pulled away from the metal lead lands by a minimum of 0.06mm. The solder resist mis-alignment is a maximum of 0.05mm and it is recommended that the lead lands are all Non Solder Mask Defined (NSMD). Therefore pulling the S/R 0.06mm will always ensure NSMD pads.
- The minimum solder resist width is 0.13mm, therefore it is recommended that the solder resist is completely removed from between the lead lands forming a single opening for each “group” of lead lands.
- At the inside corner of the solder resist where the lead land groups meet, it is recommended to provide a fillet so a solder resist width of $\geq 0.17\text{mm}$ remains.
- The land pad should be Solder Mask Defined (SMD), with a minimum overlap of the solder resist onto the copper of 0.06mm to accommodate solder resist mis-alignment. In 0.5mm pitch cases it is allowable to have the solder resist opening for the land pad to be smaller than the part pad.
- Ensure that the solder resist in-between the lead lands and the pad land is $\geq 0.15\text{mm}$ due to the high aspect ratio of the solder resist strip separating the lead lands from the pad land.
- The single via in the land pad should be tented with solder resist 0.4mm diameter, or 0.1mm larger than the diameter of the via.

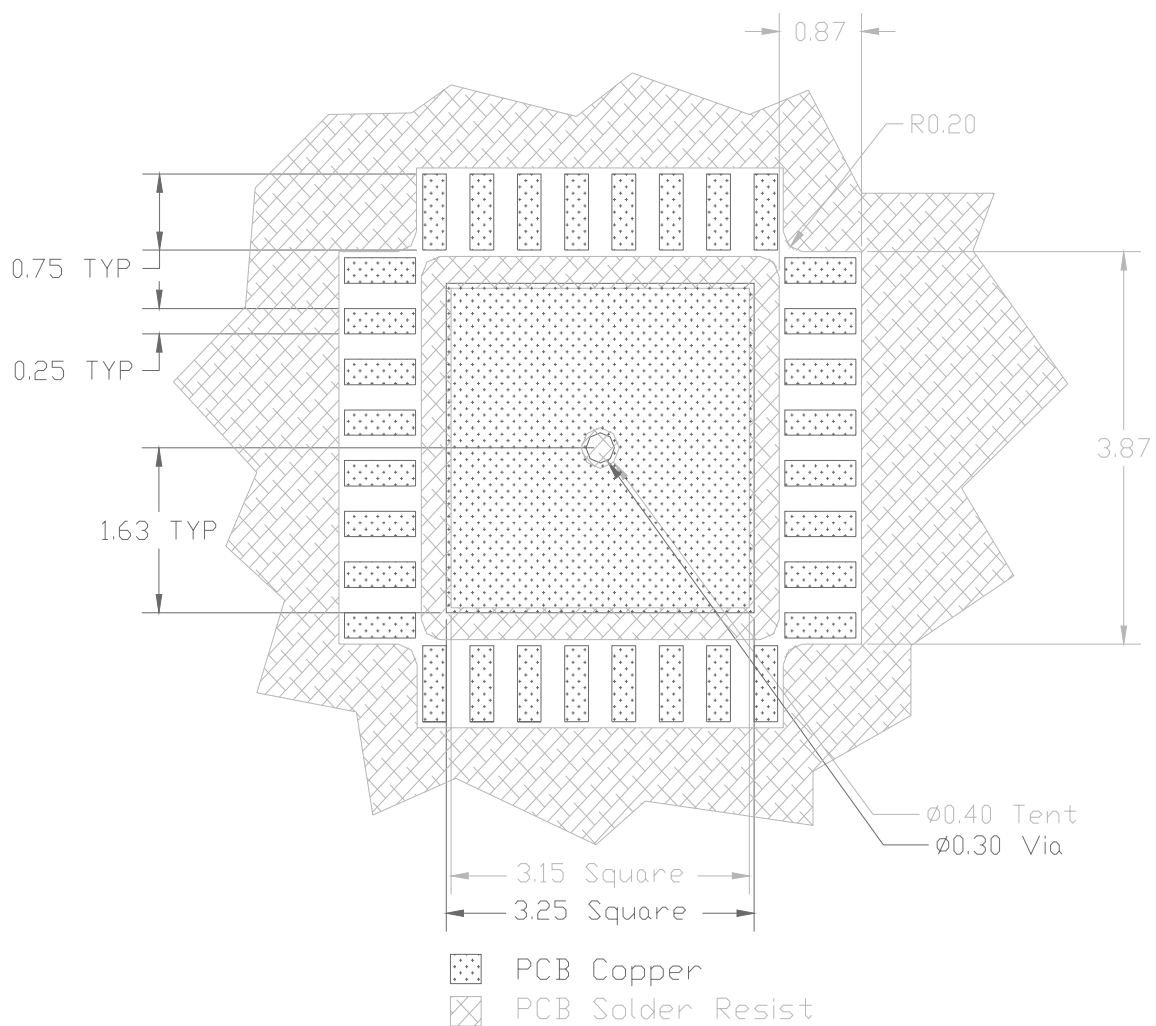

All Dimensions in mm

Stencil Design

- The stencil apertures for the lead lands should be approximately 80% of the area of the lead lands. Reducing the amount of solder deposited will minimize the occurrence of lead shorts. Since for 0.5mm pitch devices the leads are only 0.25mm wide, the stencil apertures should not be made narrower; openings in stencils < 0.25mm wide are difficult to maintain repeatable solder release.
- The stencil lead land apertures should therefore be shortened in length by 80% and centered on the lead land.
- The land pad aperture should be striped with 0.25mm wide openings and spaces to deposit approximately 50% area of solder on the center pad. If too much solder is deposited on the center pad the part will float and the lead lands will be open.
- The maximum length and width of the land pad stencil aperture should be equal to the solder resist opening minus an annular 0.2mm pull back to decrease the incidence of shorting the center land to the lead lands when the part is pushed into the solder paste.

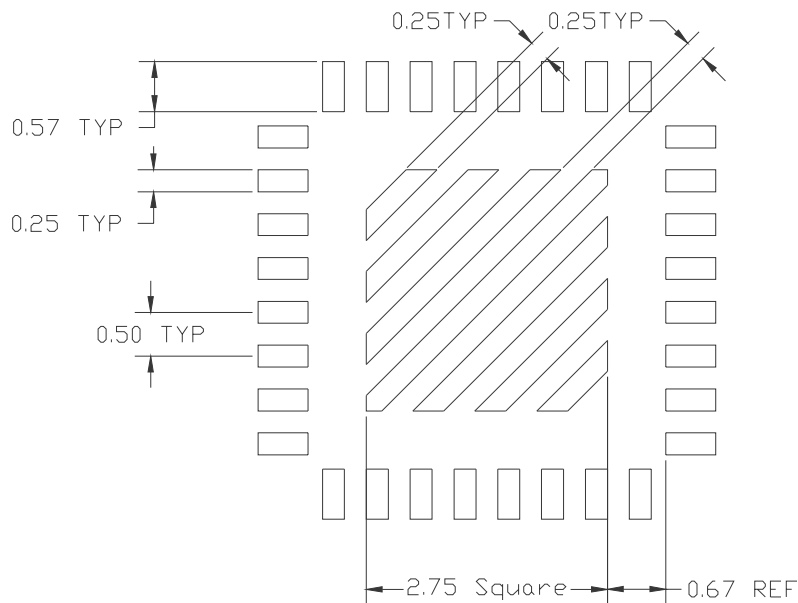

Stencil Aperture
All Dimensions in mm

TYPICAL PERFORMANCE CHARACTERISTICS

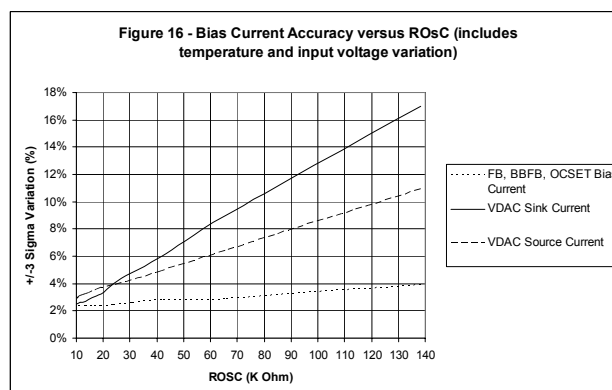
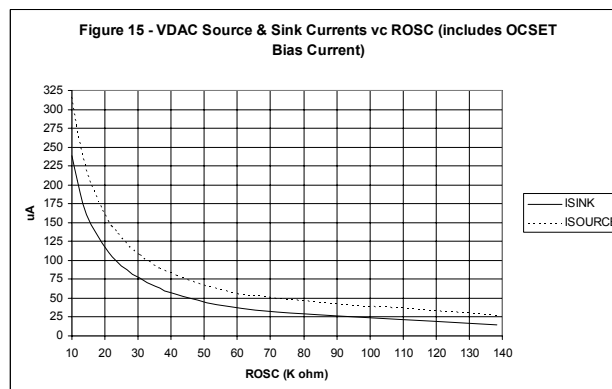
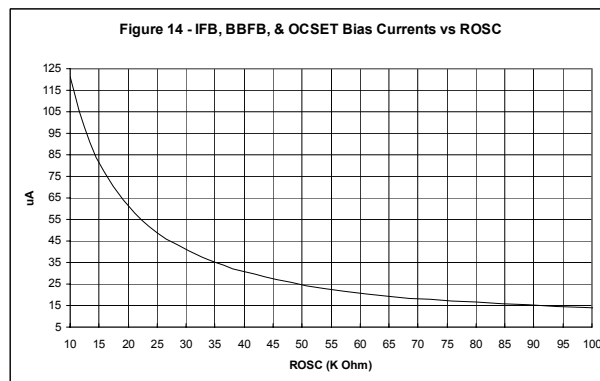
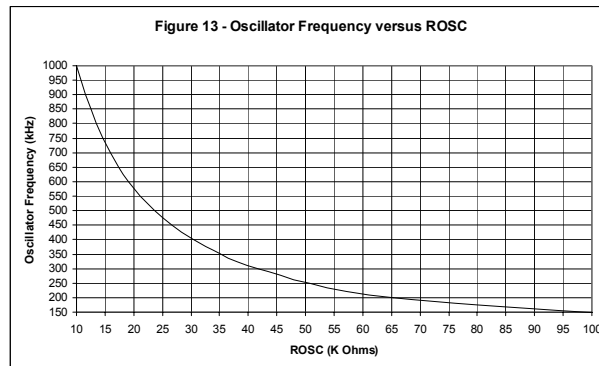

PACKAGE INFORMATION

32L MLPQ (5 x 5 mm Body) – $\theta_{JA} = 30^{\circ}\text{C/W}$, $\theta_{JC} = 3^{\circ}\text{C/W}$

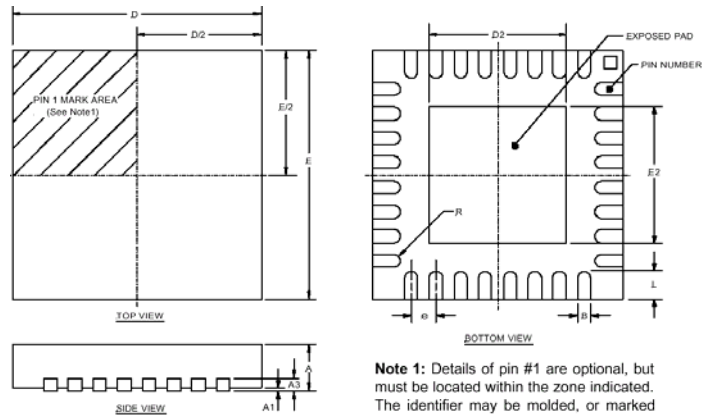

Note 1: Details of pin #1 are optional, but must be located within the zone indicated. The identifier may be molded, or marked features.

SYMBOL	32-PIN 5x5			
	DESIG	MIN	NOM	MAX
A	0.80	0.90	1.00	
A1	0.00	0.02	0.05	
A3		0.20 REF		
B	0.18	0.23	0.30	
D		5.00 BSC		
D2	3.00	3.15	3.25	
E		5.00 BSC		
E2	3.00	3.15	3.25	
e		0.50 BSC		
L	0.30	0.40	0.50	
R	0.09	---	---	

NOTE: ALL MEASUREMENTS ARE IN MILLIMETERS.

Data and specifications subject to change without notice. This product has been designed and qualified for the Consumer market. Qualification Standards can be found on IR's Web site.