

# IS41C85125 IS41LV85125



## 512K x 8 (4-MBIT) DYNAMIC RAM WITH FAST PAGE MODE

PRELIMINARY INFORMATION  
AUGUST 2001

### FEATURES

- Fast access and cycle time
- TTL compatible inputs and outputs
- Refresh Interval: 1024 cycles/16 ms
- Refresh Mode:  $\overline{\text{RAS}}$ -Only,  $\overline{\text{CAS}}$ -before- $\overline{\text{RAS}}$  (CBR), and Hidden
- JEDEC standard pinout
- Single power supply:
  - $5V \pm 10\%$  (IS41C85125)
  - $3.3V \pm 10\%$  (IS41LV85125)
- Industrial temperature available

### DESCRIPTION

The *ISSI* IS41C85125 and IS41LV85125 are 512,288 x 8-bit high-performance CMOS Dynamic Random Access Memories. Fast Page Mode allows 1024 random accesses within a single row with access cycle time as short as 12 ns per 8-bit word.

These features make the IS41C85125 and the IS41LV85125 ideally suited for high band-width graphics, digital signal processing, high-performance computing systems, and peripheral applications.

The IS41C85125 and IS41LV85125 are available in a 28-pin, 400-mil SOJ package.

### KEY TIMING PARAMETERS

Parameter	-35	-60	Unit
Max. $\overline{\text{RAS}}$ Access Time ( $t_{\text{RAC}}$ )	35	60	ns
Max. $\overline{\text{CAS}}$ Access Time ( $t_{\text{CAC}}$ )	10	15	ns
Max. Column Address Access Time ( $t_{\text{AA}}$ )	18	30	ns
Min. Fast Page Mode Cycle Time ( $t_{\text{PC}}$ )	12	25	ns
Min. Read/Write Cycle Time ( $t_{\text{RC}}$ )	60	110	ns

### PIN DESCRIPTIONS

A0-A9	Address Inputs
I/O0-I/O7	Data Inputs/Outputs
$\overline{\text{WE}}$	Write Enable
$\overline{\text{OE}}$	Output Enable
$\overline{\text{RAS}}$	Row Address Strobe
$\overline{\text{CAS}}$	Column Address Strobe
Vcc	Power
GND	Ground
NC	No Connection

### PIN CONFIGURATION

#### 28-Pin SOJ

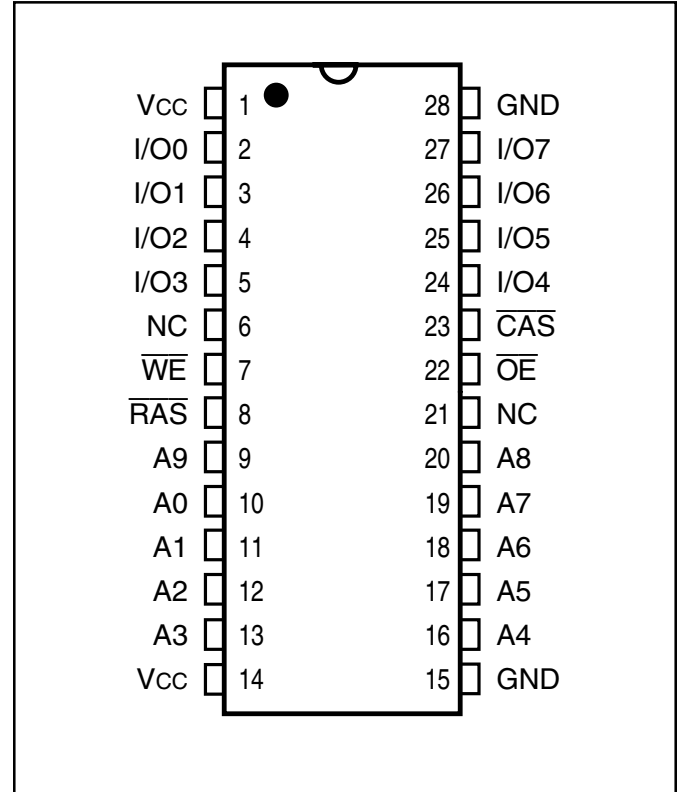

This document contains PRELIMINARY INFORMATION data. ISSI reserves the right to make changes to its products at any time without notice in order to improve design and supply the best possible product. We assume no responsibility for any errors which may appear in this publication. © Copyright 2001, Integrated Silicon Solution, Inc.

**FUNCTIONAL BLOCK DIAGRAM**

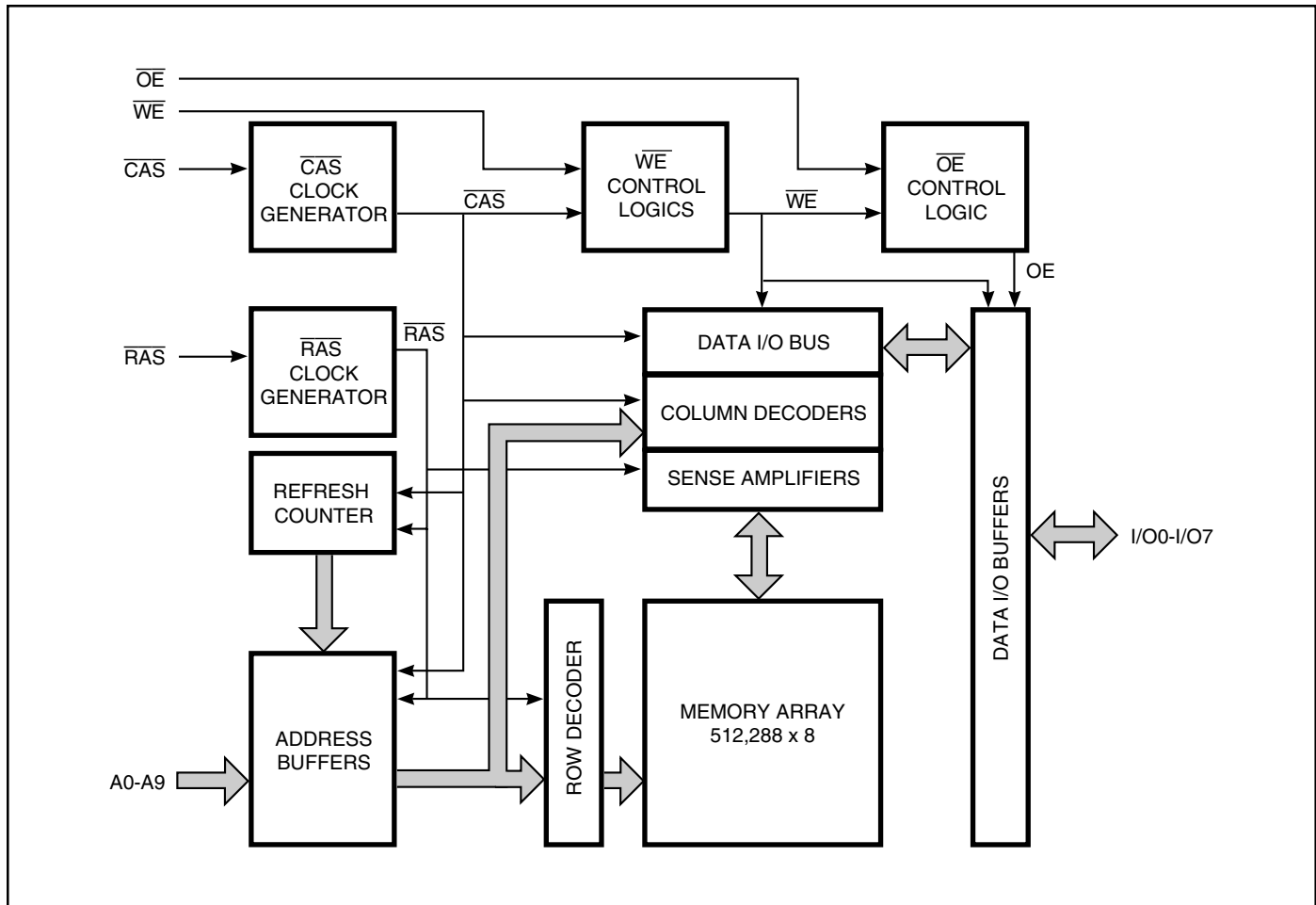

**TRUTH TABLE**

Function	RAS	CAS	WE	OE	Address tr/tc	I/O
Standby	H	H	X	X	X	High-Z
Read	L	L	H	L	ROW/COL	DOUT
Write: Word (Early Write)	L	L	L	X	ROW/COL	DIN
Read-Write	L	L	H→L	L→H	ROW/COL	DOUT, DIN
Hidden Refresh	L→H→L	L	H	L	ROW/COL	DOUT
	L→H→L	L	L	X	ROW/COL	DOUT
RAS-Only Refresh	L	H	X	X	ROW/NA	High-Z
CBR Refresh	H→L	L	X	X	X	High-Z

**Notes:**

1. EARLY WRITE only.

## FUNCTIONAL DESCRIPTION

The IS41C85125 and IS41LV85125 are CMOS DRAMs optimized for high-speed bandwidth, low-power applications. During READ or WRITE cycles, each bit is uniquely addressed through the 19 address bits. The first ten address bits (A0-A9) are entered as row address and latter nine address bits (A0-A8) are entered as column address. The row address is latched by the Row Address Strobe ( $\overline{RAS}$ ). The column address is latched by the Column Address Strobe ( $\overline{CAS}$ ).  $\overline{RAS}$  is used to latch the first ten bits of row address and  $\overline{CAS}$  is used to latch the latter nine bits of column address.

### Memory Cycle

A memory cycle is initiated by bringing  $\overline{RAS}$  LOW and it is terminated by returning both  $\overline{RAS}$  and  $\overline{CAS}$  HIGH. To ensure proper device operation and data integrity any memory cycle, once initiated, must not be ended or aborted before the minimum  $t_{RAS}$  time has expired. A new cycle must not be initiated until the minimum precharge time  $t_{RP}$ ,  $t_{CP}$  has elapsed.

### Read Cycle

A read cycle is initiated by the falling edge of  $\overline{CAS}$  or  $\overline{OE}$ , whichever occurs last, while holding  $\overline{WE}$  HIGH. The column address must be held for a minimum time specified by  $t_{AR}$ . Data Out becomes valid only when  $t_{RAC}$ ,  $t_{AA}$ ,  $t_{CAC}$  and  $t_{OEA}$  are all satisfied. As a result, the access time is dependent on the timing relationships between these parameters.

### Write Cycle

A write cycle is initiated by the falling edge of  $\overline{CAS}$  and  $\overline{WE}$ , whichever occurs last. The input data must be valid

at or before the falling edge of  $\overline{CAS}$  or  $\overline{WE}$ , whichever occurs last.

### Refresh Cycle

To retain data, 1024 refresh cycles are required in each 16 ms period. There are two ways to refresh the memory:

1. By clocking each of the 1024 row addresses (A0 through A9) with  $\overline{RAS}$  at least once every 16 ms. Any read, write, read-modify-write or  $\overline{RAS}$ -only cycle refreshes the addressed row.
2. Using a  $\overline{CAS}$ -before- $\overline{RAS}$  refresh cycle.  $\overline{CAS}$ -before- $\overline{RAS}$  refresh is activated by the falling edge of  $\overline{RAS}$ , while holding  $\overline{CAS}$  LOW. In  $\overline{CAS}$ -before- $\overline{RAS}$  refresh cycle, an internal 10-bit counter provides the row addresses and the external address inputs are ignored.

$\overline{CAS}$ -before- $\overline{RAS}$  is a refresh-only mode and no data access or device selection is allowed. Thus, the output remains in the High-Z state during the cycle.

### Power-On

After application of the  $V_{CC}$  supply, an initial pause of 200  $\mu$ s is required followed by a minimum of eight initialization cycles (any combination of cycles containing a  $\overline{RAS}$  signal).

During power-on, it is recommended that  $\overline{RAS}$  track with  $V_{CC}$  or be held at a valid  $V_{IH}$  to avoid current surges.

**ABSOLUTE MAXIMUM RATINGS<sup>(1)</sup>**

Symbol	Parameters		Rating	Unit
V <sub>T</sub>	Voltage on Any Pin Relative to GND	5V	-1.0 to +7.0	V
		3.3V	-0.5 to +4.6	
V <sub>CC</sub>	Supply Voltage	5V	-1.0 to +7.0	V
		3.3V	-0.5 to +4.6	
I <sub>OUT</sub>	Output Current		50	mA
P <sub>D</sub>	Power Dissipation		1	W
T <sub>A</sub>	Operation Temperature	Com.	0 to 70	°C
		Ind.	-40 to +85	
T <sub>STG</sub>	Storage Temperature		-55 to +125	°C

**Note:**

1. Stress greater than those listed under ABSOLUTE MAXIMUM RATINGS may cause permanent damage to the device. This is a stress rating only and functional operation of the device at these or any other conditions above those indicated in the operational sections of this specification is not implied. Exposure to absolute maximum rating conditions for extended periods may affect reliability.

**RECOMMENDED OPERATING CONDITIONS** (Voltages are referenced to GND)

Symbol	Parameter	Voltage	Min.	Typ.	Max.	Unit
V <sub>CC</sub>	Supply Voltage	5V	4.5	5.0	5.5	V
V <sub>CC</sub>	Supply Voltage	3.3V	3.0	3.3	3.6	V
V <sub>IH</sub>	Input High Voltage	5V	2.4	—	V <sub>CC</sub> + 1.0	V
V <sub>IH</sub>	Input High Voltage	3.3V	2.0	—	V <sub>CC</sub> + 0.3	V
V <sub>IL</sub>	Input Low Voltage	5V	-1.0	—	0.8	V
V <sub>IL</sub>	Input Low Voltage	3.3	-0.3	—	0.8	V
T <sub>A</sub>	Ambient Temperature	Com.	0	—	70	°C
		Ind.	-40	—	85	

**CAPACITANCE<sup>(1,2)</sup>**

Symbol	Parameter	Max.	Unit
C <sub>IN1</sub>	Input Capacitance: A0-A9	5	pF
C <sub>IN2</sub>	Input Capacitance: $\overline{\text{RAS}}$ , $\overline{\text{UCAS}}$ , $\overline{\text{LCAS}}$ , $\overline{\text{WE}}$ , $\overline{\text{OE}}$	7	pF
C <sub>IO</sub>	Data Input/Output Capacitance: I/O0-I/O7	7	pF

**Notes:**

1. Tested initially and after any design or process changes that may affect these parameters.
2. Test conditions: T<sub>A</sub> = 25°C, f = 1 MHz.

**ELECTRICAL CHARACTERISTICS<sup>(1)</sup>** (Recommended Operation Conditions unless otherwise noted.)

Symbol	Parameter	Test Condition	Speed	Min.	Max.	Unit
I <sub>IL</sub>	Input Leakage Current	Any input $0V \leq V_{IN} \leq V_{CC}$ Other inputs not under test = 0V		-10	10	μA
I <sub>IO</sub>	Output Leakage Current	Output is disabled (Hi-Z) $0V \leq V_{OUT} \leq V_{CC}$		-10	10	μA
V <sub>OH</sub>	Output High Voltage Level	I <sub>OH</sub> = -2.5 mA		2.4	—	V
V <sub>OL</sub>	Output Low Voltage Level	I <sub>OL</sub> = 2.1 mA		—	0.4	V
I <sub>CC1</sub>	Stand-by Current: TTL	$\overline{RAS}, \overline{CAS} \geq V_{IH}$	5V Com. 5V Ind. 3.3V Com. 3.3V Ind.	—	2 3 1 2	mA
I <sub>CC2</sub>	Stand-by Current: CMOS	$\overline{RAS}, \overline{CAS} \geq V_{CC} - 0.2V$	5V 3.3V	—	2 1	mA
I <sub>CC3</sub>	Operating Current: Random Read/Write <sup>(2,3,4)</sup> Average Power Supply Current	$\overline{RAS}, \overline{CAS}$ , Address Cycling, t <sub>RC</sub> = t <sub>RC</sub> (min.)	-35 -60	—	230 170	mA
I <sub>CC4</sub>	Operating Current: Fast Page Mode <sup>(2,3,4)</sup> Average Power Supply Current	$\overline{RAS} = V_{IL}, \overline{CAS}$ , Cycling t <sub>PC</sub> = t <sub>PC</sub> (min.)	-35 -60	—	220 160	mA
I <sub>CC5</sub>	Refresh Current: $\overline{RAS}$ -Only <sup>(2,3)</sup> Average Power Supply Current	$\overline{RAS}$ Cycling, $\overline{CAS} \geq V_{IH}$ t <sub>RC</sub> = t <sub>RC</sub> (min.)	-35 -60	—	230 170	mA
I <sub>CC6</sub>	Refresh Current: CBR <sup>(2,3,5)</sup> Average Power Supply Current	$\overline{RAS}, \overline{CAS}$ Cycling t <sub>RC</sub> = t <sub>RC</sub> (min.)	-35 -60	—	230 170	mA

**Notes:**

1. An initial pause of 200 μs is required after power-up followed by eight  $\overline{RAS}$  refresh cycles ( $\overline{RAS}$ -Only or CBR) before proper device operation is assured. The eight  $\overline{RAS}$  cycles wake-up should be repeated any time the t<sub>REF</sub> refresh requirement is exceeded.
2. Dependent on cycle rates.
3. Specified values are obtained with minimum cycle time and the output open.
4. Column-address is changed once each fast page cycle.
5. Enables on-chip refresh and address counters.

**AC CHARACTERISTICS**<sup>(1,2,3,4,5,6)</sup> (Recommended Operating Conditions unless otherwise noted.)

Symbol	Parameter	-35		-60		Units
		Min.	Max.	Min.	Max.	
t <sub>RC</sub>	Random READ or WRITE Cycle Time	60	—	110	—	ns
t <sub>RAC</sub>	Access Time from $\overline{\text{RAS}}$ <sup>(6, 7)</sup>	—	35	—	60	ns
t <sub>CAC</sub>	Access Time from $\overline{\text{CAS}}$ <sup>(6, 8, 15)</sup>	—	10	—	15	ns
t <sub>AA</sub>	Access Time from Column-Address <sup>(6)</sup>	—	18	—	30	ns
t <sub>RAS</sub>	$\overline{\text{RAS}}$ Pulse Width	35	10K	60	10K	ns
t <sub>RP</sub>	$\overline{\text{RAS}}$ Precharge Time	20	—	40	—	ns
t <sub>CAS</sub>	$\overline{\text{CAS}}$ Pulse Width <sup>(26)</sup>	6	10K	10	10K	ns
t <sub>CP</sub>	$\overline{\text{CAS}}$ Precharge Time <sup>(9, 25)</sup>	5	—	10	—	ns
t <sub>CSH</sub>	$\overline{\text{CAS}}$ Hold Time <sup>(21)</sup>	35	—	60	—	ns
t <sub>RCD</sub>	$\overline{\text{RAS}}$ to $\overline{\text{CAS}}$ Delay Time <sup>(10, 20)</sup>	11	28	20	45	ns
t <sub>ASR</sub>	Row-Address Setup Time	0	—	0	—	ns
t <sub>RAH</sub>	Row-Address Hold Time	6	—	10	—	ns
t <sub>ASC</sub>	Column-Address Setup Time <sup>(20)</sup>	0	—	0	—	ns
t <sub>CAH</sub>	Column-Address Hold Time <sup>(20)</sup>	6	—	10	—	ns
t <sub>AR</sub>	Column-Address Hold Time (referenced to $\overline{\text{RAS}}$ )	30	—	40	—	ns
t <sub>RAD</sub>	$\overline{\text{RAS}}$ to Column-Address Delay Time <sup>(11)</sup>	12	20	15	30	ns
t <sub>RAL</sub>	Column-Address to $\overline{\text{RAS}}$ Lead Time	18	—	30	—	ns
t <sub>RPC</sub>	$\overline{\text{RAS}}$ to $\overline{\text{CAS}}$ Precharge Time	0	—	0	—	ns
t <sub>RSH</sub>	$\overline{\text{RAS}}$ Hold Time <sup>(27)</sup>	8	—	15	—	ns
t <sub>CLZ</sub>	$\overline{\text{CAS}}$ to Output in Low-Z <sup>(15, 29)</sup>	3	—	3	—	ns
t <sub>CRP</sub>	$\overline{\text{CAS}}$ to $\overline{\text{RAS}}$ Precharge Time <sup>(21)</sup>	5	—	5	—	ns
t <sub>OD</sub>	Output Disable Time <sup>(19, 28, 29)</sup>	3	15	3	15	ns
t <sub>OE</sub>	Output Enable Time <sup>(15, 16)</sup>	—	10	—	15	ns
t <sub>OEHC</sub>	$\overline{\text{OE}}$ HIGH Hold Time from $\overline{\text{CAS}}$ HIGH	10	—	10	—	ns
t <sub>OEP</sub>	$\overline{\text{OE}}$ HIGH Pulse Width	10	—	10	—	ns
t <sub>OES</sub>	$\overline{\text{OE}}$ LOW to $\overline{\text{CAS}}$ HIGH Setup Time	5	—	5	—	ns
t <sub>RCS</sub>	Read Command Setup Time <sup>(17, 20)</sup>	0	—	0	—	ns
t <sub>RRH</sub>	Read Command Hold Time (referenced to $\overline{\text{RAS}}$ ) <sup>(12)</sup>	0	—	0	—	ns
t <sub>RCH</sub>	Read Command Hold Time (referenced to $\overline{\text{CAS}}$ ) <sup>(12, 17, 21)</sup>	0	—	0	—	ns
t <sub>WCH</sub>	Write Command Hold Time <sup>(17, 27)</sup>	5	—	10	—	ns
t <sub>WCR</sub>	Write Command Hold Time (referenced to $\overline{\text{RAS}}$ ) <sup>(17)</sup>	30	—	50	—	ns

(Continued)

**AC CHARACTERISTICS**<sup>(1,2,3,4,5,6)</sup> (Recommended Operating Conditions unless otherwise noted.)

Symbol	Parameter	-35		-60		Units
		Min.	Max.	Min.	Max.	
tWP	Write Command Pulse Width <sup>(17)</sup>	5	—	10	—	ns
tWPZ	$\overline{WE}$ Pulse Widths to Disable Outputs	10	—	10	—	ns
tRWL	Write Command to $\overline{RAS}$ Lead Time <sup>(17)</sup>	8	—	15	—	ns
tcWL	Write Command to $\overline{CAS}$ Lead Time <sup>(17, 21)</sup>	8	—	15	—	ns
twCS	Write Command Setup Time <sup>(14, 17, 20)</sup>	0	—	0	—	ns
tDHR	Data-in Hold Time (referenced to $\overline{RAS}$ )	30	—	40	—	ns
tACH	Column-Address Setup Time to $\overline{CAS}$ Precharge during WRITE Cycle	15	—	15	—	ns
toEH	$\overline{OE}$ Hold Time from $\overline{WE}$ during READ-MODIFY-WRITE cycle <sup>(18)</sup>	8	—	15	—	ns
tDS	Data-In Setup Time <sup>(15, 22)</sup>	0	—	0	—	ns
tDH	Data-In Hold Time <sup>(15, 22)</sup>	6	—	10	—	ns
tRWC	READ-MODIFY-WRITE Cycle Time	80	—	140	—	ns
tRWD	$\overline{RAS}$ to $\overline{WE}$ Delay Time during READ-MODIFY-WRITE Cycle <sup>(14)</sup>	45	—	80	—	ns
tcWD	$\overline{CAS}$ to $\overline{WE}$ Delay Time <sup>(14, 20)</sup>	25	—	36	—	ns
tAWD	Column-Address to $\overline{WE}$ Delay Time <sup>(14)</sup>	30	—	49	—	ns
tPC	Fast Page Mode READ or WRITE Cycle Time <sup>(24)</sup>	12	—	25	—	ns
tRASP	$\overline{RAS}$ Pulse Width	35	100K	60	100K	ns
tCPA	Access Time from $\overline{CAS}$ Precharge <sup>(15)</sup>	—	21	—	34	ns
tPRWC	READ-WRITE Cycle Time <sup>(24)</sup>	40	—	56	—	ns
tOFF	Output Buffer Turn-Off Delay from $\overline{CAS}$ or $\overline{RAS}$ <sup>(13,15,19, 29)</sup>	3	15	3	15	ns
tWHZ	Output Disable Delay from $\overline{WE}$	3	15	3	15	ns
tCLCH	Last $\overline{CAS}$ going LOW to First $\overline{CAS}$ returning HIGH <sup>(23)</sup>	10	—	10	—	ns
tCSR	$\overline{CAS}$ Setup Time (CBR REFRESH) <sup>(30, 20)</sup>	8	—	10	—	ns
tCHR	$\overline{CAS}$ Hold Time (CBR REFRESH) <sup>(30, 21)</sup>	8	—	10	—	ns
tORD	$\overline{OE}$ Setup Time prior to $\overline{RAS}$ during HIDDEN REFRESH Cycle	0	—	0	—	ns
tREF	Refresh Period (1024 Cycles)	—	16	—	16	ms
tr	Transition Time (Rise or Fall) <sup>(2, 3)</sup>	1	50	1	50	ns

**Notes:**

1. An initial pause of 200  $\mu$ s is required after power-up followed by eight  $\overline{\text{RAS}}$  refresh cycle ( $\overline{\text{RAS}}$ -Only or CBR) before proper device operation is assured. The eight  $\overline{\text{RAS}}$  cycles wake-up should be repeated any time the  $t_{\text{REF}}$  refresh requirement is exceeded.
2.  $V_{\text{IH}}$  (MIN) and  $V_{\text{IL}}$  (MAX) are reference levels for measuring timing of input signals. Transition times, are measured between  $V_{\text{IH}}$  and  $V_{\text{IL}}$  (or between  $V_{\text{IL}}$  and  $V_{\text{IH}}$ ) and assume to be 1 ns for all inputs.
3. In addition to meeting the transition rate specification, all input signals must transit between  $V_{\text{IH}}$  and  $V_{\text{IL}}$  (or between  $V_{\text{IL}}$  and  $V_{\text{IH}}$ ) in a monotonic manner.
4. If  $\overline{\text{CAS}}$  and  $\overline{\text{RAS}} = V_{\text{IH}}$ , data output is High-Z.
5. If  $\overline{\text{CAS}} = V_{\text{IL}}$ , data output may contain data from the last valid READ cycle.
6. Measured with a load equivalent to one TTL gate and 50 pF.
7. Assumes that  $t_{\text{RCD}} - t_{\text{RCD}} (\text{MAX})$ . If  $t_{\text{RCD}}$  is greater than the maximum recommended value shown in this table,  $t_{\text{RAC}}$  will increase by the amount that  $t_{\text{RCD}}$  exceeds the value shown.
8. Assumes that  $t_{\text{RCD}} \bullet t_{\text{RCD}} (\text{MAX})$ .
9. If  $\overline{\text{CAS}}$  is LOW at the falling edge of  $\overline{\text{RAS}}$ , data out will be maintained from the previous cycle. To initiate a new cycle and clear the data output buffer,  $\overline{\text{CAS}}$  and  $\overline{\text{RAS}}$  must be pulsed for  $t_{\text{CP}}$ .
10. Operation with the  $t_{\text{RCD}} (\text{MAX})$  limit ensures that  $t_{\text{RAC}} (\text{MAX})$  can be met.  $t_{\text{RCD}} (\text{MAX})$  is specified as a reference point only; if  $t_{\text{RCD}}$  is greater than the specified  $t_{\text{RCD}} (\text{MAX})$  limit, access time is controlled exclusively by  $t_{\text{CAC}}$ .
11. Operation within the  $t_{\text{RAD}} (\text{MAX})$  limit ensures that  $t_{\text{RCD}} (\text{MAX})$  can be met.  $t_{\text{RAD}} (\text{MAX})$  is specified as a reference point only; if  $t_{\text{RAD}}$  is greater than the specified  $t_{\text{RAD}} (\text{MAX})$  limit, access time is controlled exclusively by  $t_{\text{AA}}$ .
12. Either  $t_{\text{RCH}}$  or  $t_{\text{RRH}}$  must be satisfied for a READ cycle.
13.  $t_{\text{OFF}} (\text{MAX})$  defines the time at which the output achieves the open circuit condition; it is not a reference to  $V_{\text{OH}}$  or  $V_{\text{OL}}$ .
14.  $t_{\text{WCS}}$ ,  $t_{\text{RWD}}$ ,  $t_{\text{AWD}}$  and  $t_{\text{CWD}}$  are restrictive operating parameters in LATE WRITE and READ-MODIFY-WRITE cycle only. If  $t_{\text{WCS}} \bullet t_{\text{WCS}} (\text{MIN})$ , the cycle is an EARLY WRITE cycle and the data output will remain open circuit throughout the entire cycle. If  $t_{\text{RWD}} \bullet t_{\text{RWD}} (\text{MIN})$ ,  $t_{\text{AWD}} \bullet t_{\text{AWD}} (\text{MIN})$  and  $t_{\text{CWD}} \bullet t_{\text{CWD}} (\text{MIN})$ , the cycle is a READ-WRITE cycle and the data output will contain data read from the selected cell. If neither of the above conditions is met, the state of I/O (at access time and until  $\overline{\text{CAS}}$  and  $\overline{\text{RAS}}$  or  $\overline{\text{OE}}$  go back to  $V_{\text{IH}}$ ) is indeterminate.  $\overline{\text{OE}}$  held HIGH and  $\overline{\text{WE}}$  taken LOW after  $\overline{\text{CAS}}$  goes LOW result in a LATE WRITE ( $\overline{\text{OE}}$ -controlled) cycle.
15. Output parameter (I/O) is referenced to corresponding  $\overline{\text{CAS}}$  input.
16. During a READ cycle, if  $\overline{\text{OE}}$  is LOW then taken HIGH before  $\overline{\text{CAS}}$  goes HIGH, I/O goes open. If  $\overline{\text{OE}}$  is tied permanently LOW, a LATE WRITE or READ-MODIFY-WRITE is not possible.
17. Write command is defined as  $\overline{\text{WE}}$  going low.
18. LATE WRITE and READ-MODIFY-WRITE cycles must have both  $t_{\text{OD}}$  and  $t_{\text{OEH}}$  met ( $\overline{\text{OE}}$  HIGH during WRITE cycle) in order to ensure that the output buffers will be open during the WRITE cycle. The I/Os will provide the previously written data if  $\overline{\text{CAS}}$  remains LOW and  $\overline{\text{OE}}$  is taken back to LOW after  $t_{\text{OEH}}$  is met.
19. The I/Os are in open during READ cycles once  $t_{\text{OD}}$  or  $t_{\text{OFF}}$  occur.
20. The first  $\chi\overline{\text{CAS}}$  edge to transition LOW.
21. The last  $\chi\overline{\text{CAS}}$  edge to transition HIGH.
22. These parameters are referenced to  $\overline{\text{CAS}}$  leading edge in EARLY WRITE cycles and  $\overline{\text{WE}}$  leading edge in LATE WRITE or READ-MODIFY-WRITE cycles.
23. Last falling  $\chi\overline{\text{CAS}}$  edge to first rising  $\chi\overline{\text{CAS}}$  edge.
24. Last rising  $\chi\overline{\text{CAS}}$  edge to next cycle's last rising  $\chi\overline{\text{CAS}}$  edge.
25. Last rising  $\chi\overline{\text{CAS}}$  edge to first falling  $\chi\overline{\text{CAS}}$  edge.
26. Each  $\chi\overline{\text{CAS}}$  must meet minimum pulse width.
27. Last  $\chi\overline{\text{CAS}}$  to go LOW.
28. I/Os controlled, regardless of  $\overline{\text{CAS}}$ .
29. The 3 ns minimum is a parameter guaranteed by design.
30. Enables on-chip refresh and address counters.



AC WAVEFORMS  
FAST-PAGE-MODE READ CYCLE

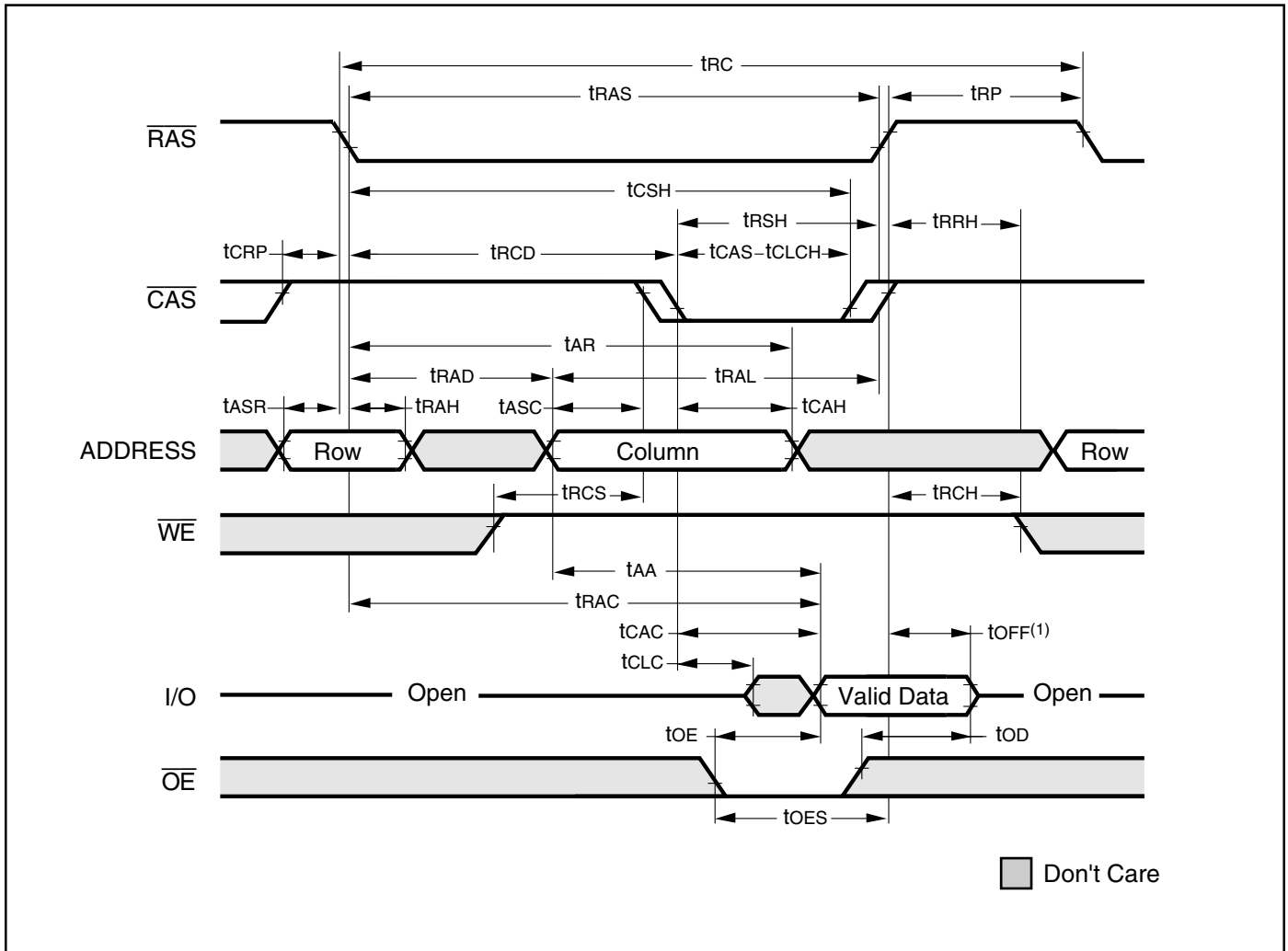

**Note:**  
1.  $t_{\text{OFF}}$  is referenced from rising edge of  $\overline{\text{CAS}}$ .

FAST PAGE MODE READ-MODIFY-WRITE CYCLE

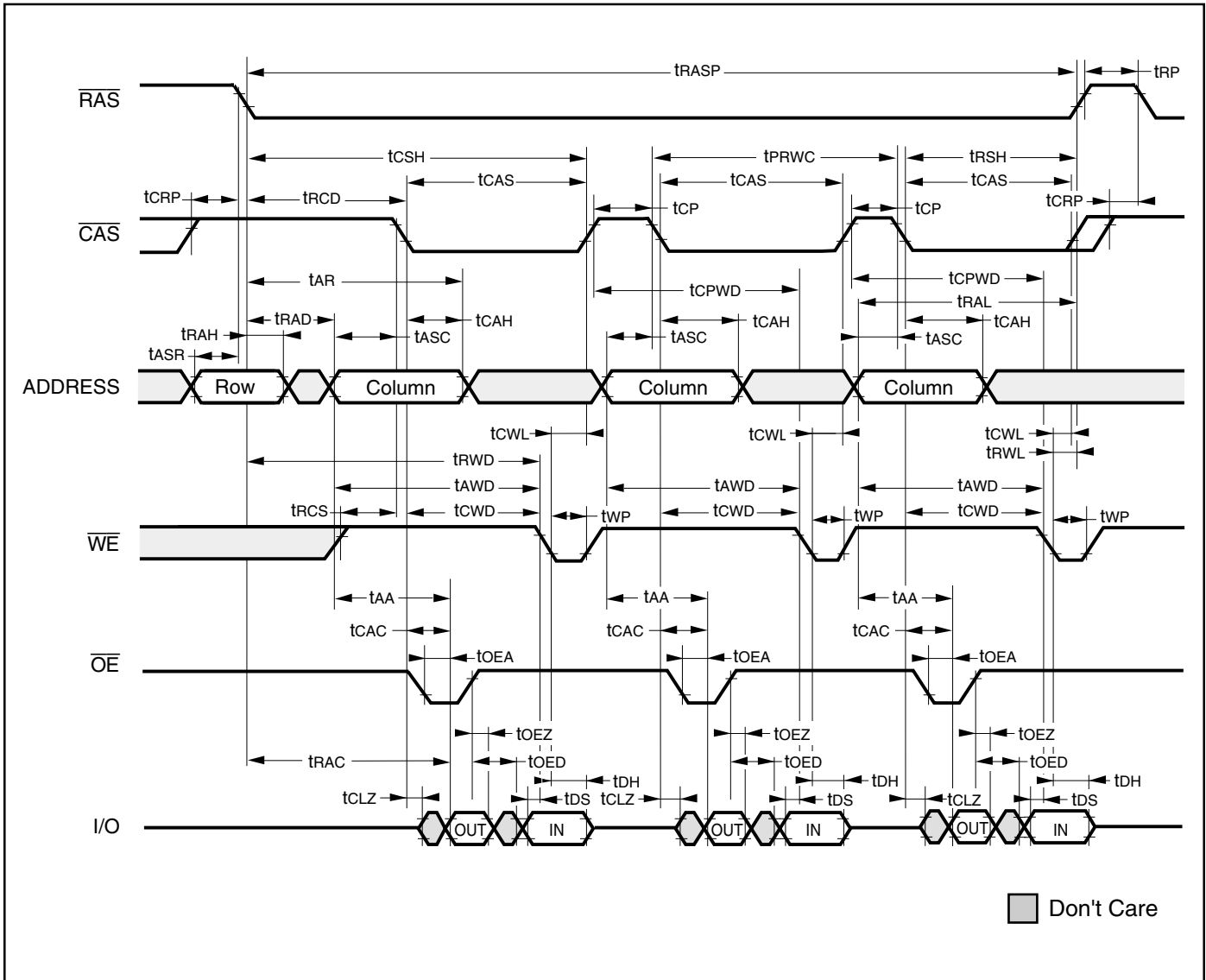

**FAST-PAGE-MODE EARLY WRITE CYCLE ( $\overline{OE}$  = DON'T CARE)**

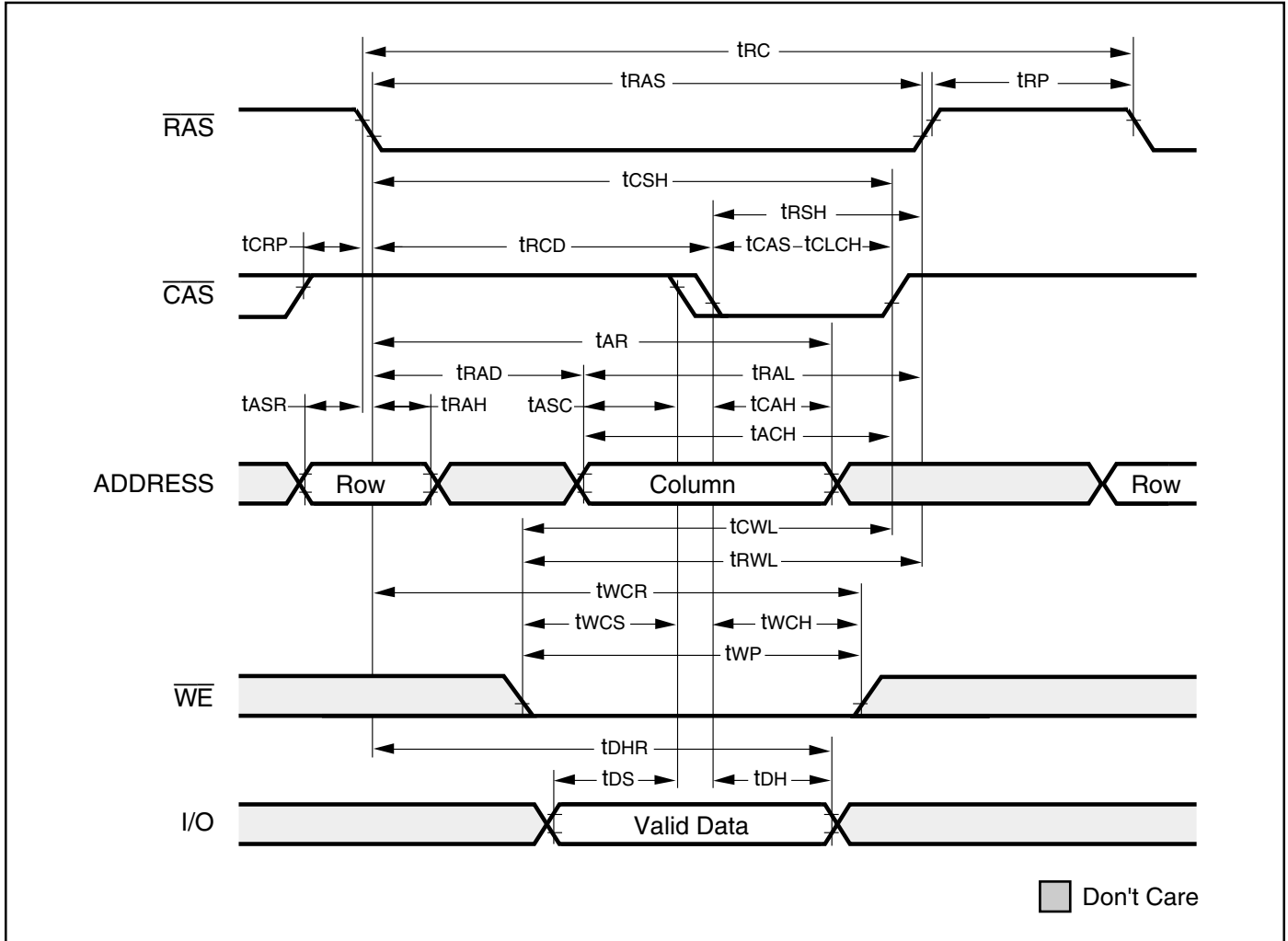

**FAST-PAGE-MODE READ WRITE CYCLE (LATE WRITE and READ-MODIFY-WRITE Cycles)**

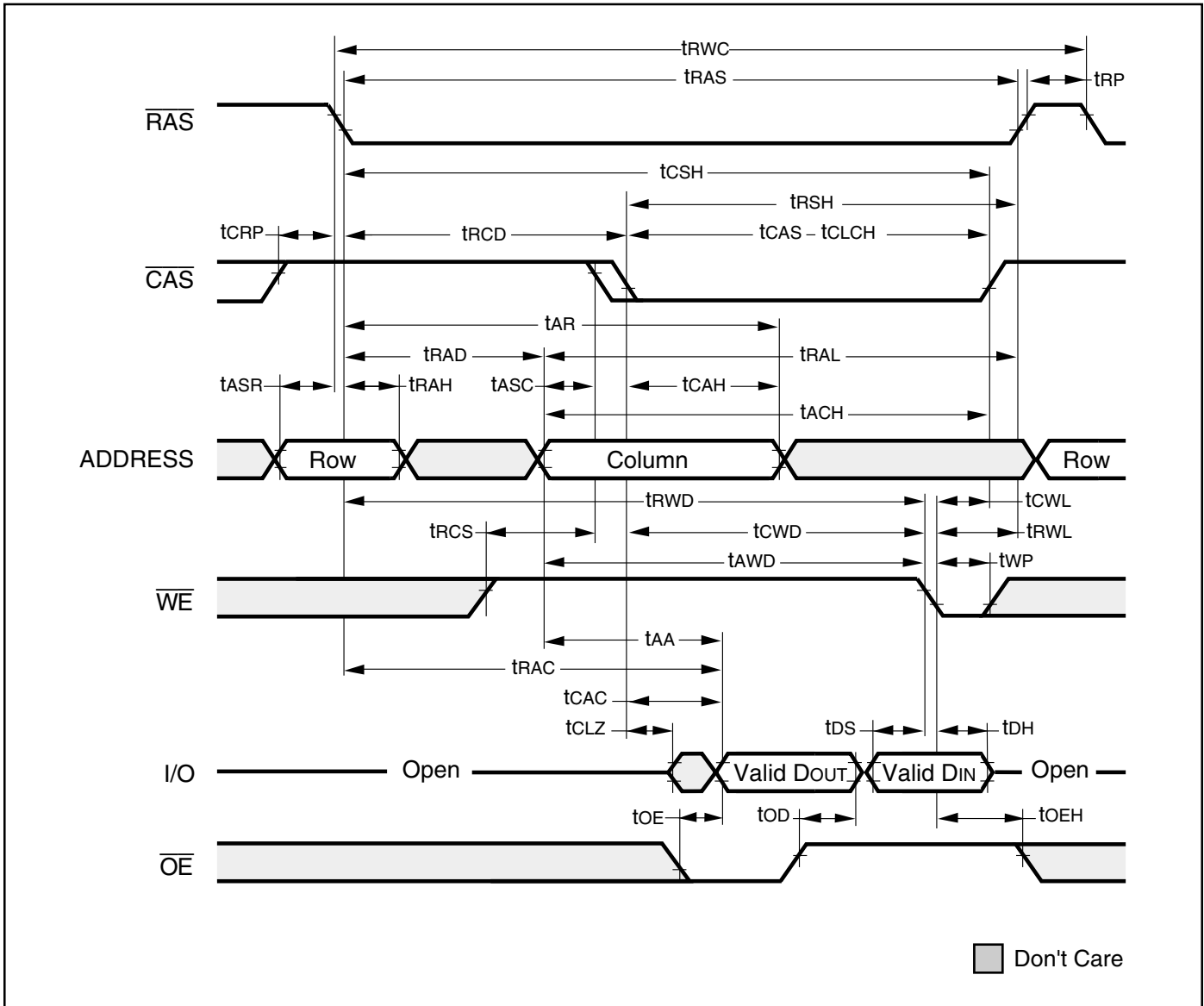

FAST PAGE MODE EARLY WRITE CYCLE

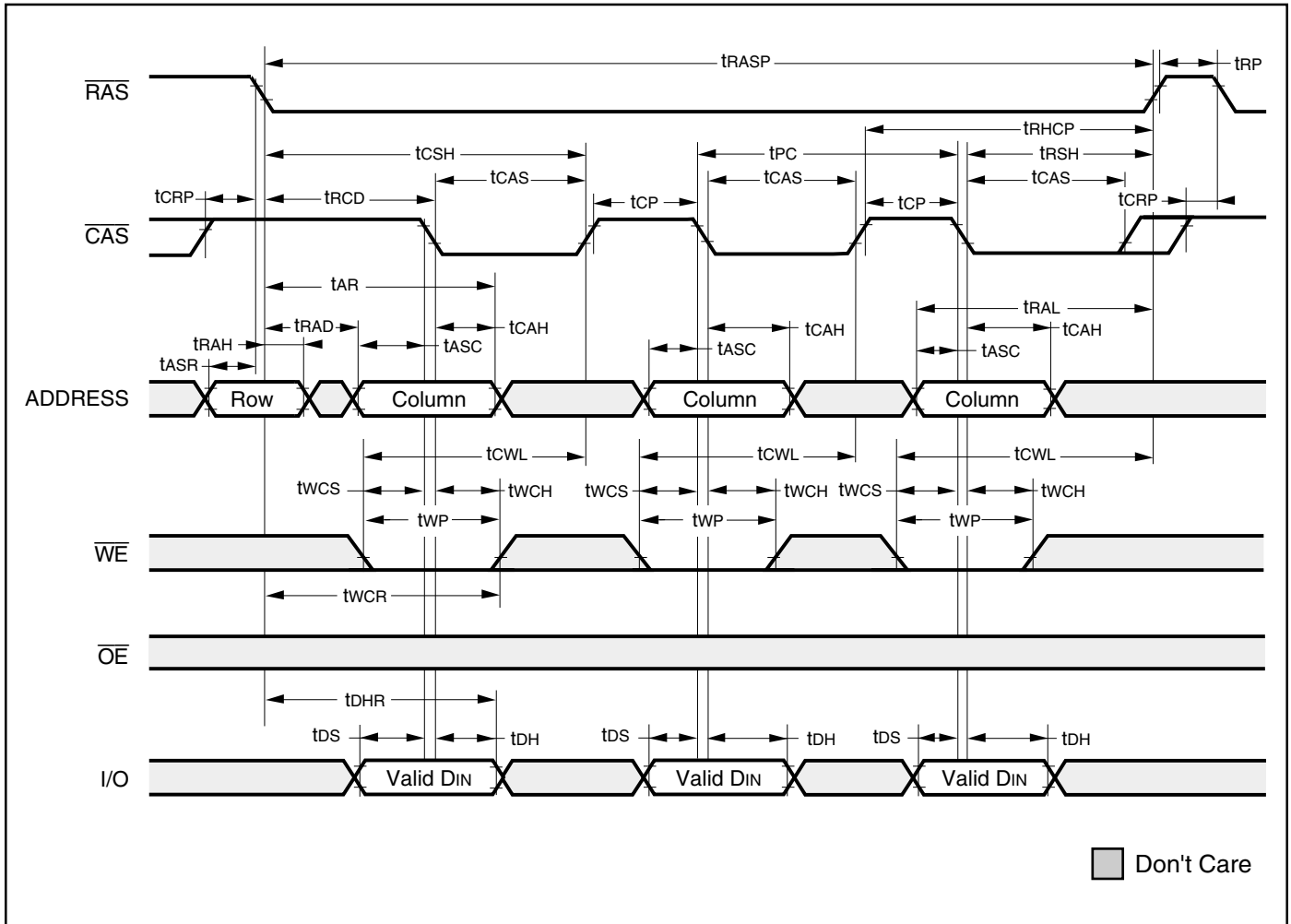

**READ CYCLE** (With  $\overline{WE}$ -Controlled Disable)

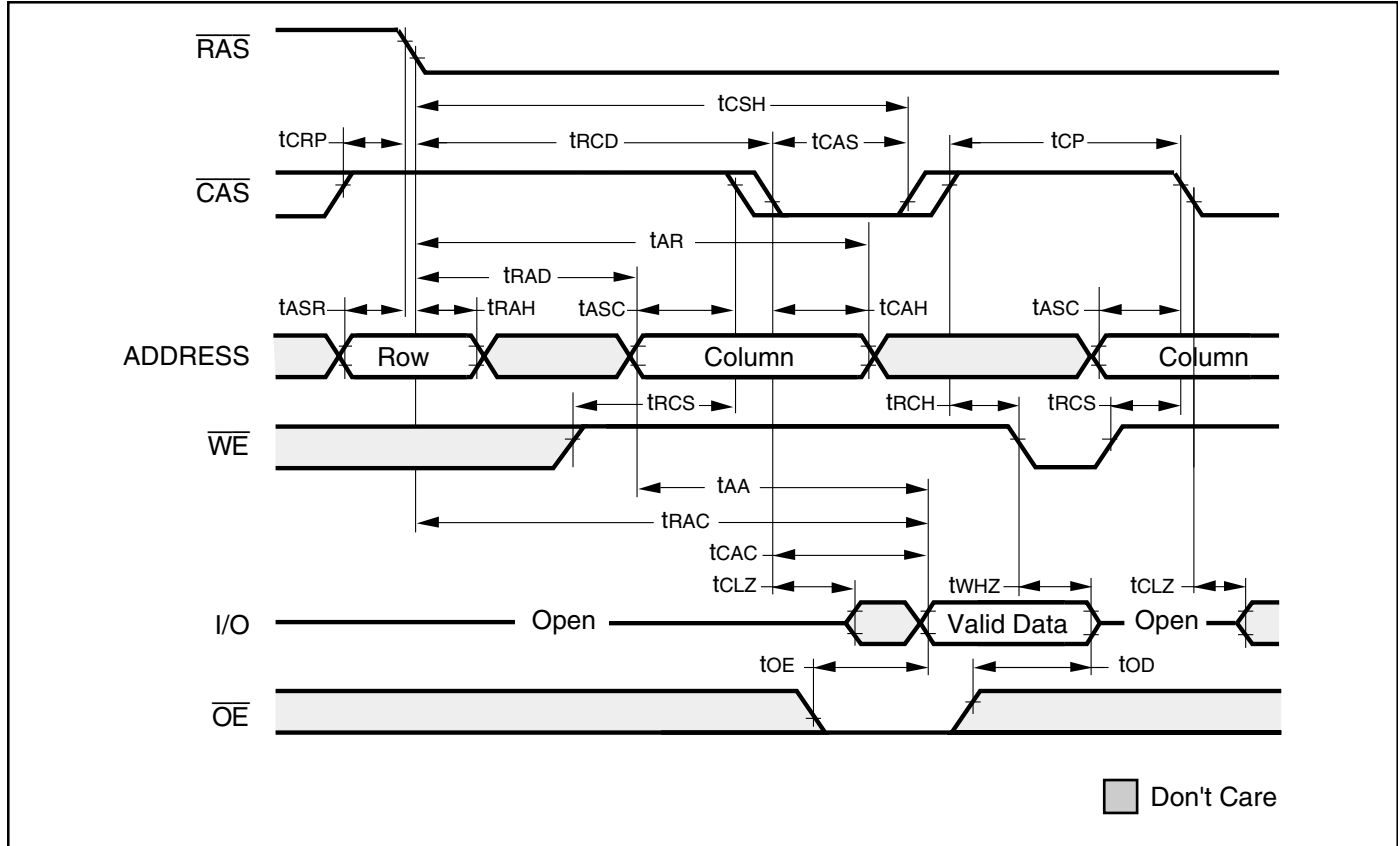

**$\overline{RAS}$ -ONLY REFRESH CYCLE** ( $\overline{OE}$ ,  $\overline{WE}$  = DON'T CARE)

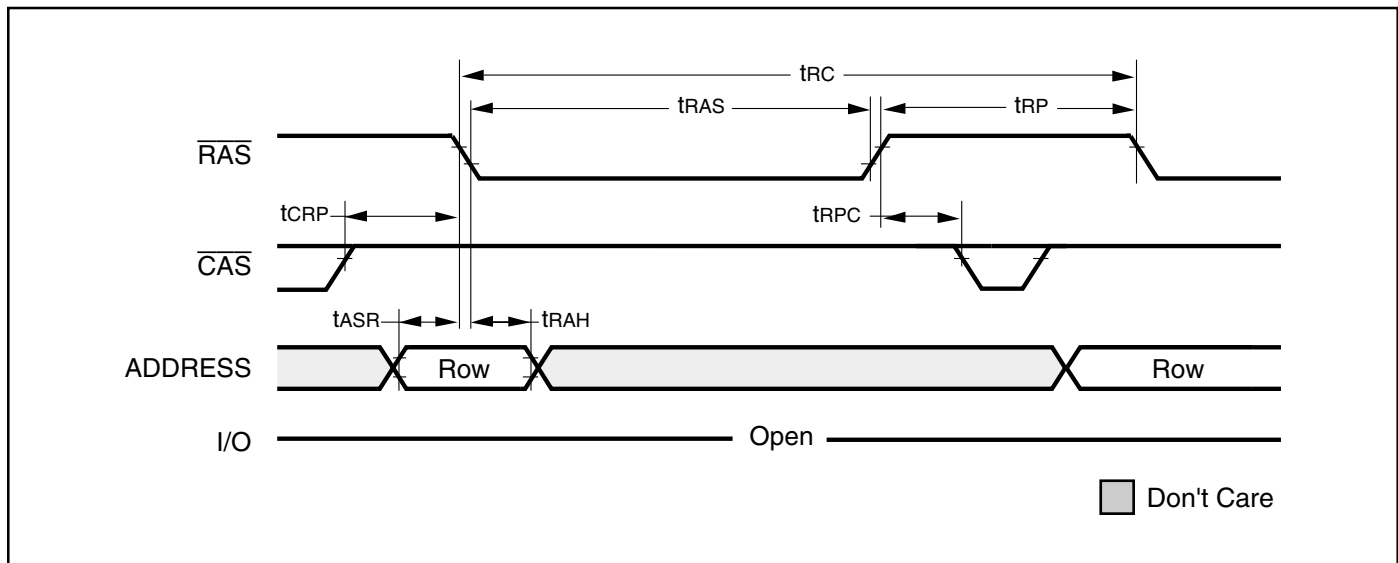

**$\overline{\text{CBR}}$  REFRESH CYCLE** (Addresses;  $\overline{\text{WE}}$ ,  $\overline{\text{OE}}$  = DON'T CARE)

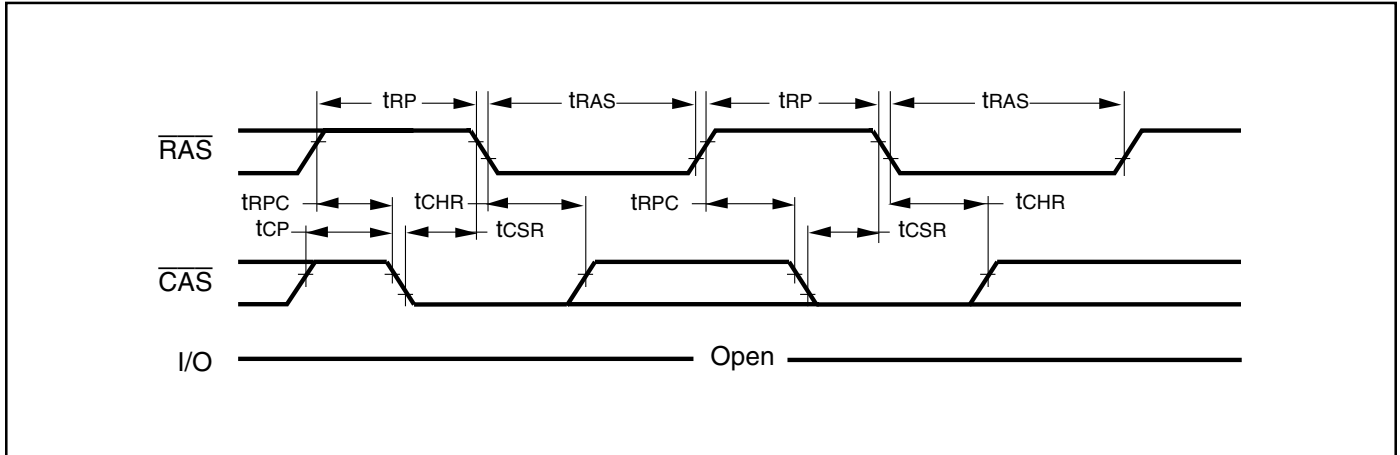

**HIDDEN REFRESH CYCLE<sup>(1)</sup>** ( $\overline{\text{WE}}$  = HIGH;  $\overline{\text{OE}}$  = LOW)

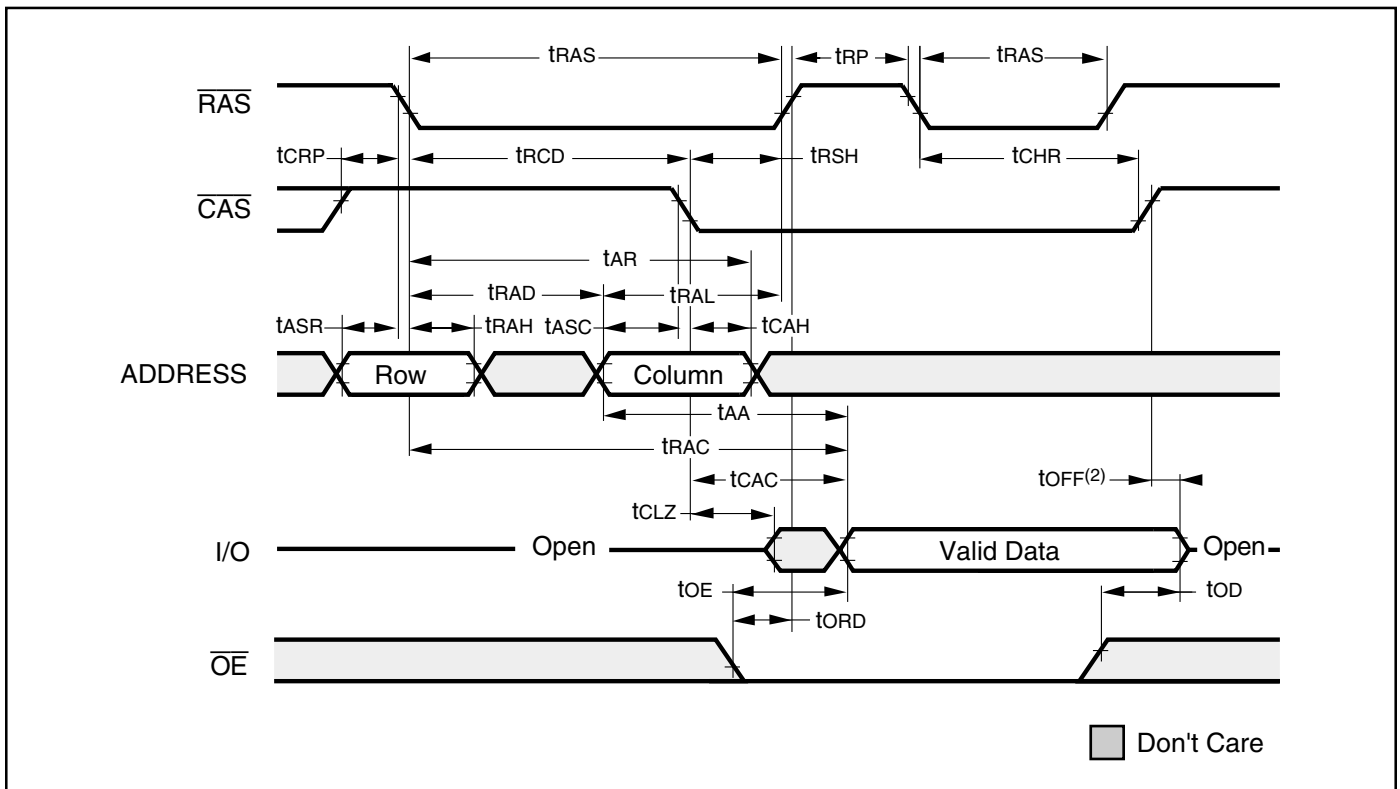

**Notes:**

1. A Hidden Refresh may also be performed after a Write Cycle. In this case,  $\overline{\text{WE}}$  = LOW and  $\overline{\text{OE}}$  = HIGH.
2.  $t_{\text{OFF}}$  is referenced from rising edge of RAS or CAS, whichever occurs last.

**ORDERING INFORMATION**

**IS41C85125**

**Commercial Range: 0·C to 70·C**

Speed (ns)	Order Part No.	Package
35	IS41C85125-35K	28-pin, 400-mil SOJ
60	IS41C85125-60K	28-pin, 400-mil SOJ

**Industrial Range: -40·C to 85·C**

Speed (ns)	Order Part No.	Package
35	IS41C85125-35KI	28-pin, 400-mil SOJ
60	IS41C85125-60KI	28-pin, 400-mil SOJ

**IS41LV85125**

**Commercial Range: 0·C to 70·C**

Speed (ns)	Order Part No.	Package
35	IS41LV85125-35K	28-pin, 400-mil SOJ
60	IS41LV85125-60K	28-pin, 400-mil SOJ

**Industrial Range: -40·C to 85·C**

Speed (ns)	Order Part No.	Package
60	IS41LV85125-60KI	28-pin, 400-mil SOJ



***Integrated Silicon Solution, Inc.***

2231 Lawson Lane  
Santa Clara, CA 95054  
Tel: 1-800-379-4774  
Fax: (408) 588-0806  
E-mail: sales@issi.com  
**www.issi.com**