

# IS61LV6416

## 64K x 16 HIGH-SPEED CMOS STATIC RAM WITH 3.3V SUPPLY

### FEATURES

- High-speed access time: 8, 10, 12, and 15 ns
- CMOS low power operation
  - 250 mW (typical) operating
  - 250  $\mu$ W (typical) standby
- TTL compatible interface levels
- Single 3.3V power supply
- Fully static operation: no clock or refresh required
- Three state outputs
- Data control for upper and lower bytes
- Industrial temperature available

### DESCRIPTION

The *ICSI* IS61LV6416 is a high-speed, 1,048,576-bit static RAM organized as 65,536 words by 16 bits. It is fabricated using *ICSI's* high-performance CMOS technology. This highly reliable process coupled with innovative circuit design techniques, yields access times as fast as 8 ns with low power consumption.

When  $\overline{CE}$  is HIGH (deselected), the device assumes a standby mode at which the power dissipation can be reduced down with CMOS input levels.

Easy memory expansion is provided by using Chip Enable and Output Enable inputs,  $\overline{CE}$  and  $\overline{OE}$ . The active LOW Write Enable ( $\overline{WE}$ ) controls both writing and reading of the memory. A data byte allows Upper Byte ( $\overline{UB}$ ) and Lower Byte ( $\overline{LB}$ ) access.

The IS61LV6416 is packaged in the JEDEC standard 44-pin 400mil SOJ, 44-pin 400mil TSOP-2, and 48-pin 6\*8mm TF-BGA.

### FUNCTIONAL BLOCK DIAGRAM

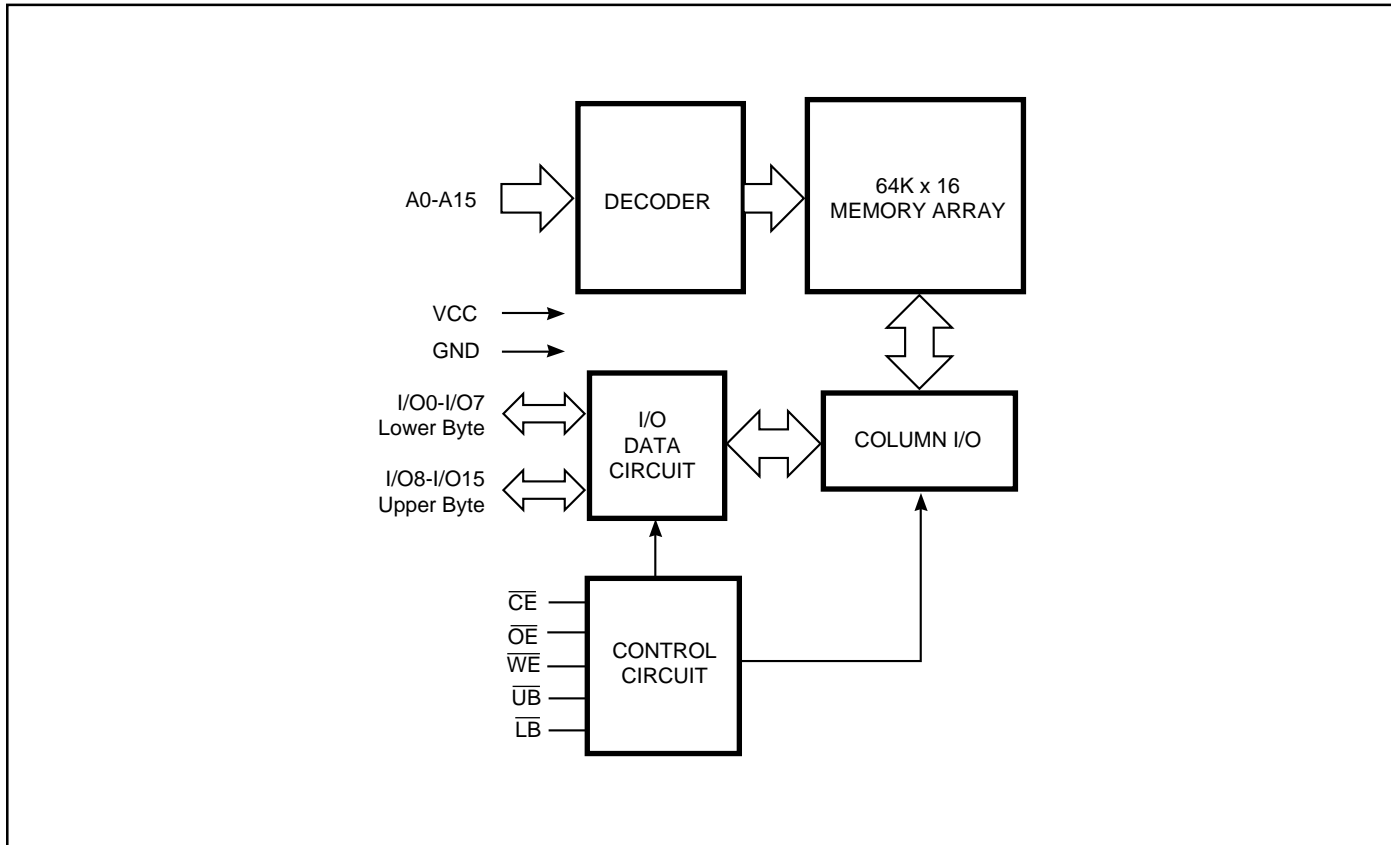

ICSI reserves the right to make changes to its products at any time without notice in order to improve design and supply the best possible product. We assume no responsibility for any errors which may appear in this publication. © Copyright 2000, Integrated Circuit Solution Inc.

PIN CONFIGURATIONS

44-Pin SOJ

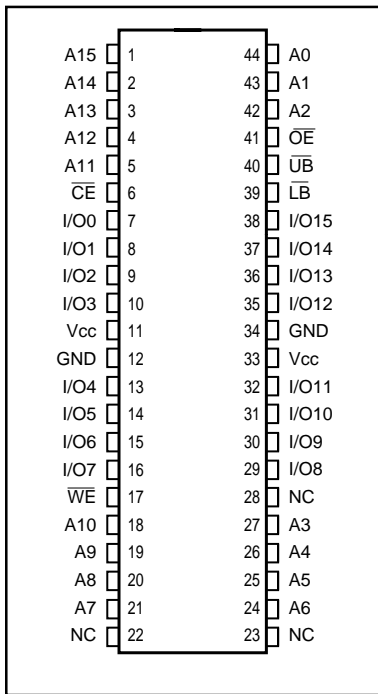

44-Pin TSOP-2

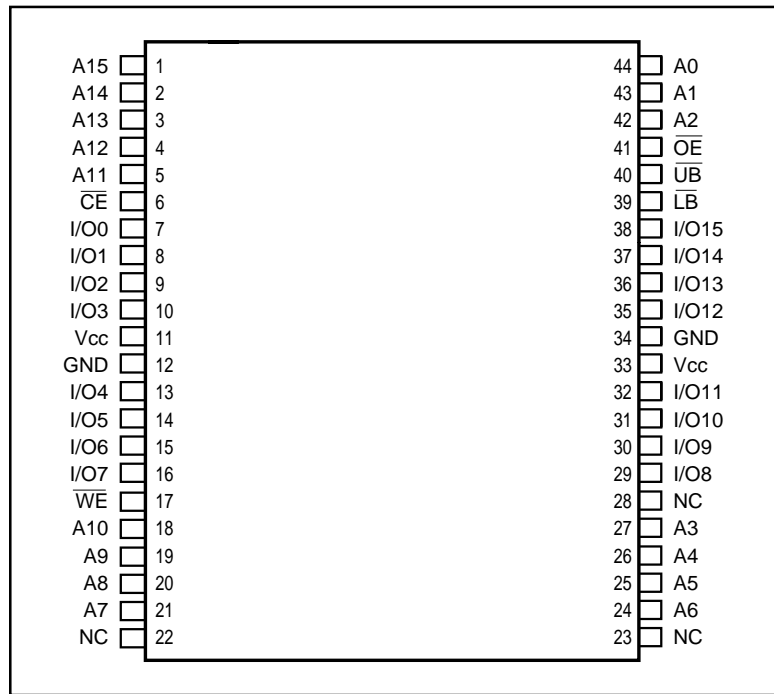

48-Pin 6x8mm TF-BGA

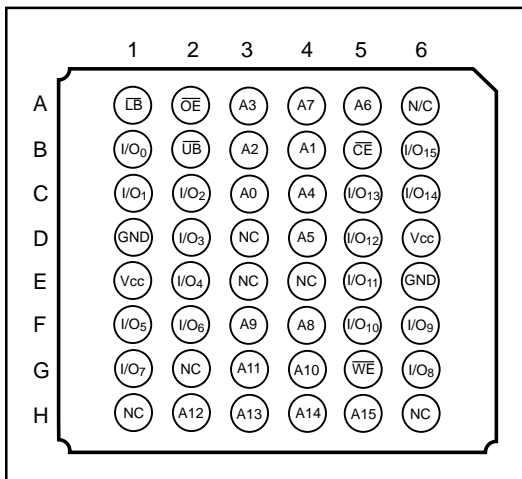

PIN DESCRIPTIONS

A0-A15	Address Inputs
I/O0-I/O15	Data Inputs/Outputs
CE	Chip Enable Input
OE	Output Enable Input
WE	Write Enable Input
LB	Lower-byte Control (I/O0-I/O7)
UB	Upper-byte Control (I/O8-I/O15)
NC	No Connection
Vcc	Power
GND	Ground

TRUTH TABLE

Mode	WE	CE	OE	LB	UB	I/O PIN		Vcc Current
						I/O0-I/O7	I/O8-I/O15	
Not Selected	X	H	X	X	X	High-Z	High-Z	ISB1, ISB2
Output Disabled	H	L	H	X	X	High-Z	High-Z	Icc
	X	L	X	H	H	High-Z	High-Z	
Read	H	L	L	L	H	DOUT	High-Z	Icc
	H	L	L	H	L	High-Z	DOUT	
	H	L	L	L	L	DOUT	DOUT	
Write	L	L	X	L	H	DIN	High-Z	Icc
	L	L	X	H	L	High-Z	DIN	
	L	L	X	L	L	DIN	DIN	

ABSOLUTE MAXIMUM RATINGS<sup>(1)</sup>

Symbol	Parameter	Value	Unit
V <sub>TERM</sub>	Terminal Voltage with Respect to GND	-0.5 to V <sub>CC</sub> +0.5	V
T <sub>STG</sub>	Storage Temperature	-65 to +150	°C
P <sub>T</sub>	Power Dissipation	1.5	W
I <sub>OUT</sub>	DC Output Current (LOW)	20	mA

Note:

1. Stress greater than those listed under ABSOLUTE MAXIMUM RATINGS may cause permanent damage to the device. This is a stress rating only and functional operation of the device at these or any other conditions above those indicated in the operational sections of this specification is not implied. Exposure to absolute maximum rating conditions for extended periods may affect reliability.

## OPERATING RANGE

Range	Ambient Temperature	V <sub>CC</sub>
Commercial	0°C to +70°C	3.3V ± 10%
Industrial	-40°C to +85°C	3.3V ± 10%

## DC ELECTRICAL CHARACTERISTICS (Over Operating Range)

Symbol	Parameter	Test Conditions	Min.	Max.	Unit	
V <sub>OH</sub>	Output HIGH Voltage	V <sub>CC</sub> = Min., I <sub>OH</sub> = -4.0 mA	2.4	—	V	
V <sub>OL</sub>	Output LOW Voltage	V <sub>CC</sub> = Min., I <sub>OL</sub> = 8.0 mA	—	0.4	V	
V <sub>IH</sub>	Input HIGH Voltage		2	V <sub>CC</sub> + 0.3	V	
V <sub>IL</sub>	Input LOW Voltage <sup>(1)</sup>		-0.3	0.8	V	
I <sub>LI</sub>	Input Leakage	GND ≤ V <sub>IN</sub> ≤ V <sub>CC</sub>	Com. Ind.	-2 5	2 5	μA
I <sub>LO</sub>	Output Leakage	GND ≤ V <sub>OUT</sub> ≤ V <sub>CC</sub> , Outputs Disabled	Com. Ind.	-2 -5	2 5	μA

Notes:

1. V<sub>IL</sub> (min.) = -2.0V for pulse width less than 10 ns.
2. The V<sub>CC</sub> operating range for 8 ns is 3.3V +10%, -5%.

POWER SUPPLY CHARACTERISTICS<sup>(1)</sup> (Over Operating Range)

Symbol	Parameter	Test Conditions	Com.	-8 ns		-10 ns		-12 ns		-15 ns		Unit
				Min.	Max.	Min.	Max.	Min.	Max.	Min.	Max.	
I <sub>CC</sub>	V <sub>CC</sub> Dynamic Operating Supply Current	V <sub>CC</sub> = Max., I <sub>OUT</sub> = 0 mA, f = f <sub>MAX</sub>	Com.	—	220	—	200	—	180	—	180	mA
			Ind.	—	230	—	210	—	190	—	190	
I <sub>SB1</sub>	TTL Standby Current (TTL Inputs)	V <sub>CC</sub> = Max., V <sub>IN</sub> = V <sub>IH</sub> or V <sub>IL</sub> CE ≥ V <sub>IH</sub> , f = 0	Com.	—	30	—	30	—	30	—	30	mA
			Ind.	—	40	—	40	—	40	—	40	
I <sub>SB2</sub>	CMOS Standby Current (CMOS Inputs)	V <sub>CC</sub> = Max., CE ≥ V <sub>CC</sub> - 0.2V, V <sub>IN</sub> ≥ V <sub>CC</sub> - 0.2V, or V <sub>IN</sub> ≤ 0.2V, f = 0	Com.	—	10	—	10	—	10	—	10	mA
			Ind.	—	15	—	15	—	15	—	15	

Note:

1. At f = f<sub>MAX</sub>, address and data inputs are cycling at the maximum frequency, f = 0 means no input lines change.

CAPACITANCE<sup>(1)</sup>

Symbol	Parameter	Conditions	Max.	Unit
C <sub>IN</sub>	Input Capacitance	V <sub>IN</sub> = 0V	6	pF
C <sub>OUT</sub>	Input/Output Capacitance	V <sub>OUT</sub> = 0V	8	pF

Note:

1. Tested initially and after any design or process changes that may affect these parameters.

READ CYCLE SWITCHING CHARACTERISTICS<sup>(1)</sup> (Over Operating Range)

Symbol	Parameter	-8		-10		-12		-15		Unit
		Min.	Max.	Min.	Max.	Min.	Max.	Min.	Max.	
t <sub>RC</sub>	Read Cycle Time	8	—	10	—	12	—	15	—	ns
t <sub>AA</sub>	Address Access Time	—	8	—	10	—	12	—	15	ns
t <sub>OHA</sub>	Output Hold Time	3	—	3	—	3	—	3	—	ns
t <sub>ACE</sub>	$\overline{CE}$ Access Time	—	8	—	10	—	12	—	15	ns
t <sub>DOE</sub>	$\overline{OE}$ Access Time	—	4	—	5	—	6	—	7	ns
t <sub>HZOE</sub> <sup>(2)</sup>	$\overline{OE}$ to High-Z Output	0	4	—	5	—	6	0	6	ns
t <sub>LZOE</sub> <sup>(2)</sup>	$\overline{OE}$ to Low-Z Output	0	—	0	—	0	—	0	—	ns
t <sub>HZCE</sub> <sup>(2)</sup>	$\overline{CE}$ to High-Z Output	0	4	0	5	0	6	0	6	ns
t <sub>LZCE</sub> <sup>(2)</sup>	$\overline{CE}$ to Low-Z Output	3	—	3	—	3	—	3	—	ns
t <sub>BA</sub>	$\overline{LB}$ , $\overline{UB}$ Access Time	—	4	—	5	—	6	—	7	ns
t <sub>HZB</sub>	$\overline{LB}$ , $\overline{UB}$ to High-Z Output	0	4	0	5	0	6	0	6	ns
t <sub>LZB</sub>	$\overline{LB}$ , $\overline{UB}$ to Low-Z Output	0	—	0	—	0	—	0	—	ns

Notes:

1. Test conditions assume signal transition times of 3 ns or less, timing reference levels of 1.5V, input pulse levels of 0 to 3.0V and output loading specified in Figure 1a.
2. Tested with the load in Figure 1b. Transition is measured  $\pm 500$  mV from steady-state voltage. Not 100% tested.
3. Not 100% tested.

## AC TEST CONDITIONS

Parameter	Unit
Input Pulse Level	0V to 3.0V
Input Rise and Fall Times	3 ns
Input and Output Timing and Reference Level	1.5V
Output Load	See Figures 1a and 1b

Notes:

1. The V<sub>cc</sub> operating range for 8 ns is 3.3V +10%, -5%.

## AC TEST LOADS

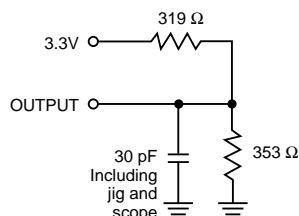

Figure 1a.

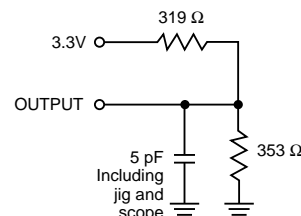
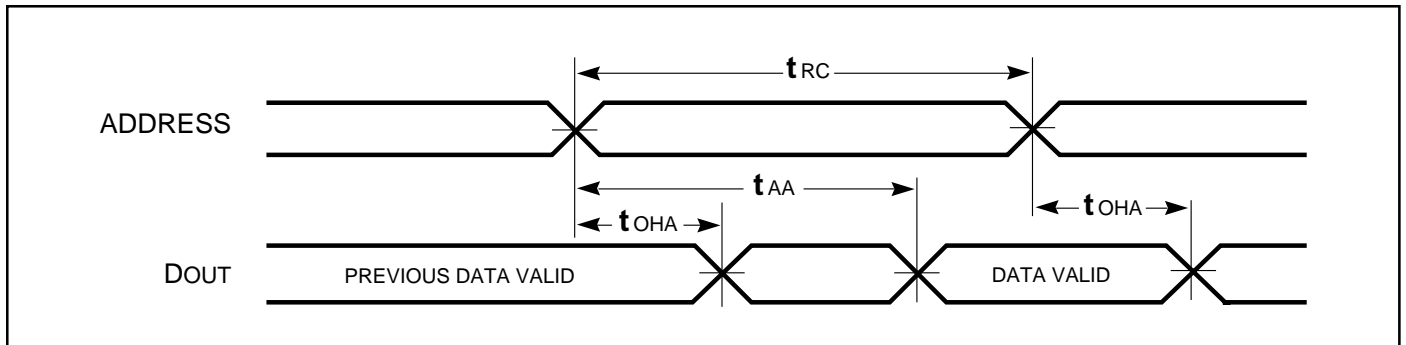

Figure 1b.

AC WAVEFORMS

READ CYCLE NO. 1<sup>(1,2)</sup> (Address Controlled) ( $\overline{CS} = \overline{OE} = V_{IL}$ ,  $\overline{UB}$  or  $\overline{LB} = V_{IL}$ )



READ CYCLE NO. 2<sup>(1,3)</sup>

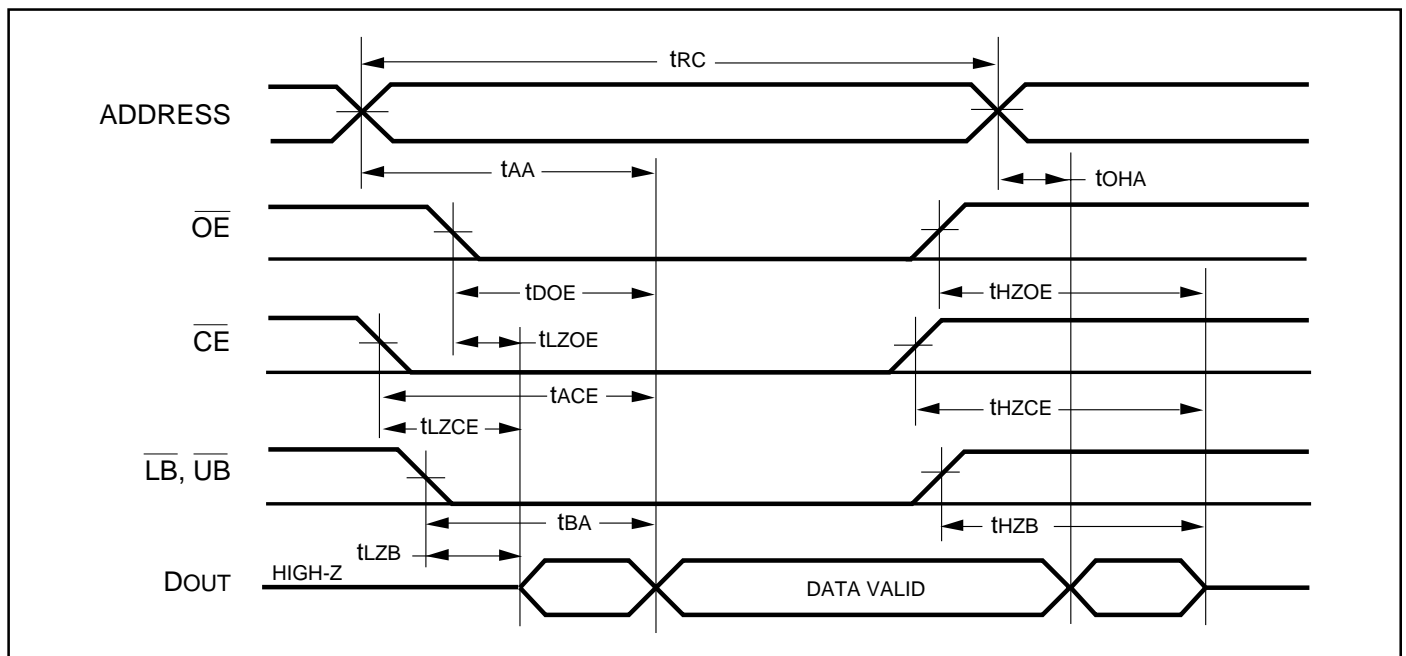

Notes:

1.  $\overline{WE}$  is HIGH for a Read Cycle.
2. The device is continuously selected.  $\overline{OE}$ ,  $\overline{CE}$ ,  $\overline{UB}$ , or  $\overline{LB} = V_{IL}$ .
3. Address is valid prior to or coincident with  $\overline{CE}$  LOW transition.

**WRITE CYCLE SWITCHING CHARACTERISTICS<sup>(1,3)</sup> (Over Operating Range)**

Symbol	Parameter	-8		-10		-12		-15		Unit
		Min.	Max.	Min.	Max.	Min.	Max.	Min.	Max.	
t <sub>WC</sub>	Write Cycle Time	8	—	10	—	12	—	15	—	ns
t <sub>SCE</sub>	$\overline{CE}$ to Write End	7	—	8	—	9	—	10	—	ns
t <sub>AW</sub>	Address Setup Time to Write End	7	—	8	—	9	—	10	—	ns
t <sub>HA</sub>	Address Hold from Write End	0	—	0	—	0	—	0	—	ns
t <sub>SA</sub>	Address Setup Time	0	—	0	—	0	—	0	—	ns
t <sub>PWB</sub>	$\overline{LB}$ , $\overline{UB}$ Valid to End of Write	7	—	8	—	9	—	10	—	ns
t <sub>PWE</sub>	$\overline{WE}$ Pulse Width	7	—	8	—	9	—	10	—	ns
t <sub>SD</sub>	Data Setup to Write End	4.5	—	5	—	6	—	7	—	ns
t <sub>HD</sub>	Data Hold from Write End	0	—	0	—	0	—	0	—	ns
t <sub>HZWE</sub> <sup>(2)</sup>	$\overline{WE}$ LOW to High-Z Output	—	4	—	5	—	6	—	7	ns
t <sub>LZWE</sub> <sup>(2)</sup>	$\overline{WE}$ HIGH to Low-Z Output	3	—	3	—	3	—	3	—	ns

**Notes:**

1. Test conditions assume signal transition times of 3 ns or less, timing reference levels of 1.5V, input pulse levels of 0 to 3.0V and output loading specified in Figure 1a.
2. Tested with the load in Figure 1b. Transition is measured  $\pm 500$  mV from steady-state voltage. Not 100% tested.
3. The internal write time is defined by the overlap of  $\overline{CE}$  LOW and  $\overline{UB}$  or  $\overline{LB}$ , and  $\overline{WE}$  LOW. All signals must be in valid states to initiate a Write, but any one can go inactive to terminate the Write. The Data Input Setup and Hold timing are referenced to the rising or falling edge of the signal that terminates the write.

AC WAVEFORMS

WRITE CYCLE NO. 1 ( $\overline{WE}$  Controlled)<sup>(1,2)</sup>

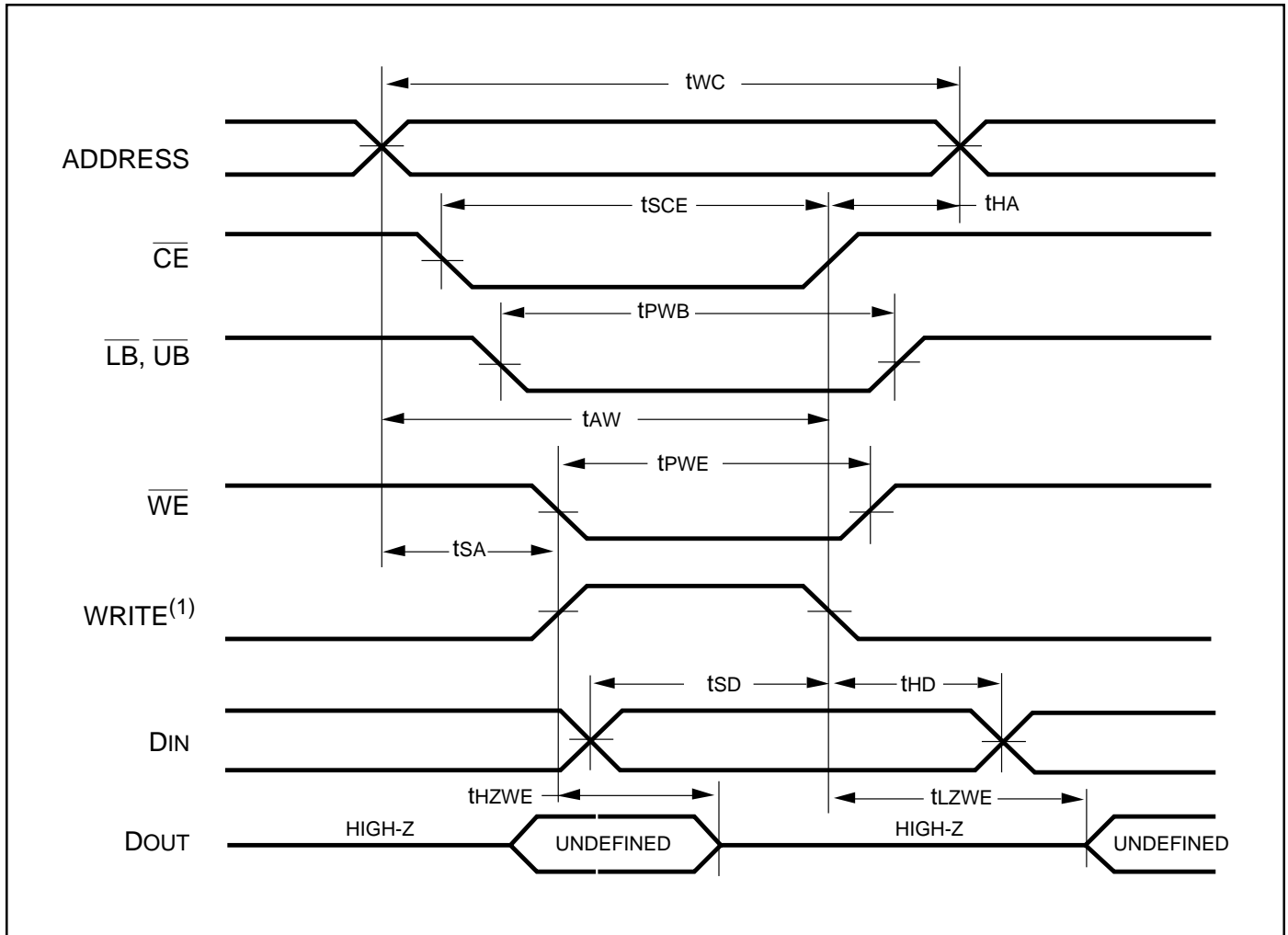

Notes:

1. WRITE is an internally generated signal asserted during an overlap of the LOW states on the  $\overline{CE}$  and  $\overline{WE}$  inputs and at least one of the  $\overline{LB}$  and  $\overline{UB}$  inputs being in the LOW state.
2.  $WRITE = (\overline{CE}) [ (\overline{LB}) = (\overline{UB}) ] (\overline{WE})$ .

## ORDERING INFORMATION

Commercial Range: 0°C to +70°C

Speed (ns)	Order Part No.	Package
8	IS61LV6416-8B	6*8mm TF-BGA
8	IS61LV6416-8T	400mil TSOP-2
8	IS61LV6416-8K	400mil SOJ
10	IS61LV6416-10B	6*8mm TF-BGA
10	IS61LV6416-10T	400mil TSOP-2
10	IS61LV6416-10K	400mil SOJ
12	IS61LV6416-12B	6*8mm TF-BGA
12	IS61LV6416-12T	400mil TSOP-2
12	IS61LV6416-12K	400mil SOJ
15	IS61LV6416-15B	6*8mm TF-BGA
15	IS61LV6416-15T	400mil TSOP-2
15	IS61LV6416-15K	400mil SOJ

## ORDERING INFORMATION

Industrial Range: -40°C to +85°C

Speed (ns)	Order Part No.	Package
8	IS61LV6416-8BI	6*8mm TF-BGA
8	IS61LV6416-8TI	400mil TSOP-2
8	IS61LV6416-8KI	400mil SOJ
10	IS61LV6416-10BI	6*8mm TF-BGA
10	IS61LV6416-10TI	400mil TSOP-2
10	IS61LV6416-10KI	400mil SOJ
12	IS61LV6416-12BI	6*8mm TF-BGA
12	IS61LV6416-12TI	400mil TSOP-2
12	IS61LV6416-12KI	400mil SOJ
15	IS61LV6416-15BI	6*8mm TF-BGA
15	IS61LV6416-15TI	400mil TSOP-2
15	IS61LV6416-15KI	400mil SOJ



*Integrated Circuit Solution Inc.*

HEADQUARTER:  
NO.2, TECHNOLOGY RD. V, SCIENCE-BASED INDUSTRIAL PARK,  
HSIN-CHU, TAIWAN, R.O.C.

TEL: 886-3-5780333

Fax: 886-3-5783000

BRANCH OFFICE:  
7F, NO. 106, SEC. 1, HSIN-TAI 5<sup>TH</sup> ROAD,  
HSICHIH TAIPEI COUNTY, TAIWAN, R.O.C.

TEL: 886-2-26962140

FAX: 886-2-26962252

<http://www.icsi.com.tw>