

## Before Getting Started

This document supplements the ISL55141, ISL55142, ISL55143 specification **FN6230**. Evaluation board users should review that document to obtain information on the part's basic functionality and power requirements. A most important note is **before powering up the board, review the Power-up Sequence in that specification**. There are many DC sources utilized, therefore a user may inadvertently mis-apply the power sources causing damage to the part.

Take time to review the ISL55141, ISL55142, ISL55143 Data Sheet (FN6230) and become familiar with the part's basic functions and power options. Note also that FN6230 supercedes this document with respect to updates and modifications. Always refer to that document if discrepancies occur.

No voltage should be greater than VCC or less than VEE. Also, VOH must be greater than VOL. Since there are so many variations of use, each evaluation board provides three jumpers relating to basic power strapping.

All ISL55141, ISL55142, ISL55143 boards are designed essentially in the same fashion. This document provides the user with the information regarding the evaluation board design, circuitry layout and jumper options.

## Jumper Options - VEE, VOL and GND

First, VEE can be negative with respect to ground for receiving negative input ranges on the VINPs (comparator Inputs). The comparator outputs QA, QB toggle between VOH and VOL. VOL could also be a negative voltage, although this is usually not the case. VOL should never be more negative than VEE.

For single supply operations, the user may wish to connect VEE to ground and VOL as well. Therefore, on each evaluation board there are positions for three jumpers (JP01, JP02, JP03).

*The user should make note that the ISL55141, ISL55142, ISL55143 all operate with VEE as the negative reference. There are no actual ground connection to the comparators unless VEE itself is connected to ground.*

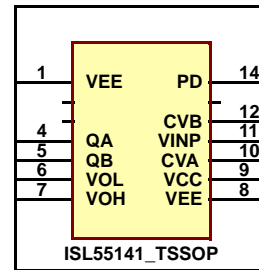

**FIGURE 1. THERE ARE NO GROUND PINS ON THESE COMPARATORS. VEE ALWAYS PROVIDES THE MOST NEGATIVE POWER CONNECTION.**

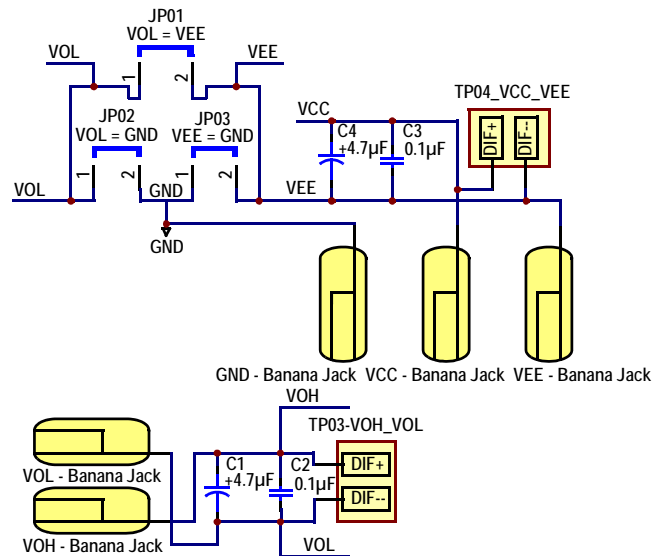

**FIGURE 2. THREE JUMPERS ARE AVAILABLE TO SET USER POWER STRAPPING OPTIONS.**

Before beginning the evaluation, the user should determine the desired relationship between GND, VEE and VOL.

### JP01 Connects VOL to VEE

*Both VEE and VOL voltage busses are negative with respect to ground. Comparator receives negative inputs and translates the QA/QB outputs with a negative low voltage.*

### JP02 Connects VOL to GND

*VOL low is connected to ground, VEE is negative with respect to ground. Comparator inputs operate below ground but QA/QB level translation in reference to ground.*

### JP03 Connects VEE to GND

*Both VOL and VEE are referenced to ground. There are no negative voltage requirements with respect to Comparator Inputs or level translation on the QA/QB Outputs*

### Scope Probe Connections

Another topic to cover before getting started is the evaluation board physical connections for waveform observations. On each schematic version you will see a component with pins designated as DIF+ and DIF-. This is not an active component but a dual pin header physically design to accommodate connection of active differential probes. This will minimize ground lead inductance and capacitive loading while make waveform observations. However, the user must also be mindful of max voltage limitations when using these types of probes. The ISL5514x comparators cover a large voltage range, so double check the probe's specifications.

#### SCOPE PROBE CONNECTIONS

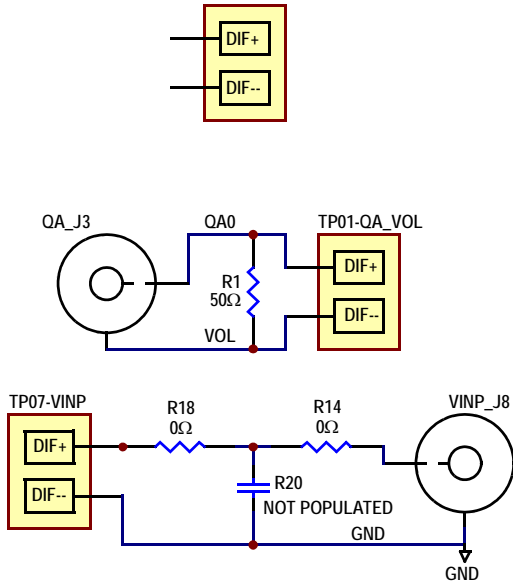

FIGURE 3. DUAL 1" SPACED PINS ARE PLACED ON THE EVALUATION BOARDS FOR DIFFERENTIAL PROBE CONNECTIONS

Scope probe test points (TP) are positioned across all inputs, outputs and VCC and VEE.

### BNC Connections

This series of evaluation boards also provides BNC connections for input and output signals. A key point to remember is the ISL55141, ISL55142, ISL55143 comparator outputs (QA/QB) operate with the VOH voltage as a High and VOL voltage as a Low. QA/QB BNC's, which are connected to the outputs, have the shield connected to the VOL voltage bus. Keep this in mind when making BNC connections to avoid connecting the GND shield of the BNC inputs to the VOL shield of the BNC outputs.

Also note that the comparator outputs have 50Ω terminations that you may need to remove for your application.

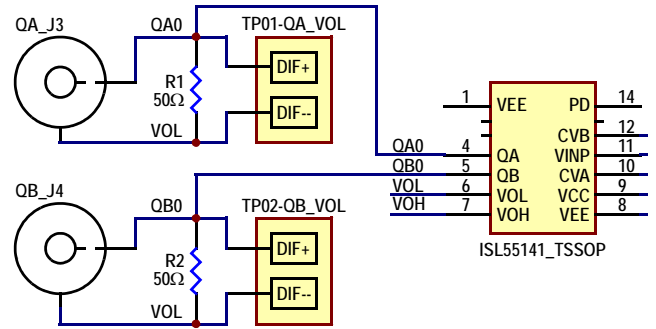

FIGURE 4. BNC CONNECTIONS ON THE QA/QB COMPARATOR OUTPUTS HAVE THE SHIELD CONNECTED TO THE VOL BUS. NOTE: YOU MAY WISH TO REMOVE THE 50Ω TERMINATIONS.

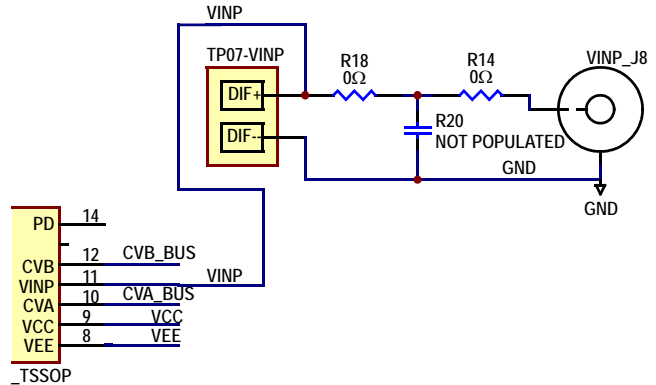

FIGURE 5. BNC CONNECTIONS ON THE HIGH SPEED VINP PINS HAVE THE SHIELD CONNECTED TO GND. NOTE: TWO SMD SERIES POSITIONS PLUS ONE POSITION TO GROUND ARE AVAILABLE FOR USER SPECIFIC CIRCUITRY.

### Power-Down Feature

All boards provide the same capability for testing the power-down feature. A SPDT-center OFF switch is provided for manual testing of the feature. In one position the PD input is connected to VCC (Power-down enabled). In the other position the PD Input is connected to VEE (power-down disabled).

#### S1 - POWER-DOWN CONTROL

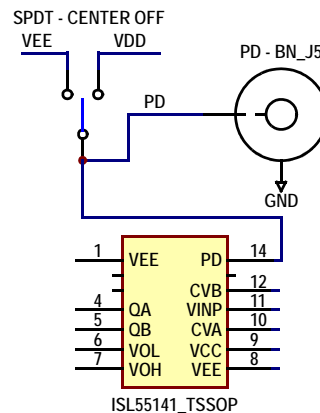

FIGURE 6. ALL ISL5514X EVALUATION BOARDS HAVE THE SAME POWER-DOWN CIRCUITRY.

Finally the center off position provides a means of connecting a repetitive signal source to the PD input. This is so the user can observe power-down enable/disable timing. An important note to remember when using the PD - BNC:

1. Place the switch in center-off position.
2. The PD input is referenced to VCC/VEE. The low amplitude of the PD input must match the VEE voltage. The high amplitude must be close to VCC.

### Comparator Threshold Rails

Each comparator has two thresholds. CVA/CVB. The data sheet explains the operation of these analog inputs. However, it should be mentioned that while the ISL55142 (Dual) and ISL55143 (QUAD) comparators have separate threshold inputs for each comparator, the evaluation boards have all CVA inputs tied to single CVA\_BUS. Accordingly, all CVB inputs are tied to a single CVB\_BUS.

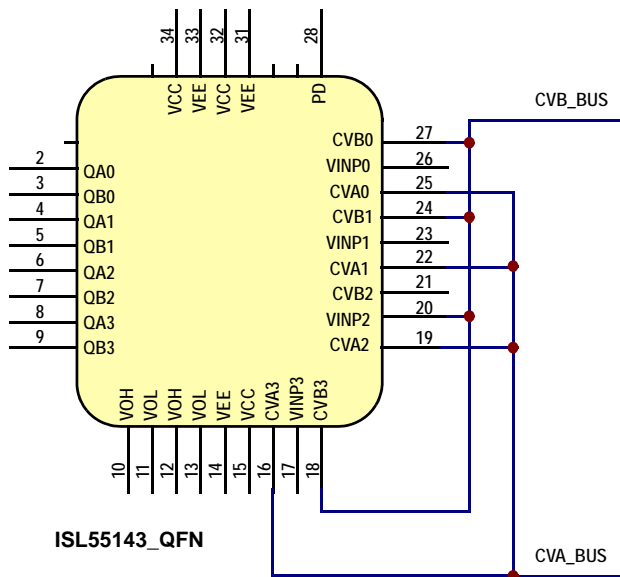

**FIGURE 7. ISL55142 AND ISL55143 COMPARATOR THRESHOLD CVA/CVB INPUTS ARE TIED TOGETHER TO EITHER THE CVA\_BUS OR CVB\_BUS.**

### Initial Power-Up

Please refer to the device specification for power-up sequencing and current requirements. Also note that the frequency of operation and number of comparators will determine the current needed. There are graphs in the specification regarding current characteristics.

When first powering up the device, set all power bus inputs to minimum current levels needed for quiescent operation. Check the device out statically with DC inputs on the VINP pins and observe that the QA/QB outputs toggle when the VINP voltage crosses the CVA and CVB thresholds.

Once static observations check out, you can then increase power current limits for VCC/VEE and VOH/VOL and apply higher frequency inputs to the VINP pins.

### Layout Information

All evaluation boards have complete silk-screen information regarding test points, jumpers and component placements. The silk-screen on the board you receive will provide up-to-date layout information.

### Schematic Information

Schematics are drawn with physical location in mind. Any changes in electrical circuitry will be updated in this document as needed.

Included in the following pages are three schematics. ISL55141 single comparator device, ISL55142 dual comparator and ISL55143 quad comparator device. The Evaluation boards are laid out for the TSSOP packages for the ISL55141 and ISL55142, while the ISL55143 is the QFN package. Please refer to the device specification for part numbers/options for these and other package ordering.

### Bill of Material

A bill of material of the ISL55142 evaluation board is included on page 6. It provides sources for special components such as the BNC connectors and banana jacks. All other parts are QPL standard passive components. Refer to device specification (FN6230) when ordering replacements for actual ISL55141, ISL55142 or ISL55143 devices.



# ISL55142IVZ Evaluation Board Schematic

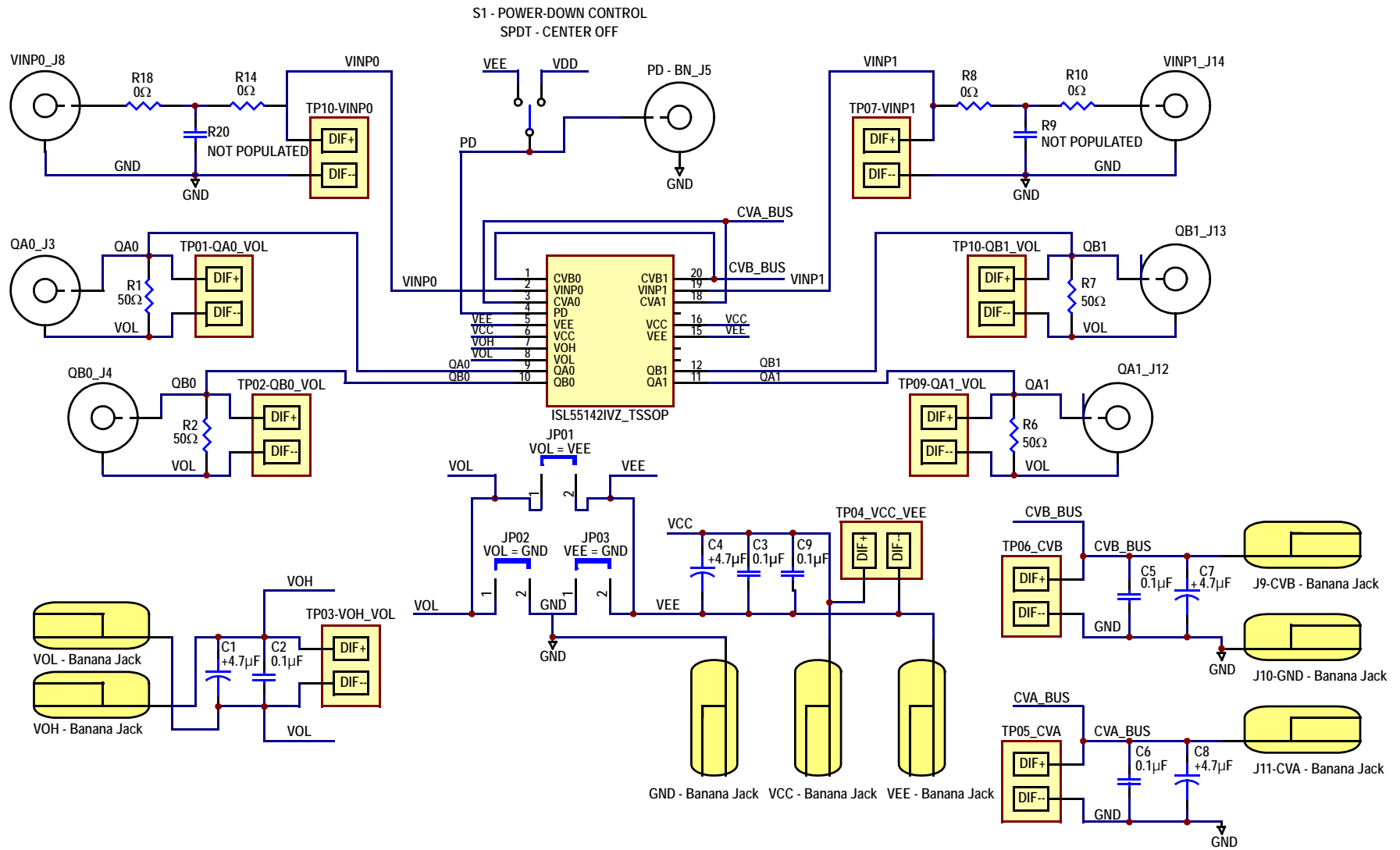

FIGURE 9. ISL55142IVZ TSSOP DUAL COMPARATOR EVALUATION BOARD

## Application Note 1270

### ISL5514x Bill of Materials

QTY	REF DES	DESCRIPTION	PART NUMBER	MANUFACTURER
7	J3-J5, J8, J12-J14	50Ω PCB mount receptacle	31-5329-52RFX	AMPHENOL
2	J7, J10	Right angle PCB mount insulated socket - single (black)	571-0100	DELTRON
1	J1	Right angle PCB mount insulated socket - single (blue)	571-0200	DELTRON
1	J20	Right angle PCB mount insulated socket - single (brown)	571-0300	DELTRON
1	J2	Right angle PCB mount insulated socket - single (green)	571-0400	DELTRON
1	J6	Right angle PCB mount insulated socket - single (red)	571-0500	DELTRON
1	J9	Right angle PCB mount insulated socket - single (white)	571-0600	DELTRON
1	J11	Right angle PCB mount insulated socket - single (yellow)	571-0700	DELTRON
2	C5, C6	Multilayer cap	C1608X7R1H104K	TDK
1	S1	Sealed subminiature toggle switch	ET03SD1CBE	ITT CANNON-C&K
3	C2, C3, C9	Multilayer cap	H1045-00104-25V10	GENERIC
4	C1, C4, C7, C8	Multilayer cap	H1065-004R7-50VR25	GENERIC
4	R3, R5, R8, R10	Thick film chip resistor	H2511-00R00-1/16W1	GENERIC
4	R1, R2, R6, R7	Thick film chip resistor	H2513-049R9-1/8W1	GENERIC
2	R4, R9	Thick film chip resistor (do not populate)	H2513-DNP-DNP-1	GENERIC
1	U1	High-speed CMOS window comparators (Pb-free)	ISL55142ARZ	INTERSIL
13	JP01-JP03, TP01-TP010	Two-pin jumper	JUMPER2_100	GENERIC

ISL55143IRZ Evaluation Board Schematic

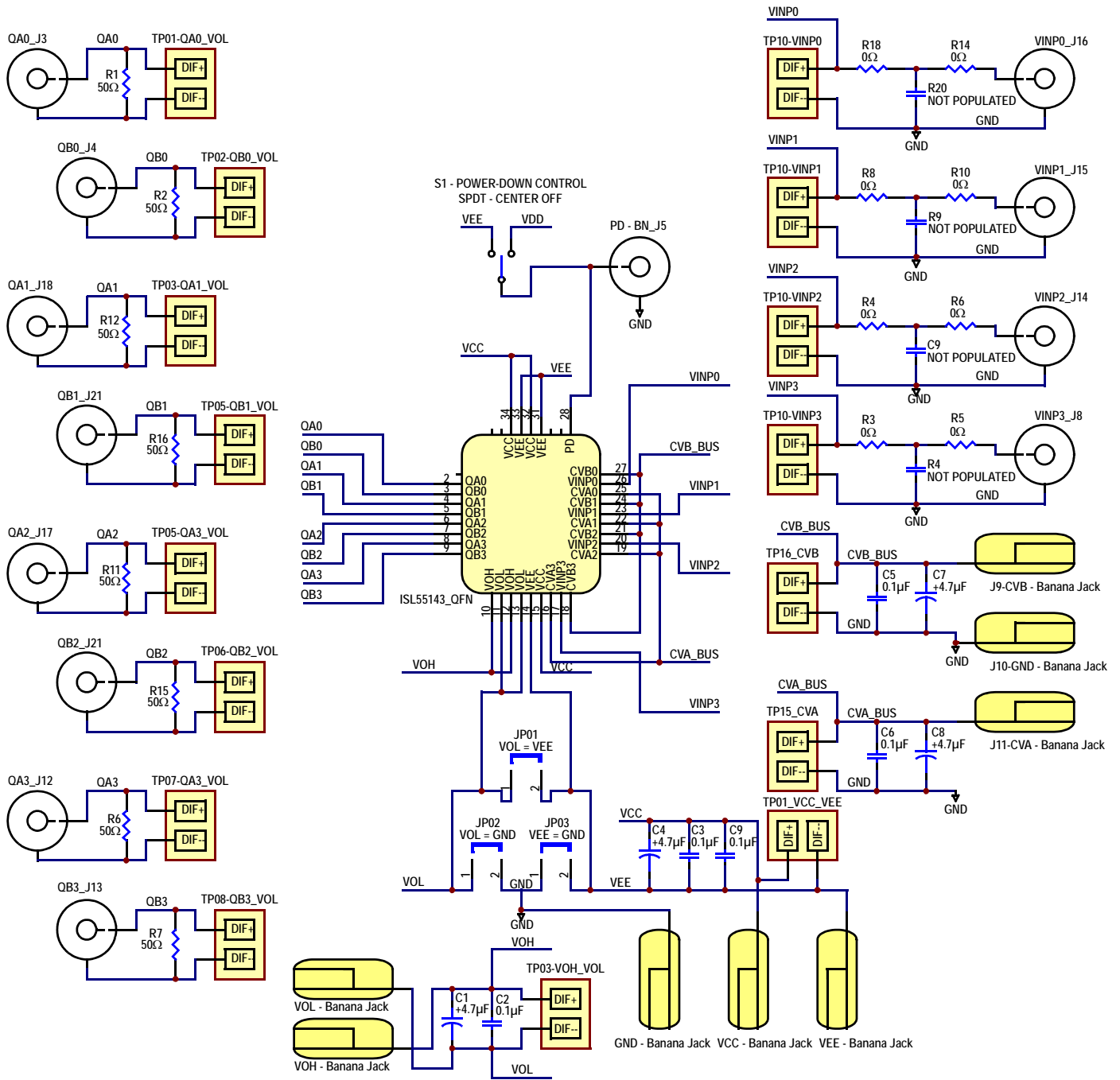

FIGURE 10. ISL55143IRZ QFN QUAD COMPARATOR EVALUATION BOARD

Intersil Corporation reserves the right to make changes in circuit design, software and/or specifications at any time without notice. Accordingly, the reader is cautioned to verify that the Application Note or Technical Brief is current before proceeding.

For information regarding Intersil Corporation and its products, see [www.intersil.com](http://www.intersil.com)