

CIRCUIT FOR ELECTRON PEDOMETER - ERGOMETER**DESCRIPTION**

The chip is a silicon-gate CMOS LSIs for electron pedometer-ergometer with function watch and alarm. Its provides count and indication of steps, calories, kilometers during current day and night and summing up at changing 24 hours, steps , calories, kilometers with values stored previous (mode «TOTAL DATA »). Length of steps setting from 25 to 95 centimeters. Frequency of registered pulses from external sensor at counting steps is no more than 6Hz at duration of time between the end of previous and beginning of counted pulse no less than 100 ms. Counting steps to 999999.

FEATURES

- One-chip CMOS constructions
- Single 1.5V battery operation
- Imbed in chip element of quartz generator with operating frequency of 32768 Hz, capacity, resistor, and voltage doubler
- Built-in LCD driver for control of 7-digit LCD in the mode of two level multiplexing with the mode marks "STEPS", "km", "KCAL", "COEFF", "L STEP", "ALARM", "TODAY", "TOTAL", divided by colons and dots.
- Operation from one battery with the voltage of 1.5V, low consumption power;
- Availability of circuits of contacts bracing suppression on buttons inputs;
- Frequency of registered pulses from external sensor at counting steps is no more than 6Hz at duration of time between the end of previous and beginning of counted pulse no less than 100 ms;
- Conversion of quantity of steps into calories , kilometers

FUNCTIONS

- 5 functions for counting time and calendar with indication of hours, minutes, seconds, month, date ;
- Alarm clock;
- Count the quantity of steps by means of evaluation and counting pulses from external sensor ;
- count and indication of steps, calories, kilometers during current day and night (mode « DATA OF THE CURRENT DAY»);
- Conversion of made steps into calories with consideration of the user coefficient with consideration of height, weight and male/female identification;
- summation up at changing 24 hours, steps , calories, kilometers with values stored previous (mode «TOTAL DATA»).

ABSOLUTE MAXIMUM RATINGS (T_a = 25°C)

Characteristic	Symbol	Value	Unit
Supply Voltage	U _{CC1}	- 0.3 ~ + 2.0	V
Operating Temperature	T _{por}	- 0 ~ + 70	°C
Storage Temperature	T _{stg}	- 55 ~ + 125	°C

IZ7010

ELECTRICAL CHARACTERISTICS ($T_a = 25^\circ\text{C}$, $U_{CC1} = 1.5\text{V}$, $\text{GND} = 0\text{V}$; unless otherwise specified)

Characteristic	Symbol	Test Condition	Min	Typ	Max	Unit
Supply Voltage	U_{CC1}		1.2	1.5	1.8	V
Display Voltage	U_{CC2}		2.7	3.0	3.3	V
Dynamic consumption current	I_{CC0}	Without Load, WAIT mode			2.5	μA
Input current of low level on inputs S1, S2, S3, S4	I_{IL}	$U_{CC1} = 1.8\text{V}$, $U_{IL} = 0.3\text{V}$			6	μA
Oscillator Start Voltage	U_{OSC}	Within 5 Sec			1.45	V
Oscillator Stop Voltage	U_{OSP}				1.2	V
Oscillator Frequency	F_{OSC}			32,768		Hz
Output Current (BD)	I_{OH}	$U_{OH} = 0.7\text{V}$, $U_{CC1} = 1.2\text{V}$, $U_{CC2} = 2.1\text{V}$	-200			μA
	I_{OL}	$U_{OL} = 0.5\text{V}$, $U_{CC1} = 1.2\text{V}$, $U_{CC2} = 2.1\text{V}$	200			μA
Alarm Output Frequency	F_{OUT}			4096		Hz

APPLICATION CIRCUIT

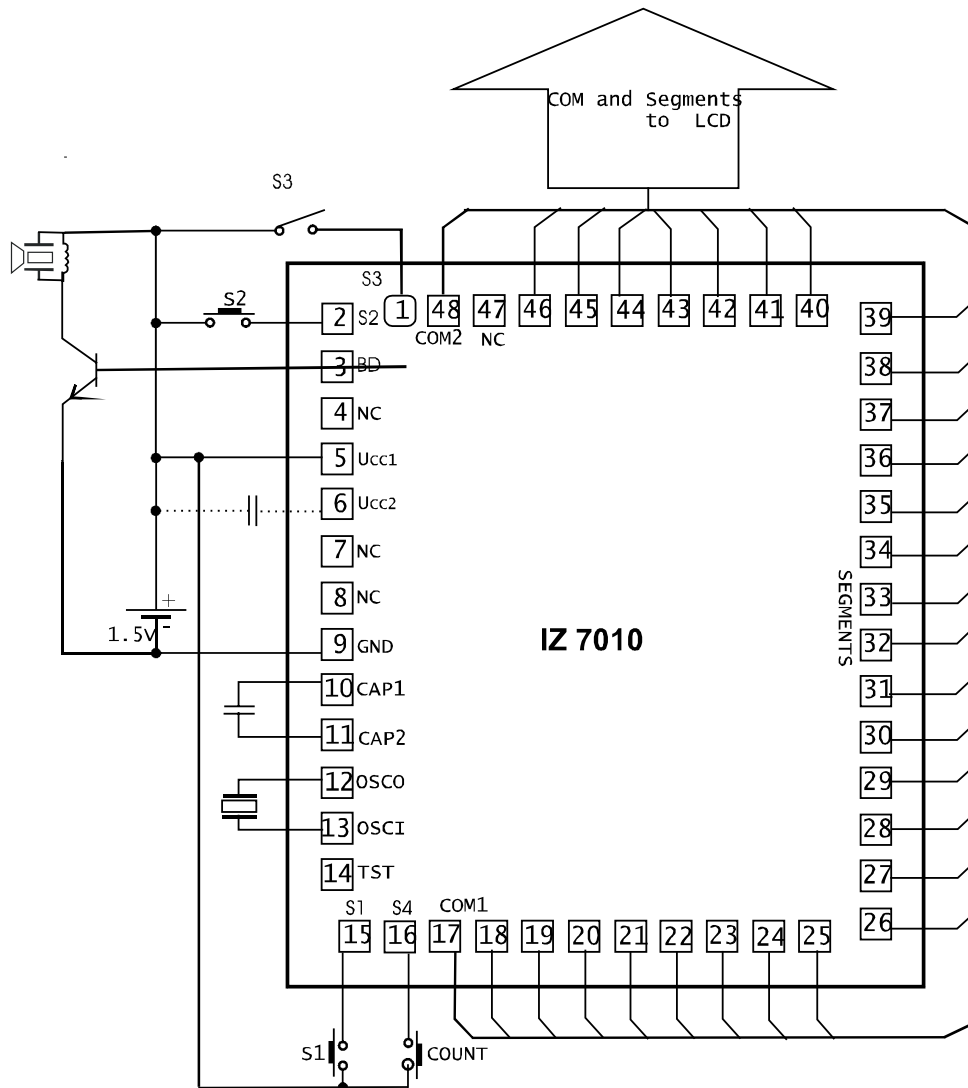

IZ7010

2	S2	①	48	47	46	45	44	43	42	41	40	39
			COM2	NC								
3	BD											38
4	NC											37
5	Ucc1											36
6												35
7	NC											34
8	NC											33
9	GND											32
10	CAP1											31
11	CAP2											30
12	OSCO											29
13	OSCI											28
14	TST											27
	S1	S4	COM1									26
15	16	17	18	19	20	21	22	23	24	25		

IZ 7010

SEGMENTS

Quartz resonator characteristics

Fp = 32768Hz
CL = 10pF
C₁ = 0.004pF
C₀ = 2.5pF
Rs = 35kOhm
Q = 35000

Description of contact pads

№ pad	Symbol	Description	№ pad	Symbol	Description
01	S3	control input	25	SEG8	LCD sign electrode control output
02	S2	control input	26	SEG9	LCD sign electrode control output
03	BD	Sound converter control outlet	27	SEG10	LCD sign electrode control output
04	NC	is not used	28	SEG11	LCD sign electrode control output
05	U _{CC1}	Output of primary supply voltage from voltage source	29	SEG12	LCD sign electrode control output
06	U _{CC2}	pin of secondary supply voltage	30	SEG13	LCD sign electrode control output
07	NC	is not used	31	SEG14	LCD sign electrode control output
08	NC	is not used	32	SEG15	LCD sign electrode control output
09	GND	general output	33	SEG16	LCD sign electrode control output
10	CAP1	output of connecting of voltage converter capacity	34	SEG17	LCD sign electrode control output
11	CAP2	output of connecting of voltage converter capacity	35	SEG18	LCD sign electrode control output
12	OSCO	output for connection of quartz resonator	36	SEG19	LCD sign electrode control output
13	OSCI	input for connection of quartz resonator	37	SEG20	LCD sign electrode control output
14	TST	is not used	38	SEG21	LCD sign electrode control output
15	S1	control input	39	SEG22	LCD sign electrode control output
16	S4	count input (COUNT)	40	SEG23	LCD sign electrode control output
17	COM1	LCD general electrode control output	41	SEG24	LCD sign electrode control output
18	SEG1	LCD sign electrode control output	42	SEG25	LCD sign electrode control output
19	SEG2	LCD sign electrode control output	43	SEG26	LCD sign electrode control output
20	SEG3	LCD sign electrode control output	44	SEG27	LCD sign electrode control output
21	SEG4	LCD sign electrode control output	45	SEG28	LCD sign electrode control output
22	SEG5	LCD sign electrode control output	46	SEG29	LCD sign electrode control output
23	SEG6	LCD sign electrode control output	47	NC	is not used
24	SEG7	LCD sign electrode control output	48	COM2	LCD General electrode control Output

Abbreviations

LCD - liquid crystal display

LCD FORMAT

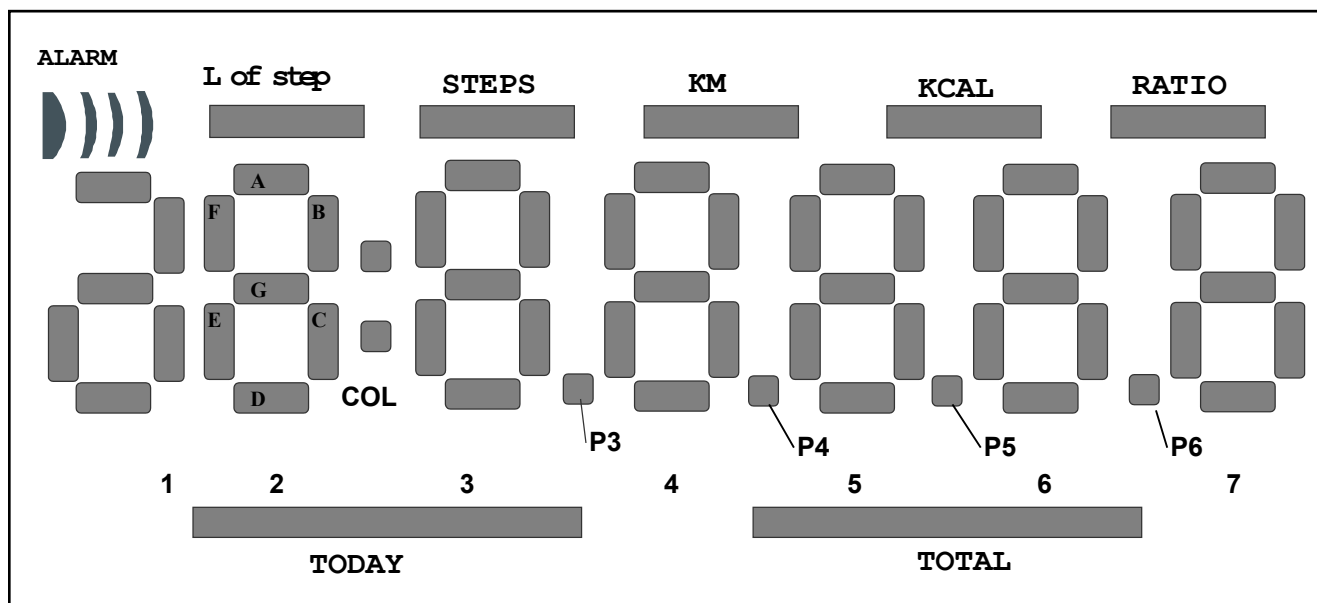

LCD segments State

Segment	COM1	COM2	Segment	COM1	COM2
SEG29	RATIO	A7	SEG14	F3	E3
SEG28	B7	G7	SEG13	B2	C2
SEG27	C7	D7	SEG12	COL	D2
SEG26	F7	E7	SEG11	C1	E2
SEG25	B6	G6	SEG10	B1	ADEG1
SEG24	C6	D6	SEG9	L of step	ALARM
SEG23	P6	TOTAL	SEG8	STEPS	F2
SEG22	E6	P5	SEG7	A2	G2
SEG21	D5	C5	SEG6	A3	G3
SEG20	F5	E5	SEG5	KM	B3
SEG19	B4	C4	SEG4	A4	G4
SEG18	P4	D4	SEG3	A5	G5
SEG17	F4	E4	SEG2	KCAL	B5
SEG16	C3	D3	SEG1	A6	F6
SEG15	P3	TODAY			

Control algorithm

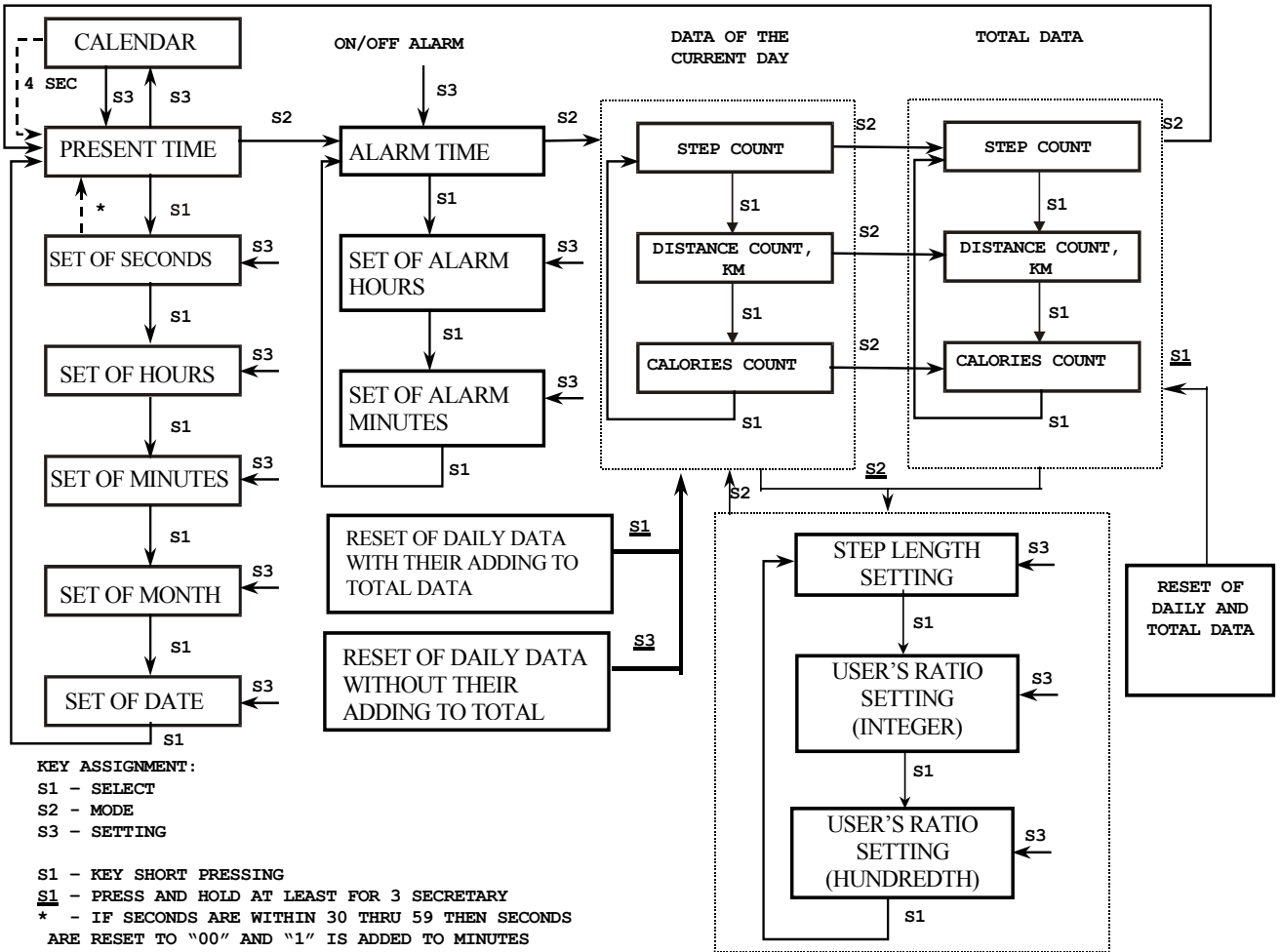

BASIC MODE

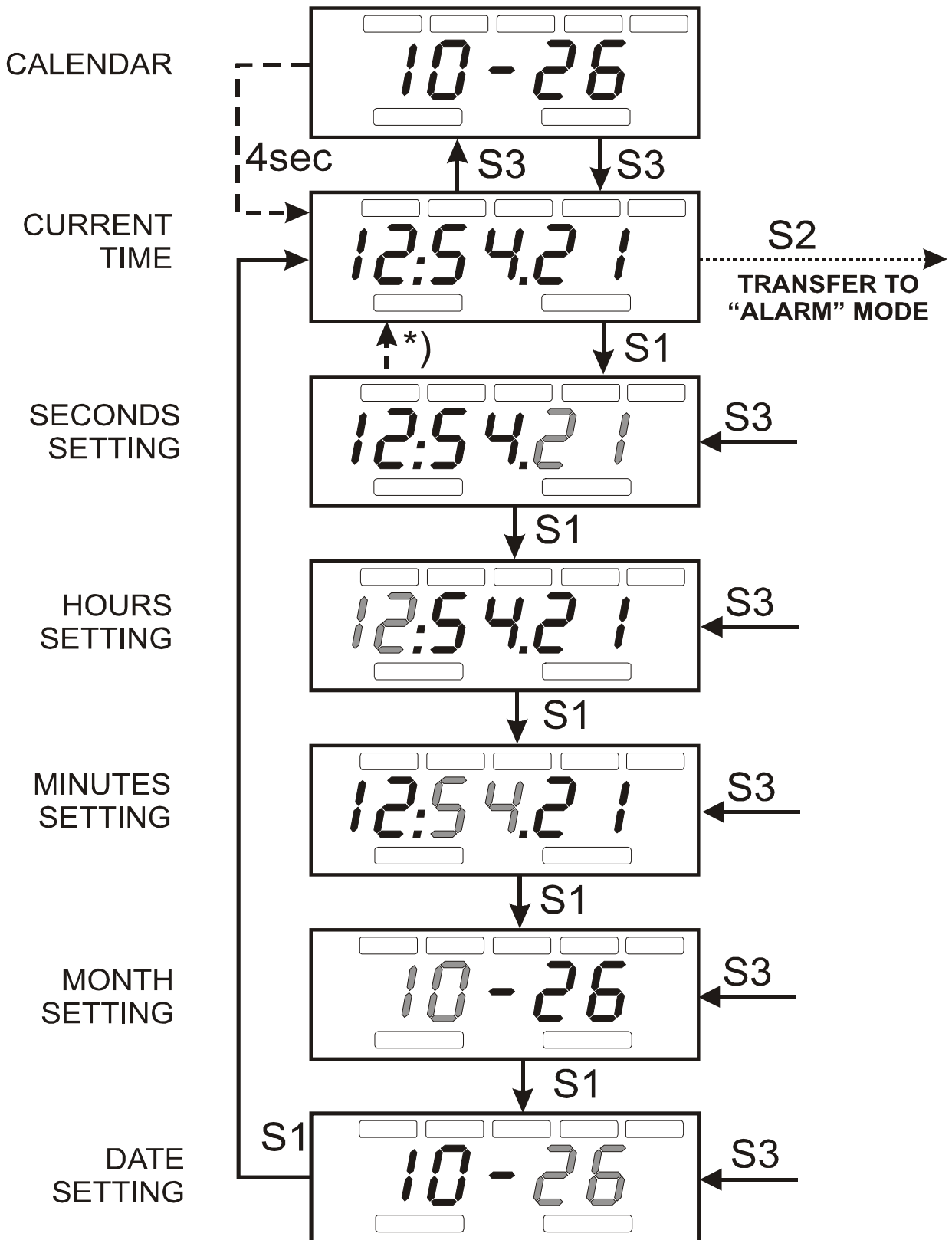

ALARM MODE

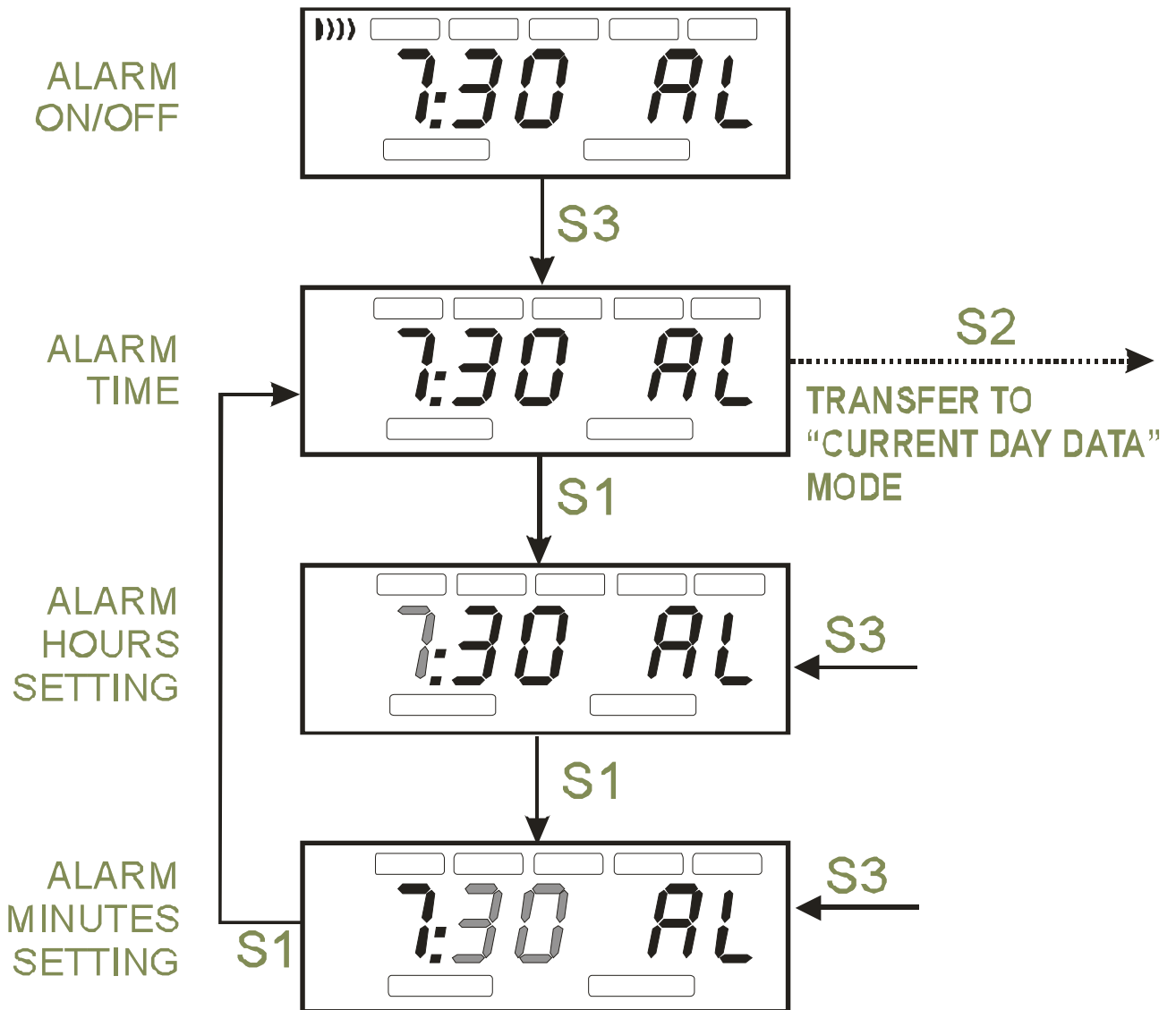

DATA OF THE CURRENT DAY

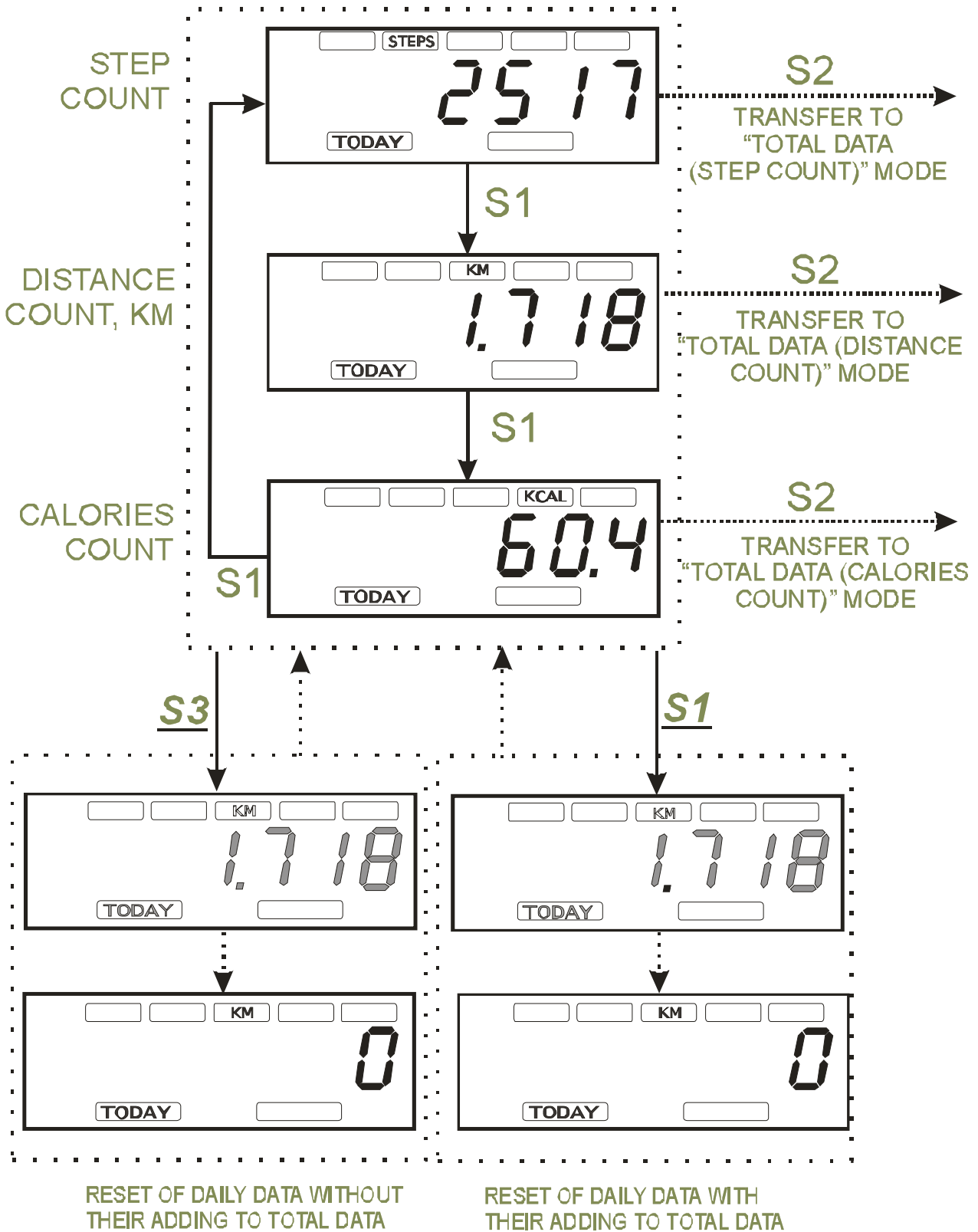

TOTAL DATA

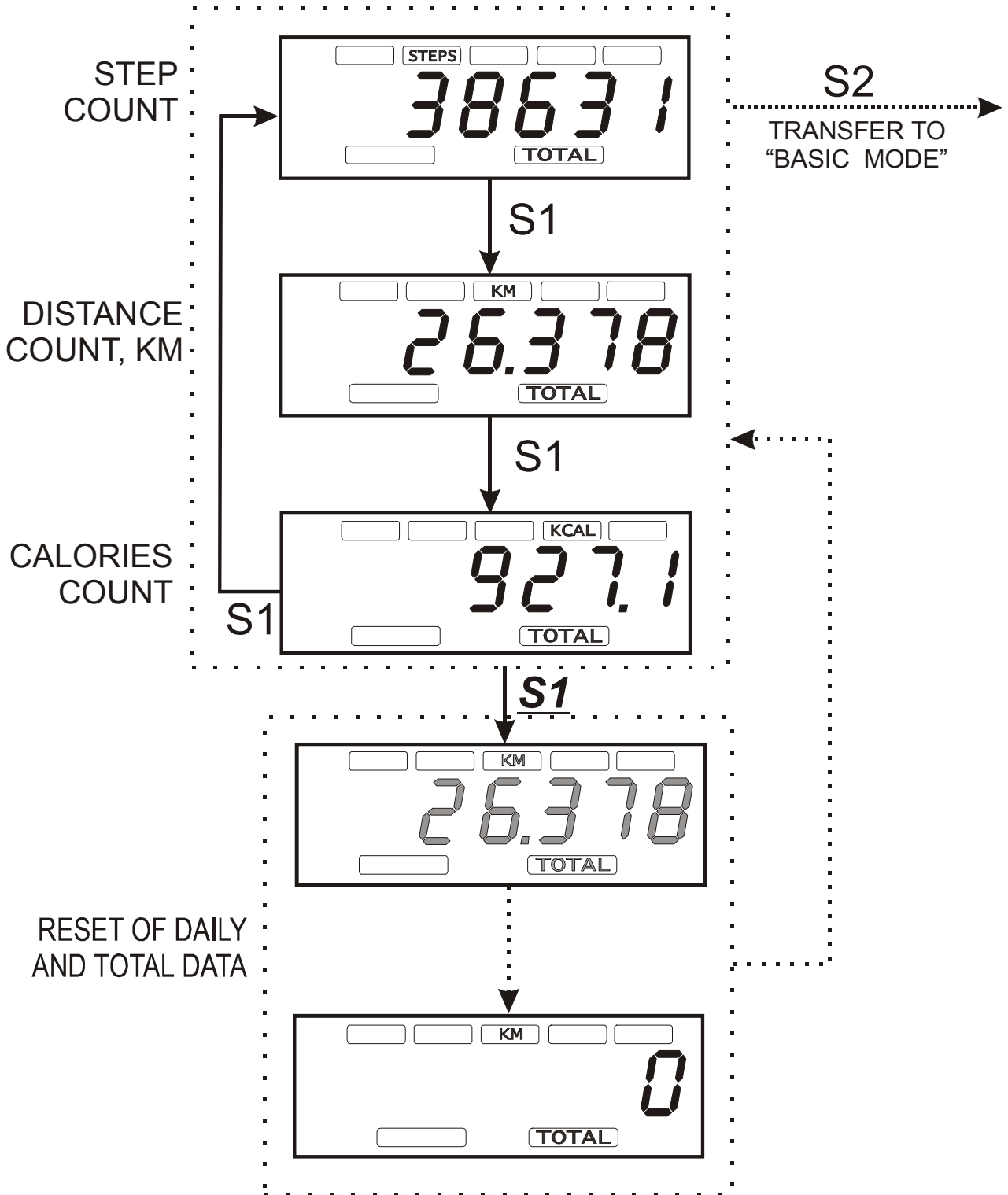

USER'S SETTING

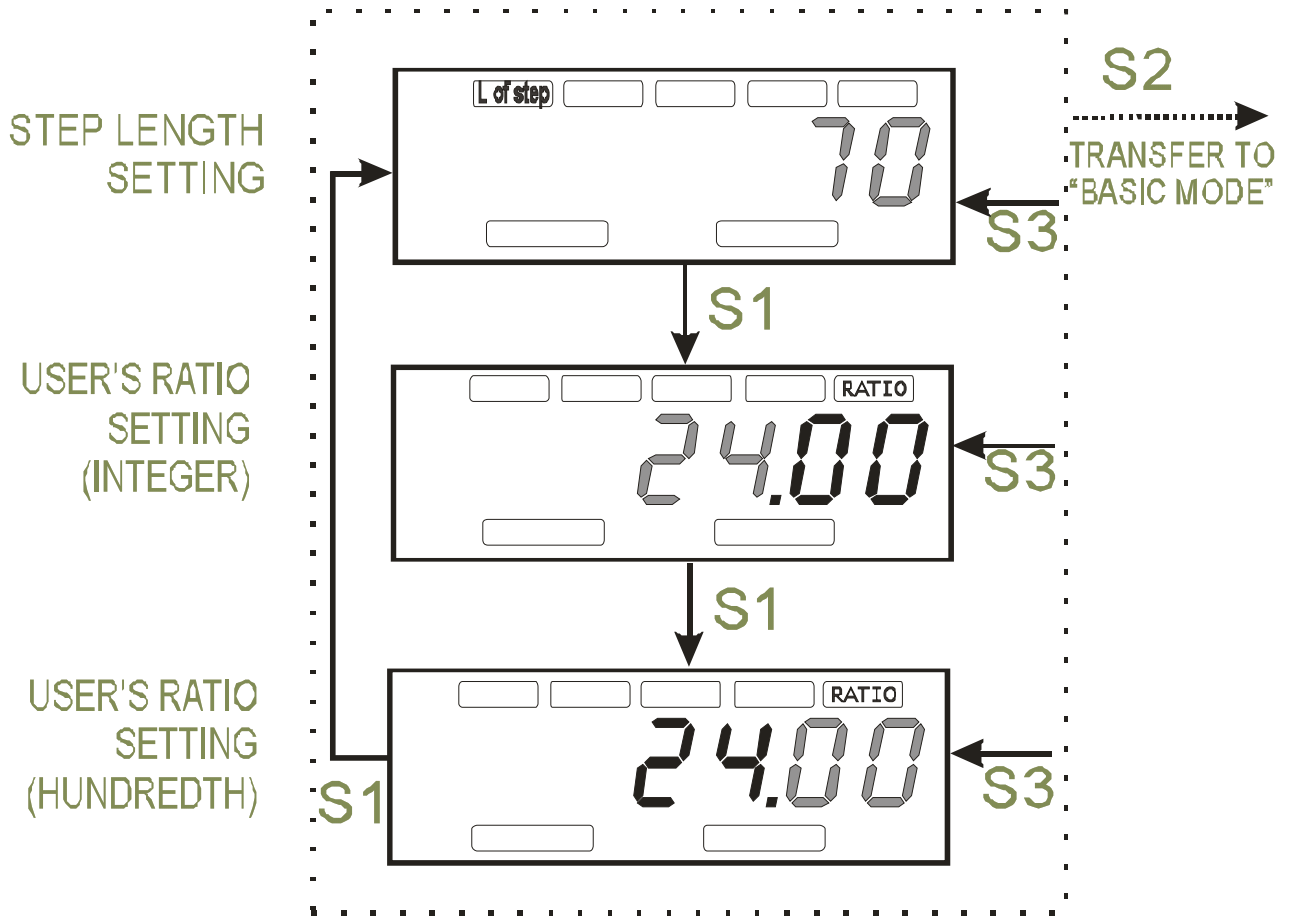

Calories Count Algorithm

Count of calories, consumed in walk, is performed by 5 steps by means of multiplication of the user coefficient by the movement rate coefficient.

$$CAL = RATIO * C RATE ;$$

where : RATIO – user coefficient – number of calories, consumed per 1 step with the movement rate of 60 steps per minute. It is entered by the user in the entry mode of the user settings. Range of values is from 5.00 to 25.00;

C RATE – coefficient of movement rate. It is calculated automatically during walk depending on the movement rate by each 5 steps in compliance with the table:

Table .1

Movement rate, steps/min	00-65	66-75	76-85	86-95	96-105	106-115	116-125	126-135	136-145	Over 145
C RATE – movement rate coefficient	5	8	11	15	19	23	28	32	36	38

For instance:

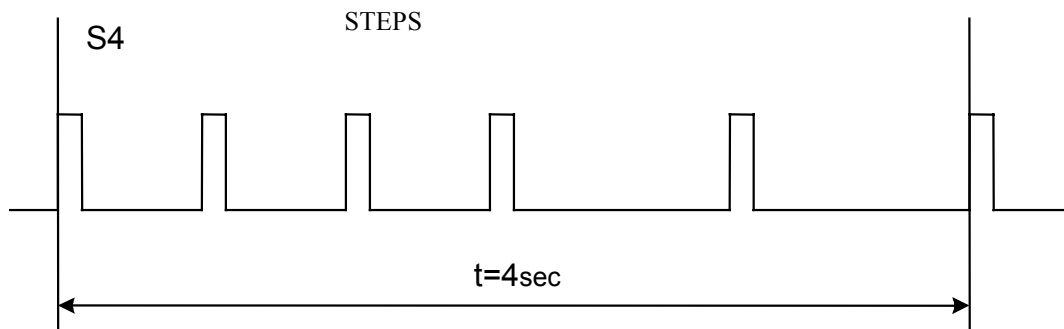

$$Rate = (5 \text{ steps} / 4 \text{ seconds}) * 60 \text{ seconds} = 75 \text{ steps per minute, C RATE} = 8;$$

User coefficient RATIO is selected in dependence on height, weight and male/female identification of human.

Tentative values of the user coefficient are listed in Table 1 for women and in Table 2 for men.

Tentative values of the user coefficient for women

Table 1

WEIGHT	HEIGHT					
	140	150	160	170	180	190
50	6,39	6,52	6,73	7,01	7,37	7,79
60	7,67	7,82	8,07	8,42	8,85	9,35
70	8,95	9,12	9,42	9,82	10,32	10,91
80	10,23	10,43	10,46	11,22	11,79	12,47
90	11,50	11,73	12,11	12,63	13,27	14,02
100	12,78	13,03	13,45	14,03	14,74	15,58
110	14,06	14,34	14,80	15,43	16,22	17,14
120	15,34	15,64	16,15	16,84	17,64	18,70

IZ7010

Tentative values of user coefficient for men

Table 2

WEIGHT	HEIGHT					
	150	160	170	180	190	200
50	7,86	7,94	8,11	8,36	8,68	9,07
60	9,43	9,52	9,73	10,03	10,42	10,8
70	11,00	11,11	11,35	11,70	12,15	12,69
80	12,57	12,70	12,97	13,37	13,89	14,51
90	14,14	14,28	14,59	15,04	15,62	16,32
100	15,71	15,87	16,21	16,71	17,36	18,14
110	17,28	17,46	17,83	18,39	19,09	19,95
120	18,85	19,05	19,46	20,06	20,83	21,76

For instance, for a woman with a weight of 63 kg and height of 174 cm the tentative value of the user coefficient $RATIO=8.42$ cal.

PAD LAYOUT

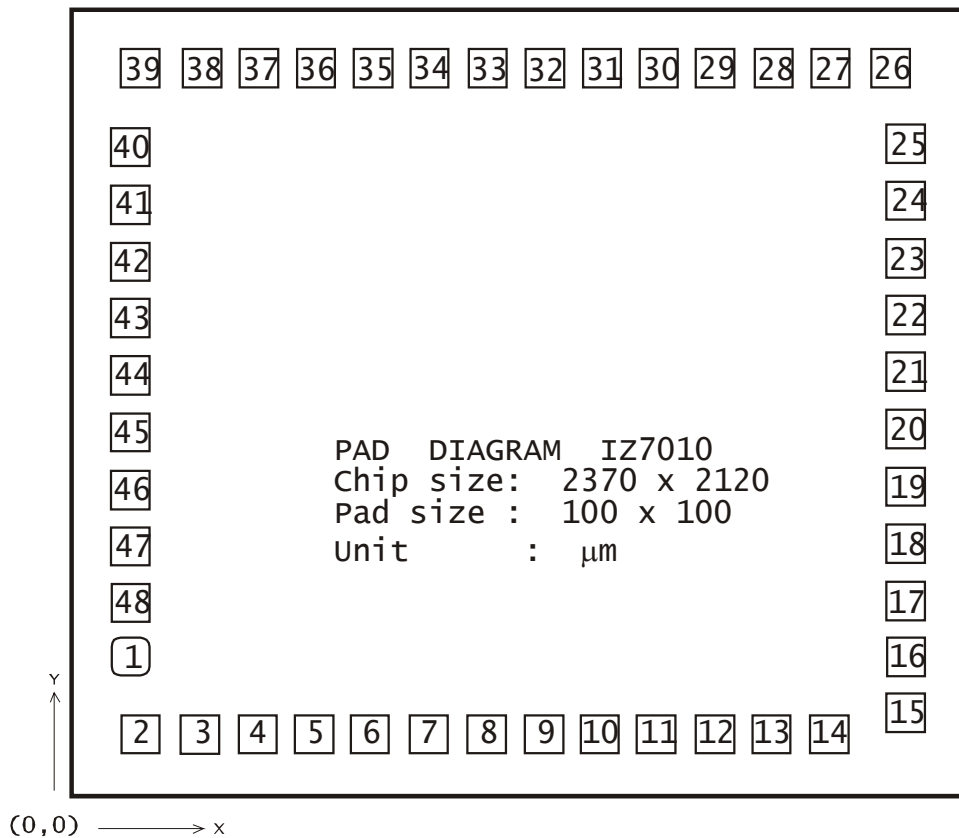

PAD LOCATION

Pad No.	Pad Name	X	Y	Pad No.	Pad Name	X	Y	Pad No.	Pad Name	X	Y
1	S3	106	335	17	COM1	2165	516	33	SEG16	1069	1911
2	S2	154	106	18	SEG1	2165	666	34	SEG17	919	1911
3	BD	305	106	19	SEG2	2165	817	35	SEG18	768	1911
4	NC	455	106	20	SEG3	2165	967	36	SEG19	618	1911
5	Ucc1	606	106	21	SEG4	2165	1118	37	SEG20	468	1911
6	Ucc2	756	106	22	SEG5	2165	1268	38	SEG21	317	1911
7	NC	906	106	23	SEG6	2165	1418	39	SEG22	155	1911
8	NC	1057	106	24	SEG7	2165	1569	40	SEG23	106	1676
9	GND	1207	106	25	SEG8	2165	1719	41	SEG24	106	1526
10	CAP1	1358	106	26	SEG9	2130	1911	42	SEG25	106	1375
11	CAP2	1508	106	27	SEG1 0	1972	1911	43	SEG26	106	1225
12	OSCO	1658	106	28	SEG1 1	1821	1911	44	SEG27	106	1074
13	OSCI	1809	106	29	SEG1 2	1671	1911	45	SEG28	106	924
14	TST	1959	106	30	SEG1 3	1520	1911	46	SEG29	106	774
15	S1	2165	215	31	SEG1 4	1370	1911	47	NC	106	624
16	S4	2165	366	32	SEG1 5	1220	1911	48	COM2	106	473