

Document Title

256Kx8 bit Super Low Power and Low Voltage Full CMOS Static RAM

Revision History

<u>Revision No.</u>	<u>History</u>	<u>Draft Date</u>	<u>Remark</u>
0.0	Initial draft	June 16 , 2003	Preliminary

The attached datasheets are provided by SAMSUNG Electronics. SAMSUNG Electronics CO., LTD. reserve the right to change the specifications and products. SAMSUNG Electronics will answer to your questions about device. If you have any questions, please contact the SAMSUNG branch offices.

K6F2008T2E Family

256Kx8 bit Super Low Power and Low Voltage Full CMOS Static RAM

FEATURES

- Process Technology: Full CMOS
- Organization: 256Kx8
- Power Supply Voltage: 2.7 ~ 3.6V
- Low Data Retention Voltage: 1.5V(Min)
- Three State Outputs
- Package Type: 32-TSOP1-0813.4F

GENERAL DESCRIPTION

The K6F2008T2E families are fabricated by SAMSUNG's advanced Full CMOS process technology. The families support industrial temperature ranges for user flexibility of system design. The families also supports low data retention voltage for battery back-up operation with low data retention current.

PRODUCT FAMILY

Product Family	Operating Temperature	Vcc Range	Speed(ns)	Power Dissipation		PKG Type
				Standby (I _{SB1} , Typ)	Operating (I _{CC1} , Max)	
K6F2008T2E-F	Industrial(-40~85°C)	2.7~3.6V	55 ¹⁾ /70ns	0.5μA ²⁾	3mA	32-TSOP1-0813.4F

1. The parameter is measured with 30pF test load.
2. Typical values are measured at V_{CC}=3.0V, T_A=25°C and not 100% tested.

PIN DESCRIPTION

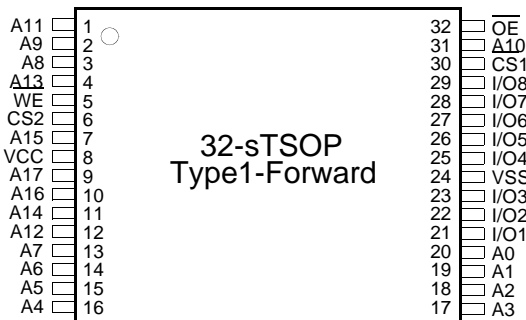

Name	Function	Name	Function
CS ₁ , CS ₂	Chip Select Input	I/O ₁ ~I/O ₈	Data Inputs/Outputs
OE	Output Enable	Vcc	Power
WE	Write Enable Input	Vss	Ground
A ₀ ~A ₁₇	Address Inputs	DNU	Do Not Use

FUNCTIONAL BLOCK DIAGRAM

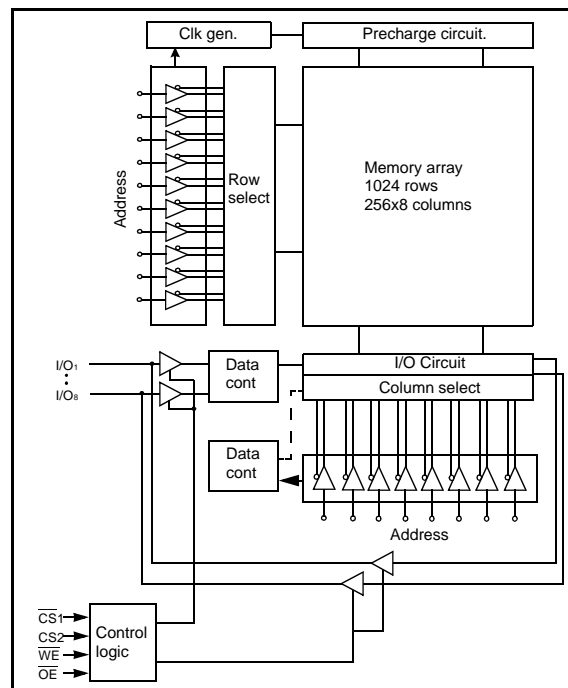

SAMSUNG ELECTRONICS CO., LTD. reserves the right to change products and specifications without notice.

PRODUCT LIST

Industrial Temperature Products(-40~85°C)	
Part Name	Function
K6F2008T2E-YF55 K6F2008T2E-YF70	32-sTSOP1-F, 55ns, 3.0V/3.3V, LL 32-sTSOP1-F, 70ns, 3.0V/3.3V, LL

FUNCTIONAL DESCRIPTION

CS ₁	CS ₂	OE	WE	I/O	Mode	Power
H	X ¹⁾	X ¹⁾	X ¹⁾	High-Z	Deselected	Standby
X ¹⁾	L	X ¹⁾	X ¹⁾	High-Z	Deselected	Standby
L	H	H	H	High-Z	Output Disable	Active
L	H	L	H	Dout	Read	Active
L	H	X ¹⁾	L	Din	Write	Active

1. X means don't care (Must be high or low states)

ABSOLUTE MAXIMUM RATINGS¹⁾

Item	Symbol	Ratings	Unit	Remark
Voltage on any pin relative to Vss	V _{IN} ,V _{OUT}	-0.2 to V _{CC} +0.5V	V	
Voltage on Vcc supply relative to Vss	V _{CC}	-0.2 to 4.6V	V	
Power Dissipation	P _D	1.0	W	
Storage temperature	T _{STG}	-65 to 150	°C	
Operating Temperature	T _A	-40 to 85	°C	K6F2008T2E-F

1. Stresses greater than those listed under "Absolute Maximum Ratings" may cause permanent damage to the device. Functional operation should be restricted to recommended operating condition. Exposure to absolute maximum rating conditions for extended periods may affect reliability.

RECOMMENDED DC OPERATING CONDITIONS¹⁾

Item	Symbol	Min	Typ.	Max	Unit
Supply voltage	V _{CC}	2.7	3.0/3.3	3.6	V
Ground	V _{SS}	0	0	0	V
Input high voltage	V _{IH}	2.2	-	V _{CC} +0.2 ²⁾	V
Input low voltage	V _{IL}	-0.2 ³⁾	-	0.6	V

Note:

1. Industrial Product: T_A=-40 to 85°C, unless otherwise specified.
2. Overshoot: V_{CC}+2.0V in case of pulse width≤20ns.
3. Undershoot: -2.0V in case of pulse width≤20ns.
4. Overshoot and undershoot are sampled, not 100% tested.

CAPACITANCE¹⁾ (f=1MHz, T_A=25°C)

Item	Symbol	Test Condition	Min	Max	Unit
Input capacitance	C _{IN}	V _{IN} =0V	-	8	pF
Input/Output capacitance	C _{IO}	V _{IO} =0V	-	10	pF

1. Capacitance is sampled, not 100% tested

DC AND OPERATING CHARACTERISTICS

Item	Symbol	Test Conditions	Min	Typ ¹⁾	Max	Unit
Input leakage current	I _{LI}	V _{IN} =V _{SS} to V _{CC}	-1	-	1	μA
Output leakage current	I _{LO}	$\overline{CS}_1=V_{IH}$ or $CS_2=V_{IL}$ or $\overline{OE}=V_{IH}$ or $\overline{WE}=V_{IL}$, V _{IO} =V _{SS} to V _{CC}	-1	-	1	μA
Average operating current	I _{CC1}	Cycle time=1μs, 100% duty, I _{IO} =0mA, $\overline{CS}_1 \leq 0.2V$, $CS_2 \geq V_{CC}-0.2V$, V _{IN} ≤0.2V or V _{IN} ≥V _{CC} -0.2V	-	-	3	mA
	I _{CC2}	Cycle time=Min, 100% duty, I _{IO} =0mA, $\overline{CS}_1=V_{IL}$, $CS_2=V_{IH}$, V _{IN} =V _{IL} or V _{IH}	-	-	35	mA
Output low voltage	V _{OL}	I _{OL} =2.1mA	-	-	0.4	V
Output high voltage	V _{OH}	I _{OH} =-1.0mA	2.4	-	-	V
Standby Current(CMOS)	I _{SB1}	Other inputs=V _{SS} to V _{CC} 1) $\overline{CS}_1 \geq V_{CC}-0.2V$, $CS_2 \geq V_{CC}-0.2V$ (\overline{CS}_1 controlled) or 2) $0V \leq CS_2 \leq 0.2V$ CS_2 controlled)	-	0.5	10	μA

1. Typical value are measured at V_{CC}=3.0V, T_A=25°C, and not 100% tested.

AC OPERATING CONDITIONS

TEST CONDITIONS (Test Load and Test Input/Output Reference)

Input pulse level: 0.4 to 2.2V
 Input rising and falling time: 5ns
 Input and output reference voltage: 1.5V
 Output load (See right): $C_L=100\text{pF}+1\text{TTL}$
 $C_L=30\text{pF}+1\text{TTL}$

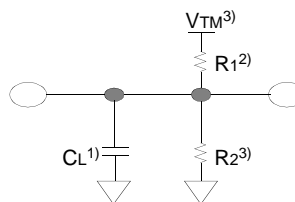

1. Including scope and jig capacitance
2. $R_1=3070\Omega$, $R_2=3150\Omega$
3. $V_{TM}=2.8\text{V}$

AC CHARACTERISTICS ($V_{CC}=2.7\sim 3.6\text{V}$, $T_A=-40$ to 85°C)

Parameter List		Symbol	Speed Bins				Units
			55ns ¹⁾		70ns		
			Min	Max	Min	Max	
Read	Read Cycle Time	t _{RC}	55	-	70	-	ns
	Address Access Time	t _{AA}	-	55	-	70	ns
	Chip Select to Output	t _{CO}	-	55	-	70	ns
	Output Enable to Valid Output	t _{OE}	-	25	-	35	ns
	Chip Select to Low-Z Output	t _{LZ}	10	-	10	-	ns
	Output Enable to Low-Z Output	t _{OLZ}	5	-	5	-	ns
	Chip Disable to High-Z Output	t _{HZ}	0	20	0	25	ns
	Output Disable to High-Z Output	t _{OHZ}	0	20	0	25	ns
	Output Hold from Address Change	t _{OH}	10	-	10	-	ns
Write	Write Cycle Time	t _{WC}	55	-	70	-	ns
	Chip Select to End of Write	t _{CW}	45	-	60	-	ns
	Address Set-up Time	t _{AS}	0	-	0	-	ns
	Address Valid to End of Write	t _{AW}	45	-	60	-	ns
	Write Pulse Width	t _{WP}	40	-	50	-	ns
	Write Recovery Time	t _{WR}	0	-	0	-	ns
	Write to Output High-Z	t _{WHZ}	0	20	0	20	ns
	Data to Write Time Overlap	t _{DW}	25	-	30	-	ns
	Data Hold from Write Time	t _{DH}	0	-	0	-	ns
	End Write to Output Low-Z	t _{OW}	5	-	5	-	ns

1. The parameter is measured with 30pF test load.

DATA RETENTION CHARACTERISTICS

Item	Symbol	Test Condition	Min	Typ	Max	Unit
V _{CC} for data retention	V _{DR}	$\overline{CS}_1 \geq V_{CC}-0.2\text{V}^{1)}$	1.5	-	3.6	V
Data retention current	I _{DR}	$V_{CC}=1.5\text{V}$, $\overline{CS}_1 \geq V_{CC}-0.2\text{V}^{1)}$	-	0.2 ²⁾	2	μA
Data retention set-up time	t _{SDR}	See data retention waveform	0	-	-	ns
Recovery time	t _{RDR}		t _{RC}	-	-	

1. $\overline{CS}_1 \geq V_{CC}-0.2\text{V}$, $CS_2 \geq V_{CC}-0.2\text{V}$ (\overline{CS}_1 controlled) or $CS_2 \leq 0.2\text{V}$ (CS_2 controlled).
 2. Typical values are measured at $T_A=25^\circ\text{C}$ and not 100% tested.

TIMING DIAGRAMS

TIMING WAVEFORM OF READ CYCLE(1) (Address Controlled, $\overline{CS1}=\overline{OE}=V_{IL}$, $\overline{WE}=V_{IH}$)

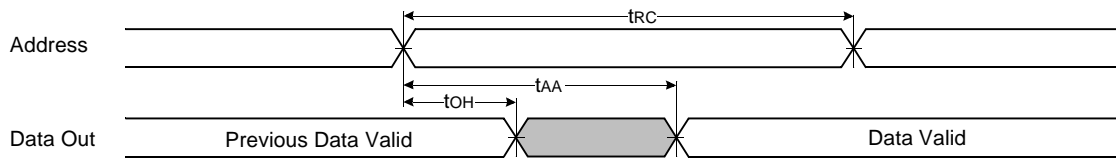

TIMING WAVEFORM OF READ CYCLE(2) ($\overline{WE}=V_{IH}$)

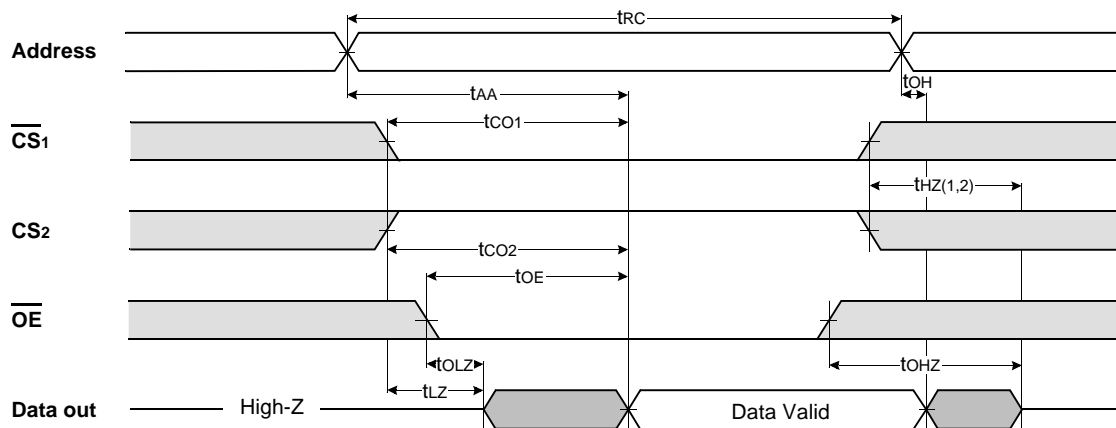

NOTES (READ CYCLE)

1. t_{HZ} and t_{OHZ} are defined as the time at which the outputs achieve the open circuit conditions and are not referenced to output voltage levels.
2. At any given temperature and voltage condition, $t_{HZ}(\text{Max.})$ is less than $t_{LZ}(\text{Min.})$ both for a given device and from device to device interconnection.

TIMING WAVEFORM OF WRITE CYCLE(1) (\overline{WE} Controlled)

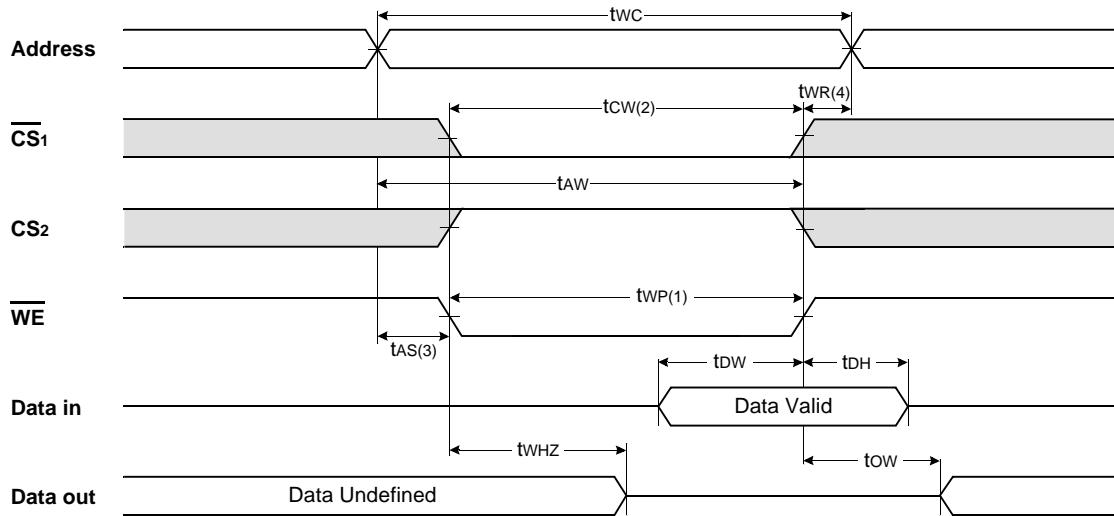

TIMING WAVEFORM OF WRITE CYCLE(2) ($\overline{CS1}$ Controlled)

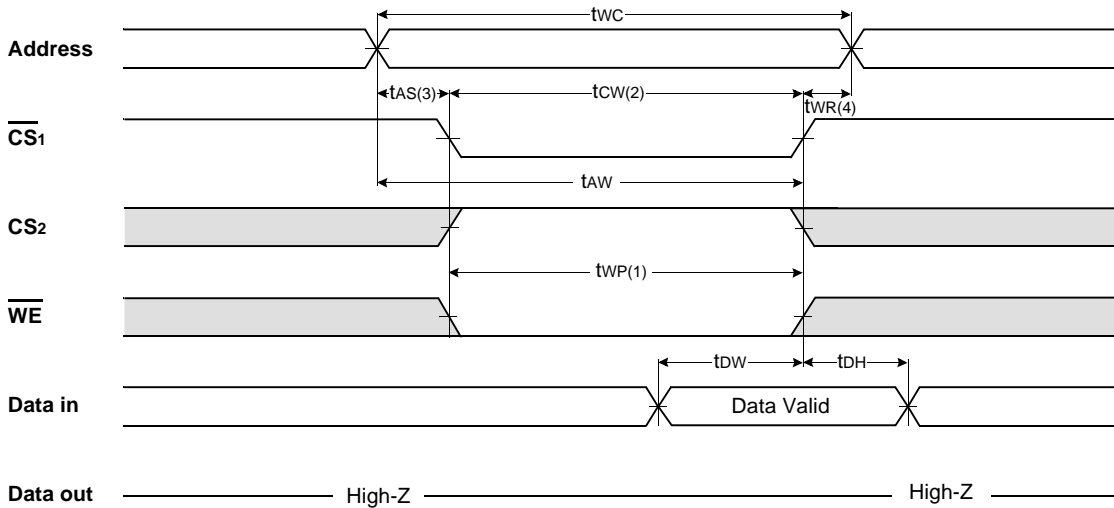

K6F2008T2E Family

TIMING WAVEFORM OF WRITE CYCLE(3) (CS₂ Controlled)

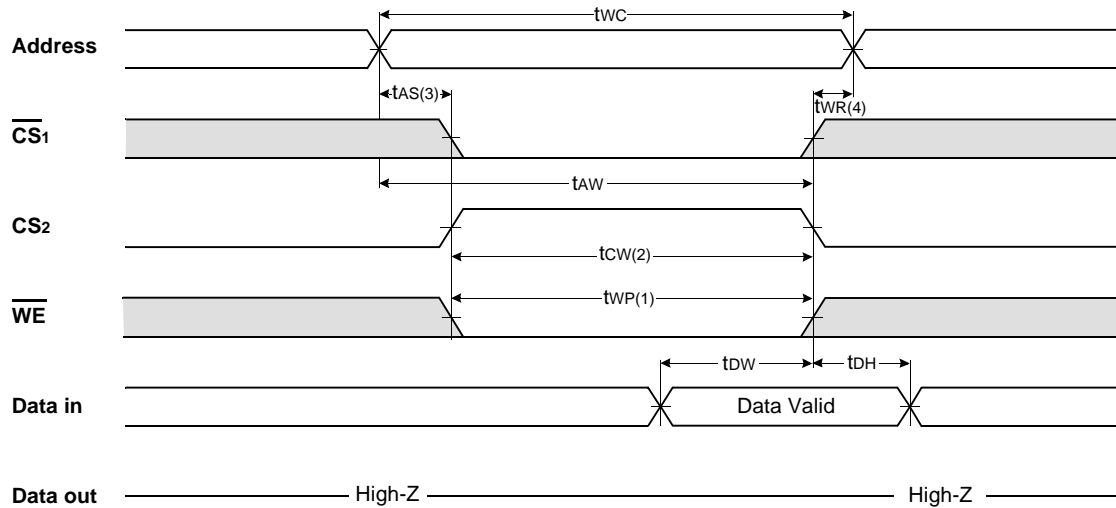

NOTES (WRITE CYCLE)

1. A write occurs during the overlap of a low \overline{CS}_1 , a high CS_2 and a low \overline{WE} . A write begins at the latest transition among \overline{CS}_1 goes low, CS_2 going high and \overline{WE} going low : A write end at the earliest transition among CS_1 going high, CS_2 going low and \overline{WE} going high, t_{WP} is measured from the beginning of write to the end of write.
2. t_{CW} is measured from the \overline{CS}_1 going low or CS_2 going high to the end of write.
3. t_{AS} is measured from the address valid to the beginning of write.
4. t_{WR} is measured from the end of write to the address change.

DATA RETENTION WAVE FORM

CS₁ controlled

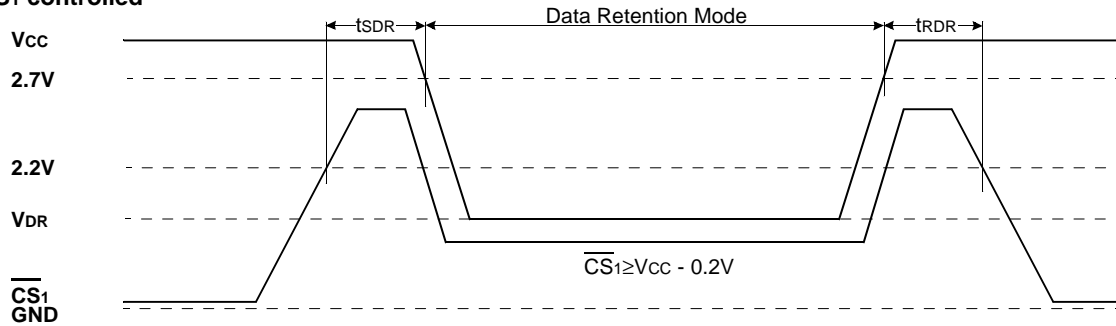

CS₂ controlled

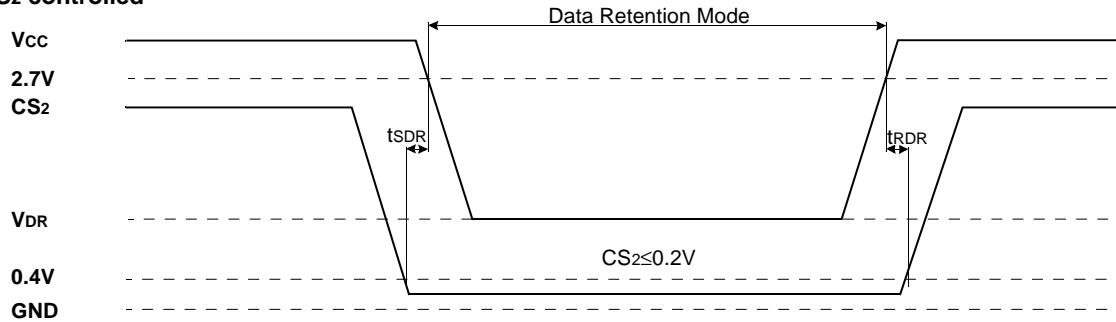

PACKAGE DIMENSIONS

Units: millimeters(inches)

32 PIN THIN SMALL OUTLINE PACKAGE TYPE I (0813.4F)

